

AS1357

Programmable Triple LDO

Data Sheet

1 General Description

The AS1357 is a high-performance triple CMOS low-dropout voltage regulator in a single QFN package. The efficient set of programmable power supplies is optimized to deliver the best compromise between quiescent current and regulator performance for mobile phones, PDAs, MP3 players, and other battery powered devices.

The one-time-programmable (OTP) function provides greater design flexibility by allowing for independent programming of the output voltage for each regulator on-site. The OTP function allows for fast prototyping reducing development times and costs significant. Factory trimmed versions for full-production are also available.

Stability is guaranteed with ceramic output capacitors of only 1 μ F ($\pm 20\%$ – X5R) up to 4.7 μ F ($\pm 20\%$ – X5R). The low equivalent series resistance (ESR) of these capacitors ensures low output impedance at high frequencies.

Regulation performance is excellent even under low dropout conditions, when the power transistor has to operate in linear mode.

The low-noise performance allows direct connection of noise sensitive circuits without additional filtering networks.

The AS1357 is available in a 12-pin QFN 4x4 or 16-pin QFN 3x3 package.

2 Key Features

- 3 Independent Voltage Regulators with Shutdown
- Output Current: 200mA each LDO
- One Time Programmable Output Voltage (User- or Factory-Trimmed)
- Programmable Output Voltage Range: 1.8 to 3.3V in 0.1V Steps
- Accuracy: $\pm 1.5\%$
- PSRR: 70dB at 1kHz, 40dB at 100kHz
- Line Regulation: $\pm 2\text{mV}$
- Load Regulation: $\pm 0.6\text{mV}$
- Supply Range: 3 to 5.5V
- 0.2V Dropout Voltage @ I = 200mA
- Shutdown Current: $\leq 1\mu\text{A}$
- Supply Current Without Load: 175 μA (typ)
- Softstart for Low Inrush Current
- Stable with low ESR Ceramic Capacitors from 1 to 4.7 μF
- Low Noise: 40 μV rms @10Hz to 100kHz Bandwidth
- Thermal Protection
- Over-Current Protection
- Temperature Range: -40 to +85°C
- Package Types: 12-pin QFN 4x4 and 16-pin QFN 3x3

3 Applications

The AS1357 is ideal for cordless and mobile phones, MP3 players, CD and DVD players, PDAs, handheld computers, digital cameras, and any other hand-held battery-powered device.

Figure 1. Pinout Assignments (Top View)

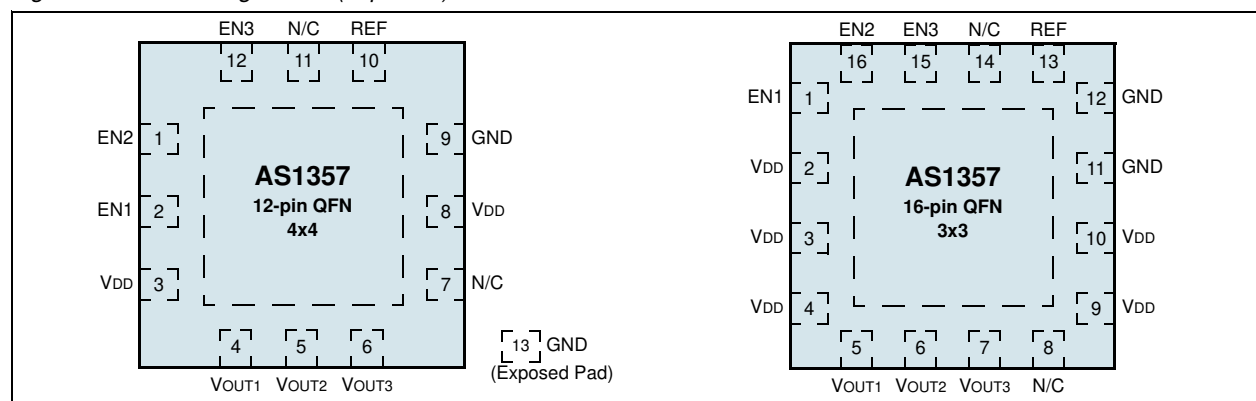

4 Pinout

Pin Assignments

Figure 2. Pin Assignments (Top View – Not To Scale)

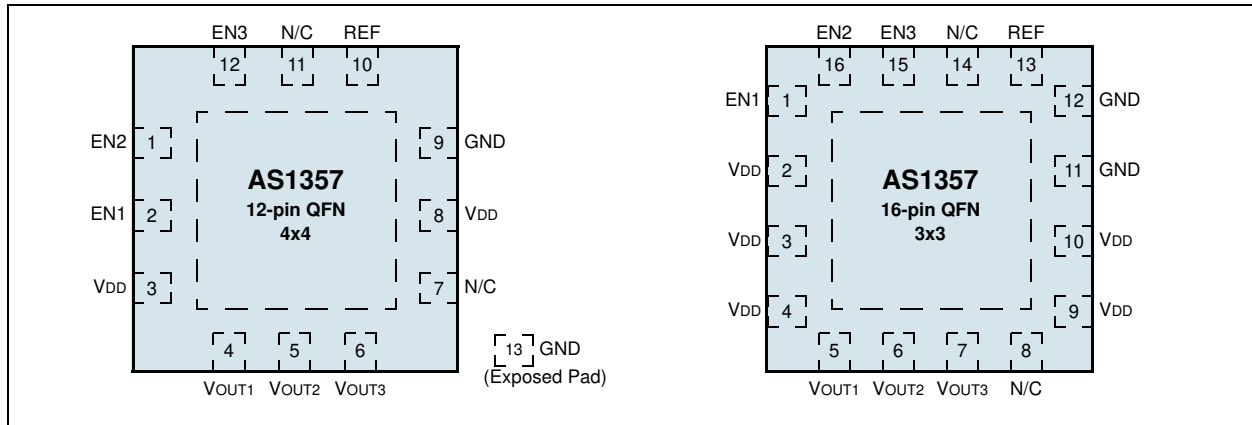

Pin Descriptions

Table 1. Pin Descriptions

12-pin QFN 4x4 Pin Number	16-pin QFN 3x3 Pin Number	Pin Name	Description
2	1	EN1	VOUT1 Digital Input Enable
1	16	EN2	VOUT2 Digital Input Enable
12	15	EN3	VOUT3 Digital Input Enable
9	11, 12	GND	Negative Supply Voltage. Note: All GND pins must be connected together externally.
13	-	GND	Negative Supply Voltage. This pin is the exposed pad. Note: All GND pins must be connected together externally.
10	13	REF	Analog Reference Voltage. Note: Connect to 100nF capacitor during normal operation.
3, 8	2, 3, 4, 9, 10	VDD	Positive Supply Voltage. Note: All VDD pins must be connected together externally.
4	5	VOUT1	Regulated Analog Output Voltage 1
5	6	VOUT2	Regulated Analog Output Voltage 2
6	7	VOUT3	Regulated Analog Output Voltage 3
7, 11	8, 14	N/C	Not connected.

5 Absolute Maximum Ratings

Stresses beyond those listed in Table 3 may cause permanent damage to the device. These are stress ratings only, and functional operation of the device at these or any other conditions beyond those indicated in the operational sections of the specifications is not implied. Exposure to absolute maximum rating conditions for extended periods may affect device reliability.

Table 2. Absolute Maximum Ratings

Parameter	Min	Max	Units	Comments
V _{DD} to GND	-0.3	7	V	
Any other pin to GND	-0.3	V _{DD} + 0.3	V	
Continuous Power Dissipation QFN12 4x4mm	1100	2800	mW	Min value measured at T _{AMB} = 85°C; max value measured at T _{AMB} = 25°C.
Package-Body Peak Temperature		260	°C	The reflow peak soldering temperature (body temperature) specified is in accordance with <i>IPC/JEDEC J-STD-020C "Moisture/Reflow Sensitivity Classification for non-hermetic Solid State Surface Mount Devices"</i> .
Operating Temperature	-40	85	°C	
Storage Temperature	-65	150	°C	
Electrostatic Discharge Protection (ESD) Level	1		kV	HBM – Norm: <i>MIL 883 E method 3015</i> .

6 Electrical Characteristics

$V_{DD} = 4V$; $T_{AMB} = -40$ to $+85^{\circ}C$ (Typ values are for $T_{AMB} = 25^{\circ}C$); $C_{LOAD} = 1\mu F$ (Ceramic); unless otherwise specified.

Table 3. Electrical Characteristics

Symbol	Parameter	Conditions	Min	Typ	Max	Unit
V _{DD}	Supply Voltage Range		3		5.5	V
V _{OUT}	Output Voltage Range		1.8		3.3	V
R _{ON}	On Resistance				1	Ω
PSRR ¹	Power Supply Rejection Ratio	f = 1kHz, C _{REF} = 100nF	70			dB
		f = 100kHz, C _{REF} = 100nF	40			
I _{OFF}	Shut Down Current	EN _x = Low			1	μA
I _{VDD}	Supply Current	Without Load		175	275	μA
t _{set} ¹	Output Voltage Settling Time	I _{LOAD} Switched from 0 to 100mA			50	μs
t _{start} ¹	Start-up Time ²	C _{REF} = 100nF Pre-charged			300	μs
		C _{REF} = 0nF Uncharged		300		μs
		C _{REF} = 100nF Uncharged		15		ms
V _{OUT}	Output Voltage Tolerance	I _{LOAD} = 0mA, T _{AMB} = 25°C	-1.5		1.5	%
		I _{LOAD} = 0 to 200mA	-2		2	%
V _{LINE} REG	Line Regulation, Static	V _{DD} = 5.5V	-1		1	%
		V _{DD} = 3 to 4.5V	-2		2	mV ¹
V _{LOAD} REG	Load Regulation, Static	I _{LOAD} = 0 to 50 mA		0.3	2.5	mV ¹
		I _{LOAD} = 0 to 200 mA (referenced to 100mA)		0.6	5	mV ¹
V _{IH}	Enable Input Voltage High		0.6 x V _{DD}			V
V _{IL}	Enable Input Voltage Low				0.8	V
I _{LOAD}	Output Current		0		200	mA
I _{LIMIT}	Output Current Limitation			400		mA
V _{Noise}	Output Noise Voltage	10 to 100kHz, C _{REF} = 100nF		40		μV _{RMS}
	Thermal Protection			145		°C

Notes:

1. Guaranteed by design and verified by lab evaluation.
2. Startup is performed if any EN pin goes high.

7 Typical Application

Figure 3. Typical AS1357_uxy Application

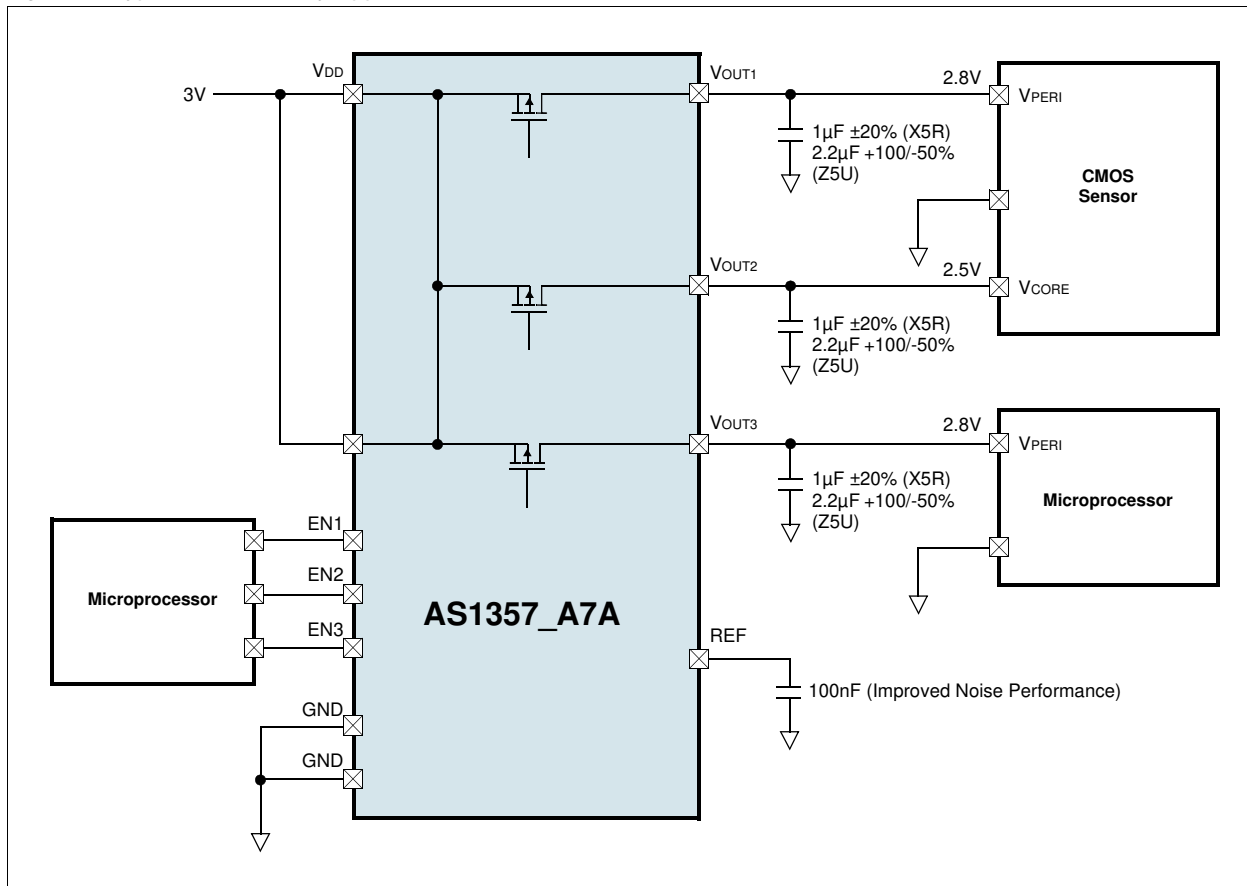

One-Time Programming Procedure Output Voltages

The three LDOs can be programmed and burned to any output voltage between 1.8 and 3.3V in steps of 0.1V. Customers can burn the desired output voltages onsite using the austriamicrosystems programming board.

Furthermore, the AS1357 is available in pre-programmed versions with fixed output voltages (see Ordering Information on page 9.)

Figure 4. AS1357 Block Diagram

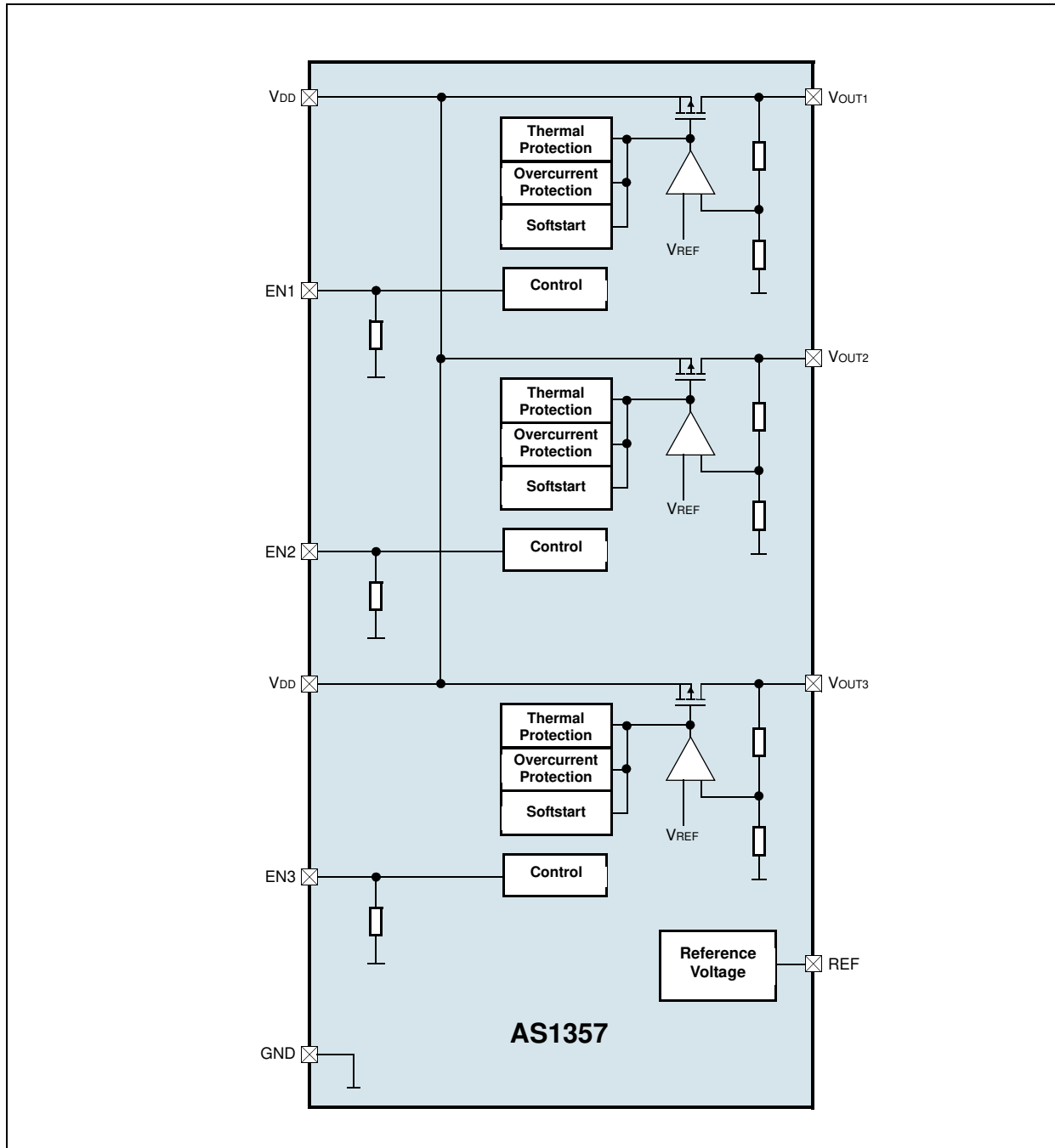

8 Package Drawings and Markings

The AS1357 is available in a 12-pin QFN 4x4 package and a 16-pin QFN 3x3 package.

Figure 5. 12-pin QFN 4x4 and 16-pin QFN 3x3 Packages

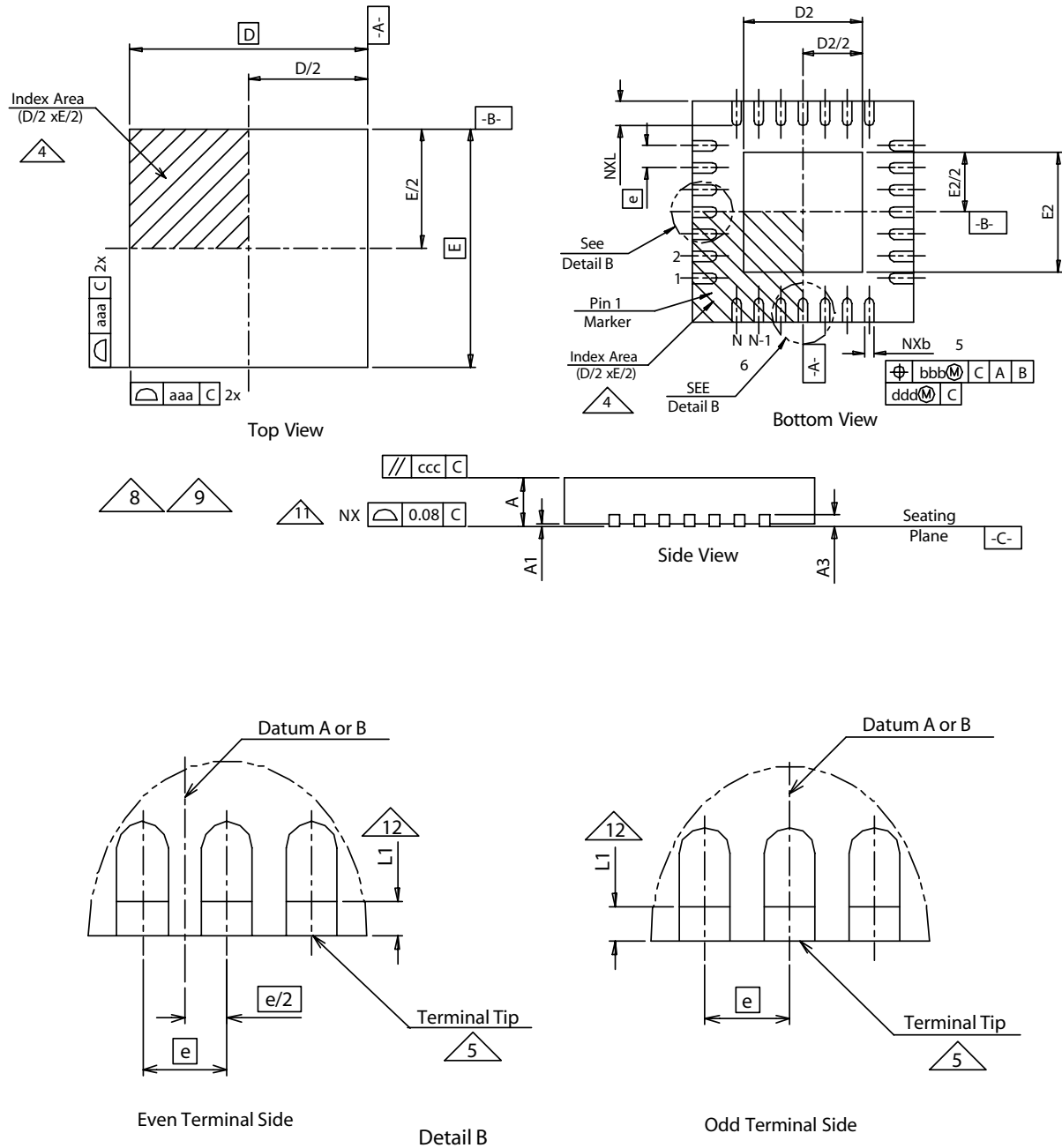

Notes:

1. Dimensioning and tolerancing conform to ASME Y14.5M-1994.
2. All dimensions are in millimeters; angles in degrees.

3. N is the total number of terminals.
4. The terminal #1 identifier and terminal numbering convention shall conform to *JEDEC 95 SPP-012*. Details of terminal #1 identifier are optional but must be located within the zone indicated. The terminal #1 identifier may be either a mold or marked feature.
5. Dimension b applies to metallized terminal and is measured between 0.15 and 0.30mm from terminal tip. If one end of the terminal has the optional radius, the b dimension should not be measured in that radius area.
6. Dimensions ND and NE refer to the number of terminals on each D and E side, respectively.
7. Depopulation is possible in a symmetrical fashion.
8. [Figure 5](#) is shown for illustration only and does not represent any specific variation.
9. All variations may be constructed per [Figure 5](#), however variations may alternately be constructed between square or rectangle shape per dimensions D and E.
10. Refer to the Dimensions Table for a complete set of dimensions.
11. Bilateral coplanarity zone applies to the exposed heat sink slug as well as the terminals.
12. Depending on the method of lead termination at the edge of the package, pullback (L1) may be present. L minus L1 to be $\geq 0.33\text{mm}$.
13. For variations with more than one lead count for a given body size and terminal pitch, each lead count for that variation is denoted by a dash number (e.g., -1 or -2).

16-pin QFN 3x3 Dimensions				
Symbol	Min	Nom	Max	Notes
aaa		0.15		1, 2
bbb		0.10		1, 2
ccc		0.10		1, 2
ddd		0.05		1, 2
b	0.18	0.25	0.30	1, 2
e		0.50		
A	0.80	0.90	1.00	1, 2
A1	0.00	0.02	0.05	1, 2
A3		0.20 REF		1, 2
L1	0.03		0.15	1, 2
D BSC		3.00		1, 2, 10
E BSC		3.00		1, 2, 10
D2	1.30	1.45	1.55	1, 2, 10
E2	1.30	1.45	1.55	1, 2, 10
L	0.30	0.40	0.50	1, 2, 10
N		16		1, 2, 10
ND		4		1, 2, 10
NE		4		1, 2, 10

12-pin QFN 4x4 Dimensions				
Symbol	Min	Nom	Max	Notes
aaa		0.15		1, 2
bbb		0.10		1, 2
ccc		0.10		1, 2
ddd		0.05		1, 2
b	0.25	0.30	0.35	1, 2
e		0.80		
A	0.80	0.90	1.00	1, 2
A1	0.00	0.02	0.05	1, 2
A3		0.20 REF		1, 2
L1	0.03		0.15	1, 2
D BSC		4.00		1, 2, 10
E BSC		4.00		1, 2, 10
D2	2.00	2.15	2.25	1, 2, 10
E2	2.00	2.15	2.25	1, 2, 10
L	0.45	0.55	0.65	1, 2, 10
N		12		1, 2, 10
ND		3		1, 2, 10
NE		3		1, 2, 10

9 Ordering Information

The AS1357 is available with preset LDO output voltages or customer-specific versions (with a minimum order quantity of 30,000). Each customer-specific device is factory trimmed to the desired output voltage (see Table 9).

Table 4. Ordering Information

Part	LDO Values	Delivery Form	Package
AS1357-T	User-programmable LDO values ¹	Tape and Reel	12-pin QFN 4x4
AS1357	User-programmable LDO values ¹	Tray	12-pin QFN 4x4
AS1357V-T ²	User-programmable LDO values ¹	Tape and Reel	16-pin QFN 3x3
AS1357V ²	User-programmable LDO values ¹	Tray	16-pin QFN 3x3
AS1357_A7A-T	V _{OUT1} = 2.8V, V _{OUT2} = 2.5V, V _{OUT3} = 2.8V	Tape and Reel	12-pin QFN 4x4
AS1357_uxy-T ^{3, 4}	Customer-specific LDO values	---	12-pin QFN 4x4
AS1357V_uxy-T ^{2, 3, 4}	Customer-specific LDO values	---	16-pin QFN 3x3

1. The values are programmed via the AS1352/57 programming board.
2. Available upon request. Contact austriamicrosystems, AG for more information.
3. Customer-specific values are as follows:
 - u* = Customer-specific V_{OUT1} value suffix.
 - x* = Customer-specific V_{OUT2} value suffix.
 - y* = Customer-specific V_{OUT3} value suffix.
4. "-T" suffix for tape and reel, no suffix for tray delivery form.

Table 5. Output Voltages Suffix Guide

Part	Suffix	Output Voltage
AS1357_uxy	F	3.3 V
	E	3.2 V
	D	3.1 V
	C	3.0 V
	B	2.9 V
	A	2.8 V
	9	2.7 V
	8	2.6 V
	7	2.5 V
	6	2.4 V
	5	2.3 V
	4	2.2 V
	3	2.1 V
	2	2.0 V
	1	1.9 V
0	1.8 V	

Copyrights

Copyright © 1997-2007, austriamicrosystems AG, Schloss Premstaetten, 8141 Unterpremstaetten, Austria-Europe. Trademarks Registered ®. All rights reserved. The material herein may not be reproduced, adapted, merged, translated, stored, or used without the prior written consent of the copyright owner.

All products and companies mentioned are trademarks or registered trademarks of their respective companies.

Disclaimer

Devices sold by austriamicrosystems AG are covered by the warranty and patent indemnification provisions appearing in its Term of Sale. austriamicrosystems AG makes no warranty, express, statutory, implied, or by description regarding the information set forth herein or regarding the freedom of the described devices from patent infringement. austriamicrosystems AG reserves the right to change specifications and prices at any time and without notice. Therefore, prior to designing this product into a system, it is necessary to check with austriamicrosystems AG for current information. This product is intended for use in normal commercial applications. Applications requiring extended temperature range, unusual environmental requirements, or high reliability applications, such as military, medical life-support or life-sustaining equipment are specifically not recommended without additional processing by austriamicrosystems AG for each application. For shipments of less than 100 parts the manufacturing flow might show deviations from the standard production flow, such as test flow or test location.

The information furnished here by austriamicrosystems AG is believed to be correct and accurate. However, austriamicrosystems AG shall not be liable to recipient or any third party for any damages, including but not limited to personal injury, property damage, loss of profits, loss of use, interruption of business or indirect, special, incidental or consequential damages, of any kind, in connection with or arising out of the furnishing, performance or use of the technical data herein. No obligation or liability to recipient or any third party shall arise or flow out of austriamicrosystems AG rendering of technical or other services.



Contact Information

Headquarters

austriamicrosystems AG
A-8141 Schloss Premstaetten, Austria

Tel: +43 (0) 3136 500 0
Fax: +43 (0) 3136 525 01

For Sales Offices, Distributors and Representatives, please visit:

<http://www.austriamicrosystems.com/contact>