

MOTIX™ 48 V/24 V bridge driver

Features

- Drive B6-bridge for BLDC motors in 24 V/48 V platforms with protection features
- Compatible with general microcontroller and **MOTIX™ MCU**
- High voltage capability/robustness up to 100 V helps to simplify PCB design
- 16-bit serial peripheral interface
- Charge pump concept to support 100% duty cycle
- Undervoltage shutdown
- Overvoltage shutdown
- Overtemperature protection
- Drain-source monitoring
- Timeout watchdog
- Cross-current protection
- Off-state diagnostic
- Adaptive MOSFET control

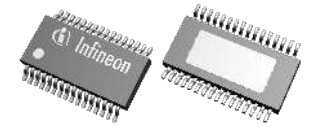

Potential applications

- Can be used to drive B6-bridge for BLDC motors with battery voltage up to 72 V (load dump) for 24 V/48 V applications for example engine cooling fan, water pump and oil pump
- Can be used together with general microcontroller to transfer the applications to 24 V/48 V platforms
- Can be used together with **MOTIX™ MCU** to transfer the applications to 24V/48V platforms with minor software development effort

Product validation

Qualified for automotive applications.

Product validation according to AEC-Q100.

Description

This device is a 48 V MOSFET gate driver compatible with general microcontrollers and **MOTIX™ MCU** to drive max. 3 half-bridges in 24 V/48 V platform. It provides protection features and the possibility to use the diagnosis features integrated in the **MOTIX™ MCU**.

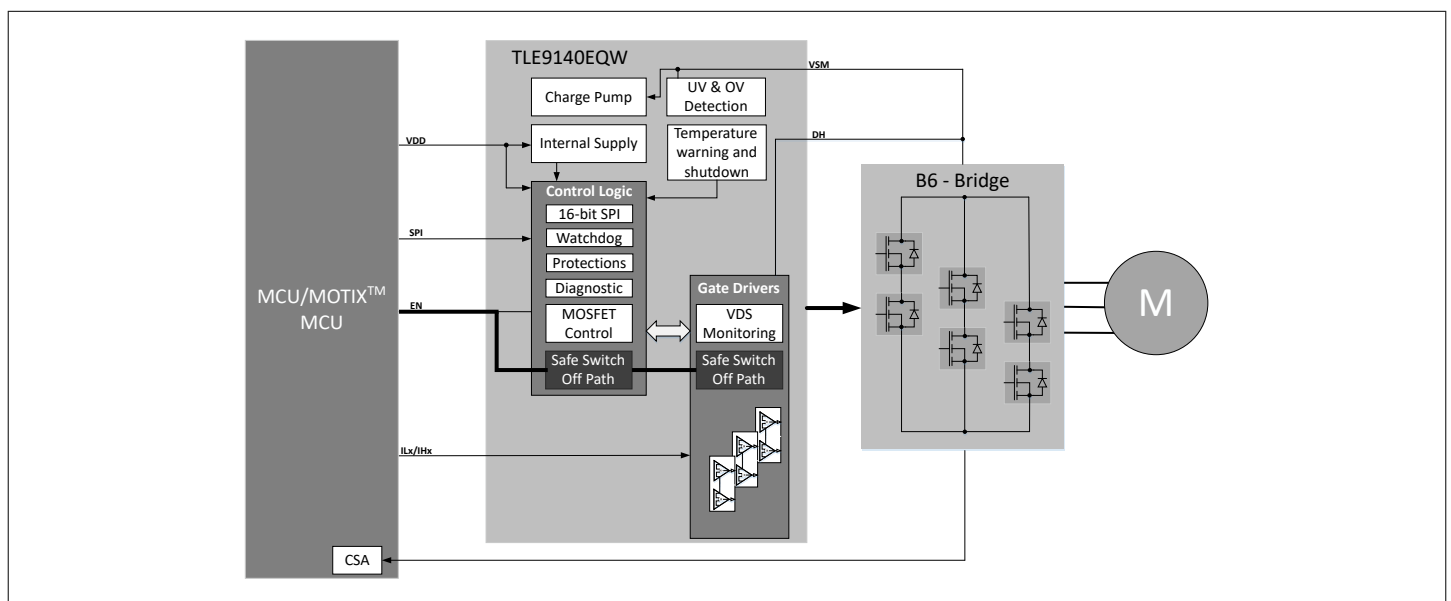

Description

Table 1 **Product summary**

Parameter	Symbol	Value
Specified supply voltage range	$V_{S(nor)}$	8.0 V to 72 V
Max. total charge driver capability	Q_{tot_max}	231 nC * 6 @ 25 kHz
Max. undervoltage threshold	V_{SUV_ON}	20.0 V/8.0 V
Min. overvoltage threshold	V_{SOV_ON}	72.0 V/48.0 V
Max. total quiescent current	$I_{DDQ} + I_{SQ}$	26 μ A

Package	Marking
PG-TSDSO-32	TLE9140EQW

Table of contents

	Table of contents	3
1	Block diagram	5
2	Pin configuration	6
3	General product characteristics	8
3.1	Absolute maximum ratings	8
3.2	Functional range	10
3.3	Thermal resistance	10
4	General description	11
4.1	Operation modes	11
4.1.1	Normal mode	11
4.1.2	Sleep mode	12
4.1.3	Stop mode	12
4.2	Reset behavior	12
4.3	Power supply	12
4.4	Electrical characteristics	13
5	Protections and diagnostics	19
5.1	Reverse polarity protection	19
5.2	Drain-source voltage monitoring	19
5.3	Overtemperature protection	20
5.4	Input error	21
5.5	Off-state diagnostic	21
5.6	Timeout watchdog	22
5.7	Cross-current protection and drain-source overvoltage blank time	23
5.7.1	Cross-current protection	23
5.7.2	Drain-source overvoltage blank time	24
5.8	Overvoltage and undervoltage shutdown	24
5.8.1	VSM undervoltage	24
5.8.2	VSM overvoltage	26
5.8.3	VDD undervoltage protection	27
5.8.4	Charge pump undervoltage	28
5.9	Electrical characteristics protection and diagnosis	29
6	Gate driver	32
6.1	Gate driver control	32
6.2	Electrical characteristics of gate driver	39
7	BEMF comparator	44
8	Serial Peripheral Interface - SPI	45
8.1	SPI description	45

Table of contents

8.2	Global error flag	46
8.3	Global status byte	47
8.4	SPI error detection	48
8.5	Electrical characteristics SPI	51
9	Register specification	54
9.1	Register overview	54
9.2	Control Registers	55
9.2.1	General control register 1	55
9.2.2	General control register 2	56
9.2.3	General control register 3	57
9.2.4	General control register 4	58
9.2.5	General control register 5	60
9.2.6	General control register 6	62
9.2.7	General control register 7	65
9.2.8	General control register 8	67
9.2.9	General control register 9	69
9.2.10	General control register 10	71
9.2.11	General control register 11	74
9.2.12	General control register 12	75
9.2.13	General control register 13	76
9.3	Status registers	77
9.3.1	General status register	78
9.3.2	Global status register 1	79
9.3.3	Global status register 2	80
9.3.4	Global status register 3	80
9.3.5	Global status register 4	81
9.3.6	Effective MOSFET turn-on/-off delay	82
9.3.7	Effective MOSFET rise/fall times	86
10	Application figure	91
11	Package outline	95
12	Revision history	96
	Disclaimer	100

1 Block diagram

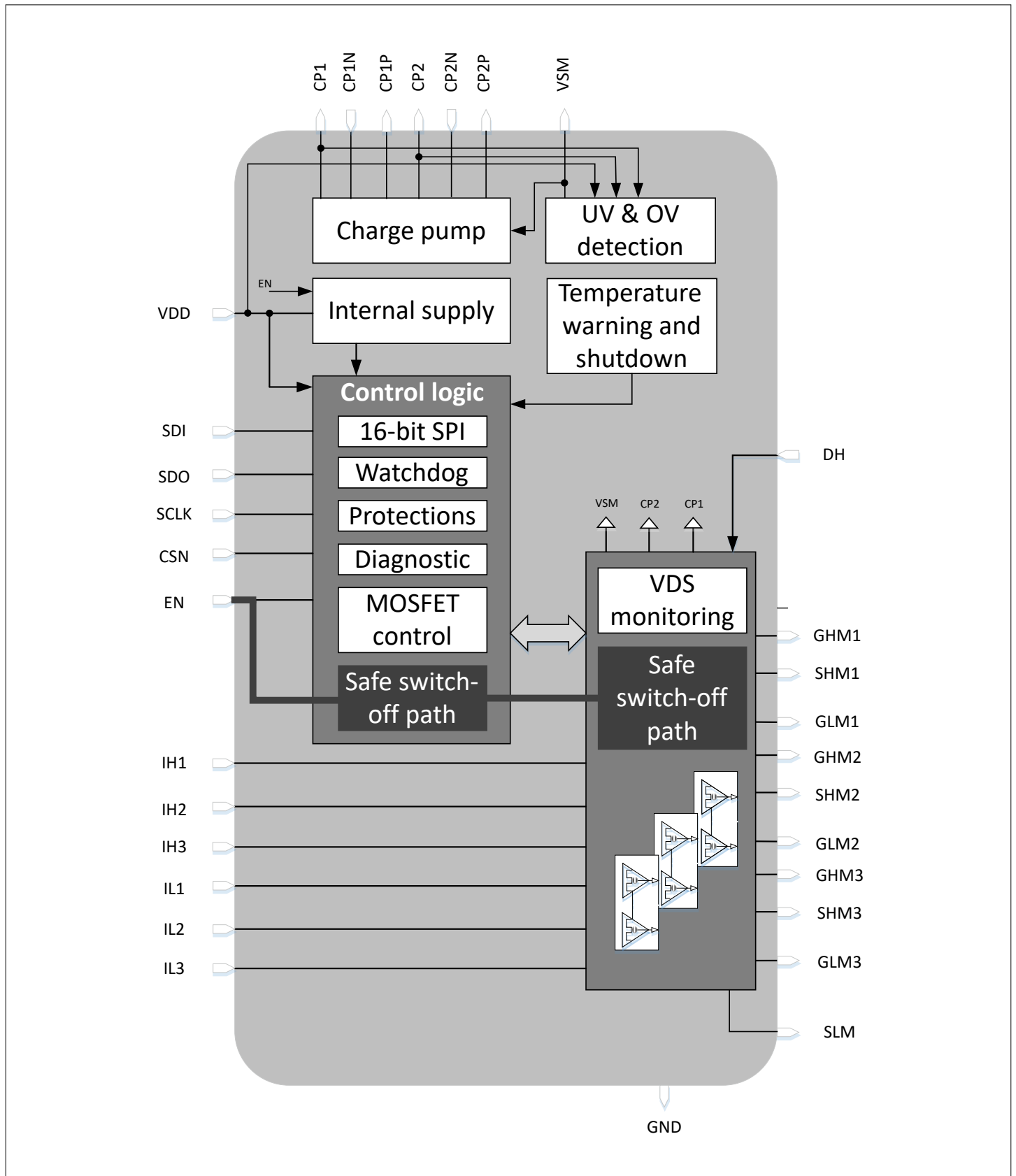

Figure 1 Block diagram

2 Pin configuration

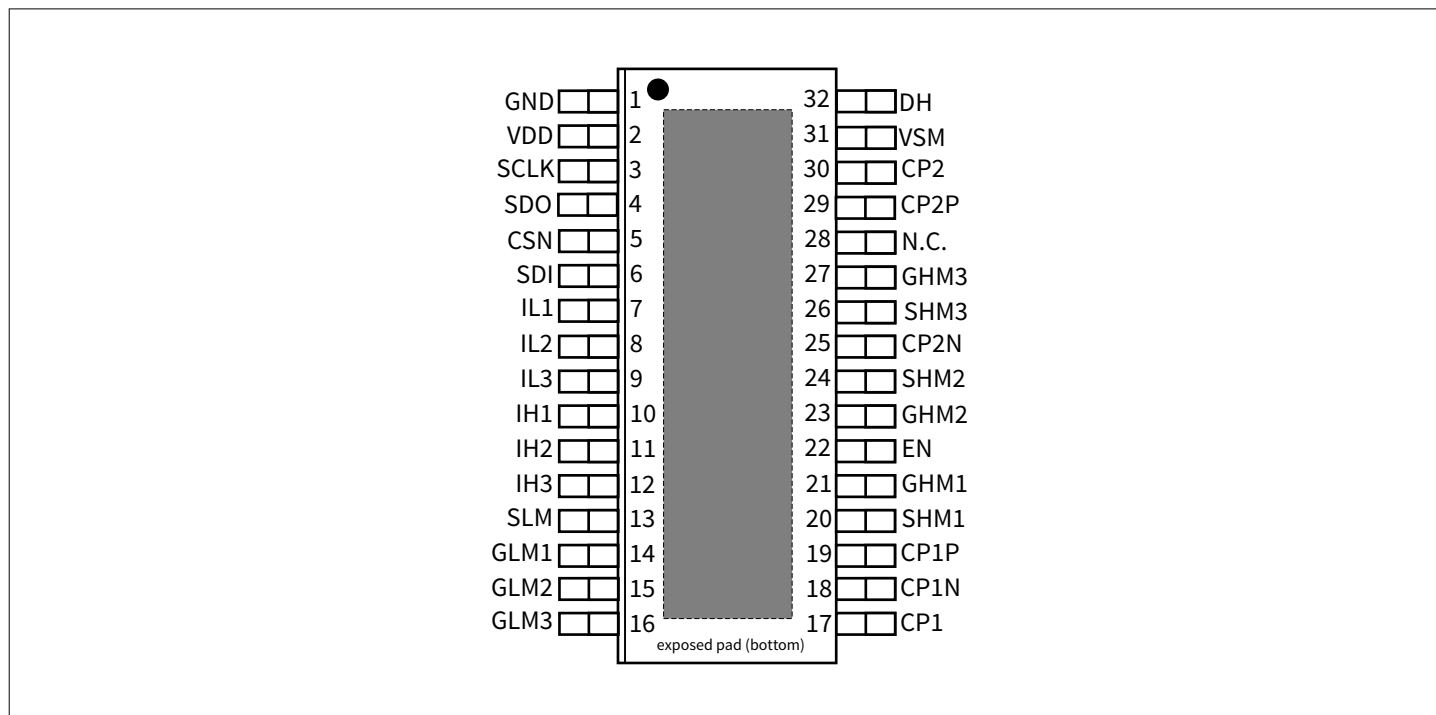

Figure 2 Pin configuration

Table 2 Pin definitions and functions

Pin	Symbol	Function
1	GND	Ground
2	VDD	VDD supply voltage (connect to MCU/MOTIX™ MCU) Power supply for digital circuits
3	SCLK	Serial clock input (connect to MCU/MOTIX™ MCU)
4	SDO	Serial data output (connect to MCU/MOTIX™ MCU)
5	CSN	Chip select not (connect to MCU/MOTIX™ MCU)
6	SDI	Serial data input (connect to MCU/MOTIX™ MCU)
7	IL1	Low-side 1 gate control (connect to MCU/MOTIX™ MCU)
8	IL2	Low-side 2 gate control (connect to MCU/MOTIX™ MCU)
9	IL3	Low-side 3 gate control (connect to MCU/MOTIX™ MCU)
10	IH1	High-side 1 gate control ((connect to MCU/MOTIX™ MCU)
11	IH2	High-side 2 gate control (connect to MCU/MOTIX™ MCU)
12	IH3	High-side 3 gate control (connect to MCU/MOTIX™ MCU)
13	SLM	Source low-side Common connection to the source of the low-side MOSFETs
14	GLM1	Gate low-side 1
15	GLM2	Gate low-side 2

(table continues...)

Table 2 (continued) Pin definitions and functions

Pin	Symbol	Function
16	GLM3	Gate low-side 3
17	CP1	Output of charge pump 1
18	CP1N	Negative connection to charge pump capacitor 1
19	CP1P	Positive connection to charge pump capacitor 1
20	SHM1	Source high-side 1
21	GHM1	Gate high-side 1
22	EN	Enable
23	GHM2	Gate high-side 2
24	SHM2	Source high-side 2
25	CP2N	Negative connection to charge pump capacitor 2
26	SHM3	Source high-side 3
27	GHM3	Gate high-side 3
28	N.C.	Unconnected pin
29	CP2P	Positive connection to charge pump capacitor 2
30	CP2	Output of charge pump 2
31	VSM	Voltage supply Connect to supply voltage (battery) with reverse polarity protection circuit
32	DH	Drain high-side Connect to the drain of high-side MOSFETs

3 General product characteristics

3.1 Absolute maximum ratings

Table 3 Absolute maximum ratings

$T_j = -40^{\circ}\text{C}$ to 175°C ; all voltages with respect to ground, positive current flowing into pin (unless otherwise specified)

Parameter	Symbol	Values			Unit	Note or condition	P-Number
		Min.	Typ.	Max.			
Voltages							
Supply voltage	V_{SM}	-0.3	–	78	V	–	P_GPC_01_01
Logic supply voltage	V_{DD}	-0.3	–	5.5	V	–	P_GPC_01_02
Logic input voltages (IHx, ILx)	V_{ILx}, V_{IHx}	-0.3	–	20	V	–	P_GPC_01_03
Logic input voltages (SCLK, CSN)	V_{SCLK}, V_{CSN}	-0.3	–	$V_{DD} + 0.3$	V	–	P_GPC_01_04
Logic input voltages (SDI)	V_{SDI}	-0.3	–	$V_{DD} + 0.3$	V	$I < 10\text{mA}$	P_GPC_01_05
Logic input voltages (EN)	V_{EN}	-0.3	–	$V_{DD} + 0.3$	V	$I < 10\text{mA}$	P_GPC_01_06
Voltage at SDO	V_{SDO}	-0.3	–	$V_{DD} + 0.3$	V	–	P_GPC_01_07
Voltage range at DH	V_{DH}	-0.3	–	90	V	–	P_GPC_01_08
Voltage range at GHMx	V_{GHMx}	-10.0	–	100	V	–	P_GPC_01_09
Dynamic voltage range at GHMx	V_{GHMx}	–	–	110	V	$< 500\text{ ns}$	P_GPC_01_10
Voltage range at SHMx	V_{SHMx}	-10.0	–	100	V	–	P_GPC_01_11
Dynamic voltage range at SHMx	V_{SHMx}	–	–	110	V	$< 500\text{ ns}$	P_GPC_01_12
Voltage range at GLMx	V_{GLMx}	-7.0	–	20	V	–	P_GPC_01_13
Voltage range at SLM	V_{SLM}	-7.0	–	6.0	V	–	P_GPC_01_14
Voltage difference between GHMx-SHMx and GLMx-SLM	V_{GSM}	-0.3	–	13	V	–	P_GPC_01_15
Voltage range at charge pump pin CP1	V_{CP1}	-0.3	–	20	V	–	P_GPC_01_16

(table continues...)

Table 3 (continued) Absolute maximum ratings

$T_j = -40^\circ\text{C}$ to 175°C ; all voltages with respect to ground, positive current flowing into pin (unless otherwise specified)

Parameter	Symbol	Values			Unit	Note or condition	P-Number
		Min.	Typ.	Max.			
Voltage range at charge pump pin CP1N	V_{CP1N}	-0.3	–	$V_{CP1} + 0.3$	V	–	P_GPC_01_17
Voltage range at charge pump pin CP1P	V_{CP1P}	-0.3	–	78	V	–	P_GPC_01_25
Voltage difference between VSM and CP1N pins	$V_{SM} - V_{CP1N}$	-0.3	–	V_{SM}	V	–	P_GPC_01_26
Voltage range at charge pump pin CP2P	V_{CP2P}	$V_{SM} - 0.3$	–	100	V	–	P_GPC_01_18
Voltage range at charge pump pin CP2	V_{CP2}	$V_{SM} - 0.6$	–	100	V	–	P_GPC_01_19
Voltage range at charge pump pin CP2N	V_{CP2N}	-0.3	–	100	V	–	P_GPC_01_20

Temperatures

Junction temperature	T_j	-40	–	175	$^\circ\text{C}$	–	P_GPC_01_21
----------------------	-------	-----	---	-----	------------------	---	-------------

ESD susceptibility

ESD susceptibility all pins 1	$V_{ESDHBM1}$	-2	–	2	kV	HBM ¹⁾	P_GPC_01_22
ESD susceptibility all pins 2	$V_{ESDCDM1}$	-500	–	500	V	CDM ²⁾	P_GPC_01_23
ESD susceptibility pin corner pins	$V_{ESDCDM2}$	-750	–	750	V	CDM ²⁾	P_GPC_01_24

1) ESD susceptibility, HBM according to ANSI/ESDA/JEDEC JS001 (1.5 k Ω , 100 pF).

2) ESD susceptibility, Charged device model (CDM) according JEDEC JESD22-C101.

3.2 Functional range

Table 4 Functional range

$T_j = -40^\circ\text{C}$ to 175°C ; all voltages with respect to ground, positive current flowing into pin (unless otherwise specified)

Parameter	Symbol	Values			Unit	Note or condition	P-Number
		Min.	Typ.	Max.			
Supply voltage range for normal operation	$V_{SM(nor)}$	8.0	–	60	V	–	P_GPC_02_01
Extended supply voltage range	$V_{SM(ext)}$	8.0	–	75	V	Note: All parameters are specified with the condition $8.0\text{ V} < V_{SM} < 60\text{ V}$. They may have deviations in extended supply voltage range.	P_GPC_02_02
Voltage range at DH	V_{DH}	8.0	–	85	V	–	P_GPC_02_03
Logic supply voltage	V_{DD}	3.0	–	5.5	V	–	P_GPC_02_04
Junction temperature	T_j	-40	–	150	$^\circ\text{C}$	–	P_GPC_02_05
Extended junction temperature	T_{j_ext}	-40	–	175	$^\circ\text{C}$	–	P_GPC_02_06

3.3 Thermal resistance

Table 5 Thermal resistance

Parameter	Symbol	Values			Unit	Note or condition	P-Number
		Min.	Typ.	Max.			
Junction to case	R_{thJC}	–	1.93	–	k/W	$T_a = 85^\circ\text{C}$	P_GPC_03_01
Junction to ambient	R_{thJA}	–	27.12	–	k/W	$T_a = 85^\circ\text{C}$; Package on JEDEC 2s2p with thermal VIAs	P_GPC_03_02

4 General description

4.1 Operation modes

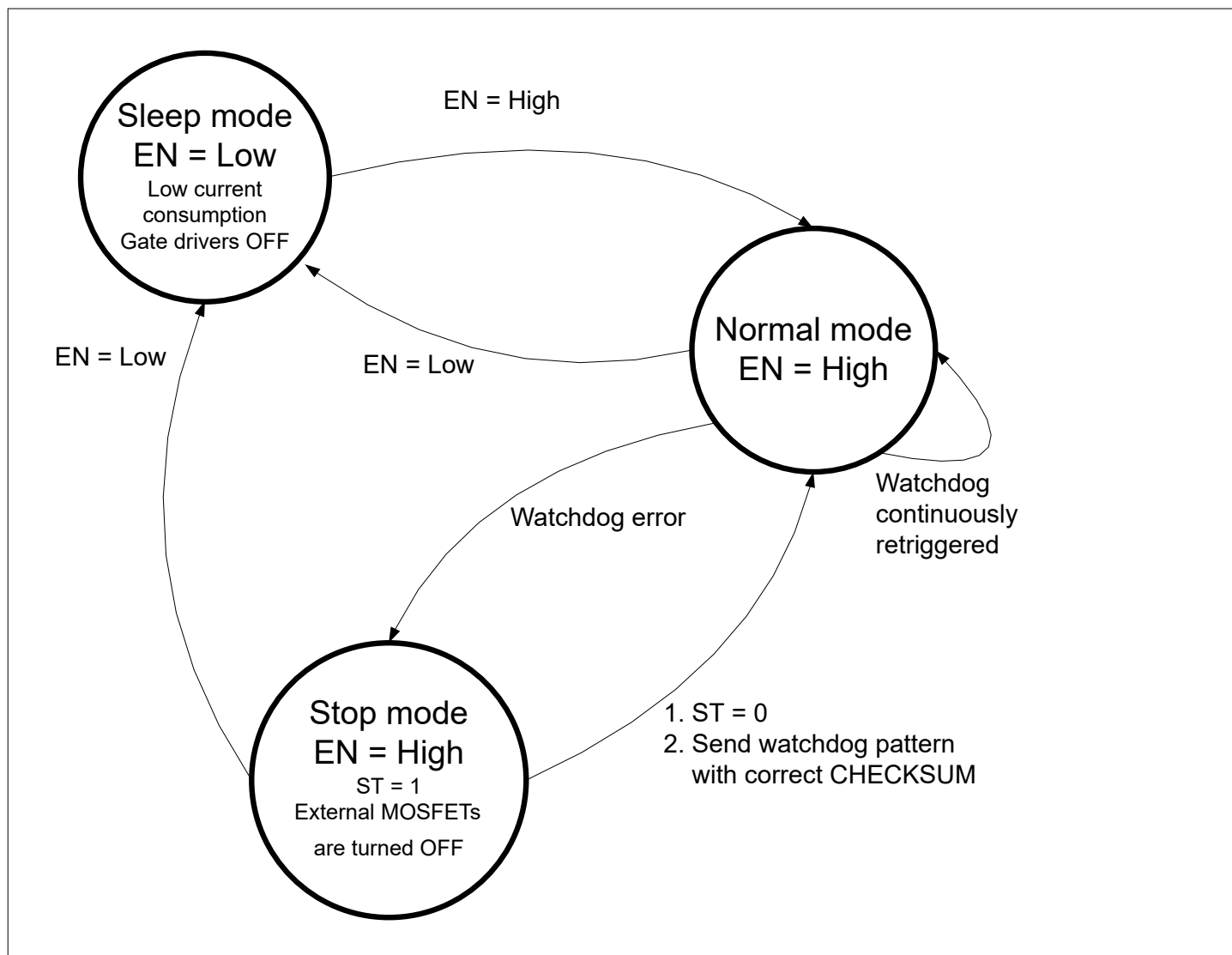

Figure 3 State diagram

4.1.1 Normal mode

The device enters normal operation mode if EN pin is set to high for a duration longer than SPI setup time t_{SET_SPI} . The device will stay in the normal operation mode if the watchdog is retriggered in the defined watchdog period and the EN is kept to high.

In normal operation mode, the device behaves as follows:

- All functions and all diagnostics are available
- The output drivers can be enabled and configured through the SPI in error free condition

Note: In case of SPI error, the SPI frame which contains an error will be ignored and the SPIE bit will be set. The next valid SPI frame will be accepted, but the SPIE bit remains until it is cleared by the SPI command.

4.1.2 Sleep mode

Sleep mode is a low power mode with quiescent current of V_{DD} and V_{SM} reduced respectively to I_{DD_Q} and I_{SMQ} . If EN is set to low for a duration longer than EN filter time t_{EN_FILT} , the device will:

- Turn-off the external MOSFETs actively
- Enter sleep mode with a delay defined by t_{DSLEEP}

In sleep mode, the device behaves as follows:

- Turn-off the external MOSFETs with pull down resistors
- Deactivate the internal circuits and the power supply structure
- Reset the SPI registers

4.1.3 Stop mode

In case of watchdog error, the device will:

- Turn-off external MOSFETs
- Set ST bit (see [STAT](#) and [Global status byte](#))
- Enter stop mode

In stop mode, the device behaves as follows:

- The control registers are reset to default values
- Any write command or clear command (except ST bit in [STAT](#)) will be discarded
- A clear command to status registers does not reset any failure flag except ST bit in [STAT](#)
- Control and status registers are allowed to be read in this mode

The device will resume normal mode from stop mode if the microcontroller executes the following sequence:

1. Clear the ST bit in [STAT](#)
2. Send watchdog pattern with correct CHECKSUM bit

Note: Only a correct SPI protocol transaction in between can interrupt the exit sequence.

4.2 Reset behavior

The device resumes normal operation mode, and the nPOR bit in [STAT](#) and [Global status byte](#) is reset to 0 to report the reset condition if the following conditions are fulfilled:

- EN is set to high for a duration longer than t_{SET_SPI}
- $V_{DD} > V_{DD_POR}$

In case of V_{DD} undervoltage, if V_{DD} is rising above V_{DD_POR} again, the device behaves as follows:

- Reset the digital block
- Set NPOR bit to 0 to report the reset condition
- Resume normal operation mode

4.3 Power supply

The device is supplied by V_{DD} and V_{SM} . The V_{DD} supplies the digital I/O ports, and V_{SM} supplies the buck/boost charge pump (charge pump 1) and the single stage charge pump (charge pump 2).

The output of the buck/boost charge pump (CP1) is regulated at V_{CP1} , and supplies:

- The low side gate drivers
- The single stage charge pump

The output voltage of the single stage CP2 is used to supply the high side gate drivers.

4 General description

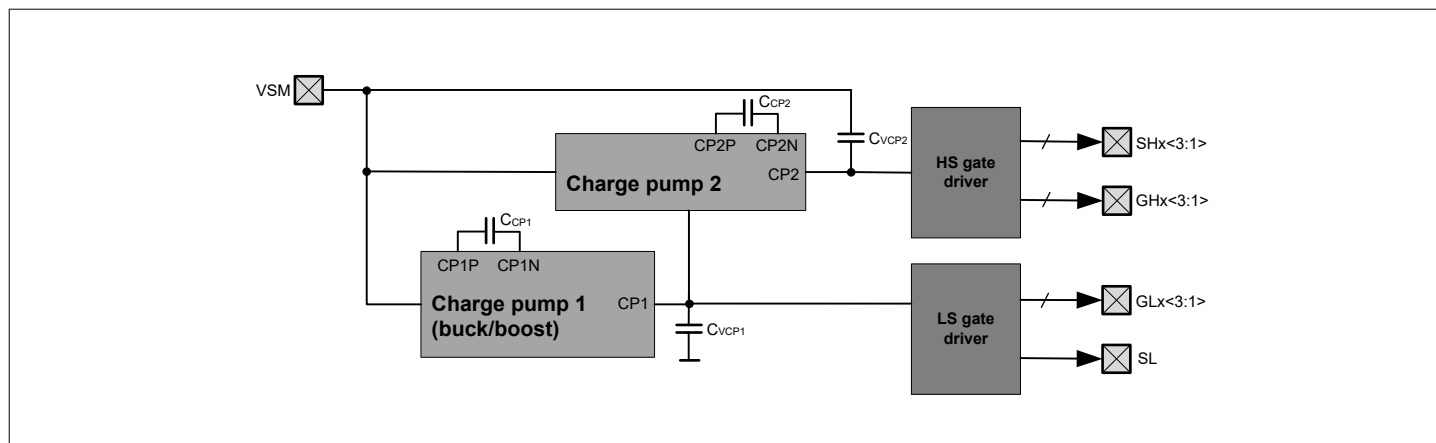

Figure 4 Power supply

4.4 Electrical characteristics

Table 6 Supply

$V_{SM} = 8.0\text{ V to }60\text{ V}$, $T_j = -40^\circ\text{C to }+175^\circ\text{C}$, all voltages with respect to ground, positive current flowing into pin (unless otherwise specified)

Parameter	Symbol	Values			Unit	Note or condition	P-Number
		Min.	Typ.	Max.			
Current consumption, EN = low							
Supply quiescent current	I_{SMQ}	–	7	15	μA	$T_j < 85^\circ\text{C}$	P_GEN_01_01
Supply quiescent current extended	I_{SMQ_EXT}	–	–	40	μA	$150^\circ\text{C} < T_j \leq 175^\circ\text{C}$	P_GEN_01_03
Logic supply quiescent current	I_{DDQ}	–	3	10	μA	$T_j < 85^\circ\text{C}$	P_GEN_01_04
Logic supply quiescent current extended	I_{DDQ_EXT}	–	–	120	μA	$150^\circ < T_j \leq 175^\circ\text{C}$	P_GEN_01_06
Total quiescent current	$I_{DDQ} + I_{SMQ}$	–	8.5	26	μA	$T_j < 85^\circ\text{C}$	P_GEN_01_07
Sleep mode delay	t_{DSLEEP}	2.5	4.4	10	μs	–	P_GEN_01_08
EN low filter time	t_{EN_FILT}	1	2.4	4.5	μs	–	P_GEN_01_09
Current consumption, EN = high							
Supply current	I_{SM_NOR1}	–	125	150	mA	$13\text{ V} < V_{SM} < 19\text{ V}$, BD_EN = 1b, $I_{Load_CP1} = 19.1\text{ mA}$, $I_{Load_CP2} = 19.1\text{ mA}$	P_GEN_01_20
Supply current	I_{SM_NOR2}	–	62	85	mA	$19\text{ V} < V_{SM} < 60\text{ V}$, BD_EN = 1b, $I_{Load_CP1} = 19.1\text{ mA}$, $I_{Load_CP2} = 19.1\text{ mA}$	P_GEN_01_21

(table continues...)

4 General description

Table 6 (continued) Supply

$V_{SM} = 8.0\text{ V to }60\text{ V}$, $T_j = -40^\circ\text{C to }+175^\circ\text{C}$, all voltages with respect to ground, positive current flowing into pin (unless otherwise specified)

Parameter	Symbol	Values			Unit	Note or condition	P-Number
		Min.	Typ.	Max.			
Logic supply current	I_{DD1}	–	3.75	6	mA	$T_j \leq 150^\circ\text{C}$; CP_EN = 0b; BD_EN = 0b	P_GEN_01_22

V_S

UV switch ON voltage (VSM_COVUVTH = 000B, 001B, 010B or 011B)	V_{SMUV_ON1}	18	19	20	V	V_{SM} increasing	P_GEN_01_23
UV switch ON voltage (VSM_COVUVTH = 100B)	V_{SMUV_ON2}	7.0	7.5	8.0	V	V_{SM} increasing	P_GEN_01_24
UV switch OFF voltage (VSM_COVUVTH = 000B, 001B, 010B or 011B)	V_{SMUV_OFF1}	17.5	18.5	19.5	V	V_{SM} decreasing	P_GEN_01_25
UV switch OFF voltage (VSM_COVUVTH = 100B)	V_{SMUV_OFF2}	6.5	7.0	7.5	V	V_{SM} decreasing	P_GEN_01_26
UV ON/OFF hysteresis	V_{SMUV_HY}	0.3	0.5	0.7	V	$V_{SMUV_ON} - V_{SMUV_OFF}$	P_GEN_01_27
OV switch ON voltage (VSM_COVUVTH = 000B)	V_{SMCOV_ON1}	53	55	57	V	V_{SM} decreasing	P_GEN_01_28
OV switch ON voltage (VSM_COVUVTH = 001B)	V_{SMCOV_ON2}	55	57	59	V	V_{SM} decreasing	P_GEN_01_29
OV switch ON voltage (VSM_COVUVTH = 010B)	V_{SMCOV_ON3}	57	59	61	V	V_{SM} decreasing	P_GEN_01_30
OV switch ON voltage (VSM_COVUVTH = 011B)	V_{SMCOV_ON4}	59	61	63	V	V_{SM} decreasing	P_GEN_01_31

(table continues...)

4 General description

Table 6 (continued) Supply

$V_{SM} = 8.0\text{ V to }60\text{ V}$, $T_j = -40^\circ\text{C to }+175^\circ\text{C}$, all voltages with respect to ground, positive current flowing into pin (unless otherwise specified)

Parameter	Symbol	Values			Unit	Note or condition	P-Number
		Min.	Typ.	Max.			
OV switch ON voltage (VSM_COVUVTH = 100B)	V_{SMCOV_ON5}	48	50	52	V	V_{SM} decreasing	P_GEN_01_32
Hard OV switch ON voltage	V_{SMOV_ON}	71	74	76	V	V_{SM} decreasing	P_GEN_01_33
OV switch OFF voltage (VSM_COVUVTH = 000B)	V_{SMCOV_OFF1}	54	56	58	V	V_{SM} increasing	P_GEN_01_34
OV switch OFF voltage (VSM_COVUVTH = 001B)	V_{SMCOV_OFF2}	56	58	60	V	V_{SM} increasing	P_GEN_01_35
OV switch OFF voltage (VSM_COVUVTH = 010B)	V_{SMCOV_OFF3}	58	60	62	V	V_{SM} increasing	P_GEN_01_36
OV switch OFF voltage (VSM_COVUVTH = 011B)	V_{SMCOV_OFF4}	60	62	64	V	V_{SM} increasing	P_GEN_01_37
OV switch OFF voltage (VSM_COVUVTH = 100B)	V_{SMCOV_OFF5}	49	51	53	V	V_{SM} increasing	P_GEN_01_38
Hard OV switch OFF voltage	V_{SMOV_OFF}	72	75	77	V	V_{SM} increasing	P_GEN_01_39
OV ON/OFF hysteresis	V_{SMOV_HY}	0.5	1	2	V	$V_{SMOV_ON} - V_{SMOV_OFF}$ or $V_{SMCOV_ONx} - V_{SMCOV_OFFx}$	P_GEN_01_40

V_{DD}

VDD Power-On-Reset	V_{DD_POR}	2.50	2.70	2.90	V	V_{DD} increasing	P_GEN_01_41
VDD Power-Off-Reset	V_{DD_POFFR}	2.40	2.60	2.80	V	V_{DD} decreasing	P_GEN_01_42
VDD Power-On-Reset hysteresis	$V_{DD_POR_HY}$	30	–	–	mV	$V_{DD_POR} - V_{DD_POFFR}$	P_GEN_01_43

4 General description

Table 7 EN

$V_{SM} = 8.0\text{ V to }60\text{ V}$, $T_j = -40^\circ\text{C to }+175^\circ\text{C}$, all voltages with respect to ground, positive current flowing into pin (unless otherwise specified)

Parameter	Symbol	Values			Unit	Note or condition	P-Number
		Min.	Typ.	Max.			
EN high level	V_{ENH}	$0.75 \cdot V_D$	–	V_{DD}	V	–	P_GEN_02_01
EN low level	V_{ENL}	–	–	$0.25 \cdot V_D$	V	–	P_GEN_02_02
EN hysteresis	V_{ENHY}	50	400	–	mV	–	P_GEN_02_03
EN pull-down resistor	R_{PD_EN}	25	40	60	k Ω	–	P_GEN_02_04

Table 8 Charge pumps

$V_{SM} = 8.0\text{ V to }60\text{ V}$, $T_j = -40^\circ\text{C to }+175^\circ\text{C}$, all voltages with respect to ground, positive current flowing into pin (unless otherwise specified)

Parameter	Symbol	Values			Unit	Note or condition	P-Number
		Min.	Typ.	Max.			
Charge pump 1							
Charge pump 1 frequency	f_{CP1}	225	250	275	kHz	–	P_GEN_03_01
Output voltage (13 V < VSM < 60 V): CP1 vs. GND	V_{CP1}	16	18	19.5	V	13 V < V_{SM} < 60 V, $I_{CP1} = 19.1\text{ mA}$, $I_{CP2} = 19.1\text{ mA}$, BD_EN = 1b $-40^\circ\text{C} \leq T_j \leq 150^\circ\text{C}$	P_GEN_03_02
Output voltage HT (13 V < VSM < 60 V): CP1 vs. GND	V_{CP1}	14	16.5	19	V	13 V < V_{SM} < 60 V, $I_{CP1} = 19.1\text{ mA}$, $I_{CP2} = 19.1\text{ mA}$, BD_EN = 1b $150^\circ\text{C} < T_j \leq 175^\circ\text{C}$	P_GEN_03_03
Output voltage (VSM = 8 V): CP1 vs. GND	V_{CP1}	11	12.5	14	V	$V_{SM} = 8\text{ V}$, $I_{CP1} = 5.6\text{ mA}$, $I_{CP2} = 5.6\text{ mA}$, CPEN = 1b, BD_EN = 1b $-40^\circ\text{C} \leq T_j \leq 150^\circ\text{C}$	P_GEN_03_08
Output voltage HT (VSM = 8V): CP1 vs. GND	V_{CP1}	10.7	11.5	12.5	V	$V_{SM} = 8\text{ V}$, $I_{CP1} = 5.6\text{ mA}$, $I_{CP2} = 5.6\text{ mA}$, BD_EN = 1b $150^\circ\text{C} < T_j \leq 175^\circ\text{C}$	P_GEN_03_09
CP1 blanking time	t_{BLK_VCP1}	400	500	600	μs	8.0 V < V_{SM} < 60 V, $C_{VCP1} = 1\text{ }\mu\text{F}$, $C_{CP1} = 470\text{ nF}$, $I_{CP1} = 0$ ¹⁾	P_GEN_03_10

(table continues...)

4 General description

Table 8 (continued) Charge pumps

$V_{SM} = 8.0\text{ V to }60\text{ V}$, $T_j = -40^\circ\text{C to }+175^\circ\text{C}$, all voltages with respect to ground, positive current flowing into pin (unless otherwise specified)

Parameter	Symbol	Values			Unit	Note or condition	P-Number
		Min.	Typ.	Max.			
Rise time of CP1	t_{RISE_VCP1}	–	105	300	μs	$8.0\text{ V} < V_{SM} < 60\text{ V}$ (25% to 75%), $C_{CP1} = 470\text{ nF}$, $I_{CP1} = 0$ ¹⁾	P_GEN_03_11
Charge pump 1 undervoltage threshold	V_{CP1UV}	9.0	10.0	12.0	V	–	P_GEN_03_12
Charge pump 1 undervoltage filter time	t_{CP1UV}	51	64	77	μs	–	P_GEN_03_13
Charge pump 2							
Charge pump 2 frequency	f_{CP2}	225	250	275	kHz	–	P_GEN_03_14
Output voltage (13 V < VSM < 60 V): CP2 vs. VSM	V_{CP2}	11.5	13.5	15.5	V	$13\text{ V} < V_{SM} < 60\text{ V}$, $I_{CP1} = 19.1\text{ mA}$, $I_{CP2} = 19.1\text{ mA}$, $BD_EN = 1b$ $-40^\circ\text{C} \leq T_j \leq 150^\circ\text{C}$	P_GEN_03_15
Output voltage HT (13 V < VSM < 60 V): CP2 vs. VSM	V_{CP2}	10.5	12.5	14	V	$13\text{ V} < V_{SM} < 60\text{ V}$, $I_{CP1} = 19.1\text{ mA}$, $I_{CP2} = 19.1\text{ mA}$, $BD_EN = 1b$ $150^\circ\text{C} < T_j \leq 175^\circ\text{C}$	P_GEN_03_16
Output voltage (VSM = 8 V): CP2 vs. VSM	V_{CP2}	8	9.2	10	–	$V_{SM} = 8\text{ V}$, $I_{CP1} = 5.6\text{ mA}$, $I_{CP2} = 5.6\text{ mA}$, $CPEN = 1b$, $BD_EN = 1b$ $-40^\circ\text{C} \leq T_j \leq 150^\circ\text{C}$	P_GEN_03_21
Output voltage HT (VSM = 8 V): CP2 vs. VSM	V_{CP2}	7.0	7.5	9.0	–	$V_{SM} = 8\text{ V}$, $I_{CP1} = 5.6\text{ mA}$, $I_{CP2} = 5.6\text{ mA}$, $CPEN = 1b$, $BD_EN = 1b$ $150^\circ\text{C} < T_j \leq 175^\circ\text{C}$	P_GEN_03_22
Turn-on time of CP2	t_{ON_VCP2}	–	450	600	μs	$8.0\text{ V} < V_{SM} < 60\text{ V}$ (25%), $C_{CP2} = 220\text{ nF}$, $I_{CP2} = 0$ ¹⁾ Typ. value at 48V	P_GEN_03_23
Rise time of CP2	t_{RISE_VCP2}	–	150	350	μs	$8.0\text{ V} < V_{SM} < 60\text{ V}$ (25% to 75%), $C_{CP2} = 220\text{ nF}$, $I_{CP2} = 0$ ¹⁾	P_GEN_03_24
CP2 blanking time	t_{BLK_VCP2}	720	900	1080	μs	$8.0\text{ V} < V_{SM} < 60\text{ V}$, $C_{VCP2} = 470\text{ nF}$, $C_{CP2} = 220\text{ nF}$, $I_{CP1} = 0$ ¹⁾	P_GEN_03_25

(table continues...)
 Datasheet

Table 8 (continued) Charge pumps

$V_{SM} = 8.0\text{ V to }60\text{ V}$, $T_j = -40^\circ\text{C to }+175^\circ\text{C}$, all voltages with respect to ground, positive current flowing into pin (unless otherwise specified)

Parameter	Symbol	Values			Unit	Note or condition	P-Number
		Min.	Typ.	Max.			
Charge pump 2 undervoltage	V_{CP2UV}	6	7	8	V	–	P_GEN_03_26
Charge pump 2 undervoltage filter time	t_{CP2UV}	51	64	77	μs	–	P_GEN_03_27

1) Parameter dependent on the capacitance.

5 Protections and diagnostics

This device provides protection and monitoring functions. All detected errors will be sent back to the general microcontroller or the MOTIX™ MCU via SPI.

5.1 Reverse polarity protection

Although reverse polarity protection is 48 V standard, it could be required by the applications. In case it is required, the following structures can be used:

- For 48 V applications, a simple reverse polarity protection including one diode and one resistor can also be used. Refer to Figure 5
- The output of the charge pump 2 (CP2) can be used to supply an external n-channel MOSFET, building an active reverse polarity protection. Refer to Figure 6

For 24 V applications the solution in Figure 5 is not recommended due to the voltage drop of the resistance.

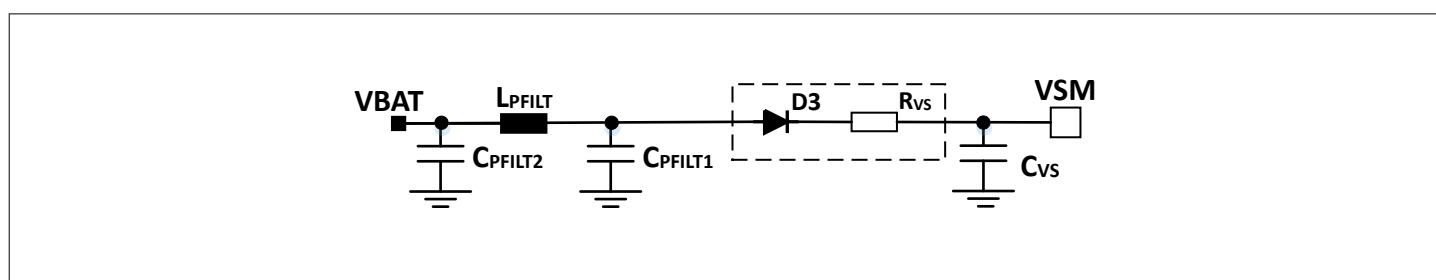

Figure 5 Reverse polarity for 48 V applications

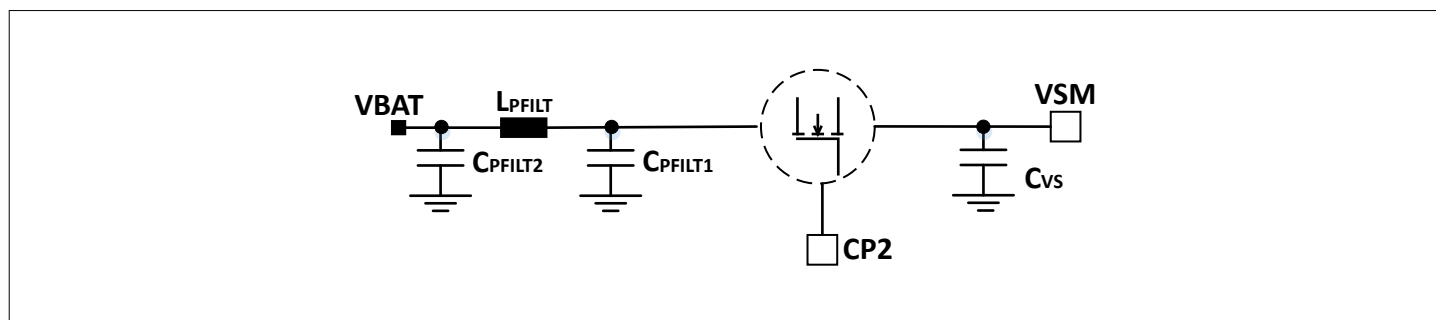

Figure 6 Reverse polarity

5.2 Drain-source voltage monitoring

MOSFETs are protected by V_{DS} monitoring from a short circuit respectively to ground and to battery during on-state:

- HSxDSOV is set to high if the voltage difference between DH and SHMx exceeds the threshold voltage configured by VDSTH (see Table 9)
- LSxDSOV is set to high if the voltage difference between SHMx and SL exceeds the threshold voltage configured by VDSTH (see Table 9)

If a drain-source overvoltage is detected by a voltage comparator when HSLSOV_DIS = 1, the following actions will be performed:

- The gate driver discharge the gate capacitance of the corresponding half-bridge with configured discharge current IDISCHG_ST during TCCP
- The gate capacitance is discharged by IHOLD after TCCP
- The corresponding half bridge will be latched off
- The corresponding bit (LSxDSOV/HSxDSOV) in STAT2 is set

- The DSOV bit in **STAT** and **Global status byte** is set
- The error signal (**GEF**) will be sent back to the general microcontroller or the **MOTIX™ MCU** <https://www.infineon.com/cms/en/product/microcontroller/embedded-power-ics-system-on-chip/-3-phase-bridge-driver-integrated-arm-cortex-m3/> via the SPI

If a drain-source overvoltage is detected by a voltage comparator when **HLSOV_DIS = 0**, the following actions will be performed:

- The gate driver discharge the gate capacitance of the all half-bridges with configured discharge current **IDISCHG_ST** during **TCCP**
- The gate capacitance is discharged by **IHOLD** after **TCCP**
- All half bridge will be latched off
- The corresponding bit (LSxDSOV/HSxDSOV) in **STAT2** is set
- The DSOV bit in **STAT** and **Global status byte** is set
- The error signal (**GEF**) will be sent back to the general microcontroller or the **MOTIX™ MCU** via the SPI

The device reports a drain-source voltage error if both conditions are met:

- After expiration of the blank time
- Drain-source voltage exceeds the configured threshold for a duration longer than the configured filter time

Table 9 Drain-source overvoltage threshold

HBxVDSTH[2:0]	Drain-source overvoltage threshold
000 _B	145 mV
001 _B	195 mV (default)
010 _B	245 mV
011 _B	295 mV
100 _B	390 mV
101 _B	490 mV
110 _B	590 mV
111 _B	2 V

The gate drive resume normal operation once the corresponding bit in **STAT2** is cleared by the microcontroller.

5.3 Overtemperature protection

If the temperature sensor reaches T_{jW} and the **TWDIS** is set to 0, then TW bit in **STAT1**, TE bit in **STAT** and **Global status byte** will be set and latched.

The outputs stages however remain activated. Refer to **Figure 7**.

The TW bit is reset by clearing **STAT1** if the thermal warning condition has disappeared.

If the temperature sensor reaches T_{jSD} , the device behaves as follows:

- Discharge the gate capacitances of the MOSFETs with configured discharge current **IDISCHG_ST**
- All gate drivers are latched off
- Deactivate the charge pump
- Set TSD bit in **STAT1**
- Set TE bit in **STAT** and **Global status byte**

All outputs remain deactivated until the temperature shutdown condition has disappeared and **STAT1** is cleared. See **Figure 7**.

To resume normal functionality of the gate drivers, the following conditions need to be met:

- The temperature shutdown condition has disappeared

- The the general microcontroller or the **MOTIX™ MCU** clears TSD bit in **STAT1**
- The charge pump blanking time t_{BLK_VCPX} and the gate driver filter time t_{GD_filt} expire

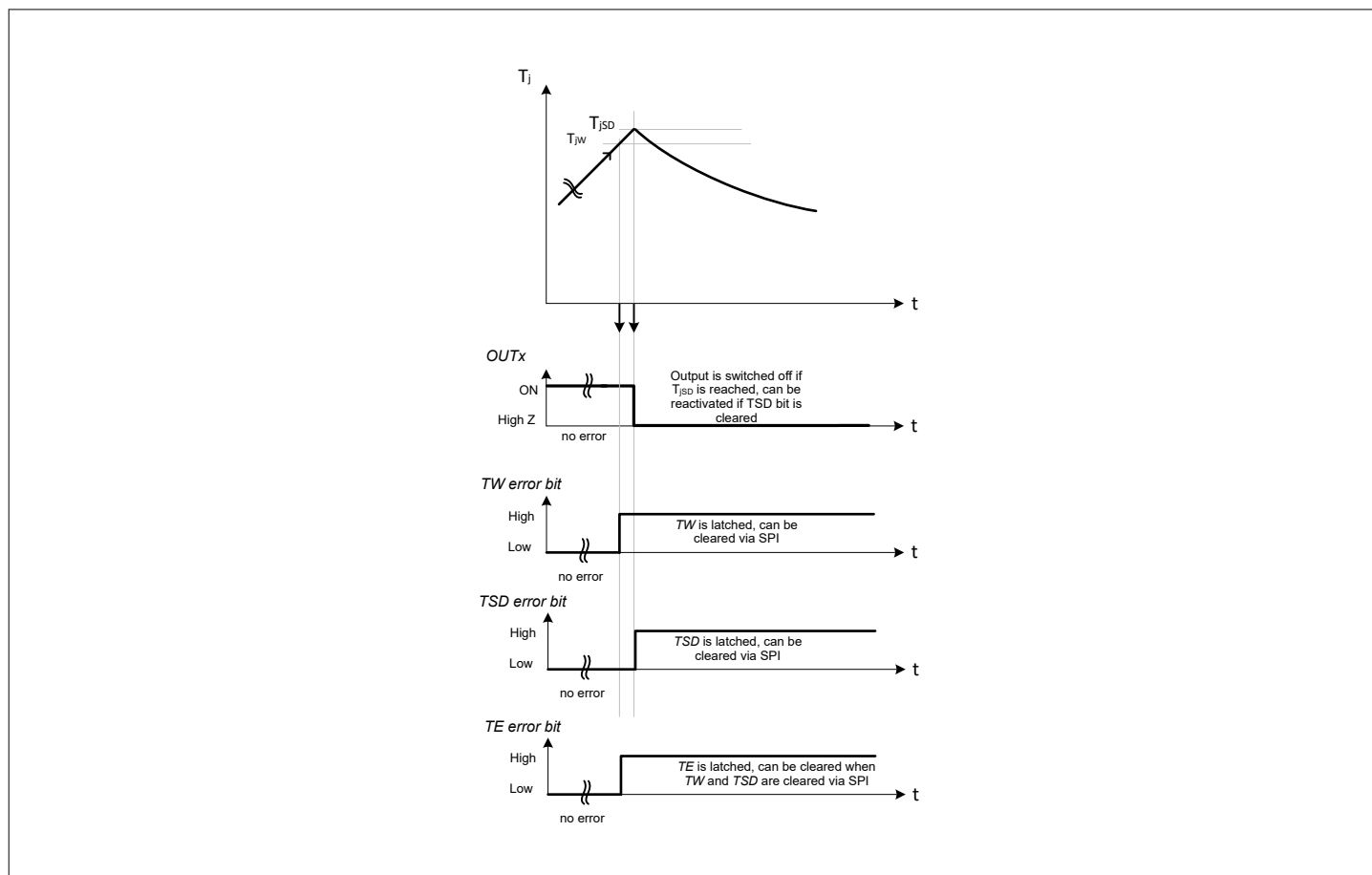

Figure 7 Overtemperature behavior

5.4 Input error

The MOSFETs are protected by input monitoring. When both IHx and ILx of the same bridge are set to high at the same time:

- All external MOSFETs are actively discharged for the duration **TCCP**
- All external MOSFETs are discharged by **IHOLD** after **TCCP**
- INEx bits in **STAT3**, **STAT** and **Global status byte** are set and latched

The gate drivers resume normal operation once the input error disappears and the INEx bits are reset by clearing **STAT3**.

The INE bit is reset by clearing **STAT3**.

5.5 Off-state diagnostic

In order to support the off-state diagnostic, the gate driver of each MOSFET provides pull-up and pull-down currents at the SHx pins.

The pull-up current sources are always active when **BD_EN = 1** and **CPEN = 1** in normal operation mode.

The pull-down currents of each gate driver are activated by the control bits HBxIDIAG in **GENCTRL3**. During the off-state diagnostic routine performed by the general microcontroller or the **MOTIX™ MCU**, the drain-source overvoltage threshold of the relevant half-bridges must be set to 2 V nominal. Refer to **Table 9**. Once the routine is finished, it is highly recommended to decrease the drain-source overvoltage threshold to a lower value, to have a proper VDS monitoring threshold and avoid additional current consumption from the VSM input.

The corresponding HBxVOUT bit in **STAT3** is set if any of the following failures are detected:

- MOSFET short circuit to GND
- MOSFET short circuit the battery
- Open load (disconnected motor)

In normal operation mode the status of the output voltage SHx can be read back with status bit HBxVOUT in **STAT3** when BD_EN = 1, CPEN = 1 and the corresponding half-bridge is in off-state ((IHx, ILx) = (0, 0))

Note: HBxVOUT = 0 if the half-bridge x is not in off-state ((IHx, ILx) = (1, 0) or (0, 1)). INE is reported if ((IHx, ILx) = (1, 1)).

5.6 Timeout watchdog

An integrated timeout watchdog supervises the integrity of the communication with the general microcontroller or the **MOTIX™ MCU**. The watchdog period is programmable by setting the WDPER bits in **GENCTRL2** in the range of 2 ms to 512 ms.

After a power-on-reset, if the watchdog is not retrigged by receiving a valid SPI-write command to the watchdog configuration register (**GENCTRL2**) from the general microcontroller or the **MOTIX™ MCU** in the programmable watchdog period in **GENCTRL2**, the device will:

- Set and latch the ST bit in **STAT** and **Global status byte**
- Reset the control registers to their default values
- Actively switch off all external MOSFETs with **IDISCHG_ST**
- Enter the stop mode

The device resumes normal operation, if the general microcontroller or the **MOTIX™ MCU** device:

1. Clears the ST bit in **STAT** when the device is in stop mode
2. Sends watchdog pattern with correct CHECKSUM bit in normal mode

A checksum bit is part of the SPI command to trigger the watchdog and to set the watchdog setting. The sum of the 8 data bits 7:0 in the register **GENCTRL2** needs to have even parity. This is realized by either setting the bit CHECKSUM to 0 or 1. The checksum is calculated by taking all 8 data bits into account. The written value of the reserved bits of the register is also considered (even if read as 0 in the SPI output) for checksum calculation, that is if a 1 is written on the reserved bit position, then a 1 is used in the checksum calculation.

The SPI command is ignored and SPIE bit is set and latched in **STAT** and **Global status byte**, if the a watchdog trigger with an incorrect CHECKSUM is sent.

$$\text{CHECKSUM} = \text{Bit7} \oplus \dots \oplus \text{Bit0}$$

During normal operation the status bits WDMON[1:0] in **STAT2** report the relative position of the watchdog timer to the watchdog period. Refer to **Table 10** and **Figure 8**.

This allows the detection of a potential latent failure associated to the watchdog timer: the general microcontroller or the **MOTIX™ MCU** can indeed verify that the watchdog timer is running.

Table 10 Watchdog monitoring

WDMON[1:0]	Position of the watchdog timer
00 _B	Watchdog timer is between [0%, 25%] of the watchdog period
01 _B	Watchdog timer is between [25%, 50%] of the watchdog period
10 _B	Watchdog timer is between [50%, 75%] of the watchdog period
11 _B	Watchdog timer is between [75%, 100%] of the watchdog period

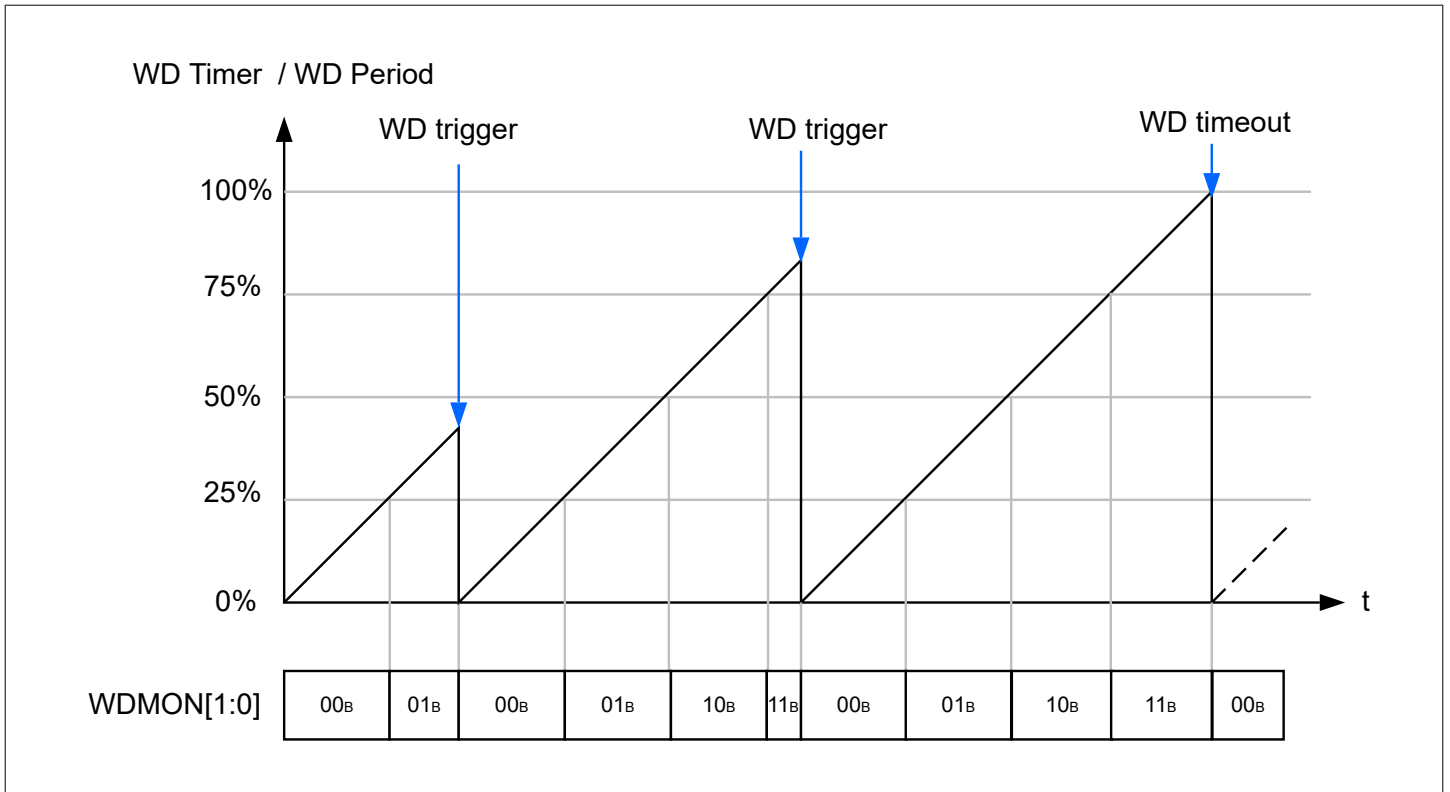

Figure 8 Example of watchdog monitoring and watchdog timeout

The watchdog is enabled by default.

It can be disabled only if the following SPI sequence is sent:

1. First frame: Set UNLOCK bit in [GENCTRL1](#) to 1
Note: UNLOCK is automatically reset to 0 at the end of the next frame.
2. Following frame: Set WDDIS bit in [GENCTRL3](#) to 1

The watchdog is directly re-enabled by setting [WDDIS](#) to 0.

5.7 Cross-current protection and drain-source overvoltage blank time

All gate drivers feature a cross-current protection time and a drain-source overvoltage blank time. The cross-current protection avoids the simultaneous activation of the high-side and the low-side MOSFETs of the same half-bridge. During the blank time, the drain-source overvoltage detection is disabled, to avoid a wrong fault detection during the activation phase of a MOSFET.

5.7.1 Cross-current protection

If IHx/ILx is set to high in the duration of the other input's TCCP, to avoid the cross current the device will:

- Switch on the corresponding MOSFET with a delay defined by cross-current protection time in [GENCTRL12](#)
- Discharge the other MOSFET in the same half bridge actively for a duration defined by the remaining cross-current protection time

Table 11 Cross-current protection time

TCCP[2:0]	Cross-current protection time t_{CCPx} (typical)
000 _B	0.5 μ s
001 _B	1.0 μ s
010 _B	1.5 μ s

(table continues...)

Table 11 (continued) **Cross-current protection time**

TCCP[2:0]	Cross-current protection time t_{CCPx} (typical)
011 _B	2.0 μ s
100 _B	2.5 μ s
101 _B	3.0 μ s
110 _B	3.5 μ s
111 _B	4.0 μ s

5.7.2 Drain-source overvoltage blank time

When the MOSFETs are switched on, after the expiration of the cross-current protection time, a drain-source overvoltage error will be masked during the blank time defined in [GENCTRL12](#) for the drain-source monitoring.

Table 12 **Drain-source overvoltage blank time**

TBLK[2:0]	Drain-source overvoltage blank time t_{BLANKx} (nominal)
000 _B	0.5 μ s
001 _B	1.0 μ s
010 _B	1.5 μ s
011 _B	2.0 μ s
100 _B	2.5 μ s
101 _B	3.0 μ s
110 _B	3.5 μ s
111 _B	4.0 μ s

5.8 Overvoltage and undervoltage shutdown

5.8.1 VSM undervoltage

If VSM drops below V_{SMUV_OFFx} and $V_{DD} > V_{DD_POR}$, the device will:

- Switch off the external MOSFETs actively for the duration [TCCP](#) with the discharge current corresponding to the settings of [IDISCHG_ST](#)
- Deactivate the charge pumps
- Activate passive discharge after [TCCP](#)
- Set and latch VSMUV bit in [STAT1](#)
- Set and latch SUPE bit in [STAT](#) and [Global status byte](#)
- Keep logic information

If VSM rises above V_{SMUV_ONx} as shown in [Figure 9](#), after clearing the VSMUV bit the device resumes normal operation when t_{BLK_VCPx} and t_{GD_filt} expire.

The SUPE is reset if the following conditions are fulfilled:

- $V_{SM} > V_{SMUV_ONx}$ (see [Figure 9](#))
- The device receives a clear command to [STAT1](#)

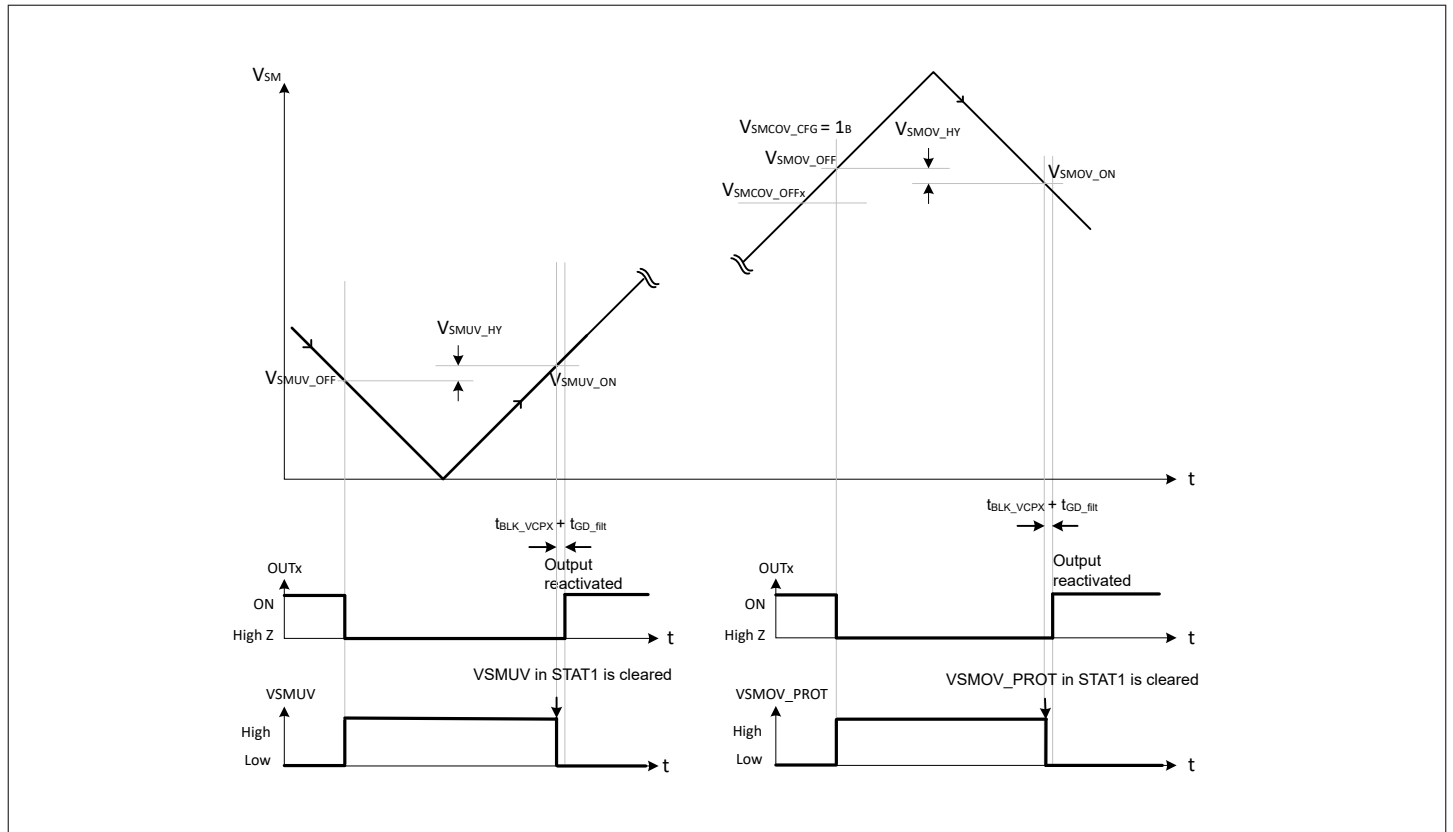

Figure 9 VSM monitoring

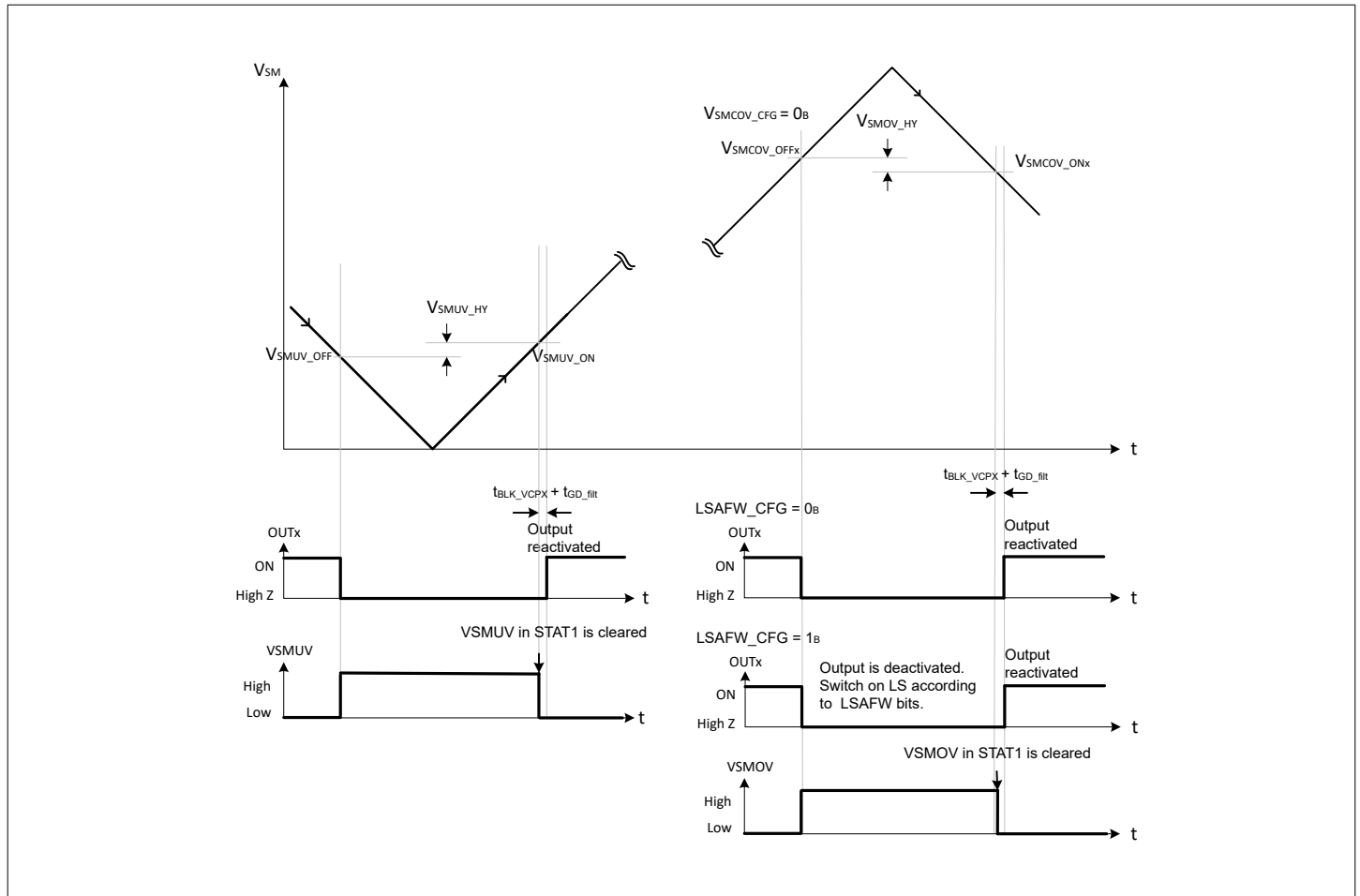

Figure 10 Configurable VSM monitoring

5.8.2 VSM overvoltage

If VSM rises above V_{SMOV_OFF} , $V_{DD} > V_{DD_POR}$, the device will:

- Switch off the external MOSFETs actively for the duration **TCCP** with the discharge current corresponding to the settings of **IDISCHG_ST**
- Deactivate the charge pumps
- Activate passive discharge after TCCP
- Set and latch **VSMOV_PROT** bit in **STAT1**
- Set and latch **SUPE** bit in **STAT** and **Global status byte**
- Keep logic information

A configurable overvoltage threshold below V_{SMCOV_OFFx} can be selected by set **VSM_COVUVTH** bit in **GENCTRL13**.

When the conditions below are met:

- **VSMOV_CFG** is set to 0_B
- VSM rises above the selected V_{SMCOV_OFFx}
- $V_{DD} > V_{DD_POR}$
- **LSAFW_CFG** = 0_B

The device will:

- Switch off the external MOSFETs actively for the duration **TCCP** with the discharge current corresponding to the settings of **IDISCHG_ST**
- Deactivate the charge pumps
- Activate passive discharge after TCCP

- Set and latch VSMOV bit in [STAT1](#)
- Set and latch SUPE bit in [STAT](#) and [Global status byte](#)
- Keep logic information

When the conditions below are met:

- VSMOV_CFG is set to 0_B
- VSM rises above the selected V_{SMCOV_OFFx}
- $VDD > V_{DD_POR}$
- LSAFW_CFG = 1_B

The device will:

- Set and latch VSMOV bit in [STAT1](#)
- Set and latch SUPE bit in [STAT](#) and [Global status byte](#)
- Switch off the external high-side MOSFETs actively for the duration [TCCP](#)
- Switch on the corresponding low-side MOSFET based on the LSAFW bits in [GENCTRL13](#)
- Switch on all low-side MOSFETs if LSAFW = 00_B (the one was in on-state will be kept switched on)
- The low-side MOSFETs will be latched on till the VSMOV bit is cleared
- Keep charge pumps activated with auto-recovery
- Ignore CPREC bit
- Keep logic information

Note: The low-side MOSFETs are switched on based on the same sequence for normal switching on.

When the conditions below are met:

- VSMOV_CFG is set to 1_B
- VSM rises above the selected V_{SMCOV_OFFx}
- $VDD > V_{DD_POR}$

The device will:

- Ignore the configurable overvoltage event
- Not set the VSMOV bit in [STAT1](#)
- Not set SUPE bit in [STAT](#) and [Global status byte](#)
- Keep charge pumps activated
- Keep logic information

If VSM drops below $V_{SMOV_ON} / V_{SMCOV_ONx}$ as shown in [Figure 9](#) and [Figure 10](#), after clearing VSMOV_PROT bit and VSMOV bit the device will resume normal operation when t_{BLK_VCPX} and t_{GD_filt} expires.

The SUPE is reset if the following conditions are fulfilled:

- $VSM < V_{SMOV_ON}$ or $VSM < V_{SMCOV_ONx}$ when VSMOV_CFG is 0_B (see [Figure 9](#) and [Figure 10](#))
- The device receives a clear command to [STAT1](#)

5.8.3 VDD undervoltage protection

If the VDD logic supply drops below the undervoltage threshold V_{DD_POFFR} (power off reset), the device behaves as follows:

- Deactivate the SPI interface
- Reset the digital block
- Switch off the gate driver
- Activate the passive discharge path for the external MOSFETs
- Switch off the charge pump

5.8.4 Charge pump undervoltage

The voltage of the buck/boost charge pump output (CP1) is monitored in order to ensure a correct control of the external MOSFETs.

If CP1 falls below the configured charge pump undervoltage threshold V_{CP1UV} , the device will:

- Discharge the external MOSFETs actively with IDISCHG_ST for the duration TCCP
- Turn-off the gate drivers
- Activate the passive discharge path
- Set and latch CP1UV bit in [STAT1](#)
- Set and latch SUPE bit in [STAT](#) and [Global status byte](#)

Note: The charge pump undervoltage event is ignored during blanking time, and will be reported after filter time as shown in [Figure 11](#).

If [STAT1](#) is cleared when $V_{CP1} > V_{CP1UV}$, the device resets the SUPE bit and resumes normal operation after the charge pump blanking time and the filter time.

Note: CPREC setting bit is ignored for charge pump undervoltage event. It is only related to the VSM undervoltage and VSM overvoltage events.

The voltage of the charge pump output (CP2) is monitored in order to ensure a correct control of the external MOSFETs.

If CP2 falls below the configured charge pump undervoltage threshold V_{CP2UV} , the device will:

- Discharge the external MOSFETs actively with IDISCHG_ST for the duration TCCP
- Turn-off the gate drivers
- Activate the passive turn-off path
- Set and latch CP2UV bit in [STAT1](#)
- Set and latch SUPE bit in [STAT](#) and [Global status byte](#)

Note: The charge pump undervoltage event is ignored during blanking time, and will be reported after filter time as shown in [Figure 11](#).

If [STAT1](#) is cleared when $V_{CP2} > V_{CP2UV}$, after charge pump blanking time and the filter time the device resumes normal operation and resets the SUPE bit.

Note: CPREC setting bit is ignored for the charge pump undervoltage event. It is only related to the VSM undervoltage and VSM overvoltage events.

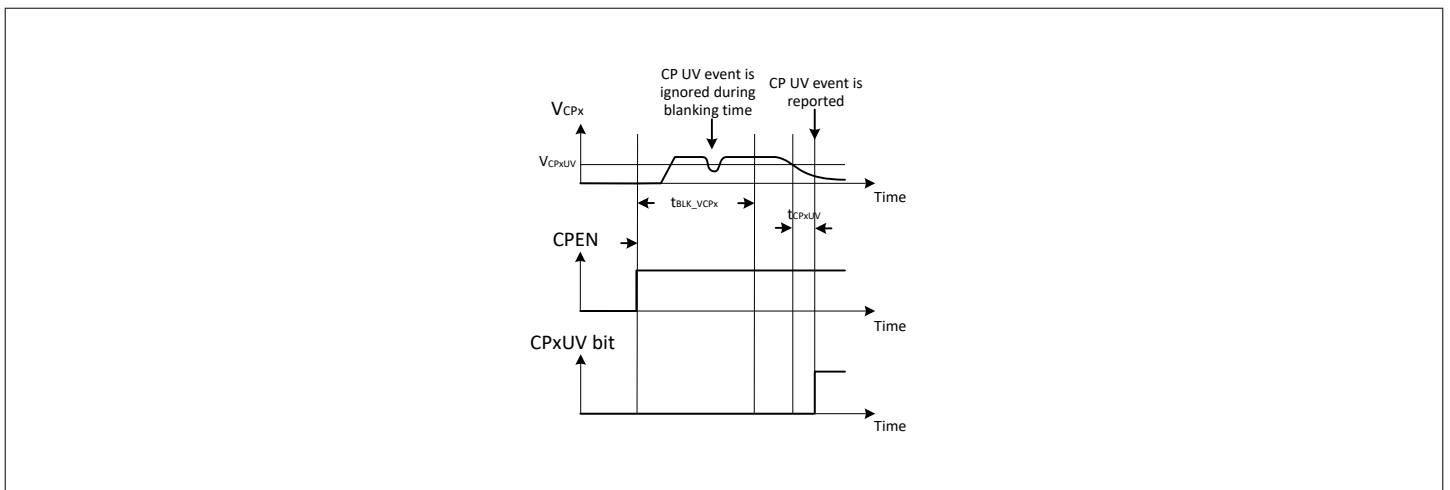

Figure 11 Charge pump undervoltage event

5.9 Electrical characteristics protection and diagnosis

Table 13 Electrical characteristics

$V_{SM} = 8.0\text{ V to }60\text{ V}$, $T_j = -40^\circ\text{C to }+175^\circ\text{C}$, all voltages with respect to ground, positive current flowing into pin (unless otherwise specified)

Parameter	Symbol	Values			Unit	Note or condition	P-Number
		Min.	Typ.	Max.			
Watchdog							
Watchdog period	t_{WDPER}	–	2 4 8 16 64 128 256 512	–	ms	WDPER[2:0] = 000 _B WDPER[2:0] = 001 _B WDPER[2:0] = 010 _B WDPER[2:0] = 011 _B WDPER[2:0] = 100 _B WDPER[2:0] = 101 _B WDPER[2:0] = 110 _B WDPER[2:0] = 111 _B	P_PRO_01_01
Watchdog period accuracy	t_{WDPER_ACC}	-10	–	+10	%	–	P_PRO_01_02
Filter time to avoid false VDS error during recovery from the errors							
Gate driver filter time	t_{GD_filt}	60	72	86	μs	–	P_PRO_01_03
Off-state open load diagnosis							
Pull-up diagnosis current	I_{PUDiag}	-0.9	-2	-3.0	mA	$8\text{ V} \leq \text{HBOUT}_x \leq 60\text{ V}$ $\text{HBOUT}_x = \text{VBAT}$	P_PRO_01_04
Pull-down diagnosis current	I_{PDDiag}	4.5	7	10.5	mA	$8\text{ V} \leq \text{HBOUT}_x \leq 60\text{ V}$ $\text{HBOUT}_x = \text{VBAT}$	P_PRO_01_05
Pull-down pull-up diagnosis current ratio	$IPDDiag / IPUDiag$	2.7	–	–	–	–	P_PRO_01_06
Drain-source monitoring threshold							
Drain-source monitoring threshold	$V_{VDSMONTHx}$	–	0.145 0.195 0.245 0.295 0.39 0.49 0.59 2	–	V	HBxVDSTH[2:0] = 000 _B HBxVDSTH[2:0] = 001 _B HBxVDSTH[2:0] = 010 _B HBxVDSTH[2:0] = 011 _B HBxVDSTH[2:0] = 100 _B HBxVDSTH[2:0] = 101 _B HBxVDSTH[2:0] = 110 _B HBxVDSTH[2:0] = 111 _B	P_PRO_01_07
Drain-source monitoring threshold accuracy low	$V_{VDSMONTH_ACC1}$	-30	–	+30	%	VDSTH[2:0] = 000 _B	P_PRO_01_08

(table continues...)
Datasheet

Table 13 (continued) Electrical characteristics

$V_{SM} = 8.0\text{ V to }60\text{ V}$, $T_j = -40^\circ\text{C to }+175^\circ\text{C}$, all voltages with respect to ground, positive current flowing into pin (unless otherwise specified)

Parameter	Symbol	Values			Unit	Note or condition	P-Number
		Min.	Typ.	Max.			
Drain-source monitoring threshold accuracy high	$V_{VDSMONTH_ACC2}$	-20	-	+20	%	VDSTH[2:0] = 001 _B VDSTH[2:0] = 010 _B VDSTH[2:0] = 011 _B VDSTH[2:0] = 100 _B VDSTH[2:0] = 101 _B VDSTH[2:0] = 110 _B VDSTH[2:0] = 111 _B	P_PRO_01_09

Drain-source monitoring filter time

VDS monitoring filter time	t_{DSMON_FILT}	-	0.25 0.50 0.75 1.00 1.25 1.50 1.75 2.00	-	μs	TFVDS[2:0] = 000 _B TFVDS[2:0] = 001 _B TFVDS[2:0] = 010 _B TFVDS[2:0] = 011 _B TFVDS[2:0] = 100 _B TFVDS[2:0] = 101 _B TFVDS[2:0] = 110 _B TFVDS[2:0] = 111 _B	P_PRO_01_10
VDS monitoring filter time accuracy	$t_{DSMONFILT_ACC}$	-10	-	+10	%	-	P_PRO_01_11

Drain-source monitoring blank time

Drain-source monitoring blank time	t_{DSMON_BLK}	-	0.5 1.0 1.5 2.0 2.5 3.0 3.5 4.0	-	μs	TBLK[2:0] = 000 _B TBLK[2:0] = 001 _B TBLK[2:0] = 010 _B TBLK[2:0] = 011 _B TBLK[2:0] = 100 _B TBLK[2:0] = 101 _B TBLK[2:0] = 110 _B TBLK[2:0] = 111 _B	P_PRO_01_12
Drain-source monitoring blank time accuracy	$t_{DSMONBLK_ACC}$	-10	-	+10	%	-	P_PRO_01_13

(table continues...)

Table 13 (continued) Electrical characteristics

$V_{SM} = 8.0\text{ V to }60\text{ V}$, $T_j = -40^\circ\text{C to }+175^\circ\text{C}$, all voltages with respect to ground, positive current flowing into pin (unless otherwise specified)

Parameter	Symbol	Values			Unit	Note or condition	P-Number
		Min.	Typ.	Max.			
Cross current protection							
Cross current protection time	$t_{HBxCCPx}$	–	0.5 1.0 1.5 2.0 2.5 3.0 3.5 4.0	–	μs	TCCP[2:0] = 000 _B TCCP[2:0] = 001 _B TCCP[2:0] = 010 _B TCCP[2:0] = 011 _B TCCP[2:0] = 100 _B TCCP[2:0] = 101 _B TCCP[2:0] = 110 _B TCCP[2:0] = 111 _B	P_PRO_01_14
Cross current protection time accuracy	$t_{HBxCCPx_ACC}$	-10	–	+10	%	–	P_PRO_01_15
Thermal warning and shutdown							
Thermal warning junction temperature	T_{jW}	156	170	185	$^\circ\text{C}$	–	P_PRO_01_16
Thermal shutdown junction temperature	T_{jSD}	196	210	225	$^\circ\text{C}$	–	P_PRO_01_17
Thermal shutdown hysteresis	T_{jHYS}	5	10	–	$^\circ\text{C}$	–	P_PRO_01_18

6 Gate driver

6.1 Gate driver control

The device integrates six floating gate drivers capable of controlling a wide range of N-channel MOSFETs. They are configured as three high-sides and three low-sides, building for 3-phase BLDC.

The MOSFETs can be:

- Deactivated with `BD_EN = 0`
- Activated in PWM mode with `BD_EN = 1` and `CPEN = 1`

The MOSFETs are controlled as shown in [Figure 12](#), [Figure 13](#), [Figure 14](#) and [Figure 15](#).

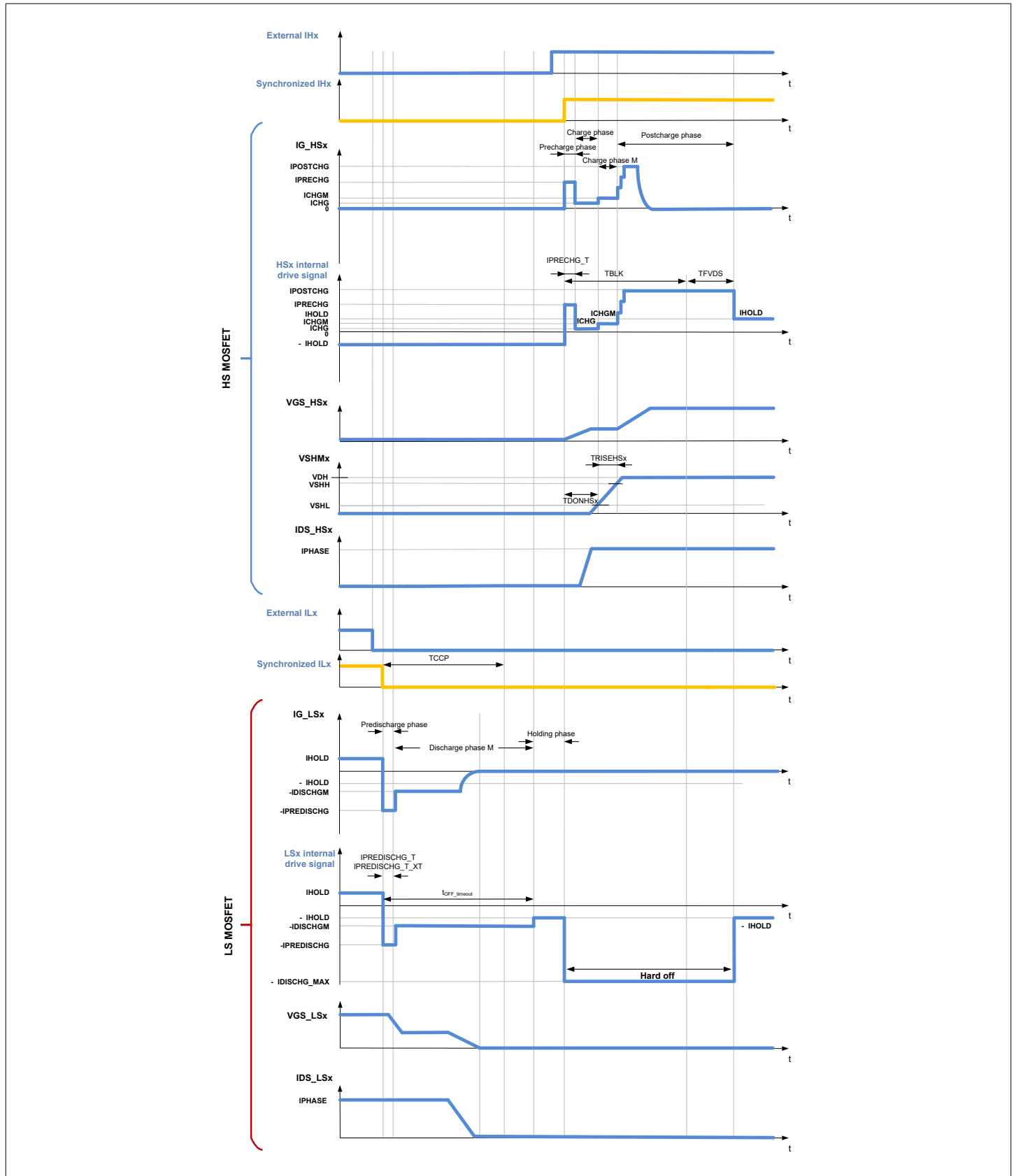

Figure 12 Turn-on of the high-side MOSFET

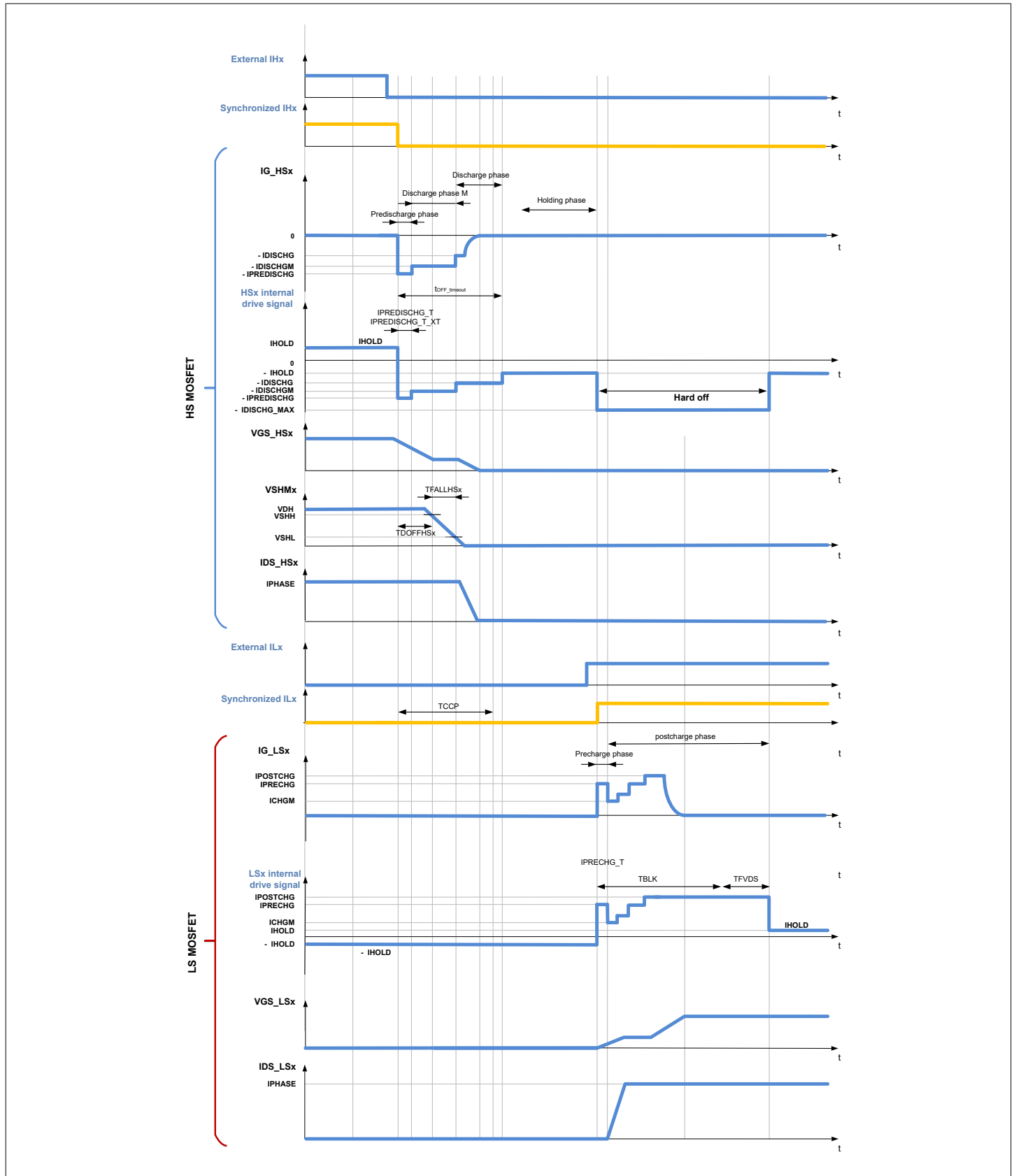

Figure 13 Turn-off of the high-side MOSFET

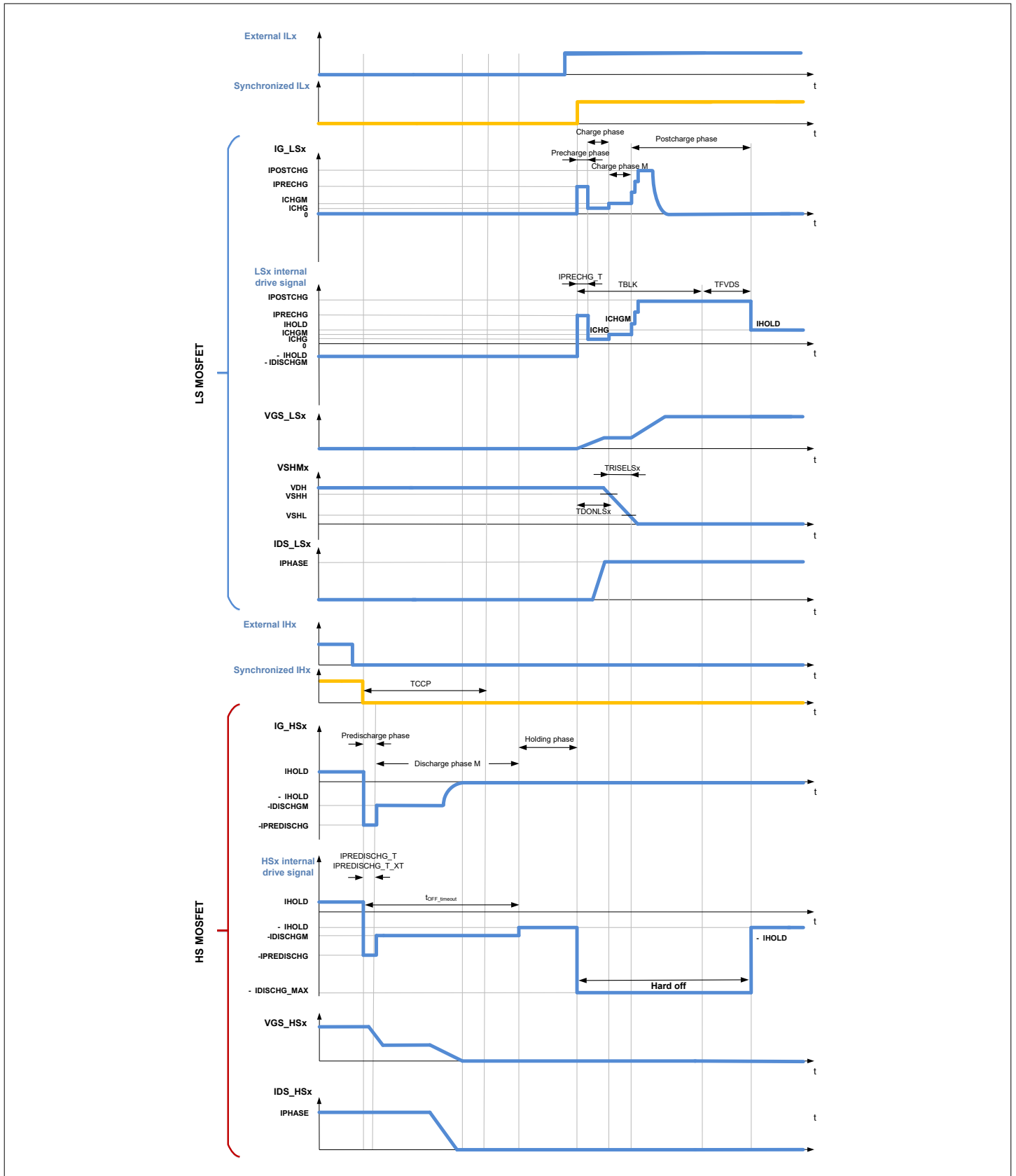

Figure 14 Turn-on of the low-side MOSFET

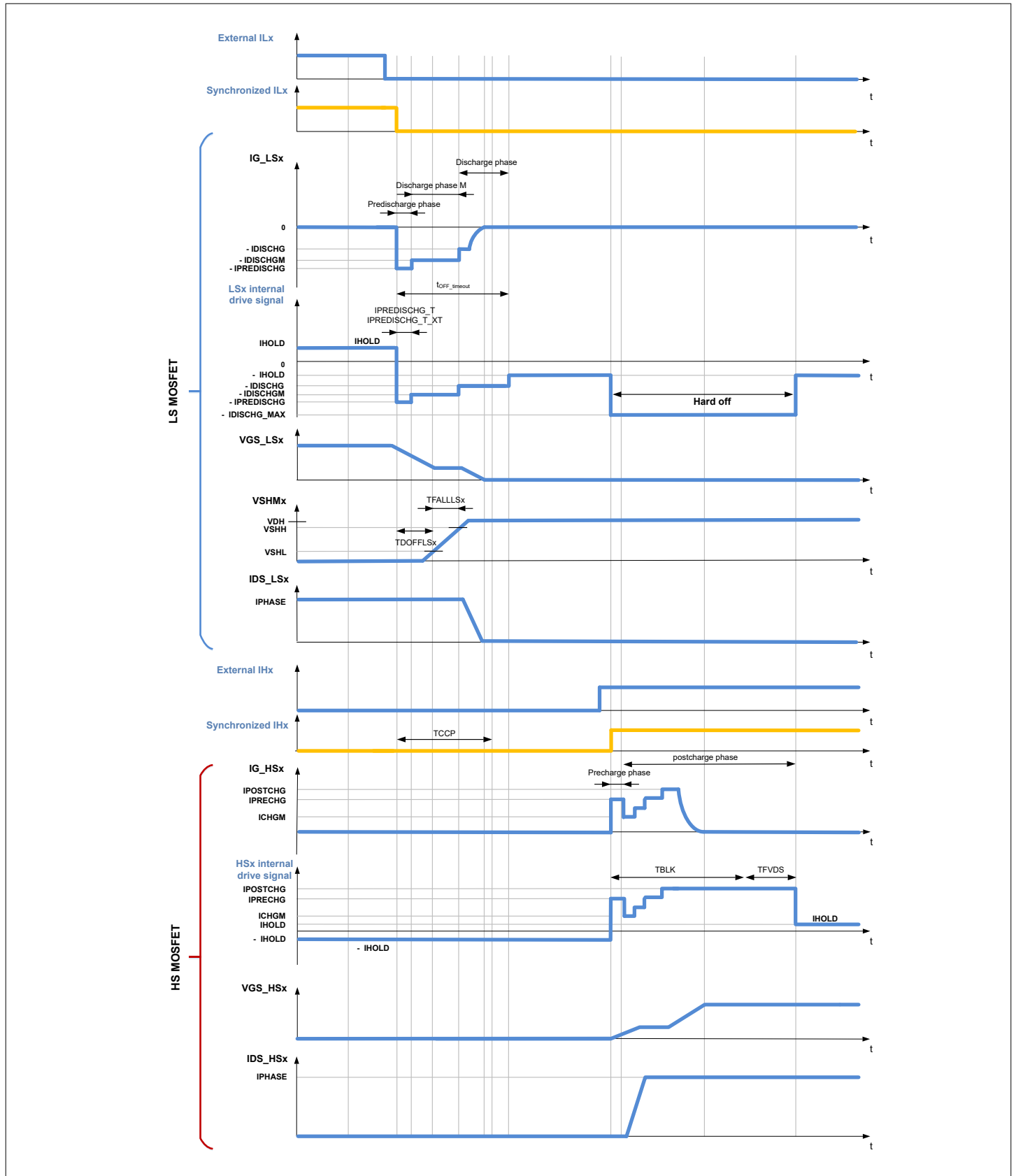

Figure 15 Turn-off of the low-side MOSFET

The turn-on of the high-side MOSFET is done in five phases (refer to [Figure 12](#)):

- 1. Cross-current protection phase:** the cross-current protection time TCCP starts at the falling edge of ILx. During TCCP, the low-side MOSFET is turned off while the high-side is kept off with IHOLD. Only after TCCP IHx is allowed to set to high. The low-side will be kept off with hard off current until TFVDS has elapsed
- 2. Pre-charge phase:** once the TCCP has elapsed and IHx is set to high, the gate of the high-side MOSFET is pre-charged with the current IPRECHG for a duration IPRECHG_T. When IPRECHG_T expires it will jump to charge phase
- 3. Charge phase:** after the pre-charge phase the charge current is decreased from IPRECHG down to ICHG. The gate of the high-side MOSFET will be charged with ICHG until VSHMx reaches GND + 2 V. If VSHMx reaches VDH - 2 V during the charge phase, it will jump to post-charge phase
- 4. Middle-charge phase:** after the charge phase the gate of the high-side MOSFET will be charged with ICHGM until VSHMx reaches VDH - 2 V
- 5. Post-charge phase:** after the middle-charge phase the control signal for the charge current is set to IPOSTCHG until the end of TFVDS. If the device is still in the ramping phase of the post-charge current when TFVDS has expired, the ramp phase will be extended until it reaches IPOSTCHG. After TFVDS expires and IPOSTCHG is reached, the charge current will be switched to IHOLD

Cross-current protection time TCCP represents the time after which the complementary transistor in the same half-bridge can be activated. Therefore TCCP is the minimum discharge phase for the MOSFET. $t_{OFF_timeout}$ is the maximum time for discharge.

The turn-off of the high-side MOSFET is done in four phases (refer to [Figure 13](#)):

- 1. Pre-discharge phase:** once IHx is set to low, the gate of the high-side MOSFET is pre-discharged with the current IPREDISCHG for a duration based on IPREDISCHG_T and IPREDISCHG_T_XT. It will jump to middle-discharge phase after pre-discharge time expires
- 2. Middle-discharge phase:** after the pre-discharge phase the gate current is decreased from IPREDISCHG down to IDISCHGM. The gate of the high-side MOSFET will be discharged with IDISCHGM until VSHMx reaches GND + 2 V
- 3. Discharge phase:** after the middle-discharge phase the device will enter discharge phase. The gate of the high-side MOSFET will be discharged with IDISCHG until $t_{OFF_timeout}$ expires
- 4. Holding phase:** after the $t_{OFF_timeout}$ expires the high-side MOSFET will be kept off with IHOLD

Note: If a INE failure comes, all MOSFETs will be discharged with IDISCHG_ST for a duration of TCCP.

The turn-on of the low-side MOSFET is done in five phases (refer to [Figure 14](#)):

- 1. Cross-current protection phase:** the cross-current protection time TCCP starts at the falling edge of IHx. During TCCP, the high-side MOSFET is turned off while the low-side is kept off with IHOLD. Only after TCCP ILx is allowed to set to high. The high-side will be kept off with hard off current until TFVDS has elapsed
- 2. Pre-charge phase:** once the TCCP has elapsed and ILx is set to high, the gate of the low-side MOSFET is pre-charged with the current IPRECHG for a duration IPRECHG_T. After IPRECHG_T expires, it will jump to charge phase
- 3. Charge phase:** after the pre-charge phase the charge current is decreased from IPRECHG down to ICHG. The gate of the low-side MOSFET will be charged with ICHG until VSHMx reaches VDH - 2 V
- 4. Middle-charge phase:** after the charge phase the gate of the low-side MOSFET will be charged with ICHGM until VSHx reaches GND + 2V
- 5. Post-charge phase:** after the middle-charge phase the control signal for the charge current is set to IPOSTCHG until the end of TFVDS. If the device is still in the ramping phase of the post-charge current when TFVDS has expired, the ramp phase will be extended until it reaches IPOSTCHG. After TFVDS expires and IPOSTCHG is reached, the charge current will be switched to IHOLD

Cross-current protection time TCCP represents the time after which the complementary transistor in the same half-bridge can be activated. Therefore TCCP is the minimum discharge phase for the MOSFET. $t_{OFF_timeout}$ is the maximum time for discharge.

The turn-off of the low-side MOSFET is done in four phases (refer to [Figure 15](#)):

- 1. Pre-discharge phase:** once ILx is set to low, the gate of the low-side MOSFET is pre-discharged with the current IPREDISCHG for a duration based on IPREDISCHG_T and IPREDISCHG_T_XT. It will jump to middle-discharge phase after pre-discharge time expires

- Middle-discharge phase:** after the pre-discharge phase the discharge current is decreased from IPREDISCHG down to IDISCHGM. The gate of the low-side MOSFET will be discharged with IDISCHGM until VSHMx reaches $VDH - 2 V$
- Discharge phase:** after the middle-discharge phase the gate of the low-side MOSFET will be discharged with IDISCHG until $t_{OFF_timeout}$ expires
- Holding phase:** after the $t_{OFF_timeout}$ expires the high-side MOSFET will be kept off with IHOLD

Note: If a INE failure comes, all MOSFETs will be discharged with IDISCHG_ST for a duration of TCCP.

High-side MOSFET:

- TDONHSx is counted from the rising edge of the synchronized IHx until VSHMx reaches $GND + 2 V$
- TRISEHSx is counted from the VSHMx reaching $GND + 2 V$ until it reaches $VDH - 2 V$
- If VSHMx does not reach $GND + 2 V$ until TBLK is elapsed, 0xFF and 0x00 will be saved in effective high-side MOSFET turn-on delay register and effective high-side MOSFET rise time register respectively
- If VSHMx has reached $VDH - 2 V$ when the rising edge of the synchronized IHx comes, 0x00 will be stored in both the effective high-side MOSFET turn-on delay register and the effective high-side MOSFET rise time register
- If VSHMx reaches $GND + 2 V$ but does not reach $VDH - 2 V$ when TBLK is elapsed, 0xFF will be saved in the effective high-side MOSFET rise time register
- TDOFFHSx is counted from the falling edge of the synchronized IHx until VSHMx reaches $VDH - 2 V$
- TFALLHSx is counted from the VSHMx reaching $VDH - 2 V$ until it reaches to $GND + 2 V$
- If VSHMx does not reach $VDH - 2 V$ until TCCP is elapsed, 0xFF and 0x00 will be saved in effective high-side MOSFET turn-off delay register and effective high-side MOSFET fall time register respectively
- If VSHMx has reached $GND + 2 V$ when the falling edge of the synchronized IHx comes, 0x00 will be stored in both the effective high-side MOSFET turn-off delay register and the effective high-side MOSFET fall time register
- If VSHMx reaches $VDH - 2 V$ but does not reach $GND + 2 V$ when TCCP is elapsed, 0xFF will be saved in the effective high-side MOSFET fall time register

Note:

- If $VDH - 2 V > VSHMx > GND + 2 V$ when the rising edge of the synchronized IHx comes, 0x00 will be saved in effective high-side MOSFET turn-on delay register and the time from the IHx rising edge to VSHMx reaching $VDH - 2 V$ will be saved in the effective high-side MOSFET rise time register
- If 0x00 is saved as the turn-on delay time, the rise time TRISEHSx might not reflect the slew rate correctly. It is not recommended to use the TRISEHSx to adjust the switching behavior
- If IHx pulse is shorter than TBLK/TCCP, the registers will keep the last value and will not be updated

Low-side MOSFET:

- TDONLSx is counted from the rising edge of the synchronized ILx until VSHMx reaches $VDH - 2 V$
- TRISELSx is counted from the VSHMx reaching $VDH - 2 V$ until it reaches $GND + 2 V$
- If VSHMx does not reach $VDH - 2 V$ until TBLK is elapsed, 0xFF and 0x00 will be saved in effective low-side MOSFET turn-on delay register and effective low-side MOSFET rise time register respectively
- If VSHMx has reached $GND + 2 V$ when the rising edge of the synchronized ILx comes, 0x00 will be stored in both the effective low-side MOSFET turn-on delay register and the effective low-side MOSFET rise time register
- If VSHMx reaches $VDH - 2 V$ but does not reach $GND + 2 V$ when TBLK is elapsed, 0xFF will be saved in the effective low-side MOSFET rise time register
- TDOFFLSx is counted from the falling edge of the synchronized ILx until VSH reaches $GND + 2 V$
- TFALLLSx is counted from the VSHMx reaching $GND + 2 V$ until it reaches to $VDH - 2 V$
- If VSHMx does not reach $GND + 2 V$ until TCCP is elapsed, and 0xFF and 0x00 will be saved in effective low-side MOSFET turn-off delay register and effective low-side MOSFET fall time register respectively
- If VSHMx has reached $VDH - 2 V$ when the falling edge of the synchronized ILx comes, 0x00 will be stored in both the effective low-side MOSFET turn-off delay register and the effective low-side MOSFET fall time register
- If VSHMx reaches $GND + 2 V$ but does not reach $VDH - 2 V$ when TCCP is elapsed, 0xFF will be saved in the effective low-side MOSFET fall time register

Note:

- If $V_{DH} - 2V > V_{SHMx} > GND + 2V$ when the rising edge of the synchronized ILx comes, $0x00$ will be saved in effective low-side MOSFET turn-on delay register and the time from the ILx rising edge to V_{SHMx} reaching $GND + 2V$ will be saved in the effective low-side MOSFET rise time register
- If $0x00$ is saved as the turn-on delay time, the rise time $TRISELSx$ might not reflect the slew rate correctly. It is not recommended to use the $TRISELSx$ to adjust the switching behavior
- The values in the registers are invalid if I_{Hx}/ILx pulse is active shorter than $TBLK$ or inactive shorter than $TCCP$

6.2 Electrical characteristics of gate driver

Table 14 Electrical characteristics gate driver

$V_{SM} = 8.0\text{ V to }60\text{ V}$, $T_j = -40^\circ\text{C to }+175^\circ\text{C}$, all voltages with respect to ground, positive current flowing into pin (unless otherwise specified)

Parameter	Symbol	Values			Unit	Note or condition	P-Number
		Min.	Typ.	Max.			
High input voltage threshold of ILx , I_{Hx} ($V_{DD} = 5\text{ V}$)	V_{IH1_IN}	2.5	–	–	V	$V_{DD} = 5\text{ V}$	P_BDRV_01_01
High input voltage threshold of ILx , I_{Hx} ($V_{DD} = 3.3\text{ V}$)	V_{IH2_IN}	1.5	–	–	V	$V_{DD} = 3.3\text{ V}$	P_BDRV_01_02
Low input voltage threshold of ILx , I_{Hx} ($V_{DD} = 5\text{ V}$)	V_{IL1_IN}	–	–	0.8	V	$V_{DD} = 5\text{ V}$	P_BDRV_01_03
Low input voltage threshold of ILx , I_{Hx} ($V_{DD} = 3.3\text{ V}$)	V_{IL2_IN}	–	–	0.6	V	$V_{DD} = 3.3\text{ V}$	P_BDRV_01_04
Hysteresis of ILx , I_{Hx} ($V_{DD} = 5\text{ V}$)	V_{IHY1_IN}	100	400	–	mV	$V_{DD} = 5\text{ V}$	P_BDRV_01_05
Hysteresis of ILx , I_{Hx} ($V_{DD} = 3.3\text{ V}$)	V_{IHY2_IN}	100	150	–	mV	$V_{DD} = 3.3\text{ V}$	P_BDRV_01_06
Maximum total charge driver capability	Q_{tot_max}	–	–	1400	nC	Due to charge pump current capability only $6 * \text{MOSFETs} + \text{additional external capacitors with a total charge of max. } 1400\text{ nC}$ can be driven simultaneous at a PWM frequency of 25 kHz .	P_BDRV_01_07
High level output voltage low: G_{HMx} vs. S_{HMx}	V_{GSHMx}	6.5	–	12.5	V	$V_{SM} = 8\text{ V}$, $I_{CP1} = 5.6\text{ mA}$, $I_{CP2} = 5.6\text{ mA}$, $CPEN = 1b$, $BD_EN = 1b$	P_BDRV_01_08
High level output voltage high: G_{HMx} vs. S_{HMx}	V_{GSHMx}	10	11	12.5	V	$V_{SM} > 13\text{ V}$, $I_{CP1} = 19.1\text{ mA}$, $I_{CP2} = 19.1\text{ mA}$, $CPEN = 1b$, $BD_EN = 1b$	P_BDRV_01_09

(table continues...)

Table 14 (continued) Electrical characteristics gate driver

$V_{SM} = 8.0\text{ V to }60\text{ V}$, $T_j = -40^\circ\text{C to }+175^\circ\text{C}$, all voltages with respect to ground, positive current flowing into pin (unless otherwise specified)

Parameter	Symbol	Values			Unit	Note or condition	P-Number
		Min.	Typ.	Max.			
High level output voltage low: GLMx vs. SLMx	V_{GSLMx}	8	–	12.5V	V	$V_{SM} = 8\text{ V}$, $I_{CP1} = 5.6\text{ mA}$, $I_{CP2} = 5.6\text{ mA}$, $CPEN = 1b$, $BD_EN = 1b$	P_BDRV_01_10
High level output voltage high: GLMx vs. SLMx	V_{GSLMx}	10	11	12.5	V	$V_{SM} > 13\text{ V}$, $I_{CP1} = 19.1\text{ mA}$, $I_{CP2} = 19.1\text{ mA}$, $CPEN = 1b$, $BD_EN = 1b$	P_BDRV_01_11
Gate driver current turn-on rise time	$t_{GDRV_RISE(ON)}$	20	75	120	ns	From 20% of ICHG to 80% of ICHG, $x = 0\text{ to }63$, $C_{Load} = 20\text{ nF}$	P_BDRV_01_12
Gate driver current turn-off rise time	$t_{GDRV_RISE(OFF)}$	20	75	120	ns	From 20% of IDISCHG to 80% of IDISCHG, $x = 0\text{ to }63$, $C_{Load} = 20\text{ nF}$	P_BDRV_01_13
HS delay on time low	$t_{delay_on(HS)}$	220	280	360	ns	$HBFREQ = 0_B$ From IHx reaching high voltage threshold to 20% of ICHGx, $x = 0\text{ to }63$	P_BDRV_01_14
HS delay on time high	$t_{delay_on(HS)}$	250	320	400	ns	$HBFREQ = 1_B$ From IHx reaching high voltage threshold to 20% of ICHGx, $x = 0\text{ to }63$	P_BDRV_01_15
HS delay off time low	$t_{delay_off(HS)}$	220	280	360	ns	$HBFREQ = 0_B$ From IHx reaching low voltage threshold to 20% of IDISCHGx, $x = 0\text{ to }63$	P_BDRV_01_16
HS delay off time high	$t_{delay_off(HS)}$	250	320	400	ns	$HBFREQ = 1_B$ From IHx reaching low voltage threshold to 20% of IDISCHGx, $x = 0\text{ to }63$	P_BDRV_01_17
LS delay on time low	$t_{delay_on(LS)}$	220	280	360	ns	$HBFREQ = 0_B$ From ILx reaching high voltage threshold to 20% of ICHGx, $x = 0\text{ to }63$	P_BDRV_01_18

(table continues...)

Table 14 (continued) Electrical characteristics gate driver

$V_{SM} = 8.0\text{ V to }60\text{ V}$, $T_j = -40^\circ\text{C to }+175^\circ\text{C}$, all voltages with respect to ground, positive current flowing into pin (unless otherwise specified)

Parameter	Symbol	Values			Unit	Note or condition	P-Number
		Min.	Typ.	Max.			
LS delay on time high	$t_{\text{delay_on(LS)}}$	250	320	400	ns	HBFREQ = 1 _B From ILx reaching high voltage threshold to 20% of ICHG _x , x = 0 to 63	P_BDRV_01_19
LS delay off time low	$t_{\text{delay_off(LSx)}}$	220	280	360	ns	HBFREQ = 0 _B From ILx reaching low voltage threshold to 20% of IDISCHG _x , x = 0 to 63	P_BDRV_01_20
LS delay off time high	$t_{\text{delay_off(LSx)}}$	250	320	400	ns	HBFREQ = 1 _B From ILx reaching low voltage threshold to 20% of IDISCHG _x , x = 0 to 63	P_BDRV_01_21
Charge/discharge current accuracy (00 0000B)	I_{ACC0}	-60	–	+75	%	ICHG / IDISCHG / IPRECHG / IPREDISCHG / IPOSTCHG / ICHGM / IDISCHGM = 00 0000 _B	P_BDRV_01_22
Charge/discharge current accuracy (00 1111B)	I_{ACC15}	-40	–	+40	%	ICHG / IDISCHG / IPRECHG / IPREDISCHG / IPOSTCHG / ICHGM / IDISCHGM = 00 1111 _B	P_BDRV_01_23
Charge/discharge current accuracy (01 1111B)	I_{ACC31}	-30	–	+30	%	ICHG / IDISCHG / IPRECHG / IPREDISCHG / IPOSTCHG / ICHGM / IDISCHGM = 01 1111 _B	P_BDRV_01_24
Charge/discharge current accuracy (10 1111B)	I_{ACC31}	-20	–	+20	%	ICHG / IDISCHG / IPRECHG / IPREDISCHG / IPOSTCHG / ICHGM / IDISCHGM = 10 1111 _B , IG _x _SEL = 0 _B	P_BDRV_01_25

(table continues...)

Table 14 (continued) Electrical characteristics gate driver

$V_{SM} = 8.0\text{ V to }60\text{ V}$, $T_j = -40^\circ\text{C to }+175^\circ\text{C}$, all voltages with respect to ground, positive current flowing into pin (unless otherwise specified)

Parameter	Symbol	Values			Unit	Note or condition	P-Number
		Min.	Typ.	Max.			
Charge/discharge current accuracy (10 1111B)	I_{ACC31_H}	-25	-	+25	%	ICHG / IDISCHG / IPRECHG / IPREDISCHG / IPOSTCHG / ICHGM / IDISCHGM = 10 1111 _B , IGx_SEL = 1 _B	P_BDRV_01_43
Charge/discharge current accuracy (11 1111B)	I_{ACC63}	-20	-	+20	%	ICHG / IDISCHG / IPRECHG / IPREDISCHG / IPOSTCHG / ICHGM / IDISCHGM = 11 1111 _B , IGx_SEL = 0 _B	P_BDRV_01_26
Charge/discharge current accuracy (11 1111B)	I_{ACC63_H}	-25	-	+25	%	ICHG / IDISCHG / IPRECHG / IPREDISCHG / IPOSTCHG / ICHGM / IDISCHGM = 11 1111 _B , IGx_SEL = 1 _B	P_BDRV_01_44
Discharge_ST current accuracy (0 0000B)	I_{ACC_ST0}	-60	-	+75	%	IDISCHG_ST = 0 0000 _B	P_BDRV_01_27
Discharge_ST current accuracy (0 0111B)	I_{ACC_ST7}	-40	-	+40	%	IDISCHG_ST = 0 0111 _B	P_BDRV_01_28
Discharge_ST current accuracy (0 1111B)	I_{ACC_ST15}	-30	-	+30	%	IDISCHG_ST = 0 1111 _B	P_BDRV_01_29
Discharge_ST current accuracy (1 0111B)	I_{ACC_ST23}	-20	-	+20	%	IDISCHG_ST = 1 0111 _B , IGx_SEL = 0 _B	P_BDRV_01_30
Discharge_ST current accuracy (1 0111B)	$I_{ACC_ST23_H}$	-25	-	+25	%	IDISCHG_ST = 1 0111 _B , IGx_SEL = 1 _B	P_BDRV_01_45
Discharge_ST current accuracy (1 1111B)	I_{ACC_ST31}	-20	-	+20	%	IDISCHG_ST = 1 1111 _B , IGx_SEL = 0 _B	P_BDRV_01_31
Discharge_ST current accuracy (1 1111B)	$I_{ACC_ST31_H}$	-25	-	+25	%	IDISCHG_ST = 1 1111 _B , IGx_SEL = 1 _B	P_BDRV_01_46

(table continues...)

Table 14 (continued) Electrical characteristics gate driver

$V_{SM} = 8.0\text{ V to }60\text{ V}$, $T_j = -40^\circ\text{C to }+175^\circ\text{C}$, all voltages with respect to ground, positive current flowing into pin (unless otherwise specified)

Parameter	Symbol	Values			Unit	Note or condition	P-Number
		Min.	Typ.	Max.			
SHMx comparator delay	t_{SHMx}	–	5	40	ns	–	P_BDRV_01_35
Discharge timeout	$t_{OFF_timeout}$	3.2	4	4.8	μs	–	P_BDRV_01_32
SHMx High Threshold	V_{SHMH}	$V_{DH} - 3.0$	–	$V_{DH} - 2.0$	V	–	P_BDRV_01_33
SHMx Low Threshold	V_{SHL}	2	–	3.0	V	Referred to GND	P_BDRV_01_34
On resistance of gate current source	R_{ONGX}	2	–	11	Ω	–	P_BDRV_01_36
BEMF comparator accuracy	V_{BEMF_ACC}	-100	–	+100	mV	$V_{SM} = 48\text{V}$	P_BDRV_01_37
BEMF hysteresis	V_{BEMF_HYS}	–	100	–	mV	–	P_BDRV_01_38

7 BEMF comparator

The device has 3 BEMF comparators integrated. GEF can be configured to show the output of each BEMF comparator and sent back via SDO as shown in Figure 16 below.

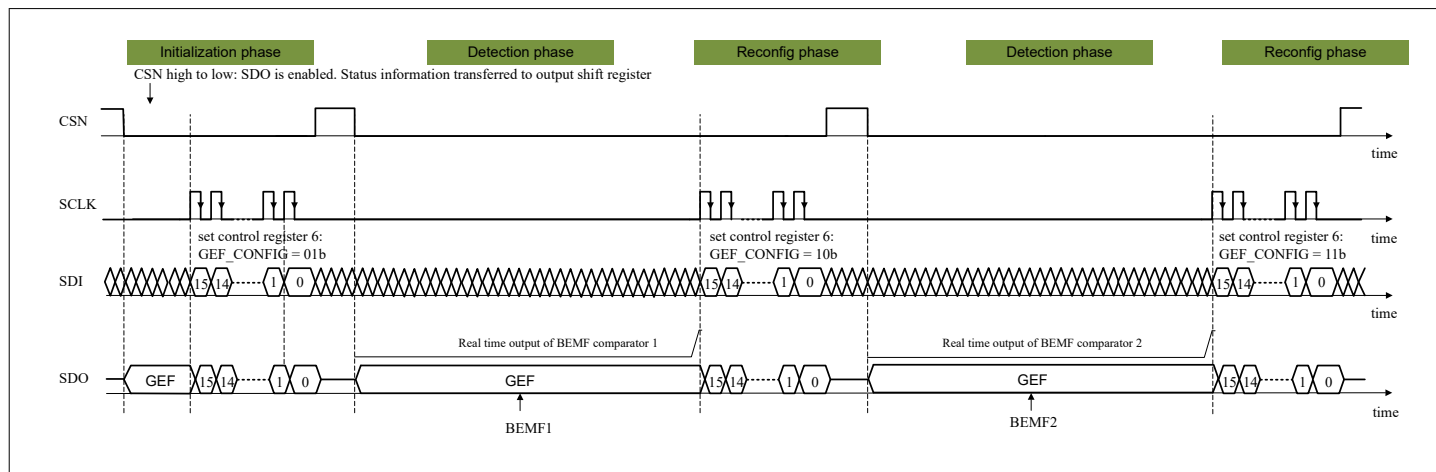

Figure 16 BEMF signal is sent back via SDO

When BEMF_POCESSING_EN bit is set to 0_B, the real time signal of the outputs of the BEMF comparators can be read from STAT4:

If the voltage at SHM_x is higher than the average voltage of the other two SHM pins $(SHM_y + SHM_z) / 2$, the output of the corresponding BEMF comparator will be set to 1, and the corresponding bit in the status register will be set to 1. If the voltage at SHM_x is lower than the average voltage of the other two SHM pins $(SHM_y + SHM_z) / 2$, the output of the corresponding BEMF comparator will be set to 0, and the corresponding bit in the status register will be set to 0.

If the BEMF_POCESSING_EN bit is set to 1_B, the BEMF signal read from STAT4 will be the output signal with the post-processing algorithm.

8 Serial Peripheral Interface - SPI

8.1 SPI description

The control input word is read via the data input SDI, which is synchronized with the clock input SCLK provided by the general microcontroller or the **MOTIX™ MCU**. The output word appears synchronously at the data output SDO, see [Figure 17](#).

The transmission cycle begins when the chip is selected by the input CSN (chip select not), low active. After the CSN input returns from low to high, the word that has been read is interpreted according to the content. The SDO output switches to tristate status (high impedance) at this point, thereby releasing the SDO bus for other use. The state of SDI is shifted into the input register with every falling edge on SCLK. The state of SDO is shifted out of the output register after every rising edge on SCLK. The SPI of the device is not daisy chain capable.

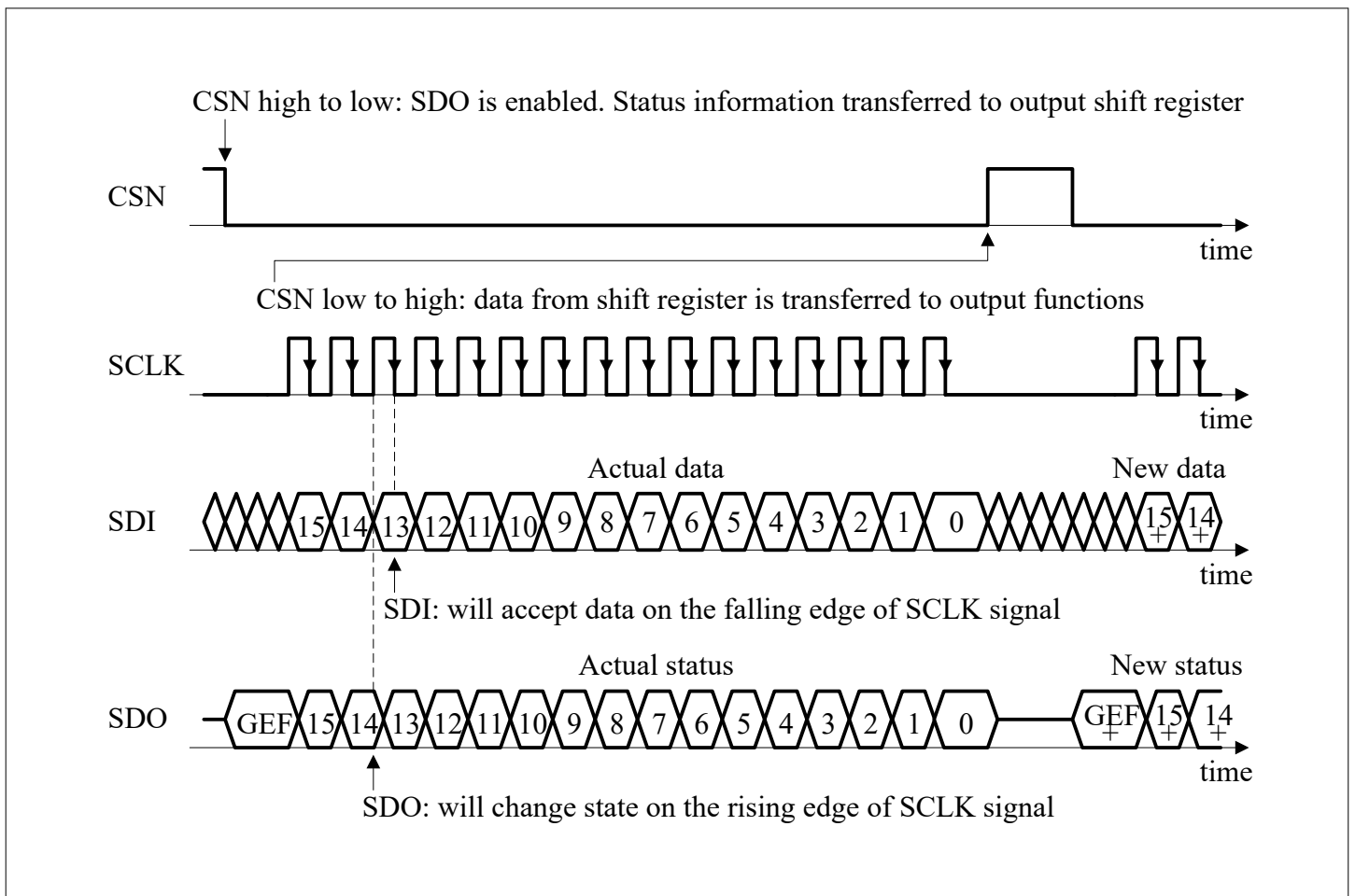

Figure 17 SPI data transfer timing

A SPI communication consists of 16-bit frames:

- SDI receives one address byte followed by one data byte
- SDO transmits the **Global error flag** and the **Global status byte** followed by one response byte

The address byte specifies (see [Figure 18](#)):

- The target register (A[6:0])
- The type of operation:
 - For control registers:
 - Read only: OP bit = 0
 - Read and write: OP bit = 1
 - For status registers:
 - Read only: OP bit = 0
 - Read and clear: OP bit = 1

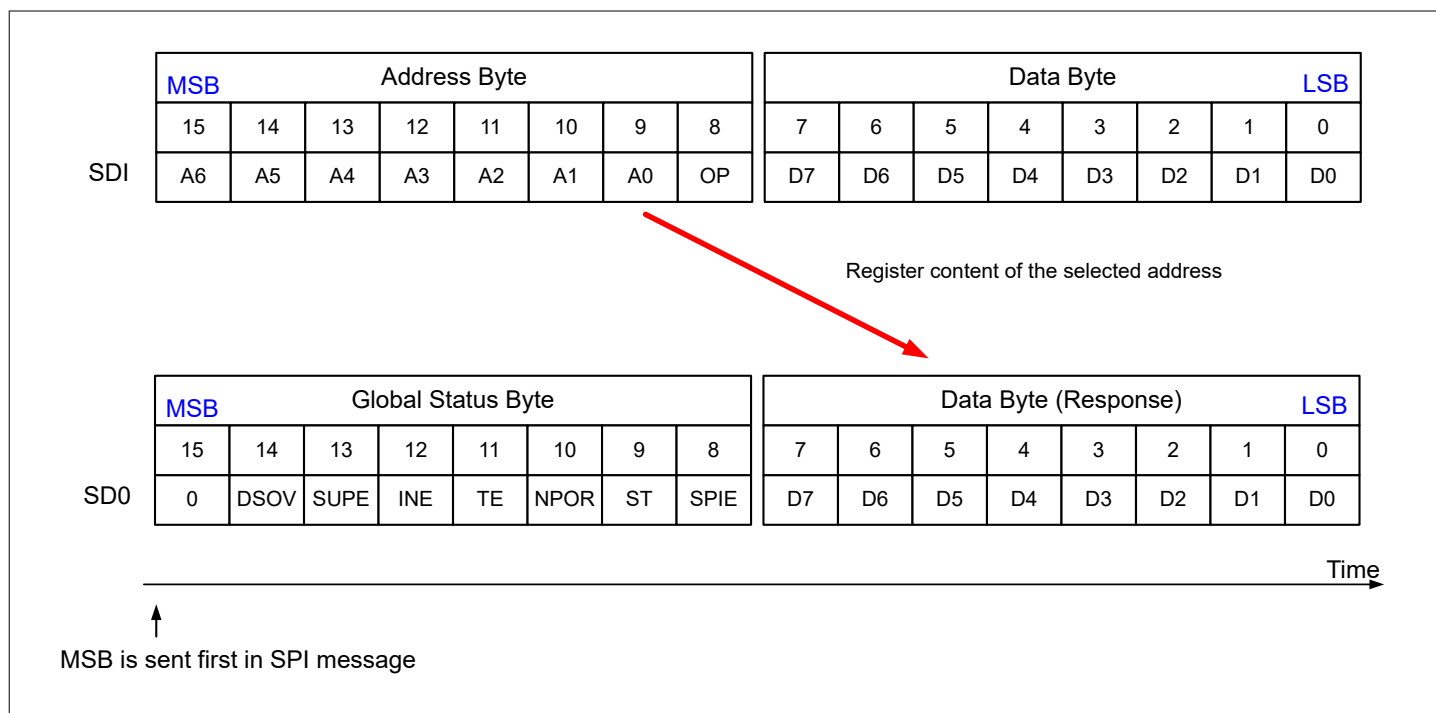

Figure 18 In-frame response

8.2 Global error flag

GEF bit can be configured by GEF_CONFIG in [GENTRL6](#):

- 00_B global error flag
- 01_B back EMF1
- 10_B back EMF2
- 11_B back EMF3

The global error flag (GEF) bit is reported on SDO between the CSN falling edge and the first SCLK rising edge.

When the GEF bit is configured as a global error flag, the device is possible to have a quick diagnostic without any SPI clock pulse in following conditions:

- A fault condition is detected as in [Table 15](#)
- The device comes from a power-on-reset

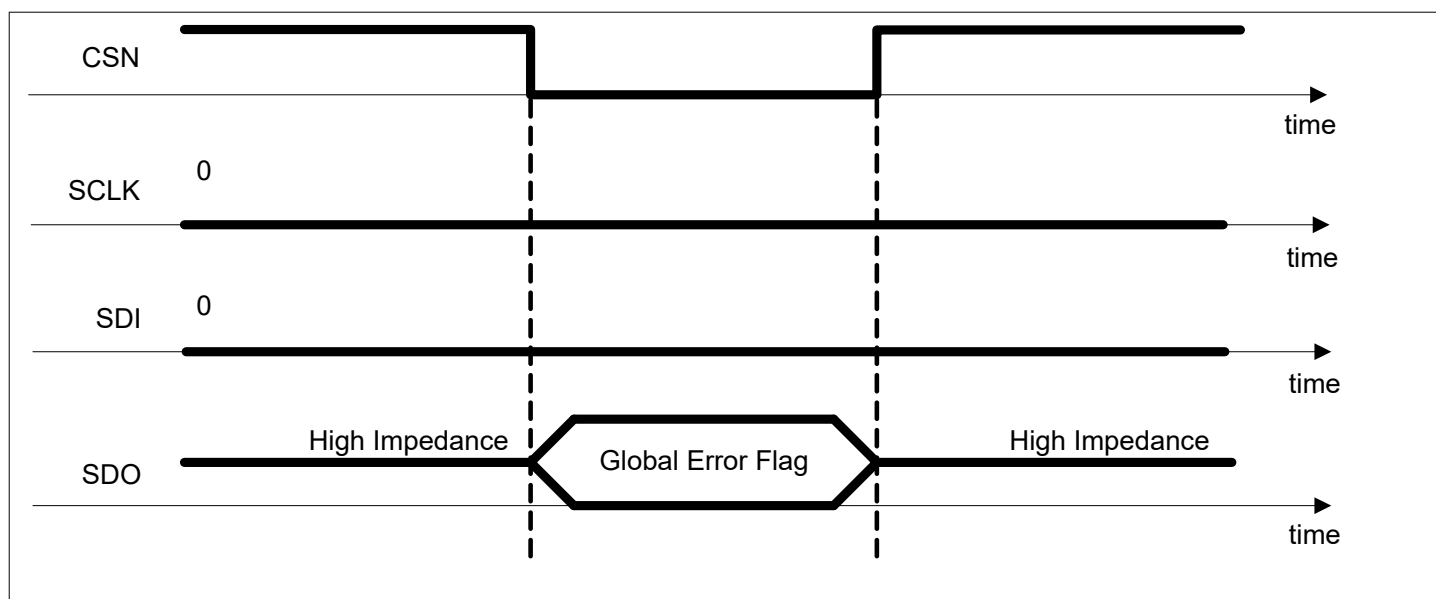

Figure 19 GEF - diagnostic with 0 - clock cycle

8.3 Global status byte

The SDO shifts out the general status register during the first eight SCLK cycles to provide an overview of the device status shown in Table 15 as following (in Figure 18):

- VDS monitoring error (DSOV bit): logical OR combination between HSxDISOV and LSxDISOV
- Supply error (SUPE bit): logical OR combination between VSM undervoltage shutdown (VSMUV), VSM overvoltage shutdown (VSMOV and VSMOV_PROT) and charge pump (CP1UV and CP2UV)
- Input error (INE bit): logical OR combination of INEx bits
- Temperature error (TE bit):
 - Logical OR combination between thermal warning (TW) and thermal shutdown (TSD) when TWDIS = 0
 - Thermal shutdown (TSD) when TSD = 1
- Negated power-on-reset (nPOR bit)
- Stop mode (ST bit)
- SPI protocol error (SPIE bit)

Note: The **Global error flag** is a logic OR combination of every bit of the global status byte: $GEF = (DSOV) OR (SUPE) OR (INE) OR (TE) OR (NOT(nPOR)) OR (ST) OR (SPIE)$.

Table 15 Failure reported in the global status byte and global error flag

Type of error	Failure reported in the global status byte	Global error flag
VDS monitoring error	DSOV = 1	1
Supply error	SUPE = 1	1
Input error	INE = 1	1
Temperature error	TE = 1	1
Power-on-reset	NPOR = 0	1
Stop mode	ST = 1	1
SPI protocol error	SPIE = 1	1

(table continues...)

Table 15 (continued) Failure reported in the global status byte and global error flag

Type of error	Failure reported in the global status byte	Global error flag
No error and no power-on-reset	DSOV = 0 SUPE = 0 INE = 0 TE = 0 NPOR = 1 ST = 0 SPIE = 0	0

8.4 SPI error detection

The SPI incorporates an error flag SPIE in [STAT](#) and [Global status byte](#) to supervise and preserve the data integrity. The SPIE bit is set in the next SPI communication if following SPI errors are detected during a given frame:

- The number of SCLK clock pulses received for the duration CSN = 0 is (protocol error):
 - Not zero
 - Or less than 16
 - Or more than 16
- A watchdog trigger with an incorrect checksum bit is sent
- The microcontroller sends an SPI command to an unused address (protocol error)
- A clock polarity error is detected, see the [Figure 22](#) below: the incoming clock signal was high during CSN rising or falling edges (protocol error)
- Any command to clear status registers in stop mode and not belonging to the exit sequence
- Any command to write control registers in stop mode and not belonging to the exit sequence

To ensure a correct SPI communication, the following conditions have to be fulfilled:

- SCLK must be low for a minimum t_{BEF} before CSN falling edge and t_{lead} after CSN falling edge
- SCLK must be low for a minimum t_{lag} before CSN rising edge and t_{BEH} after CSN rising edge

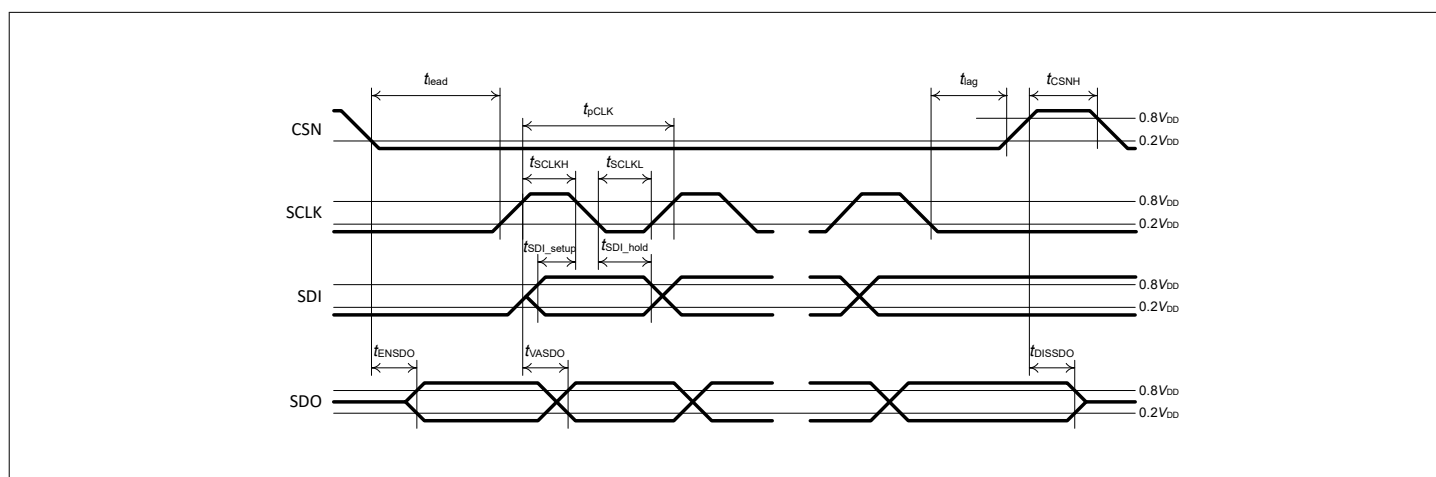

Figure 20 SPI timing parameters

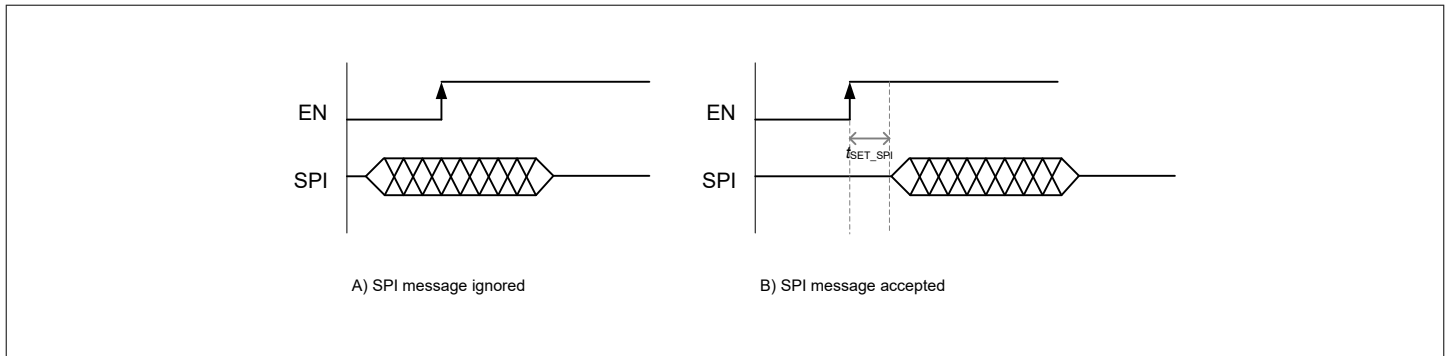

Figure 21 Setup time from EN rising edge to first SPI communication

The SPI error bit SPIE is reset under the following conditions:

- The SPI error bit SPIE can be reset only in normal mode when the microcontroller must clear the SPIE bit in [STAT](#)
- In stop mode the microcontroller must enter normal operation mode and clear the SPIE bit in [STAT](#)

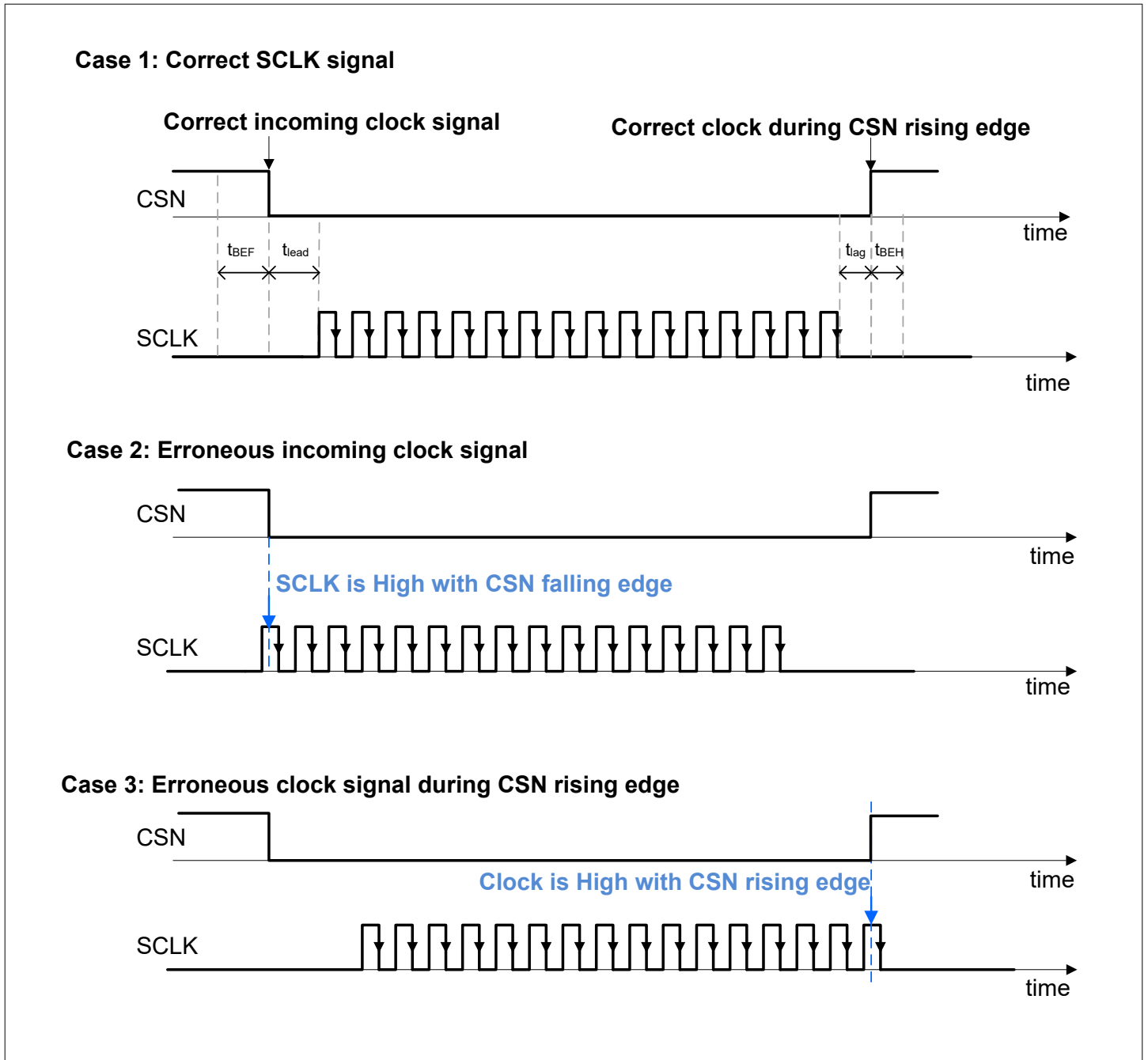

Figure 22 Polarity error

8.5 Electrical characteristics SPI

Table 16 SPI electrical characteristics

$V_{SM} = 8.0\text{ V}$ to 60 V , $V_{DD} = 3\text{ V}$ to 5.5 V , $T_j = -40^\circ\text{C}$ to $+175^\circ\text{C}$, all voltages with respect to ground, positive current flowing into pin (unless otherwise specified)

Parameter	Symbol	Values			Unit	Note or condition	P-Number
		Min.	Typ.	Max.			
SPI frequency							
Maximum SPI frequency	$f_{SPI,max}$	–	–	4	MHz	–	P_SPI_01_01
Delay from EN rising edge to first SPI frame							
SPI interface setup time	t_{SET_SPI}	–	–	500	μs	–	P_SPI_01_02
SPI interface (SDI, SCLK, CSN)							
High input voltage threshold (VDD = 5 V)	V_{IH1}	2.5	–	–	V	$V_{DD} = 5\text{ V}$	P_SPI_01_03
High input voltage threshold (VDD = 3.3 V)	V_{IH2}	1.5	–	–	V	$V_{DD} = 3.3\text{ V}$	P_SPI_01_04
Low input voltage threshold (VDD = 5 V)	V_{IL1}	–	–	0.8	V	$V_{DD} = 5\text{ V}$	P_SPI_01_05
Low input voltage threshold (VDD = 3.3 V)	V_{IL2}	–	–	0.6	V	$V_{DD} = 3.3\text{ V}$	P_SPI_01_06
Hysteresis of input voltage (VDD = 5 V)	V_{IHY1}	100	–	–	mV	$V_{DD} = 5\text{ V}$	P_SPI_01_07
Hysteresis of input voltage (VDD = 3.3 V)	V_{IHY2}	100	–	–	mV	$V_{DD} = 3.3\text{ V}$	P_SPI_01_08
Pull down resistor at input pin ILx, IHx	R_{pd}	25	40	60	$\text{k}\Omega$	–	P_SPI_01_09
Pull up resistor at pin CSN	R_{PU_CSN}	25	40	60	$\text{k}\Omega$	–	P_SPI_01_10
Pull down resistor at pin SDI, SCLK	R_{PD_SDI} , R_{PD_SCLK}	25	40	60	$\text{k}\Omega$	–	P_SPI_01_11
Input capacitance at pin CSN, SDI and SCLK	C_I	–	–	10	pF	$0\text{ V} < V_{DD} < 5.5\text{ V}$	P_SPI_01_12

Input interface, logic outputs SDO

High output voltage level	V_{SDOH}	$V_{DD} - 0.4$	–	–	V	$ I_{SDOH} = 1.6\text{ mA}$	P_SPI_01_13
---------------------------	------------	----------------	---	---	---	------------------------------	-------------

(table continues...)

Table 16 (continued) SPI electrical characteristics

$V_{SM} = 8.0\text{ V to }60\text{ V}$, $V_{DD} = 3\text{ V to }5.5\text{ V}$, $T_j = -40^\circ\text{C to }+175^\circ\text{C}$, all voltages with respect to ground, positive current flowing into pin (unless otherwise specified)

Parameter	Symbol	Values			Unit	Note or condition	P-Number
		Min.	Typ.	Max.			
Low output voltage level	V_{SDOL}	–	–	0.4	V	$ I_{SDOL} = 1.6\text{ mA}$	P_SPI_01_14
Tri-state leakage current	I_{SDOLK}	-10	–	10	μA	$V_{CSN} = V_{DD}$; $0\text{ V} < V_{SDO} < V_{DD}$	P_SPI_01_15
Tri-state input capacitance	C_{SDO}	–	–	15	pF	–	P_SPI_01_16

Data input timing

SCLK period	t_{pCLK}	250	–	–	ns	–	P_SPI_01_17
SCLK high time	t_{SCLKH}	0.45 * t_{pCLK}	–	0.55 * t_{pCLK}	ns	–	P_SPI_01_18
SCLK low time	t_{SCLKL}	0.45 * t_{pCLK}	–	0.55 * t_{pCLK}	ns	–	P_SPI_01_19
CSN setup time	t_{lead}	250	–	–	ns	–	P_SPI_01_21
SCLK setup time	t_{lag}	250	–	–	ns	–	P_SPI_01_22
SCLK low after CSN high	t_{BEH}	125	–	–	ns	–	P_SPI_01_23
SDI setup time	t_{SDI_setup}	100	–	–	ns	–	P_SPI_01_24
SDI hold time	t_{SDI_hold}	50	–	–	ns	–	P_SPI_01_25
Input signal rise time at pin SDI, SCLK, CSN	t_{rIN}	–	–	50	ns	–	P_SPI_01_26
Input signal fall time at pin SDI, SCLK, CSN	t_{fIN}	–	–	50	ns	–	P_SPI_01_27
Minimum CSN high time	t_{CSNH}	3	–	–	μs	–	P_SPI_01_28

Data output timing

SDO rise time	t_{rSDO}	–	30	80	ns	$C_{Load} = 100\text{ pF}$	P_SPI_01_29
SDO fall time	t_{fSDO}	–	30	80	ns	$C_{Load} = 100\text{ pF}$	P_SPI_01_30
SDO enable time after CSN falling edge	t_{ENSDO}	–	–	80	ns	–	P_SPI_01_31
SDO disable time after CSN	t_{DISSDO}	–	–	50	ns	–	P_SPI_01_32

(table continues...)

Table 16 (continued) SPI electrical characteristics

$V_{SM} = 8.0\text{ V to }60\text{ V}$, $V_{DD} = 3\text{ V to }5.5\text{ V}$, $T_j = -40^\circ\text{C to }+175^\circ\text{C}$, all voltages with respect to ground, positive current flowing into pin (unless otherwise specified)

Parameter	Symbol	Values			Unit	Note or condition	P-Number
		Min.	Typ.	Max.			
SDO valid time for VDD = 5 V	t_{VASDO}	–	–	80	ns	$V_{SDO} < 0.2 * V_{DD}$, $V_{SDO} > 0.8 * V_{DD}$ $C_{load} = 100\text{ pF}$	P_SPI_01_33

9 Register specification

9.1 Register overview

Table 17 Register overview

Register short name	Register long name
GENCTRL1	General control register 1
GENCTRL2	General control register 2
GENCTRL3	General control register 3
GENCTRL4	General control register 4
GENCTRL5	General control register 5
GENCTRL6	General control register 6
GENCTRL7	General control register 7
GENCTRL8	General control register 8
GENCTRL9	General control register 9
GENCTRL10	General control register 10
GENCTRL11	General control register 11
GENCTRL12	General control register 12
GENCTRL13	General control register 13
STAT	General status register
STAT1	Global status register 1
STAT2	Global status register 2
STAT3	Global status register 3
STAT4	Global status register 4
STAT5	Effective high-side MOSFET turn-on delay PWM1
STAT6	Effective high-side MOSFET turn-off delay PWM1
STAT7	Effective low-side MOSFET turn-on delay PWM1
STAT8	Effective low-side MOSFET turn-off delay PWM1
STAT9	Effective high-side MOSFET turn-on delay PWM2
STAT10	Effective high-side MOSFET turn-off delay PWM2
STAT11	Effective low-side MOSFET turn-on delay PWM2
STAT12	Effective low-side MOSFET turn-off delay PWM2
STAT13	Effective high-side MOSFET turn-on delay PWM3
STAT14	Effective high-side MOSFET turn-off delay PWM3
STAT15	Effective low-side MOSFET turn-on delay PWM3
STAT16	Effective low-side MOSFET turn-off delay PWM3
STAT17	Effective high-side MOSFET rise time PWM1

(table continues...)

Table 17 (continued) Register overview

Register short name	Register long name
STAT18	Effective high-side MOSFET fall time PWM1
STAT19	Effective low-side MOSFET rise time PWM1
STAT20	Effective low-side MOSFET fall time PWM1
STAT21	Effective high-side MOSFET rise time PWM2
STAT22	Effective high-side MOSFET fall time PWM2
STAT23	Effective low-side MOSFET rise time PWM2
STAT24	Effective low-side MOSFET fall time PWM2
STAT25	Effective high-side MOSFET rise time PWM3
STAT26	Effective high-side MOSFET fall time PWM3
STAT27	Effective low-side MOSFET rise time PWM3
STAT28	Effective low-side MOSFET fall time PWM3

9.2 Control Registers

- The control registers will be reset to default values after power up or reset
- There are different bit types:
 - 'r' = READ: read only bits (or reserved bits)
 - 'rw' = READ/WRITE: readable and writable bits
- Reserved bits are marked as "Reserved" and always read as 0. The respective bits shall also be programmed as 0
- Reading a register is done word wise by setting the SPI bit OP to 0 (= read only)
- The SPI control registers are not cleared or changed automatically. It must be done by the microcontroller via SPI programming

9.2.1 General control register 1

Table 18 General control register 1 (000 0001B) Reset value: 0010 0001B

7	6	5	4	3	2	1	0
HBFREQ	BD_EN	HLSOV_DIS	DG	IGx_SEL	UNLOCK	FMODE_1	FMODE_0
rw	rw	rw	rw	rw	rw	rw	rw

Field	Bits	Type	Description
HBFREQ	7	rw	HB frequency 0 _B 37.5 MHz (default) 1 _B 18.75 MHz
BD_EN	6	rw	Bridge driver enable 0 _B the bridge driver is disabled 1 _B the bridge driver in enabled

(table continues...)

Table 18 (continued) General control register 1 (000 0001B) Reset value: 0010 0001B

HLSOV_DIS	5	rw	Over-current protection 0 _B when VDS_HSx or VDS_LSx ≥ VDSTH, all gate drivers will be switched off 1 _B when VDS_HSx or VDS_LSx ≥ VDSTH, the gate drivers of the same half - bridge will be switch off (default)
DG	4	rw	Deglitch for high speed comparator 0 _B the deglitch feature is disabled (default) 1 _B the deglitch feature is enabled Note: Enable deglitch feature can ignore small glitches at the comparator input.
IGx_SEL	3	rw	Charge/discharge current extension bit: 0 _B keep the current set by corresponding bits (default) 1 _B enlarge all currents to max. 480 mA Note: I represents the IPRECHG, ICHG, ICHGM, IHOLD, IPREDISCHG, IDISCHG, IDISCHGM, IPOSTCHG and IDISCHG_ST.
UNLOCK	2	rw	Unlock bit to disable the watchdog 0 _B WDDIS cannot be reset (default) 1 _B WDDIS can be reset in following SPI frame
FMODE	[1:0]	rw	Frequency modulation 00 _B no modulation 01 _B modulation frequency 15.6 kHz (default) 10 _B modulation frequency 31.2 kHz 11 _B modulation frequency 62.5 kHz

9.2.2 General control register 2

Table 19 General control register 2 (000 0010_B) Reset value: x000 0100_B

7	6	5	4	3	2	1	0
CHECKSUM	RES	RES	RES	RES	WDPER		
rw	r	r	r	r	rw		

Field	Bits	Type	Description
CHECKSUM	7	rw	Watchdog Setting Check Sum Bit The sum of bits 6:0 needs to have even parity 0 _B counts as 0 for checksum calculation 1 _B counts as 1 for checksum calculation
RES	6	r	Reserved. Always read as 0
RES	5	r	Reserved. Always read as 0
RES	4	r	Reserved. Always read as 0

(table continues...)

Table 19 (continued) **General control register 2 (000 0010_B)** Reset value: x000 0100_B

RES	3	r	Reserved. Always read as 0
WDPER	[2:0]	rw	Watchdog period 000 _B 2 ms 001 _B 4 ms 010 _B 8 ms 011 _B 16 ms 100 _B 64 ms (default) 101 _B 128 ms 110 _B 256 ms 111 _B 512 ms

9.2.3 General control register 3

Table 20 **General control register 3 (000 0011_B)** Reset value: 0000 0001_B

7	6	5	4	3	2	1	0
WDDIS	TWDIS	HB3DIAG	HB2DIAG	HB1DIAG	VDSTH		
rw	rw	rw	rw	rw	rw		

Field	Bits	Type	Description
WDDIS	7	rw	Watchdog disable bit 0 _B the watchdog is enabled (default) 1 _B the watchdog is disabled if the previous SPI frame has set UNLOCK bit (GENCTRL1) Once the watchdog is disabled, it is directly re-enabled by resetting WDDIS.
TWDIS	6	rw	Thermal warning disable 0 _B TW is reported in GEF and set in global status register (default) 1 _B TW is not reported in GEF, but it is set in global status register
HB3DIAG	5	rw	Control of HB3 off-state current source and current sink 0 _B pull-down deactivated (default) 1 _B pull-down activated
HB2DIAG	4	rw	Control of HB2 off-state current source and current sink 0 _B pull-down deactivated (default) 1 _B pull-down activated
HB1DIAG	3	rw	Control of HB1 off-state current source and current sink 0 _B pull-down deactivated (default) 1 _B pull-down activated

(table continues...)

Table 20 (continued) **General control register 3 (000 0011_B)** Reset value: 0000 0001_B

VDSTH	[2:0]	rw	Drain - source overvoltage threshold 000 _B : 145 mV 001 _B : 195 mV(default) 010 _B : 245 mV 011 _B : 295 mV 100 _B : 390 mV 101 _B : 490 mV 110 _B : 590 mV 111 _B : 2 V
--------------	-------	----	---

9.2.4 General control register 4

Table 21 **General control register 4 (000 0100_B)** Reset value: 0000 1111_B

7	6	5	4	3	2	1	0
IPRECHG_T		IPRECHG					
rw		rw					

Field	Bits	Type	Description		
IPRECHG_T	[7:6]	rw	Pre - charge time of HB1 - HB3 00 _B 100 ns (default) 01 _B 150 ns 10 _B 200 ns 11 _B 250 ns		
IPRECHG	[5:0]	rw	Pre - charge current of HB1 - HB3		
				IGx_SEL = 0 _B	IGx_SEL = 1 _B
			00 0000 _B	11.6 mA	11.6 mA
			00 0001 _B	14.8 mA	15.8 mA
			00 0010 _B	18.1 mA	20.1 mA
			00 0011 _B	21.3 mA	24.3 mA
			00 0100 _B	24.5 mA	28.5 mA
			00 0101 _B	27.7 mA	32.7 mA
			00 0110 _B	31.0 mA	37.0 mA
			00 0111 _B	34.2 mA	41.2 mA
			00 1000 _B	37.4 mA	45.4 mA
			00 1001 _B	40.6 mA	49.7 mA
			00 1010 _B	43.9 mA	53.9 mA
			00 1011 _B	47.1 mA	58.1 mA

(table continues...)

Table 21 (continued) **General control register 4 (000 0100_B) Reset value: 0000 1111_B**

		00 1100 _B	50.3 mA	62.4 mA
		00 1101 _B	53.6 mA	66.6 mA
		00 1110 _B	56.8 mA	70.8 mA
		00 1111 _B (def.)	60.0 mA	75.0 mA
		01 0000 _B	65.4 mA	82.1 mA
		01 0001 _B	70.8 mA	89.3 mA
		01 0010 _B	76.1 mA	96.4 mA
		01 0011 _B	81.5 mA	103.5 mA
		01 0100 _B	86.9 mA	111.6 mA
		01 0101 _B	92.3 mA	117.8 mA
		01 0110 _B	97.6 mA	124.9 mA
		01 0111 _B	103.0 mA	132.0 mA
		01 1000 _B	108.4 mA	139.1 mA
		01 1001 _B	113.8 mA	146.3 mA
		01 1010 _B	119.1 mA	153.4 mA
		01 1011 _B	124.5 mA	160.5 mA
		01 1100 _B	129.9 mA	167.6 mA
		01 1101 _B	135.3 mA	174.8 mA
		01 1110 _B	140.6 mA	181.9 mA
		01 1111 _B	146.0 mA	189.0 mA
		10 0000 _B	152.9 mA	197.8 mA
		10 0001 _B	159.8 mA	206.6 mA
		10 0010 _B	166.6 mA	215.4 mA
		10 0011 _B	173.5 mA	224.2 mA
		10 0100 _B	180.4 mA	233.1 mA
		10 0101 _B	187.2 mA	241.9 mA
		10 0110 _B	194.1 mA	250.7 mA
		10 0111 _B	201.0 mA	259.5 mA
		10 1000 _B	207.9 mA	268.3 mA
		10 1001 _B	214.8 mA	277.1 mA
		10 1010 _B	221.6 mA	285.9 mA
		10 1011 _B	228.5 mA	294.7 mA
		10 1100 _B	235.4 mA	303.5 mA
		10 1101 _B	242.3 mA	312.3 mA
		10 1110 _B	249.1 mA	321.2 mA

(table continues...)

Table 21 (continued) **General control register 4 (000 0100_B) Reset value: 0000 1111_B**

			10 1111 _B	256.0 mA	330.0 mA
			11 0000 _B	263.4 mA	339.4 mA
			11 0001 _B	270.9 mA	348.8 mA
			11 0010 _B	278.3 mA	358.1 mA
			11 0011 _B	285.8 mA	367.5 mA
			11 0100 _B	293.2 mA	376.8 mA
			11 0101 _B	300.6 mA	386.2 mA
			11 0110 _B	308.1 mA	395.6 mA
			11 0111 _B	315.5 mA	405.0 mA
			11 1000 _B	323.0 mA	414.4 mA
			11 1001 _B	330.4 mA	423.8 mA
			11 1010 _B	337.8 mA	433.1 mA
			11 1011 _B	345.3 mA	442.5 mA
			11 1100 _B	352.7 mA	451.9 mA
			11 1101 _B	360.2 mA	461.3 mA
			11 1110 _B	367.6 mA	470.6 mA
			11 1111 _B	375.0 mA	480.0 mA

9.2.5 General control register 5

Table 22 **General control register 5 (000 0101_B) Reset value: 0000 1111_B**

7	6	5	4	3	2	1	0
ICHG_T		ICHG					
rw		rw					

Field	Bits	Type	Description		
ICHG_T	[7:6]	rw	Charge time of HB1 - HB3		
			00 _B 200 ns (default)		
			01 _B 400 ns		
			10 _B 600 ns		
			11 _B 800 ns		
ICHG	[5:0]	rw	Charge current of HB1 - HB3		
				IG _X _SEL = 0 _B	IG _X _SEL = 1 _B
			00 0000 _B	11.6 mA	11.6 mA
			00 0001 _B	14.8 mA	15.8 mA
			00 0010 _B	18.1 mA	20.1 mA

(table continues...)

Table 22 (continued) General control register 5 (000 0101_B) Reset value: 0000 1111_B

		00 0011 _B	21.3 mA	24.3 mA
		00 0100 _B	24.5 mA	28.5 mA
		00 0101 _B	27.7 mA	32.7 mA
		00 0110 _B	31.0 mA	37.0 mA
		00 0111 _B	34.2 mA	41.2 mA
		00 1000 _B	37.4 mA	45.4 mA
		00 1001 _B	40.6 mA	49.7 mA
		00 1010 _B	43.9 mA	53.9 mA
		00 1011 _B	47.1 mA	58.1 mA
		00 1100 _B	50.3 mA	62.4 mA
		00 1101 _B	53.6 mA	66.6 mA
		00 1110 _B	56.8 mA	70.8 mA
		00 1111 _B (def.)	60.0 mA	75.0 mA
		01 0000 _B	65.4 mA	82.1 mA
		01 0001 _B	70.8 mA	89.3 mA
		01 0010 _B	76.1 mA	96.4 mA
		01 0011 _B	81.5 mA	103.5 mA
		01 0100 _B	86.9 mA	111.6 mA
		01 0101 _B	92.3 mA	117.8 mA
		01 0110 _B	97.6 mA	124.9 mA
		01 0111 _B	103.0 mA	132.0 mA
		01 1000 _B	108.4 mA	139.1 mA
		01 1001 _B	113.8 mA	146.3 mA
		01 1010 _B	119.1 mA	153.4 mA
		01 1011 _B	124.5 mA	160.5 mA
		01 1100 _B	129.9 mA	167.6 mA
		01 1101 _B	135.3 mA	174.8 mA
		01 1110 _B	140.6 mA	181.9 mA
		01 1111 _B	146.0 mA	189.0 mA
		10 0000 _B	152.9 mA	197.8 mA
		10 0001 _B	159.8 mA	206.6 mA
		10 0010 _B	166.6 mA	215.4 mA
		10 0011 _B	173.5 mA	224.2 mA
		10 0100 _B	180.4 mA	233.1 mA
		10 0101 _B	187.2 mA	241.9 mA

(table continues...)

Table 22 (continued) General control register 5 (000 0101_B) Reset value: 0000 1111_B

		10 0110 _B	194.1 mA	250.7 mA
		10 0111 _B	201.0 mA	259.5 mA
		10 1000 _B	207.9 mA	268.3 mA
		10 1001 _B	214.8 mA	277.1 mA
		10 1010 _B	221.6 mA	285.9 mA
		10 1011 _B	228.5 mA	294.7 mA
		10 1100 _B	235.4 mA	303.5 mA
		10 1101 _B	242.3 mA	312.3 mA
		10 1110 _B	249.1 mA	321.2 mA
		10 1111 _B	256.0 mA	330.0 mA
		11 0000 _B	263.4 mA	339.4 mA
		11 0001 _B	270.9 mA	348.8 mA
		11 0010 _B	278.3 mA	358.1 mA
		11 0011 _B	285.8 mA	367.5 mA
		11 0100 _B	293.2 mA	376.8 mA
		11 0101 _B	300.6 mA	386.2 mA
		11 0110 _B	308.1 mA	395.6 mA
		11 0111 _B	315.5 mA	405.0 mA
		11 1000 _B	323.0 mA	414.4 mA
		11 1001 _B	330.4 mA	423.8 mA
		11 1010 _B	337.8 mA	433.1 mA
		11 1011 _B	345.3 mA	442.5 mA
		11 1100 _B	352.7 mA	451.9 mA
		11 1101 _B	360.2 mA	461.3 mA
		11 1110 _B	367.6 mA	470.6 mA
		11 1111 _B	375.0 mA	480.0 mA

9.2.6 General control register 6

Table 23 General control register 6 (000 0110_B) Reset value: 0000 1111_B

7	6	5	4	3	2	1	0
GEF_CONFIG			IPOSTCHG				
rw			rw				

Field	Bits	Type	Description
-------	------	------	-------------

(table continues...)

Table 23 (continued) General control register 6 (000 0110_B) Reset value: 0000 1111_B

GEF_CONFIG	[7:6]	rw	Global Error Flag 00 _B GEF (default state) 01 _B BEMF1 10 _B BEMF2 11 _B BEMF3		
IPOSTCHG	[5:0]	rw	Post - charge current of HB1 - HB3		
				IG _X _SEL = 0 _B	IG _X _SEL = 1 _B
			00 0000 _B	11.6 mA	11.6 mA
			00 0001 _B	14.8 mA	15.8 mA
			00 0010 _B	18.1 mA	20.1 mA
			00 0011 _B	21.3 mA	24.3 mA
			00 0100 _B	24.5 mA	28.5 mA
			00 0101 _B	27.7 mA	32.7 mA
			00 0110 _B	31.0 mA	37.0 mA
			00 0111 _B	34.2 mA	41.2 mA
			00 1000 _B	37.4 mA	45.4 mA
			00 1001 _B	40.6 mA	49.7 mA
			00 1010 _B	43.9 mA	53.9 mA
			00 1011 _B	47.1 mA	58.1 mA
			00 1100 _B	50.3 mA	62.4 mA
			00 1101 _B	53.6 mA	66.6 mA
			00 1110 _B	56.8 mA	70.8 mA
			00 1111 _B (def.)	60.0 mA	75.0 mA
			01 0000 _B	65.4 mA	82.1 mA
			01 0001 _B	70.8 mA	89.3 mA
			01 0010 _B	76.1 mA	96.4 mA
			01 0011 _B	81.5 mA	103.5 mA
			01 0100 _B	86.9 mA	111.6 mA
			01 0101 _B	92.3 mA	117.8 mA
			01 0110 _B	97.6 mA	124.9 mA
			01 0111 _B	103.0 mA	132.0 mA
			01 1000 _B	108.4 mA	139.1 mA
01 1001 _B	113.8 mA	146.3 mA			
01 1010 _B	119.1 mA	153.4 mA			
01 1011 _B	124.5 mA	160.5 mA			

(table continues...)

Table 23 (continued) General control register 6 (000 0110_B) Reset value: 0000 1111_B

		01 1100 _B	129.9 mA	167.6 mA
		01 1101 _B	135.3 mA	174.8 mA
		01 1110 _B	140.6 mA	181.9 mA
		01 1111 _B	146.0 mA	189.0 mA
		10 0000 _B	152.9 mA	197.8 mA
		10 0001 _B	159.8 mA	206.6 mA
		10 0010 _B	166.6 mA	215.4 mA
		10 0011 _B	173.5 mA	224.2 mA
		10 0100 _B	180.4 mA	233.1 mA
		10 0101 _B	187.2 mA	241.9 mA
		10 0110 _B	194.1 mA	250.7 mA
		10 0111 _B	201.0 mA	259.5 mA
		10 1000 _B	207.9 mA	268.3 mA
		10 1001 _B	214.8 mA	277.1 mA
		10 1010 _B	221.6 mA	285.9 mA
		10 1011 _B	228.5 mA	294.7 mA
		10 1100 _B	235.4 mA	303.5 mA
		10 1101 _B	242.3 mA	312.3 mA
		10 1110 _B	249.1 mA	321.2 mA
		10 1111 _B	256.0 mA	330.0 mA
		11 0000 _B	263.4 mA	339.4 mA
		11 0001 _B	270.9 mA	348.8 mA
		11 0010 _B	278.3 mA	358.1 mA
		11 0011 _B	285.8 mA	367.5 mA
		11 0100 _B	293.2 mA	376.8 mA
		11 0101 _B	300.6 mA	386.2 mA
		11 0110 _B	308.1 mA	395.6 mA
		11 0111 _B	315.5 mA	405.0 mA
		11 1000 _B	323.0 mA	414.4 mA
		11 1001 _B	330.4 mA	423.8 mA
		11 1010 _B	337.8 mA	433.1 mA
		11 1011 _B	345.3 mA	442.5 mA
		11 1100 _B	352.7 mA	451.9 mA
		11 1101 _B	360.2 mA	461.3 mA
		11 1110 _B	367.6 mA	470.6 mA

(table continues...)

Table 23 (continued) General control register 6 (000 0110_B) Reset value: 0000 1111_B

			11 1111 _B	375.0 mA	480.0 mA
--	--	--	----------------------	----------	----------

9.2.7 General control register 7

Table 24 General control register 7 (000 0111_B) Reset value: 0000 1111_B

7	6	5	4	3	2	1	0
IPREDISCHG_T		IPREDISCHG					
rw		rw					

Field	Bits	Type	Description		
IPREDISCHG_T	[7:6]	rw	Pre - discharge time of HB1 - HB3 00 _B 100 ns (default) 01 _B 150 ns 10 _B 200 ns 11 _B 250 ns		
			Pre - discharge current of HB1 - HB3		
IPREDISCHG	[5:0]	rw			
				IGx_SEL = 0 _B	IGx_SEL = 1 _B
			00 0000 _B	11.6 mA	11.6 mA
			00 0001 _B	14.8 mA	15.8 mA
			00 0010 _B	18.1 mA	20.1 mA
			00 0011 _B	21.3 mA	24.3 mA
			00 0100 _B	24.5 mA	28.5 mA
			00 0101 _B	27.7 mA	32.7 mA
			00 0110 _B	31.0 mA	37.0 mA
			00 0111 _B	34.2 mA	41.2 mA
			00 1000 _B	37.4 mA	45.4 mA
			00 1001 _B	40.6 mA	49.7 mA
			00 1010 _B	43.9 mA	53.9 mA
			00 1011 _B	47.1 mA	58.1 mA
			00 1100 _B	50.3 mA	62.4 mA
			00 1101 _B	53.6 mA	66.6 mA
			00 1110 _B	56.8 mA	70.8 mA
			00 1111 _B (def.)	60.0 mA	75.0 mA
01 0000 _B	65.4 mA	82.1 mA			
01 0001 _B	70.8 mA	89.3 mA			
01 0010 _B	76.1 mA	96.4 mA			

(table continues...)

Table 24 (continued) General control register 7 (000 0111_B) Reset value: 0000 1111_B

		01 0011 _B	81.5 mA	103.5 mA
		01 0100 _B	86.9 mA	111.6 mA
		01 0101 _B	92.3 mA	117.8 mA
		01 0110 _B	97.6 mA	124.9 mA
		01 0111 _B	103.0 mA	132.0 mA
		01 1000 _B	108.4 mA	139.1 mA
		01 1001 _B	113.8 mA	146.3 mA
		01 1010 _B	119.1 mA	153.4 mA
		01 1011 _B	124.5 mA	160.5 mA
		01 1100 _B	129.9 mA	167.6 mA
		01 1101 _B	135.3 mA	174.8 mA
		01 1110 _B	140.6 mA	181.9 mA
		01 1111 _B	146.0 mA	189.0 mA
		10 0000 _B	152.9 mA	197.8 mA
		10 0001 _B	159.8 mA	206.6 mA
		10 0010 _B	166.6 mA	215.4 mA
		10 0011 _B	173.5 mA	224.2 mA
		10 0100 _B	180.4 mA	233.1 mA
		10 0101 _B	187.2 mA	241.9 mA
		10 0110 _B	194.1 mA	250.7 mA
		10 0111 _B	201.0 mA	259.5 mA
		10 1000 _B	207.9 mA	268.3 mA
		10 1001 _B	214.8 mA	277.1 mA
		10 1010 _B	221.6 mA	285.9 mA
		10 1011 _B	228.5 mA	294.7 mA
		10 1100 _B	235.4 mA	303.5 mA
		10 1101 _B	242.3 mA	312.3 mA
		10 1110 _B	249.1 mA	321.2 mA
		10 1111 _B	256.0 mA	330.0 mA
		11 0000 _B	263.4 mA	339.4 mA
		11 0001 _B	270.9 mA	348.8 mA
		11 0010 _B	278.3 mA	358.1 mA
		11 0011 _B	285.8 mA	367.5 mA
		11 0100 _B	293.2 mA	376.8 mA
		11 0101 _B	300.6 mA	386.2 mA

(table continues...)

Table 24 (continued) **General control register 7 (000 0111_B) Reset value: 0000 1111_B**

			11 0110 _B	308.1 mA	395.6 mA
			11 0111 _B	315.5 mA	405.0 mA
			11 1000 _B	323.0 mA	414.4 mA
			11 1001 _B	330.4 mA	423.8 mA
			11 1010 _B	337.8 mA	433.1 mA
			11 1011 _B	345.3 mA	442.5 mA
			11 1100 _B	352.7 mA	451.9 mA
			11 1101 _B	360.2 mA	461.3 mA
			11 1110 _B	367.6 mA	470.6 mA
			11 1111 _B	375.0 mA	480.0 mA

9.2.8 General control register 8

Table 25 **General control register 8 (000 1000_B) Reset value: 0000 1111_B**

7	6	5	4	3	2	1	0
IHOLD		IDISCHG					
rw		rw					

Field	Bits	Type	Description		
IHOLD	[7:6]	rw	Gate driver hold current IHOLD		
				IGx_SEL = 0 _B	IGx_SEL = 1 _B
			00 _B (def.)	11.6 mA	11.6 mA
			01 _B	27.7 mA	32.7 mA
			10 _B	40.6 mA	49.7 mA
IDISCHG	[5:0]	rw	Discharge current of HB1 - HB3		
				IGx_SEL = 0 _B	IGx_SEL = 1 _B
			00 0000 _B	11.6 mA	11.6 mA
			00 0001 _B	14.8 mA	15.8 mA
			00 0010 _B	18.1 mA	20.1 mA
			00 0011 _B	21.3 mA	24.3 mA
			00 0100 _B	24.5 mA	28.5 mA
			00 0101 _B	27.7 mA	32.7 mA
			00 0110 _B	31.0 mA	37.0 mA
			00 0111 _B	34.2 mA	41.2 mA
			00 1000 _B	37.4 mA	45.4 mA

(table continues...)

Table 25 (continued) General control register 8 (000 1000_B) Reset value: 0000 1111_B

		00 1001 _B	40.6 mA	49.7 mA
		00 1010 _B	43.9 mA	53.9 mA
		00 1011 _B	47.1 mA	58.1 mA
		00 1100 _B	50.3 mA	62.4 mA
		00 1101 _B	53.6 mA	66.6 mA
		00 1110 _B	56.8 mA	70.8 mA
		00 1111 _B (def.)	60.0 mA	75.0 mA
		01 0000 _B	65.4 mA	82.1 mA
		01 0001 _B	70.8 mA	89.3 mA
		01 0010 _B	76.1 mA	96.4 mA
		01 0011 _B	81.5 mA	103.5 mA
		01 0100 _B	86.9 mA	111.6 mA
		01 0101 _B	92.3 mA	117.8 mA
		01 0110 _B	97.6 mA	124.9 mA
		01 0111 _B	103.0 mA	132.0 mA
		01 1000 _B	108.4 mA	139.1 mA
		01 1001 _B	113.8 mA	146.3 mA
		01 1010 _B	119.1 mA	153.4 mA
		01 1011 _B	124.5 mA	160.5 mA
		01 1100 _B	129.9 mA	167.6 mA
		01 1101 _B	135.3 mA	174.8 mA
		01 1110 _B	140.6 mA	181.9 mA
		01 1111 _B	146.0 mA	189.0 mA
		10 0000 _B	152.9 mA	197.8 mA
		10 0001 _B	159.8 mA	206.6 mA
		10 0010 _B	166.6 mA	215.4 mA
		10 0011 _B	173.5 mA	224.2 mA
		10 0100 _B	180.4 mA	233.1 mA
		10 0101 _B	187.2 mA	241.9 mA
		10 0110 _B	194.1 mA	250.7 mA
		10 0111 _B	201.0 mA	259.5 mA
		10 1000 _B	207.9 mA	268.3 mA
		10 1001 _B	214.8 mA	277.1 mA
		10 1010 _B	221.6 mA	285.9 mA
		10 1011 _B	228.5 mA	294.7 mA

(table continues...)

Table 25 (continued) General control register 8 (000 1000_B) Reset value: 0000 1111_B

			10 1100 _B	235.4 mA	303.5 mA
			10 1101 _B	242.3 mA	312.3 mA
			10 1110 _B	249.1 mA	321.2 mA
			10 1111 _B	256.0 mA	330.0 mA
			11 0000 _B	263.4 mA	339.4 mA
			11 0001 _B	270.9 mA	348.8 mA
			11 0010 _B	278.3 mA	358.1 mA
			11 0011 _B	285.8 mA	367.5 mA
			11 0100 _B	293.2 mA	376.8 mA
			11 0101 _B	300.6 mA	386.2 mA
			11 0110 _B	308.1 mA	395.6 mA
			11 0111 _B	315.5 mA	405.0 mA
			11 1000 _B	323.0 mA	414.4 mA
			11 1001 _B	330.4 mA	423.8 mA
			11 1010 _B	337.8 mA	433.1 mA
			11 1011 _B	345.3 mA	442.5 mA
			11 1100 _B	352.7 mA	451.9 mA
			11 1101 _B	360.2 mA	461.3 mA
			11 1110 _B	367.6 mA	470.6 mA
			11 1111 _B	375.0 mA	480.0 mA

9.2.9 General control register 9

Table 26 General control register 9 (000 1001_B) Reset value: 0000 1111_B

7	6	5	4	3	2	1	0
CPEN	CPREC	ICHGM					
rw	rw	rw					

Field	Bits	Type	Description
CPEN	7	rw	Charge pump enable 0 _B disable CP1 and CP2 modules (default) 1 _B enable CP1 and CP2 modules
CPREC	6	rw	Charge pump automatic recovery enable 0 _B disable the automatic recovery for CP1 and CP2 when VSM left OV/UV conditions (default) 1 _B enable the automatic recovery for CP1 and CP2 when VSM left OV/UV conditions

(table continues...)

Table 26 (continued) General control register 9 (000 1001_B) Reset value: 0000 1111_B

IC _{HGM}	[5:0]	rw	Middle charge current of HB1 - HB3		
				IG _{x_SEL} = 0 _B	IG _{x_SEL} = 1 _B
			00 0000 _B	11.6 mA	11.6 mA
00 0001 _B	14.8 mA	15.8 mA			
00 0010 _B	18.1 mA	20.1 mA			
00 0011 _B	21.3 mA	24.3 mA			
00 0100 _B	24.5 mA	28.5 mA			
00 0101 _B	27.7 mA	32.7 mA			
00 0110 _B	31.0 mA	37.0 mA			
00 0111 _B	34.2 mA	41.2 mA			
00 1000 _B	37.4 mA	45.4 mA			
00 1001 _B	40.6 mA	49.7 mA			
00 1010 _B	43.9 mA	53.9 mA			
00 1011 _B	47.1 mA	58.1 mA			
00 1100 _B	50.3 mA	62.4 mA			
00 1101 _B	53.6 mA	66.6 mA			
00 1110 _B	56.8 mA	70.8 mA			
00 1111 _B (def.)	60.0 mA	75.0 mA			
01 0000 _B	65.4 mA	82.1 mA			
01 0001 _B	70.8 mA	89.3 mA			
01 0010 _B	76.1 mA	96.4 mA			
01 0011 _B	81.5 mA	103.5 mA			
01 0100 _B	86.9 mA	111.6 mA			
01 0101 _B	92.3 mA	117.8 mA			
01 0110 _B	97.6 mA	124.9 mA			
01 0111 _B	103.0 mA	132.0 mA			
01 1000 _B	108.4 mA	139.1 mA			
01 1001 _B	113.8 mA	146.3 mA			
01 1010 _B	119.1 mA	153.4 mA			
01 1011 _B	124.5 mA	160.5 mA			
01 1100 _B	129.9 mA	167.6 mA			
01 1101 _B	135.3 mA	174.8 mA			
01 1110 _B	140.6 mA	181.9 mA			
01 1111 _B	146.0 mA	189.0 mA			
10 0000 _B	152.9 mA	197.8 mA			

(table continues...)

Table 26 (continued) General control register 9 (000 1001_B) Reset value: 0000 1111_B

			10 0001 _B	159.8 mA	206.6 mA
			10 0010 _B	166.6 mA	215.4 mA
			10 0011 _B	173.5 mA	224.2 mA
			10 0100 _B	180.4 mA	233.1 mA
			10 0101 _B	187.2 mA	241.9 mA
			10 0110 _B	194.1 mA	250.7 mA
			10 0111 _B	201.0 mA	259.5 mA
			10 1000 _B	207.9 mA	268.3 mA
			10 1001 _B	214.8 mA	277.1 mA
			10 1010 _B	221.6 mA	285.9 mA
			10 1011 _B	228.5 mA	294.7 mA
			10 1100 _B	235.4 mA	303.5 mA
			10 1101 _B	242.3 mA	312.3 mA
			10 1110 _B	249.1 mA	321.2 mA
			10 1111 _B	256.0 mA	330.0 mA
			11 0000 _B	263.4 mA	339.4 mA
			11 0001 _B	270.9 mA	348.8 mA
			11 0010 _B	278.3 mA	358.1 mA
			11 0011 _B	285.8 mA	367.5 mA
			11 0100 _B	293.2 mA	376.8 mA
			11 0101 _B	300.6 mA	386.2 mA
			11 0110 _B	308.1 mA	395.6 mA
			11 0111 _B	315.5 mA	405.0 mA
			11 1000 _B	323.0 mA	414.4 mA
			11 1001 _B	330.4 mA	423.8 mA
			11 1010 _B	337.8 mA	433.1 mA
			11 1011 _B	345.3 mA	442.5 mA
			11 1100 _B	352.7 mA	451.9 mA
			11 1101 _B	360.2 mA	461.3 mA
			11 1110 _B	367.6 mA	470.6 mA
			11 1111 _B	375.0 mA	480.0 mA

9.2.10 General control register 10

Table 27 General control register 10 (000 1010_B) Reset value: 0000 1111_B

7	6	5	4	3	2	1	0
---	---	---	---	---	---	---	---

(table continues...)

Table 27 (continued) General control register 10 (000 1010_B) Reset value: 0000 1111_B

TFBEMF	IDISCHGM
rw	rw

Field	Bits	Type	Description		
TFBEMF	[7:6]	rw	Back EMF filter time 00 _B 0.5 μs (def.) 01 _B 1 μs 10 _B 2 μs 11 _B 3 μs		
IDISCHGM	[5:0]	rw	Middle discharge current of HB1 - HB3		
				IGx_SEL = 0 _B	IGx_SEL = 1 _B
			00 0000 _B	11.6 mA	11.6 mA
			00 0001 _B	14.8 mA	15.8 mA
			00 0010 _B	18.1 mA	20.1 mA
			00 0011 _B	21.3 mA	24.3 mA
			00 0100 _B	24.5 mA	28.5 mA
			00 0101 _B	27.7 mA	32.7 mA
			00 0110 _B	31.0 mA	37.0 mA
			00 0111 _B	34.2 mA	41.2 mA
			00 1000 _B	37.4 mA	45.4 mA
			00 1001 _B	40.6 mA	49.7 mA
			00 1010 _B	43.9 mA	53.9 mA
			00 1011 _B	47.1 mA	58.1 mA
			00 1100 _B	50.3 mA	62.4 mA
			00 1101 _B	53.6 mA	66.6 mA
			00 1110 _B	56.8 mA	70.8 mA
			00 1111 _B (def.)	60.0 mA	75.0 mA
			01 0000 _B	65.4 mA	82.1 mA
			01 0001 _B	70.8 mA	89.3 mA
			01 0010 _B	76.1 mA	96.4 mA
			01 0011 _B	81.5 mA	103.5 mA
			01 0100 _B	86.9 mA	111.6 mA
01 0101 _B	92.3 mA	117.8 mA			
01 0110 _B	97.6 mA	124.9 mA			
01 0111 _B	103.0 mA	132.0 mA			

(table continues...)

Table 27 (continued) General control register 10 (000 1010_B) Reset value: 0000 1111_B

		01 1000 _B	108.4 mA	139.1 mA
		01 1001 _B	113.8 mA	146.3 mA
		01 1010 _B	119.1 mA	153.4 mA
		01 1011 _B	124.5 mA	160.5 mA
		01 1100 _B	129.9 mA	167.6 mA
		01 1101 _B	135.3 mA	174.8 mA
		01 1110 _B	140.6 mA	181.9 mA
		01 1111 _B	146.0 mA	189.0 mA
		10 0000 _B	152.9 mA	197.8 mA
		10 0001 _B	159.8 mA	206.6 mA
		10 0010 _B	166.6 mA	215.4 mA
		10 0011 _B	173.5 mA	224.2 mA
		10 0100 _B	180.4 mA	233.1 mA
		10 0101 _B	187.2 mA	241.9 mA
		10 0110 _B	194.1 mA	250.7 mA
		10 0111 _B	201.0 mA	259.5 mA
		10 1000 _B	207.9 mA	268.3 mA
		10 1001 _B	214.8 mA	277.1 mA
		10 1010 _B	221.6 mA	285.9 mA
		10 1011 _B	228.5 mA	294.7 mA
		10 1100 _B	235.4 mA	303.5 mA
		10 1101 _B	242.3 mA	312.3 mA
		10 1110 _B	249.1 mA	321.2 mA
		10 1111 _B	256.0 mA	330.0 mA
		11 0000 _B	263.4 mA	339.4 mA
		11 0001 _B	270.9 mA	348.8 mA
		11 0010 _B	278.3 mA	358.1 mA
		11 0011 _B	285.8 mA	367.5 mA
		11 0100 _B	293.2 mA	376.8 mA
		11 0101 _B	300.6 mA	386.2 mA
		11 0110 _B	308.1 mA	395.6 mA
		11 0111 _B	315.5 mA	405.0 mA
		11 1000 _B	323.0 mA	414.4 mA
		11 1001 _B	330.4 mA	423.8 mA
		11 1010 _B	337.8 mA	433.1 mA

(table continues...)

Table 27 (continued) General control register 10 (000 1010_B) Reset value: 0000 1111_B

			11 1011 _B	345.3 mA	442.5 mA
			11 1100 _B	352.7 mA	451.9 mA
			11 1101 _B	360.2 mA	461.3 mA
			11 1110 _B	367.6 mA	470.6 mA
			11 1111 _B	375.0 mA	480.0 mA

9.2.11 General control register 11

Table 28 General control register 11 (000 1011_B) Reset value: 0000 1111_B

7	6	5	4	3	2	1	0
TFVDS			IDISCHG_ST				
rw			rw				

Field	Bits	Type	Description		
TFVDS	[7:5]	rw	Drain - source overvoltage filter time of HB1 - HB3		
			000 _B 0.25 μs (def.)		
			001 _B 0.50 μs		
			010 _B 0.75 μs		
			011 _B 1.00 μs		
			100 _B 1.25 μs		
			101 _B 1.50 μs		
			110 _B 1.75 μs		
			111 _B 2.00 μs		
IDISCHG_ST	[4:0]	rw	Static discharge current of HB1 - HB3		
				IGx_SEL = 0 _B	IGx_SEL = 1 _B
			0 0000 _B	14.8 mA	15.8 mA
			0 0001 _B	21.3 mA	24.3 mA
			0 0010 _B	27.7 mA	32.7 mA
			0 0011 _B	34.3 mA	41.2 mA
			0 0100 _B	40.6 mA	49.7 mA
			0 0101 _B	47.1 mA	58.1 mA
			0 0110 _B	53.6 mA	66.6 mA
			0 0111 _B	60.0 mA	75.0 mA
			0 1000 _B	70.8 mA	89.3 mA
			0 1001 _B	81.5 mA	103.5 mA
			0 1010 _B	92.3 mA	117.8 mA

(table continues...)

Table 28 (continued) General control register 11 (000 1011_B) Reset value: 0000 1111_B

			0 1011 _B	103.0 mA	132.0 mA
			0 1100 _B	113.8 mA	146.3 mA
			0 1101 _B	124.5 mA	160.5 mA
			0 1110 _B	135.3 mA	174.8 mA
			0 1111 _B (def.)	146.0 mA	189.0 mA
			1 0000 _B	159.8 mA	206.6 mA
			1 0001 _B	173.5 mA	224.2 mA
			1 0010 _B	187.2 mA	241.9 mA
			1 0011 _B	210.0 mA	259.5 mA
			1 0100 _B	214.8 mA	277.1 mA
			1 0101 _B	228.5 mA	294.7 mA
			1 0110 _B	242.3 mA	312.3 mA
			1 0111 _B	256.0 mA	330.0 mA
			1 1000 _B	270.9 mA	348.8 mA
			1 1001 _B	285.8 mA	367.5 mA
			1 1010 _B	300.6 mA	386.2 mA
			1 1011 _B	315.5 mA	405.0 mA
			1 1100 _B	330.4 mA	423.8 mA
			1 1101 _B	345.3 mA	442.5 mA
			1 1110 _B	360.20 mA	461.3 mA
			1 1111 _B	375.0 mA	480.0 mA

9.2.12 General control register 12

Table 29 General control register 12 (000 1100_B) Reset value: 0001 1011_B

7	6	5	4	3	2	1	0
RES	IPREDISCHG _T_XT	TBLK			TCCP		
r	rw	rw			rw		

Field	Bits	Type	Description
RES	7	r	Reserved. Always read as 0

(table continues...)

Table 29 (continued) General control register 12 (000 1100_B) Reset value: 0001 1011_B

IPREDISCHG_T_XT	6	rw	Extended pre-discharge time 0 _B keep the pre-discharge time defined by IPREDISCHG_T (default) 1 _B extend the pre-discharge time to 300ns when IPREDISCHG_T = 00 _B 350 ns when IPREDISCHG_T = 01 _B 400 ns when IPREDISCHG_T = 10 _B 450 ns when IPREDISCHG_T = 11 _B
TBLK	[5:3]	rw	Blank time tBLANK for HB1 - HB3 000 _B 0.5 μs 001 _B 1.0 μs 010 _B 1.5 μs 011 _B 2.0 μs (def.) 100 _B 2.5 μs 101 _B 3.0 μs 110 _B 3.5 μs 111 _B 4.0 μs
TCCP	[2:0]	rw	Cross current protection tCCP for HB1 - HB3 000 _B 0.5 μs 001 _B 1.0 μs 010 _B 1.5 μs 011 _B 2.0 μs (def.) 100 _B 2.5 μs 101 _B 3.0 μs 110 _B 3.5 μs 111 _B 4.0 μs

9.2.13 General control register 13

Table 30 General control register 13 (000 1101_B) Reset value: 0000 0011_B

7	6	5	4	3	2	1	0
RES	LSAFW_CFG	LSAFW		VSMOV_CFG	VSM_COVUVTH		
r	rw	rw		rw	rw		

Field	Bits	Type	Description
RES	7	r	Reserved. Always read as 0
LSAFW_CFG	6	rw	Overvoltage low-side freewheeling enable bit 0 _B switch off MOSFETs if VSMOV = 1 (default) 1 _B activate low-side freewheeling if VSMOV = 1

(table continues...)

Table 30 (continued) General control register 13 (000 1101_B) Reset value: 0000 0011_B

LSAFW	[5:4]	rw	Low-side freewheeling set up bit: 00 _B all low-side MOSFETs are switched on for freewheeling if VSMOV = 1 (default) 01 _B only LS1 is switched on for freewheeling if VSMOV = 1 10 _B only LS2 is switched on for freewheeling if VSMOV = 1 11 _B only LS3 is switched on for freewheeling if VSMOV = 1
VSMOV_CFG	3	rw	Configurable overvoltage/undervoltage enable bit: 0 _B when VSM reaches VSM_COVUVTH, the VSMOV is set and the overvoltage event is reported in GEF (default) 1 _B when VSM reaches VSM_COVUVTH, the overvoltage event is ignored
VSM_COVUVTH	[2:0]	rw	Configurable overvoltage/undervoltage thresholds: 000 _B OV: 56 V, UV: 18.5 V 001 _B OV: 58 V, UV: 18.5 V 010 _B OV: 60 V, UV: 18.5 V 011 _B OV: 62 V, UV: 18.5 V (default) 100 _B OV: 51 V, UV: 7.0 V 101 _B keep the latest configuration settings 110 _B keep the latest configuration settings 111 _B keep the latest configuration settings

9.3 Status registers

- One 16-bit SPI command consists of two bytes (see [Figure 18](#)):
 - The 7-bit address and one additional bit for the register access mode and
 - Following the data byte
- There are two different bit types:
 - 'r' = READ: read only bits (or reserved bits)
 - 'rc' = READ/CLEAR: readable and clearable bits
- Reading a register is done word wise by setting the SPI bit OP to 0 (= read only)
- Clearing a register is done word wise by setting the SPI bit OP to 1. No single bits can be cleared
- The SPI status registers are in general not cleared automatically. It must be done by the microcontroller via SPI command

Table 31 General control register 14 (010 1011_B) Reset value: 0000 0000_B

7	6	5	4	3	2	1	0
RES	RES	RES	RES	RES	BEMF_PROC ESSING_EN	BEMF_BT_TFILT_SEL	
r	r	r	r	r	rw	rw	

Field	Bits	Type	Description
RES	7	r	Reserved. Always read as 0

(table continues...)

Table 31 (continued) General control register 14 (010 1011B) Reset value: 0000 0000B

RES	6	r	Reserved. Always read as 0
RES	5	r	Reserved. Always read as 0
RES	4	r	Reserved. Always read as 0
RES	3	r	Reserved. Always read as 0
BEMF_PROCESSING_EN	2	rw	BEMF processing enable bit: 0 _B BEMF processing algorithm is disabled (default) 1 _B BEMF processing algorithm is enabled
BEMF_BT_TFILT_SEL	[1:0]	rw	HB Blanking time for BEMF comparator output signal 00 _B 6 μs (default) 01 _B 8 μs 10 _B 12 μs 11 _B 16 μs

9.3.1 General status register

Table 32 General status register (000 1110_B) Reset value: 0000 0000_B

7	6	5	4	3	2	1	0
RES	DSOV	SUPE	INE	TE	nPOR	ST	SPIE
r	r	r	r	r	rc	rc	rc

Field	Bits	Type	Description
RES	7	r	Reserved. Always read as 0
DSOV	6	r	VDS monitoring bit 0 _B no VDS error is detected (default) 1 _B VDS error is detected
SUPE	5	r	Supply error bit 0 _B no supply error is detected (default) 1 _B supply error is detected
INE	4	r	Input error bit 0 _B no input error is detected (default) 1 _B input error is detected
TE	3	r	Temperature error bit 0 _B no thermal shutdown and no thermal warning is detected (default) 1 _B a thermal shutdown or a thermal warning is detected
nPOR	2	rc	Negative Power-On-Reset bit 0 _B a Power-On-Reset is detected (default) 1 _B no Power-On-Reset (after clear)

(table continues...)

Table 32 (continued) **General status register (000 1110_B) Reset value: 0000 0000_B**

ST	1	rc	Stop mode bit 0 _B The device is not in stop mode state (default) 1 _B The device is in stop mode state
SPIE	0	rc	SPI protocol error bit 0 _B No SPI protocol error is detected (default) 1 _B A SPI protocol error is detected

9.3.2 Global status register 1

Table 33 **Global status register 1 (000 1111_B) Reset value: 0000 0000_B**

7	6	5	4	3	2	1	0
RES	TW	TSD	CP1UV	CP2UV	VSMOV_PRO T	VSMOV	VSMUV
rc	rc	rc	rc	rc	rc	rc	rc

Field	Bits	Type	Description
RES	7	rc	Reserved. Always read as 0
TW	6	rc	Thermal warning 0 _B no thermal warning is detected (default) 1 _B a thermal warning is detected
TSD	5	rc	Thermal shutdown 0 _B no thermal shutdown is detected (default) 1 _B a thermal shutdown is detected
CP1UV	4	rc	Charge pump 1 undervoltage 0 _B no charge pump 1 undervoltage detected (default) 1 _B charge pump 1 undervoltage detected
CP2UV	3	rc	Charge pump 2 undervoltage 0 _B no charge pump 2 undervoltage detected (default) 1 _B charge pump 2 undervoltage detected
VSMOV_PRO T	2	rc	VSM overvoltage Bit 0 _B VSM doesn't reach the hard OV threshold (default) 1 _B VSM reaches the hard OV threshold
VSMOV	1	rc	VSM overvoltage Bit 0 _B no VSM Overvoltage is detected (default) 1 _B VSM Overvoltage is detected
VSMUV	0	rc	VSM undervoltage Bit 0 _B no VSM Undervoltage is detected (default) 1 _B VSM Undervoltage is detected

9.3.3 Global status register 2

Table 34 Global status register 2 (001 0000_B) Reset value: 0000 0000_B

7	6	5	4	3	2	1	0
WDMON		LS3DSOV	HS3DSOV	LS2DSOV	HS2DSOV	LS1DSOV	HS1DSOV
r		rc	rc	rc	rc	rc	rc

Field	Bits	Type	Description
WDMON	[7:6]	r	Watchdog monitoring 00 _B WD timer is between [0%;25%] of the WD period (default) 01 _B WD timer is between [25%;50%] of the WD period 10 _B WD timer is between [50%;75%] of the WD period 11 _B WD timer is between [75%;100%] of the WD period
LS3DSOV	5	rc	Drain-source overvoltage on low side 3 0 _B no overvoltage on DS of low side 3 (default) 1 _B overvoltage on DS of low side 3 is detected
HS3DSOV	4	rc	Drain-source overvoltage on high side 3 0 _B no overvoltage on DS of high side 3 (default) 1 _B overvoltage on DS of high side 3 is detected
LS2DSOV	3	rc	Drain-source overvoltage on low side 2 0 _B no overvoltage on DS of low side 2 (default) 1 _B overvoltage on DS of low side 2 is detected
HS2DSOV	2	rc	Drain-source overvoltage on high side 2 0 _B no overvoltage on DS of high side 2 (default) 1 _B overvoltage on DS of high side 2 is detected
LS1DSOV	1	rc	Drain-source overvoltage on low side 1 0 _B no overvoltage on DS of low side 1 (default) 1 _B overvoltage on DS of low side 1 is detected
HS1DSOV	0	rc	Drain-source overvoltage on high side 1 0 _B no overvoltage on DS of high side 1 (default) 1 _B overvoltage on DS of high side 1 is detected

9.3.4 Global status register 3

Table 35 Global status register 3 (001 0001_B) Reset value: 0000 0000_B

7	6	5	4	3	2	1	0
RES	RES	INE1	INE2	INE3	HS3VOUT	HS2VOUT	HS1VOUT
r	r	rc	rc	rc	r	r	r

Filed	Bits	Type	Description
-------	------	------	-------------

(table continues...)

Table 35 (continued) Global status register 3 (001 0001_B) Reset value: 0000 0000_B

RES	[7:6]	r	Reserved. Always read as 0
INE1	5	rc	Input 1 error 0 _B no input 1 error is detected (default) 1 _B IH1 and IL1 are high
INE2	4	rc	Input 2 error 0 _B no input 2 error is detected (default) 1 _B IH2 and IL2 are high
INE3	3	rc	Input 3 error 0 _B no input 1 error is detected (default) 1 _B IH3 and IL3 are high
HS3VOUT	2	r	Voltage level at SH3 when (IH3, IL3) = (0,0) 0 _B low: VSH3 - GND < VSHL 1 _B high: VSH3 - GND > VSHL Note: HB3VOUT = 0 if (IH3, IL3) = (1,0) or (0,1).
HS2VOUT	1	r	Voltage level at SH2 when (IH2, IL2) = (0,0) 0 _B low: VSH2 - GND < VSHL 1 _B high: VSH2 - GND > VSHL Note: HB2VOUT = 0 if (IH2, IL2) = (1,0) or (0,1).
HS1VOUT	0	r	Voltage level at SH1 when (IH1, IL1) = (0,0) 0 _B low: VSH1 - GND < VSHL 1 _B high: VSH1 - GND > VSHL Note: HB1VOUT = 0 if (IH1, IL1) = (1,0) or (0,1).

9.3.5 Global status register 4

Table 36 Global status register 4 (001 0010_B) Reset value: 0000 0000_B

7	6	5	4	3	2	1	0
RES					BEMF3	BEMF2	BEMF1
r					r	r	r

Field	Bits	Type	Description
RES	[7:3]	r	Reserved. Always read as 0

(table continues...)

Table 36 (continued) Global status register 4 (001 0010_B) Reset value: 0000 0000_B

BEMF3	2	r	<p>Signal for BEMF3 $1_B \text{ VSHM3} > (\text{VSHM1} + \text{VSHM2})/2$ $0_B \text{ VSHM3} < (\text{VSHM1} + \text{VSHM2})/2$</p> <p>Note: If the BEMF_POCESSING_EN bit is set to 0_B, the BEMF3 will be real time signal. If the BEMF_POCESSING_EN bit is set to 1_B, the BEMF3 will be the output signal with the post-processing algorithm. When BD_EN = 0_B, the BEMF3 = 0_B</p>
BEMF2	1	r	<p>Signal for BEMF2 $1_B \text{ VSHM2} > (\text{VSHM1} + \text{VSHM3})/2$ $0_B \text{ VSHM2} < (\text{VSHM1} + \text{VSHM3})/2$</p> <p>Note: If the BEMF_POCESSING_EN bit is set to 0_B, the BEMF2 will be real time signal. If the BEMF_POCESSING_EN bit is set to 1_B, the BEMF2 will be the output signal with the post-processing algorithm. When BD_EN = 0_B, the BEMF2 = 0_B</p>
BEMF1	0	r	<p>Signal for BEMF1 $1_B \text{ VSHM1} > (\text{VSHM2} + \text{VSHM3})/2$ $0_B \text{ VSHM1} < (\text{VSHM2} + \text{VSHM3})/2$</p> <p>Note: If the BEMF_POCESSING_EN bit is set to 0_B, the BEMF1 will be real time signal. If the BEMF_POCESSING_EN bit is set to 1_B, the BEMF1 will be the output signal with the post-processing algorithm. When BD_EN = 0_B, the BEMF1 = 0_B</p>

9.3.6 Effective MOSFET turn-on/-off delay

Table 37 Effective high-side MOSFET turn-on delay PWM1 (001 0011_B) Reset value: 0000 0000_B

7	6	5	4	3	2	1	0
TDONHS1							
r							

Field	Bits	Type	Description
-------	------	------	-------------

(table continues...)

Table 37 (continued) **Effective high-side MOSFET turn-on delay PWM1 (001 0011_B) Reset value: 0000 0000_B**

TDONHS1	[7:0]	r	Effective high-side MOSFET turn-on delay of PWM channel 1 ¹⁾ HBFREQ bit is 1: effective turn-on delay = 53.3 * TDONHS1[7:0] _D ns HBFREQ bit is 0: effective turn-on delay = 26.7 * TDONHS1[7:0] _D ns Default value: 0 _B
----------------	-------	---	---

Table 38 **Effective high-side MOSFET turn-off delay PWM1 (001 0100_B) Reset value: 0000 0000_B**

7	6	5	4	3	2	1	0
TDOFFHS1							
r							

Field	Bits	Type	Description
TDOFFHS1	[7:0]	r	Effective high-side MOSFET turn-off delay of PWM channel 1 ³⁾ HBFREQ bit is 1: effective turn-off delay = 53.3 * TDOFFHS1[7:0] _D ns HBFREQ bit is 0: effective turn-off delay = 26.7 * TDOFFHS1[7:0] _D ns Default value: 0 _B

Table 39 **Effective low-side MOSFET turn-on delay PWM1 (001 0101_B) Reset value: 0000 0000_B**

7	6	5	4	3	2	1	0
TDONLS1							
r							

Field	Bits	Type	Description
TDONLS1	[7:0]	r	Effective low-side MOSFET turn-on delay of PWM channel 1 ²⁾ HBFREQ bit is 1: effective turn-on delay = 53.3 * TDONLS1[7:0] _D ns HBFREQ bit is 0: effective turn-on delay = 26.7 * TDONLS1[7:0] _D ns Default value: 0 _B

Table 40 **Effective low-side MOSFET turn-off delay PWM1 (001 0110_B) Reset value: 0000 0000_B**

7	6	5	4	3	2	1	0
TDOFFLS1							
r							

Field	Bits	Type	Description
TDOFFLS1	[7:0]	r	Effective low-side MOSFET turn-off delay of PWM channel 1 ⁴⁾ HBFREQ bit is 1: effective turn-off delay = 53.3 * TDOFFLS1[7:0] _D ns HBFREQ bit is 0: effective turn-off delay = 26.7 * TDOFFLS1[7:0] _D ns Default value: 0 _B

Table 41 Effective high-side MOSFET turn-on delay PWM2 (001 0111_B) Reset value: 0000 0000_B

7	6	5	4	3	2	1	0
TDONHS2							
r							

Field	Bits	Type	Description
TDONHS2	[7:0]	r	Effective high-side MOSFET turn-on delay of PWM channel 2 ¹⁾ HBFREQ bit is 1: effective turn-on delay = $53.3 * TDONHS2[7:0]_D$ ns HBFREQ bit is 0: effective turn-on delay = $26.7 * TDONHS2[7:0]_D$ ns Default value: 0 _B

Table 42 Effective high-side MOSFET turn-off delay PWM2 (001 1000_B) Reset value: 0000 0000_B

7	6	5	4	3	2	1	0
TDOFFHS2							
r							

Field	Bits	Type	Description
TDOFFHS2	[7:0]	r	Effective high-side MOSFET turn-off delay of PWM channel 2 ³⁾ HBFREQ bit is 1: effective turn-off delay = $53.3 * TDOFFHS2[7:0]_D$ ns HBFREQ bit is 0: effective turn-off delay = $26.7 * TDOFFHS2[7:0]_D$ ns Default value: 0 _B

Table 43 Effective low-side MOSFET turn-on delay PWM2 (001 1001_B) Reset value: 0000 0000_B

7	6	5	4	3	2	1	0
TDONLS2							
r							

Field	Bits	Type	Description
TDONLS2	[7:0]	r	Effective low-side MOSFET turn-on delay of PWM channel 2 ²⁾ HBFREQ bit is 1: effective turn-on delay = $53.3 * TDONLS2[7:0]_D$ ns HBFREQ bit is 0: effective turn-on delay = $53.3 * 127 + 26.7 * TDONLS2[7:0]_D$ ns Default value: 0 _B

Table 44 Effective low-side MOSFET turn-off delay PWM2 (001 1010_B) Reset value: 0000 0000_B

7	6	5	4	3	2	1	0
TDOFFLS2							
r							

(table continues...)

Table 44 (continued) **Effective low-side MOSFET turn-off delay PWM2 (001 1010_B) Reset value: 0000 0000_B**

Field	Bits	Type	Description
TDOFFLS2	[7:0]	r	Effective low-side MOSFET turn-off delay of PWM channel 2 ⁴⁾ HBFREQ bit is 1: effective turn-off delay = $53.3 * TDOFFLS2[7:0]_D$ ns HBFREQ bit is 0: effective turn-off delay = $26.7 * TDOFFLS2[7:0]_D$ ns Default value: 0 _B

Table 45 **Effective high-side MOSFET turn-on delay PWM3 (001 1011_B) Reset value: 0000 0000_B**

7	6	5	4	3	2	1	0
TDONHS3							
r							

Field	Bits	Type	Description
TDONHS3	[7:0]	r	Effective high-side MOSFET turn-on delay of PWM channel 3 ¹⁾ HBFREQ bit is 1: effective turn-on delay = $53.3 * TDONHS3[7:0]_D$ ns HBFREQ bit is 0: effective turn-on delay = $26.7 * TDONHS3[7:0]_D$ ns Default value: 0 _B

Table 46 **Effective high-side MOSFET turn-off delay PWM3 (001 1100_B) Reset value: 0000 0000_B**

7	6	5	4	3	2	1	0
TDOFFHS3							
r							

Field	Bits	Type	Description
TDOFFHS3	[7:0]	r	Effective high-side MOSFET turn-off delay of PWM channel 3 ³⁾ HBFREQ bit is 1: effective turn-off delay = $53.3 * TDOFFHS3[7:0]_D$ ns HBFREQ bit is 0: effective turn-off delay = $26.7 * TDOFFHS3[7:0]_D$ ns Default value: 0 _B

Table 47 **Effective low-side MOSFET turn-on delay PWM3 (001 1101_B) Reset value: 0000 0000_B**

7	6	5	4	3	2	1	0
TDONLS3							
r							

Field	Bits	Type	Description
-------	------	------	-------------

(table continues...)

Table 47 (continued) **Effective low-side MOSFET turn-on delay PWM3 (001 1101_B) Reset value: 0000 0000_B**

TDONLS3	[7:0]	r	Effective low-side MOSFET turn-on delay of PWM channel 3 ²⁾ HBFREQ bit is 1: effective turn-on delay = 53.3 * TDONLS3[7:0] _D ns HBFREQ bit is 0: effective turn-on delay = 26.7 * TDONLS3[7:0] _D ns Default value: 0 _B
----------------	-------	---	--

Table 48 **Effective low-side MOSFET turn-off delay PWM3 (001 1110_B) Reset value: 0000 0000_B**

7	6	5	4	3	2	1	0
TDOFFLS3							
r							

Field	Bits	Type	Description
TDOFFLS3	[7:0]	r	Effective low-side MOSFET turn-off delay of PWM channel 3 ⁴⁾ HBFREQ bit is 1: effective turn-off delay = 53.3 * TDOFFLS3[7:0] _D ns HBFREQ bit is 0: effective turn-off delay = 26.7 * TDOFFLS3[7:0] _D ns Default value: 0 _B

- 1) Effective high-side turn-on delay is reported if VSHM_x rises above VSHL in the duration of TBLANK.
If VSHM_x > VSHL when the precharge starts, TDONHS_x will be set to 0000 0000_B.
If VSHM_x < VSHL when TBLANK elapses, TDONHS_x will be set to 1111 1111_B.
- 2) Effective low-side turn-on delay is reported if VSHM_x drops below VSHH in the duration of TBLANK.
If VSHM_x < VSHH when the precharge starts, TDONLS_x will be set to 0000 0000_B.
If VSHM_x > VSHH when TBLANK elapses, TDONLS_x will be set to 1111 1111_B.
- 3) Effective high-side turn-off delay is reported if VSHM_x drops below VSHH in the duration of TCCP.
If VSHM_x > VSHH when TCCP elapses, TDOFFHS_x will be set to 1111 1111_B.
If VSHM_x < VSHH when the predischarge starts, TDOFFHS_x will be set to 0000 0000_B.
- 4) Effective low-side turn-off delay is reported if VSHM_x rises above VSHL in the duration of TCCP.
If VSHM_x < VSHL when TCCP elapses, TDOFFLS_x will be set to 1111 1111_B.
If VSHM_x > VSHL when the predischarge starts, TDOFFLS_x will be set to 0000 0000_B.

9.3.7 Effective MOSFET rise/fall times

Table 49 **Effective high-side MOSFET rise time of PWM1 (001 1111_B) Reset value: 0000 0000_B**

7	6	5	4	3	2	1	0
TRISEHS1							
r							

Field	Bits	Type	Description
-------	------	------	-------------

(table continues...)

Table 49 (continued) **Effective high-side MOSFET rise time of PWM1 (001 1111_B) Reset value: 0000 0000_B**

TRISEHS1	[7:0]	r	Effective high-side MOSFET rise time of PWM channel 1 ¹⁾ HBFREQ bit is 1: effective rise time = 53.3 * TRISE_HS1[7:0] _D ns HBFREQ bit is 0: effective rise time = 26.7 * TRISE_HS1[7:0] _D ns Default value: 0 _B
-----------------	-------	---	---

Table 50 **Effective high-side MOSFET fall time of PWM1 (010 0000_B) Reset value: 0000 0000_B**

7	6	5	4	3	2	1	0
TFALLHS1							
r							

Field	Bits	Type	Description
TFALLHS1	[7:0]	r	Effective high-side MOSFET fall time of PWM channel 1 ³⁾ HBFREQ bit is 1: effective fall time = 53.3 * TFALL_HS1[7:0] _D ns HBFREQ bit is 0: effective fall time = 26.7 * TFALL_HS1[7:0] _D ns Default value: 0 _B

Table 51 **Effective low-side MOSFET rise time of PWM1 (010 0001_B) Reset value: 0000 0000_B**

7	6	5	4	3	2	1	0
TRISELS1							
r							

Field	Bits	Type	Description
TRISELS1	[7:0]	r	Effective low-side MOSFET rise time of PWM channel 1 ²⁾ HBFREQ bit is 1: effective rise time = 53.3 * TRISE_LS1[7:0] _D ns HBFREQ bit is 0: effective rise time = 26.7 * TRISE_LS1[7:0] _D ns Default value: 0 _B

Table 52 **Effective low-side MOSFET fall time of PWM1 (010 0010_B) Reset value: 0000 0000_B**

7	6	5	4	3	2	1	0
TFALLLS1							
r							

Field	Bits	Type	Description
TFALLLS1	[7:0]	r	Effective low-side MOSFET fall time of PWM channel 1 ⁴⁾ HBFREQ bit is 1: effective fall time = 53.3 * TFALL_LS1[7:0] _D ns HBFREQ bit is 0: effective fall time = 26.7 * TFALL_LS1[7:0] _D ns Default value: 0 _B

Table 53 Effective high-side MOSFET rise time of PWM2 (010 0011_B) Reset value: 0000 0000_B

7	6	5	4	3	2	1	0
TRISEHS2							
r							

Field	Bits	Type	Description
TRISEHS2	[7:0]	r	Effective high-side MOSFET rise time of PWM channel 2 ¹⁾ HBFREQ bit is 1: effective rise time = 53.3 * TRISE_HS2[7:0] _D ns HBFREQ bit is 0: effective rise time = 26.7 * TRISE_HS2[7:0] _D ns Default value: 0 _B

Table 54 Effective high-side MOSFET fall time of PWM2 (010 0100_B) Reset value: 0000 0000_B

7	6	5	4	3	2	1	0
TFALLHS2							
r							

Field	Bits	Type	Description
TFALLHS2	[7:0]	r	Effective high-side MOSFET fall time of PWM channel 2 ³⁾ HBFREQ bit is 1: effective fall time = 53.3 * TFALL_HS2[7:0] _D ns HBFREQ bit is 0: effective fall time = 26.7 * TFALL_HS2[7:0] _D ns Default value: 0 _B

Table 55 Effective low-side MOSFET rise time of PWM2 (010 0101_B) Reset value: 0000 0000_B

7	6	5	4	3	2	1	0
TRISELS2							
r							

Field	Bits	Type	Description
TRISELS2	[7:0]	r	Effective low-side MOSFET rise time of PWM channel 2 ²⁾ HBFREQ bit is 1: effective rise time = 53.3 * TRISE_LS2[7:0] _D ns HBFREQ bit is 0: effective rise time = 26.7 * TRISE_LS2[7:0] _D ns Default value: 0 _B

Table 56 Effective low-side MOSFET fall time of PWM2 (010 0110_B) Reset value: 0000 0000_B

7	6	5	4	3	2	1	0
TFALLLS2							
r							

Field	Bits	Type	Description
-------	------	------	-------------

(table continues...)
Datasheet

Table 56 (continued) **Effective low-side MOSFET fall time of PWM2 (010 0110_B)** Reset value: 0000 0000_B

TFALLLS2	[7:0]	r	Effective low-side MOSFET fall time of PWM channel 2 ⁴⁾ HBFREQ bit is 1: effective fall time = 53.3 * TFALL_LS2[7:0] _D ns HBFREQ bit is 0: effective fall time = 26.7 * TFALL_LS2[7:0] _D ns Default value: 0 _B
-----------------	-------	---	--

Table 57 **Effective high-side MOSFET rise time of PWM3 (010 0111_B)** Reset value: 0000 0000_B

7	6	5	4	3	2	1	0
TRISEHS3							
r							

Field	Bits	Type	Description
TRISEHS3	[7:0]	r	Effective high-side MOSFET rise time of PWM channel 3 ¹⁾ HBFREQ bit is 1: effective rise time = 53.3 * TRISE_HS3[7:0] _D ns HBFREQ bit is 0: effective rise time = 26.7 * TRISE_HS3[7:0] _D ns Default value: 0 _B

Table 58 **Effective high-side MOSFET fall time of PWM3 (010 1000_B)** Reset value: 0000 0000_B

7	6	5	4	3	2	1	0
TFALLHS3							
r							

Field	Bits	Type	Description
TFALLHS3	[7:0]	r	Effective high-side MOSFET fall time of PWM channel 3 ³⁾ HBFREQ bit is 1: effective fall time = 53.3 * TFALL_HS3[7:0] _D ns HBFREQ bit is 0: effective fall time = 26.7 * TFALL_HS3[7:0] _D ns Default value: 0 _B

Table 59 **Effective low-side MOSFET rise time of PWM3 (010 1001_B)** Reset value: 0000 0000_B

7	6	5	4	3	2	1	0
TRISELS3							
r							

Field	Bits	Type	Description
TRISELS3	[7:0]	r	Effective low-side MOSFET rise time of PWM channel 3 ²⁾ HBFREQ bit is 1: effective rise time = 53.3 * TRISE_LS3[7:0] _D ns HBFREQ bit is 0: effective rise time = 26.7 * TRISE_LS3[7:0] _D ns Default value: 0 _B

Table 60 **Effective low-side MOSFET fall time of PWM3 (010 1010_B) Reset value: 0000 0000_B**

7	6	5	4	3	2	1	0
TFALLS3							
r							

Field	Bits	Type	Description
TFALLS3	[7:0]	r	Effective low-side MOSFET fall time of PWM channel 3 ⁴⁾ HBFREQ bit is 1: effective fall time = 53.3 * TFALL_LS3[7:0] _D ns HBFREQ bit is 0: effective fall time = 26.7 * TFALL_LS3[7:0] _D ns Default value: 0 _B

- 1) Effective high-side rise time is reported if VSHM_x rises above VSHH in the duration of TBLANK.
 If VSHM_x > VSHH when the precharge starts, TRISE_HS_x will be set to 0000 0000_B.
 If VSHL < VSHM_x < VSHH when TBLANK elapses, TRISE_HS_x will be set to 1111 1111_B.
- 2) Effective low-side rise time is reported if VSHM_x drops below VSHL in the duration of TBLANK.
 If VSHM_x < VSHL when the precharge starts, TRISE_LS_x will be set to 0000 0000_B.
 If VSHL < VSHM_x < VSHH when TBLANK elapses, TRISE_LS_x will be set to 1111 1111_B.
- 3) Effective high-side fall time is reported if VSHM_x drops below VSHL in the duration of TCCP.
 If VSHH > VSHM_x > VSHL when TCCP elapses, TFALL_HS_x will be set to 1111 1111_B.
 If VSHM_x < VSHL when the predischarge starts, TFALL_HS_x will be set to 0000 0000_B.
- 4) Effective low-side fall time is reported if VSHM_x rises above VSHH in the duration of TCCP.
 If VSHH < VSHM_x < VSHL when TCCP elapses, TFALL_LS_x will be set to 1111 1111_B.
 If VSHM_x > VSHH when the predischarge starts, TFALL_LS_x will be set to 0000 0000_B.

10 Application figure

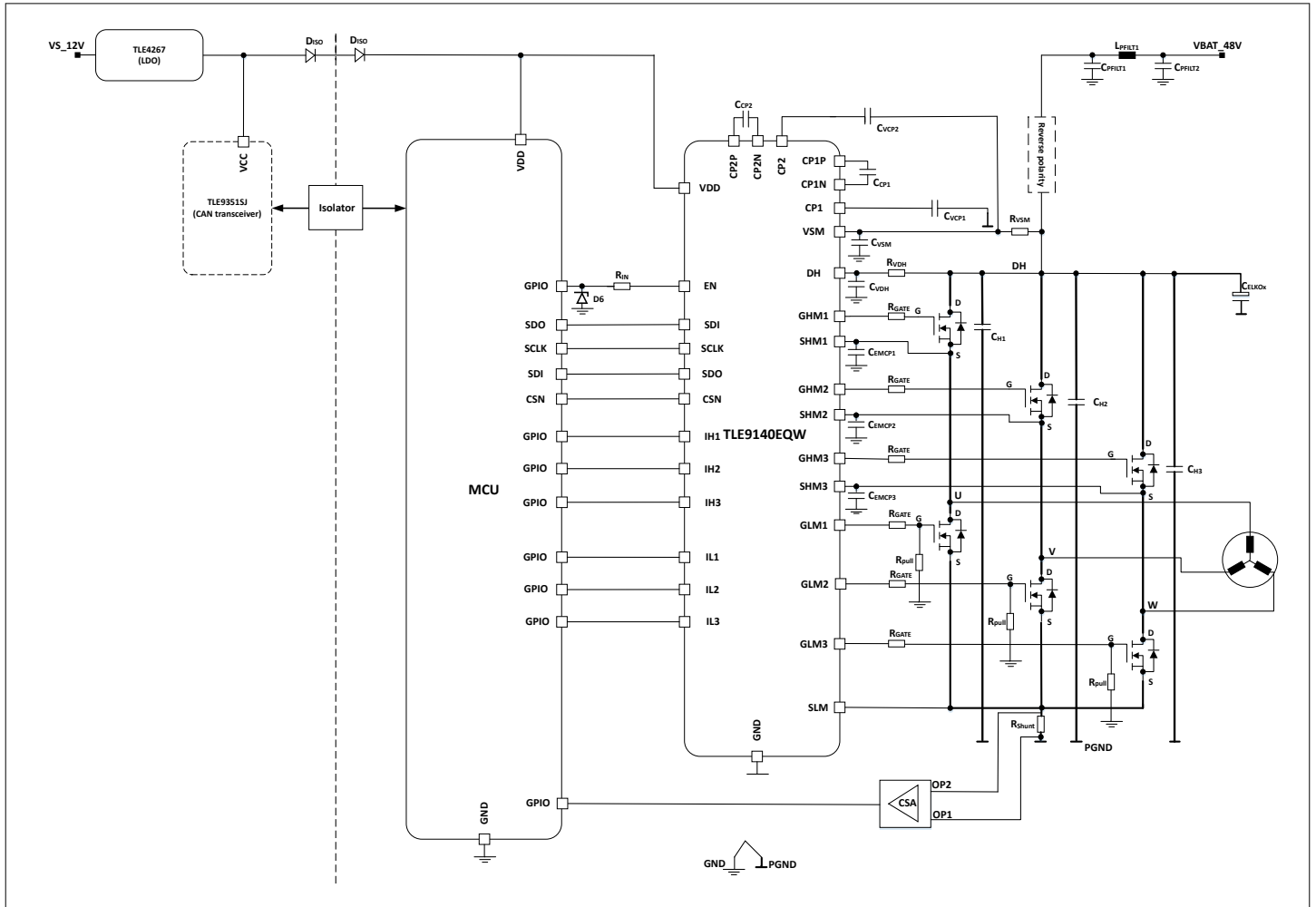

Figure 23 TLE9140EQW is driven by the general microcontroller for 48 V applications supply concept: isolated 12 V supply for the general MCU with diodes

10 Application figure

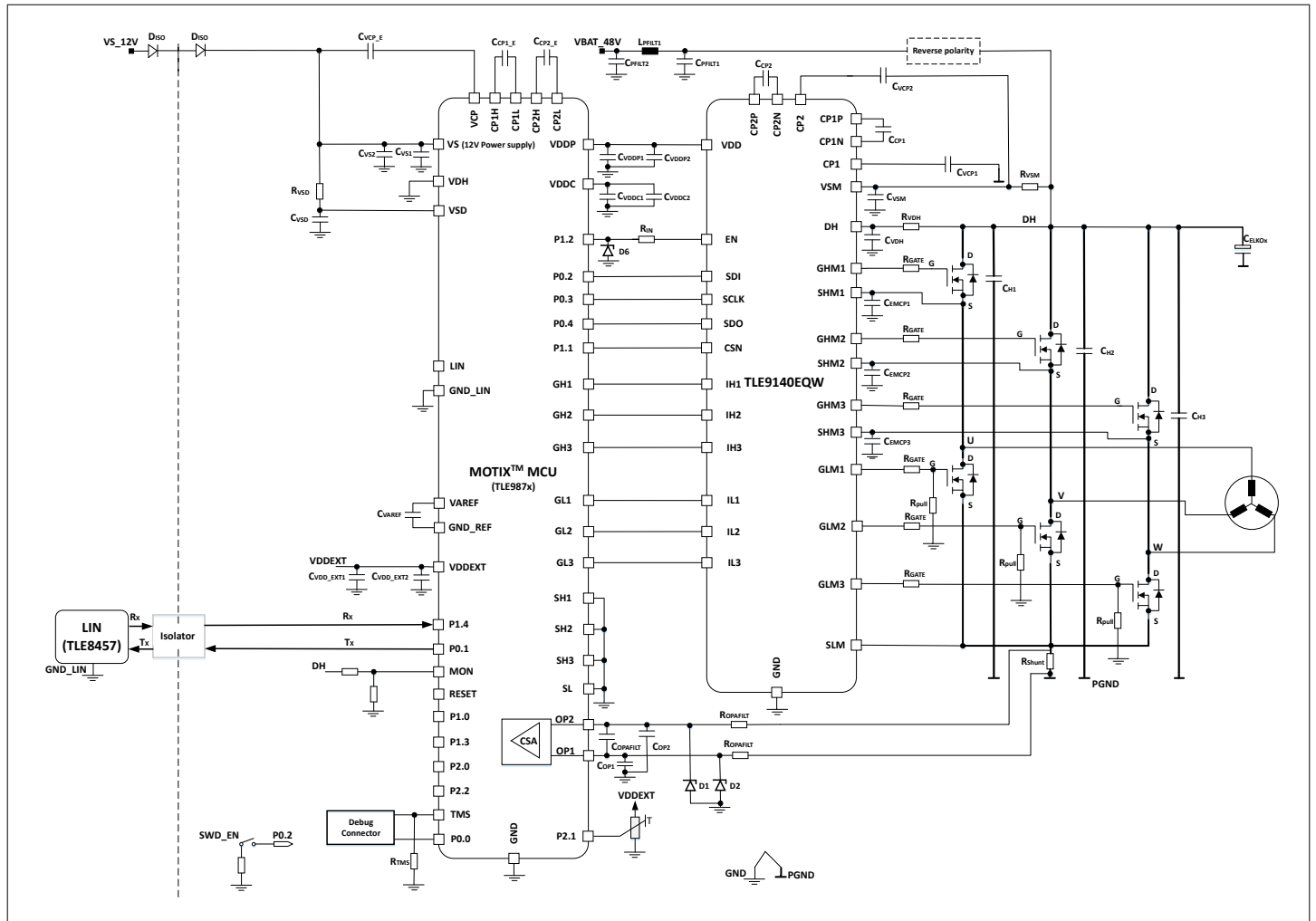

Figure 24 TLE9140EQW is driven by the MOTIX™ MCU (TLE987x) device supply concept: isolated 12 V supply for the MOTIX™ MCU device with diodes

10 Application figure

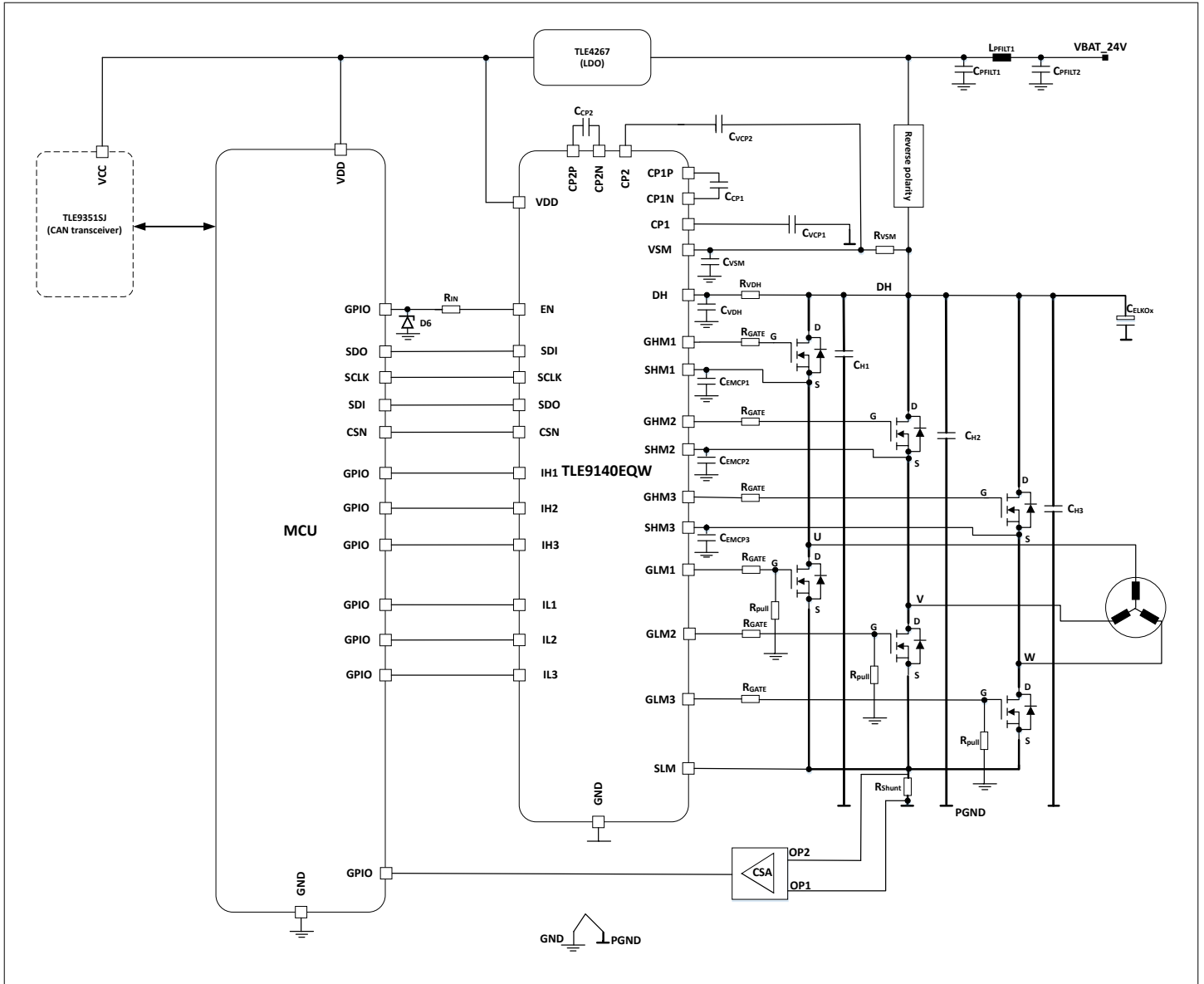

Figure 25 TLE9140EQW is driven by the general MCU for 24 V applications

10 Application figure

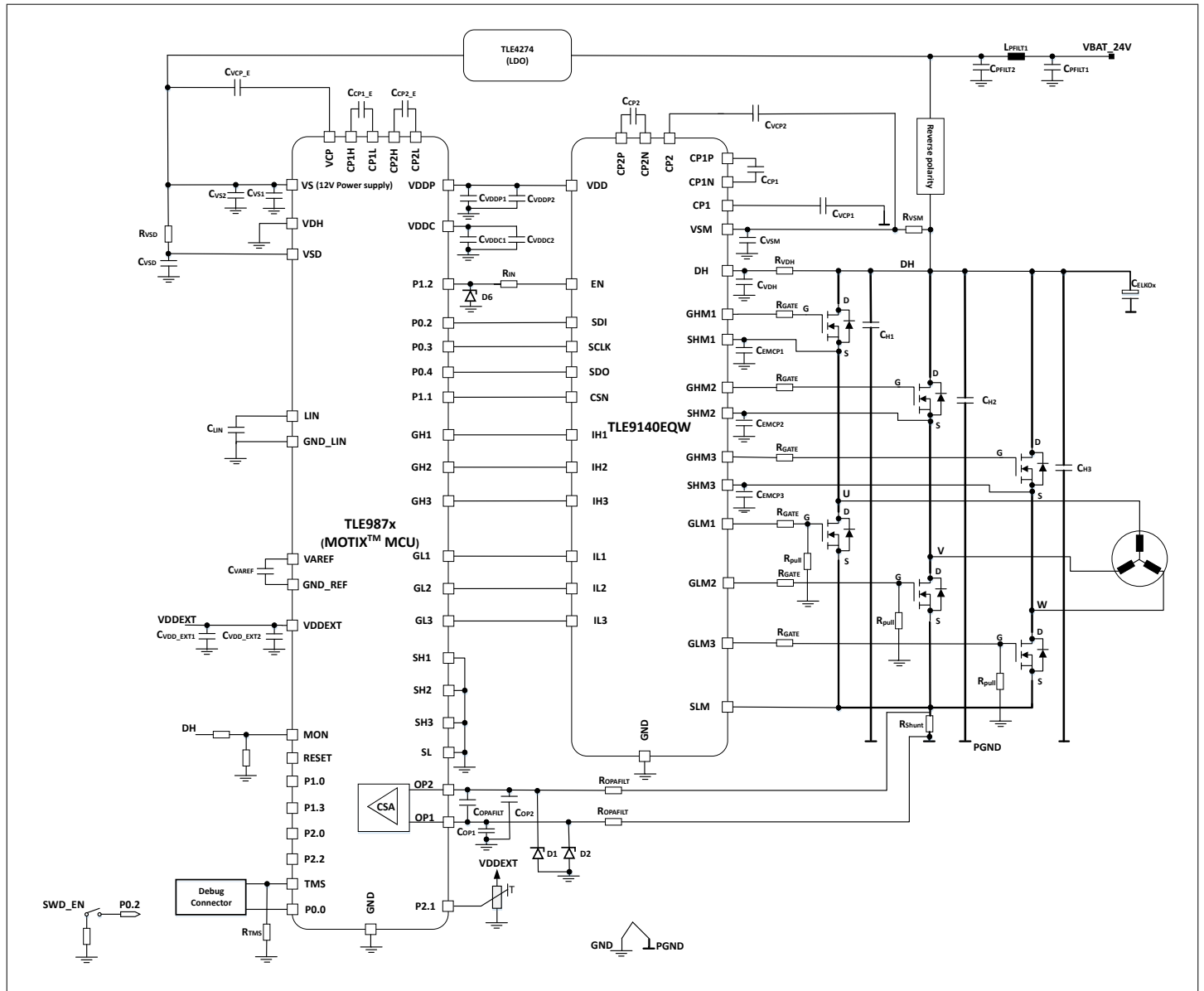

Figure 26 TLE9140EQW is driven by the MOTIX™ MCU (TLE987x) device for 24 V applications

11 Package outline

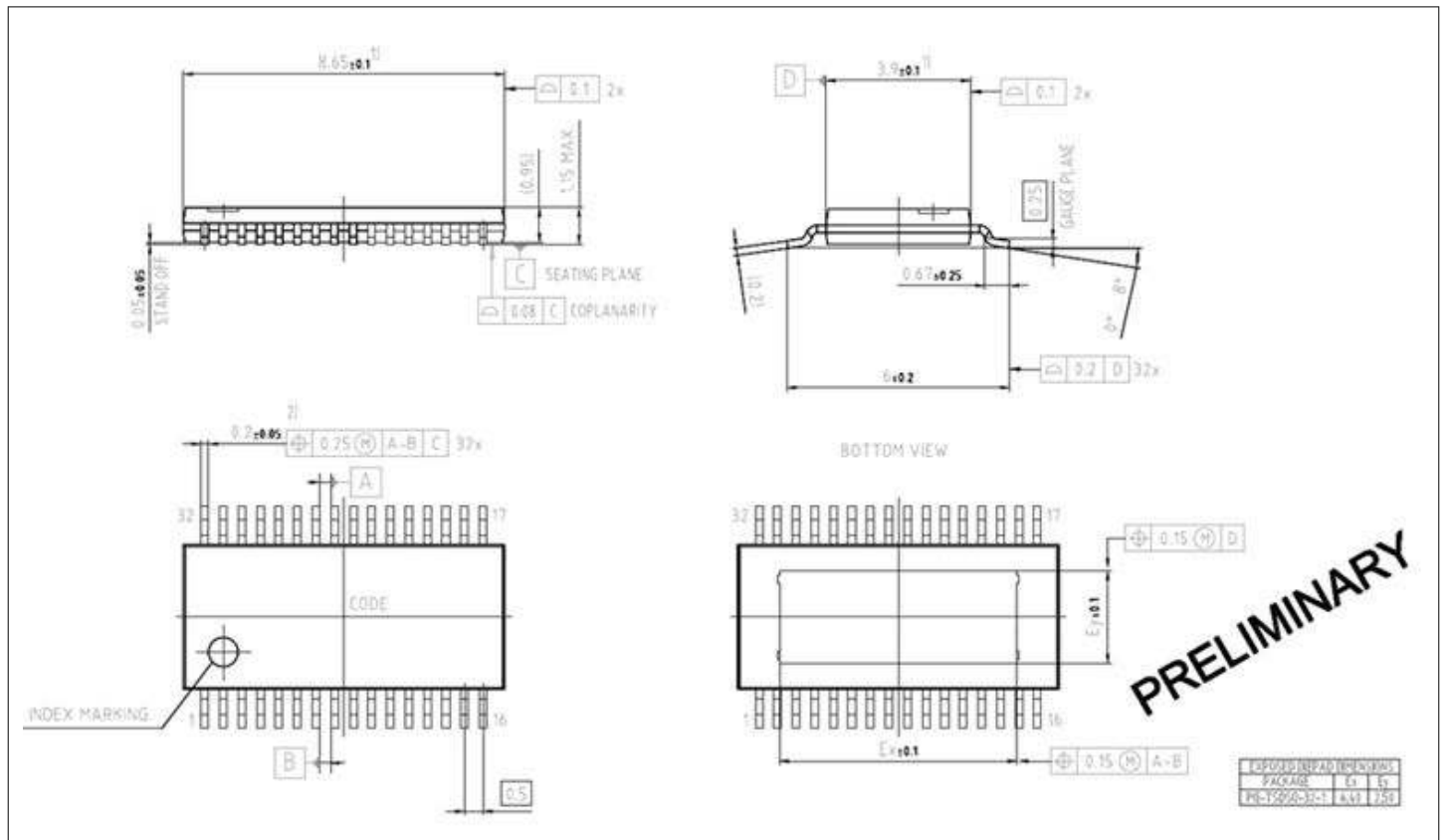

Figure 27 TSDSO-32

To meet the world-wide customer requirements for environmental friendly products and to be compliant with government regulations the device is available as a green product. Green products are RoHS-Compliant (this means lead-free finish on leads and suitable for Pb-free soldering according to IPC/JEDEC J-STD-020).

12 Revision history

Revision number	Date of release	Description of changes
Rev. 0.05	2022-10-04	<ul style="list-style-type: none"> • Update the logic supply currents I_{DD1} and I_{DD2} • Update the SHMx high threshold voltage V_{SHMH} • Update the SHMx low threshold voltage V_{SHML} • Update the undervoltage threshold of CP2 V_{CP2UV} • Update the BEMF hysteresis V_{BEMF_HYS} • Update the BEMF accuracy V_{BEMF_ACC} • Update the symbol of the on resistance of gate current source • Update the description in features and potential applications • Add application figure of TLE9140EQW controlled by general microcontroller • Replace Embedded power with MOTIX™ MCU • Update the cover page of the datasheet • Split current accuracy for the normal and boosted current for high current range.
Rev. 0.04	2022-04-20	<ul style="list-style-type: none"> • Update the GHMx vs. SHMx voltage V_{GSHMx} • Update the GLMx vs. SLMx voltage V_{GSLMx} • Update the logic supply currents I_{SM_NOR1}, I_{SM_NOR2} and I_{SM_NOR3} • Add BEMF accuracy and BEMF hysteresis • Update the pull-up diagnosis current I_{PUDiag} • Update the max. rating of V_{GHMx} and V_{SHMx} • Update the BEMF polarity in Global Status Register 4 • Update Drain-source overvoltage threshold • Update the typ. values of all charge/discharge currents in registers • Update the on resistance of the gate current source R_{ONGH}

Revision number	Date of release	Description of changes
Rev. 0.03	2021-12-06	<ul style="list-style-type: none"> • Update the max. rating of the supply voltage V_{SM} • Update the max. rating of charge pump pins • Update thermal resistance: R_{thJC} and R_{thJA} • Update quiescent current in chapter 4.4 • Update the sleep mode delay t_{DSLEEP} • Update the supply current I_{SM_NOR2} • Update the hard overvoltage switch on/off voltages: V_{SMOV_ON} and V_{SMOV_OFF} • Update the enable hysteresis V_{ENHY} • Update the values and conditions of charge pump outputs in Table 8 • Update charge pump 1 undervoltage threshold V_{CP1UV} • Update charge pump 2 undervoltage threshold V_{CP2UV} • Update Drain-source overvoltage threshold • Update the pull-up diagnosis current I_{PUDiag} • Update the pull-down diagnosis current I_{PDDiag} • Update the values and conditions of the output voltage in chapter 6.2 • Update the charge/discharge current accuracy • Update the Discharge_ST current accuracy • Update the SHMx high/low threshold • Add an on resistance of gate current source • Update the description of the BEMF feature in chapter 7 • Update the typ. values of all charge/discharge currents in registers • Update the HS/LS delay on/off time • Update the gate driver current turn-on/turn-off rise time • Update the rise time of CP1 • Update the rise time of CP2 • Update the turn-on time of CP2

Revision number	Date of release	Description of changes
Rev. 0.02	2021-04-15	<ul style="list-style-type: none"> • Update the values and the conditions of off-state open load diagnosis: I_{PUDIag}, I_{PDDiag}, I_{PDDiag}/I_{PUDIag} • Update the typ. and max. values of I_{SM_NOR1} • Update the max. values of t_{VASDO} and t_{ENSDO} • Update the min. value of V_{GSHM} • Update the description and figures of "Resume normal operation from VSM overvoltage event": "t_{GD_filt}" is replaced with "t_{BLK_VCPX} and t_{GD_filt}" • Update the description of gate driver control in chapter 6.1 • Add an additional description "low-side MOSFET latched on" in chapter 5.8.2 • Update the condition of V_{IL2_IN} • Remove the conditions of R_{PD_SDI}, R_{PD_SCLK}, R_{PD_ILx} and R_{PD_IHx}. • Change max. operation voltage to 72V • Correct a typo in table 43 • Correct a typo in chapter 8.3 • Add an additional description in chapter 6.1 • Update the figures of gate driver control in chapter 6.1 • Correct typos in chapter 6 • Update the conditions of I_{SM_NOR1} and I_{SM_NOR2} • Replace the PRQ numbers with P numbers • Remove the footnote "Not subject to production test, specified by design." • Modify global status register 4 • Add general control register 14 for BEMF processing • Update the BEMF description in chapter 7 • Smaller capitalization and standardization updates through the document
Rev. 0.01.3	2020-11-06	<ul style="list-style-type: none"> • Update min. value of GHM, GLM and SHM • Update voltage range at CP1 • Update ASIL level of EN Low filter time • Update high input voltage threshold, low input voltage threshold and hysteresis of ILx and IHx • Update general control register 1, 4, 5, 6, 7, 8, 9, 10 and 11 • Footnotes are updated • Add a simplified application figure for in product description folder • Add a title to the figure "In - frame response" • Add a marking for the package • Delete the redundant "Status" in "Configurable turn-on of the low-side MOSFET"

12 Revision history

Revision number	Date of release	Description of changes
Rev. 0.01.2	2020-05-18	<ul style="list-style-type: none">• Update application figures• Add additional description for LSAFW, delay time, rising/failing time, exit stop mode, deglitch feature and cross current protection• Correct typos• Update following specs: FHTI, sleep mode delay, EN low filter time and pull-up/down diagnosis current.
Rev. 0.01.1	2020-03-11	first release

Trademarks

All referenced product or service names and trademarks are the property of their respective owners.

Edition 2022-10-04

Published by

Infineon Technologies AG

81726 Munich, Germany

© 2022 Infineon Technologies AG

All Rights Reserved.

Do you have a question about any aspect of this document?

Email: erratum@infineon.com

Document reference

IFX-iid1665489703865

Important notice

The information given in this document shall in no event be regarded as a guarantee of conditions or characteristics ("Beschaffheitsgarantie").

With respect to any examples, hints or any typical values stated herein and/or any information regarding the application of the product, Infineon Technologies hereby disclaims any and all warranties and liabilities of any kind, including without limitation warranties of non-infringement of intellectual property rights of any third party.

In addition, any information given in this document is subject to customer's compliance with its obligations stated in this document and any applicable legal requirements, norms and standards concerning customer's products and any use of the product of Infineon Technologies in customer's applications.

The data contained in this document is exclusively intended for technically trained staff. It is the responsibility of customer's technical departments to evaluate the suitability of the product for the intended application and the completeness of the product information given in this document with respect to such application.

Warnings

Due to technical requirements products may contain dangerous substances. For information on the types in question please contact your nearest Infineon Technologies office.

Except as otherwise explicitly approved by Infineon Technologies in a written document signed by authorized representatives of Infineon Technologies, Infineon Technologies' products may not be used in any applications where a failure of the product or any consequences of the use thereof can reasonably be expected to result in personal injury.