

THESE DRAWINGS ARE THE PROPERTY OF QUALTEK ELECTRONICS AND NOT TO BE REPRODUCED FOR OR COMMUNICATED TO A THIRD PARTY WITHOUT THE EXPRESS WRITTEN PERMISSION OF AN OFFICER OF QUALTEK ELECTRONICS.

REVISION			
REV.	DESCRIPTION	DATE	APPROVED
B	Updated Notes and Graphics	05-15-13	LY

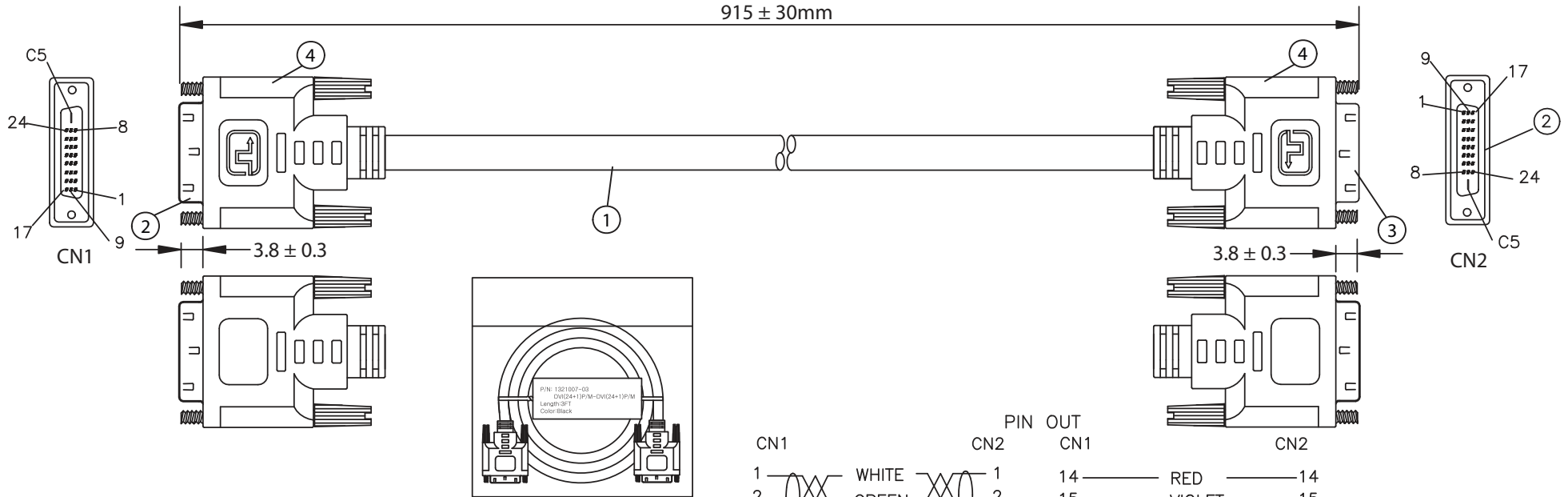

NOTES:

- CABLE: UL20276
(28AWG*1PR+EAM)*7+28AWG*1PR+28AWG*3C+AEB(AL) 65%
OUTER JACKET: BLACK, OD: 8.5 ± 0.2mm
- CONNECTOR: DVI 24+1 MALE
INSULATOR: BLACK
PIN G/F
NICKEL PLATED SHELL
THUMB SCREW: 2.8*32.5 4-40UNC
- CONNECTOR: DVI 24+1 MALE
INSULATOR: BLACK
PIN G/F
NICKEL PLATED SHELL
THUMB SCREW: 2.8*32.5 4-40UNC
- PVC MOLDED: COLOR V398 30P BLACK
- ELECTRICAL TEST:
<1>.100% OPEN SHORT & MISS WIRE TEST
<2>.INSULATION RESISTANCE: AC300V DC400V 10M ohm MIN.
<3>.CONDUCTOR RESISTANCE: 3 ohm MAX.
- PACKING: 1PC/POLYBAG

CN1		CN2		CN1		CN2	
1	WHITE	1	RED	14	RED	14	RED
2	GREEN	2	VIOLET	15	VIOLET	15	VIOLET
3	DRAIN	3	WHITE	16	WHITE	16	WHITE
4	DRAIN	4	PINK	17	PINK	17	PINK
5	BLUE	5	ORANGE	18	ORANGE	18	ORANGE
6	YELLOW	6	DRAIN	19	DRAIN	19	DRAIN
7	ORANGE	7	DRAIN	20	DRAIN	20	DRAIN
8	WHITE	8	BLACK	21	BLACK	21	BLACK
9	WHITE	9	GRAY	22	GRAY	22	GRAY
10	RED	10	LIGHT-BLUE	23	LIGHT-BLUE	23	LIGHT-BLUE
11	DRAIN	11	VIOLET	24	VIOLET	24	VIOLET
12	DRAIN	12	DRAIN		DRAIN		DRAIN
13	WHITE						
	BROWN						
		SHELL	BRAID & DRAIN			SHELL	BRAID & DRAIN

CONTROLLED

Dim range (mm)	Tolerance +/- (mm)	Qualtek Electronics Corp. WCI DIVISION		
		Part Number: 1321007-03	RoHS Compliant	
0-1	0.15	Description: DVI (24+1)P/M - DVI (24+1)P/M		
1-6	0.20		UNIT: mm	REV.B
6-18	0.30	Drawn / Date	Checked / Date	Approved / Date
18-50	0.50	B.Grubb 12-20-06	12-20-06	JJH / 12-20-06
50-120	0.70			
120-250	0.90			
250-500	1.20			