

## Switched Capacitor Voltage Converters with Shutdown in SOT Packages

### Features

- Charge Pumps in 6-Pin SOT-23A Package
- >95% Voltage Conversion Efficiency
- Voltage Inversion and/or Doubling
- Operates from +2.5V to +5.5V
- Up to 25mA Output Current
- Only Two External Capacitors Required
- Low Power Consumption
- Power-Saving Shutdown Mode
- TC1220 Compatible with 1.8V Logic Systems

### Applications

- LCD Panel Bias
- Cellular Phones
- Pagers
- PDAs, Portable Dataloggers
- Battery-Powered Devices

### Device Selection Table

Part Number	Package	Osc. Freq. (kHz)	Operating Temp. Range
TC1219ECH	6-Pin SOT-23A	12	-40°C to +85°C
TC1220ECH	6-Pin SOT-23A	35	-40°C to +85°C

### Package Type

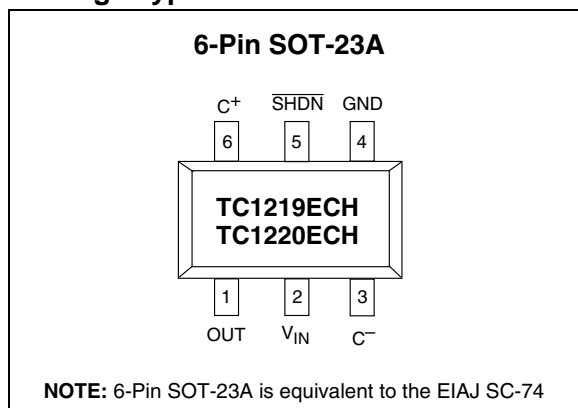

### General Description

The TC1219/TC1220 are CMOS “charge-pump” voltage converters in ultra-small 6-Pin SOT-23A packages. They invert and/or double an input voltage which can range from +2.5V to +5.5V. Conversion efficiency is typically >95%. Switching frequency is 12kHz for the TC1219, 35kHz for the TC1220. When the shutdown pin is held at a logic low, the device goes into a very low power mode of operation, consuming less than 1 $\mu$ A of supply current.

External component requirement is only two capacitors for standard voltage inverter applications. With a few additional components a positive doubler can also be built. All other circuitry, including control, oscillator, power MOSFETs are integrated on-chip. Typical supply currents are 60 $\mu$ A (TC1219), 115 $\mu$ A (TC1220).

All devices are available in 6-pin SOT-23A surface mount packages.

### Functional Block Diagram

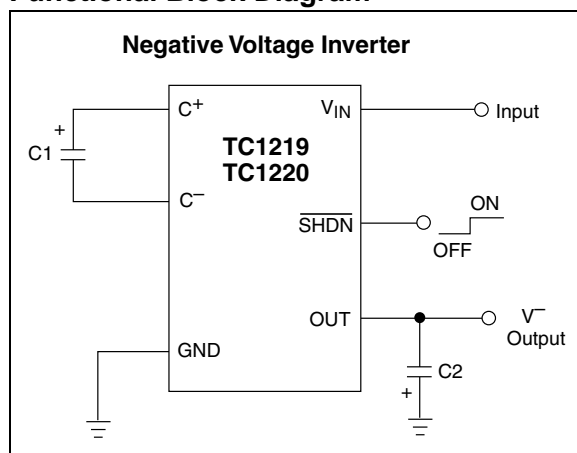

# TC1219/TC1220

## 1.0 ELECTRICAL CHARACTERISTICS

### Absolute Maximum Ratings\*

Input Voltage ( $V_{IN}$ to GND).....	+6.0V, -0.3V
Output Voltage (OUT to GND).....	-6.0V, +0.3V
Current at OUT Pin.....	50mA
Short-Circuit Duration – OUT to GND .....	Indefinite
Power Dissipation ( $T_A \leq 70^\circ\text{C}$ )	
6-Pin SOT-23A .....	240mW
Operating Temperature Range.....	-40°C to +85°C
Storage Temperature (Unbiased) .....	-65°C to +150°C

Stresses above those listed under "Absolute Maximum Ratings" may cause permanent damage to the device. These are stress ratings only and functional operation of the device at these or any other conditions above those indicated in the operation sections of the specifications is not implied. Exposure to Absolute Maximum Rating conditions for extended periods may affect device reliability.

### TC1219/TC1220 ELECTRICAL SPECIFICATIONS

Electrical Characteristics: $T_A = -40^\circ\text{C}$ to $+85^\circ\text{C}$ , $V_{IN} = +5\text{V}$ , $C1 = C2 = 10\mu\text{F}$ , (TC1219), $C1 = C2 = 3.3\mu\text{F}$ (TC1220), $T_A = 25^\circ\text{C}$ unless otherwise noted.							
Symbol	Parameter	Min	Typ	Max	Units	Device	Test Conditions
$I_{DD}$	Supply Current	—	60	115	$\mu\text{A}$	TC1219 TC1220	
$I_{SHDN}$	Shutdown Supply Current	—	0.1	1.0	$\mu\text{A}$		$\overline{\text{SHDN}} = \text{GND}$ , $V_{IN} = 5\text{V}$ (Note 2)
$V_{MIN}$	Minimum Supply Voltage	2.5	—	—	V		$R_{LOAD} = 1\text{k}\Omega$
$V_{MAX}$	Maximum Supply Voltage	—	—	5.5	V		$R_{LOAD} = 1\text{k}\Omega$
$F_{OSC}$	Oscillator Frequency	6	12	20	kHz	TC1219 TC1220	
$V_{IH}$	SHDN Input Logic High	—	—	—	V	TC1219 TC1220	$R_{LOAD} = \infty$ $V_{IN} = V_{MIN}$ to 3V $V_{IN} = >3\text{V}$ to $V_{MAX}$ $V_{IN} = V_{MIN}$ to $V_{MAX}$
$V_{IL}$	SHDN Input Logic Low	—	—	0.5	V		$V_{IN} = V_{MIN}$ to $V_{MAX}$
$P_{EFF}$	Power Efficiency	—	96	—	%		$R_{LOAD} = 1\text{k}\Omega$
$V_{EFF}$	Voltage Conversion Efficiency	95	99.9	—	%		$R_{LOAD} = \infty$
$R_{OUT}$	Output Resistance	—	25	65	$\Omega$	TC1219/TC1220	$I_{LOAD} = 0.5\text{mA}$ to 25mA (Note 1)

- Note** 1: Capacitor contribution is approximately 20% of the output impedance [ESR = 1/ pump frequency x capacitance].  
 2:  $V_{IN}$  is guaranteed to be disconnected from OUT when the converter is in shutdown..

## 2.0 PIN DESCRIPTIONS

The descriptions of the pins are listed in Table 2-1.

**TABLE 2-1: PIN FUNCTION TABLE**

Pin No. (6-Pin SOT-23A)	Symbol	Description
1	OUT	Inverting charge pump output.
2	V <sub>IN</sub>	Positive power supply input.
3	C <sup>-</sup>	Commutation capacitor negative terminal.
4	GND	Ground.
5	$\overline{\text{SHDN}}$	Shutdown input (active low).
6	C <sup>+</sup>	Commutation capacitor positive terminal.

# TC1219/TC1220

## 3.0 DETAILED DESCRIPTION

The TC1219/TC1220 charge pump converters invert the voltage applied to the  $V_{IN}$  pin. Conversion consists of a two-phase operation (Figure 3-1). During the first phase, switches S2 and S4 are opened and S1 and S3 are closed. During this time, C1 charges to the voltage on  $V_{IN}$  and load current is supplied from C2. During the second phase, S2 and S4 are closed, and S1 and S3 are opened. This action connects C1 across C2, restoring charge to C2.

**FIGURE 3-1: IDEAL SWITCHED CAPACITOR CHARGE PUMP**

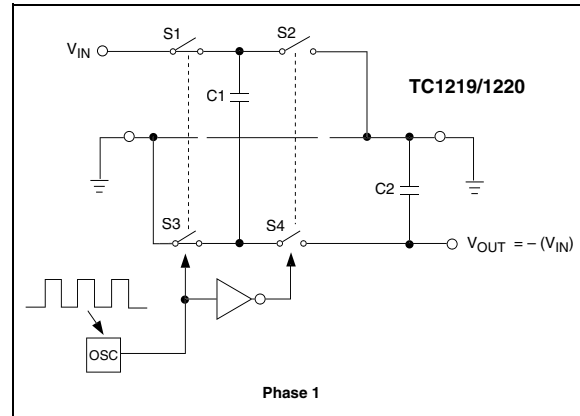

## 4.0 APPLICATIONS INFORMATION

### 4.1 Output Voltage Considerations

The TC1219/TC1220 perform voltage conversion but do not provide *regulation*. The output voltage will droop in a linear manner with respect to load current. The value of this equivalent output resistance is approximately 25Ω nominal at +25°C and  $V_{IN} = +5V$ .  $V_{OUT}$  is approximately -5V at light loads, and droops according to the equation below:

$$V_{DROP} = I_{OUT} \times R_{OUT}$$

$$V_{OUT} = - (V_{IN} - V_{DROP})$$

### 4.2 Charge Pump Efficiency

The overall power efficiency of the charge pump is affected by four factors:

1. Losses from power consumed by the internal oscillator, switch drive, etc. (which vary with input voltage, temperature and oscillator frequency).
2.  $I^2R$  losses due to the on-resistance of the MOSFET switches on-board the charge pump.
3. Charge pump capacitor losses due to effective series resistance (ESR).
4. Losses that occur during charge transfer (from the commutation capacitor to the output capacitor) when a voltage difference between the two capacitors exists.

Most of the conversion losses are due to factors (2) and (3) above. These losses are given by Equation 4-1(b).

#### EQUATION 4-1:

$$a) P_{LOSS(2,3)} = I_{OUT}^2 \times R_{OUT}$$

$$b) \text{ where } R_{OUT} = \left[ \frac{1}{f_{OSC}(C1)} \right] + 8R_{SWITCH} + 4ESRC1 + ESR_{C2}$$

The  $1/(f_{OSC})(C1)$  term in Equation 4-1(b) is the effective output resistance of an ideal switched capacitor circuit (Figure 4-1 and Figure 4-2). The value of  $R_{SWITCH}$  can be approximated at 0.5Ω for the TC1219/TC1220.

The remaining losses in the circuit are due to factor (4) above, and are shown in Equation 4-2. The output voltage ripple is given by Equation 4-3.

#### EQUATION 4-2:

$$P_{LOSS(4)} = \left[ (0.5)(C1)(V_{IN}^2 - V_{OUT}^2) + (0.5)(C2)(V_{RIPPLE}^2 - 2V_{OUT} V_{RIPPLE}) \right] \times f_{OSC}$$

#### EQUATION 4-3:

$$V_{RIPPLE} = \left[ I_{OUT} / 2 \times (f_{OSC})(C2) \right] + 2(I_{OUT})(ESR_{C2})$$

**FIGURE 4-1: IDEAL SWITCHED CAPACITOR MODEL**

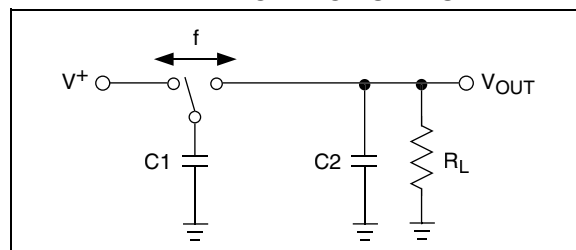

**FIGURE 4-2: EQUIVALENT OUTPUT RESISTANCE**

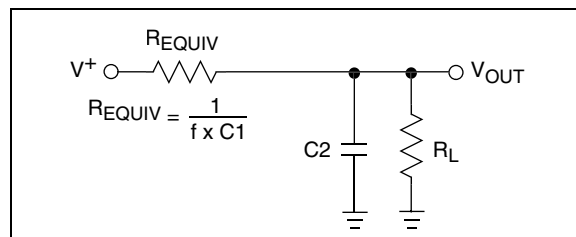

# TC1219/TC1220

## 4.3 Capacitor Selection

In order to maintain the lowest output resistance and output ripple voltage, it is recommended that low ESR capacitors be used. Additionally, larger values of C1 will lower the output resistance and larger values of C2 will reduce output ripple. (Equation 4-1(b) and Equation 4-3).

Table 4-1 shows various values of C1 and the corresponding output resistance values @ +25°C. It assumes a 0.1Ω ESR<sub>C1</sub> and 2Ω R<sub>SWITCH</sub>. Table 4-2 shows the output voltage ripple for various values of C2. The V<sub>RIPPLE</sub> values assume 10mA output load current and 0.1Ω ESR<sub>C2</sub>.

**TABLE 4-1: OUTPUT RESISTANCE VS. C1 (ESR = 0.1Ω)**

C1 (μF)	TC1219 R <sub>OUT</sub> (Ω)	TC1220 R <sub>OUT</sub> (Ω)
1	100	45
3.3	42	25
10	25	19.4
30	19.3	17.5

**TABLE 4-2: OUTPUT VOLTAGE RIPPLE VS. C2 (ESR = 0.1Ω)  
I<sub>OUT</sub> 10mA**

C2 (μF)	TC1219 V <sub>RIPPLE</sub> (mV)	TC1220 V <sub>RIPPLE</sub> (mV)
1	419	145
3.3	128	45
10	44	16
30	16	7

## 4.4 Input Supply Bypassing

The V<sub>IN</sub> input should be capacitively bypassed to reduce AC impedance and minimize noise effects due to the internal switching of the device. The recommended capacitor depends on the configuration of the TC1219/TC1220.

## 4.5 Shutdown Input

The TC1219/TC1220 is enabled when  $\overline{\text{SHDN}}$  is high, and disabled when  $\overline{\text{SHDN}}$  is low. This input cannot be allowed to float. (If  $\overline{\text{SHDN}}$  is not required, see the TCM828/829 data sheet.) The  $\overline{\text{SHDN}}$  input can be only driven to 0.5V above V<sub>IN</sub> to avoid significant current flows.

## 4.6 Voltage Inverter

The most common application for charge pump devices is the inverter (Figure 4-3). This application uses two external capacitors: C1 and C2 (plus a power supply bypass capacitor, if necessary). The output is equal to -V<sub>IN</sub> plus any voltage drops due to loading. Refer to Table 4-1 and Table 4-2 for capacitor selection.

**FIGURE 4-3: VOLTAGE INVERTER TEST CIRCUIT**

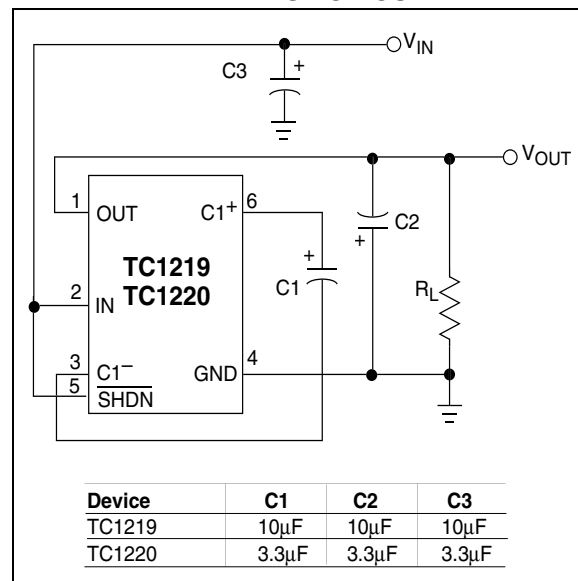

## 4.7 Cascading Devices

Two or more TC1219/TC1220 can be cascaded to increase output voltage (Figure 4-4). If the output is lightly loaded, it will be close to  $(-2 \times V_{IN})$  but will droop at least by  $R_{OUT}$  of the first device multiplied by the  $I_Q$  of the second. It can be seen that the output resistance rises rapidly for multiple cascaded devices.

## 4.8 Paralleling Devices

To reduce the value of  $R_{OUT}$ , multiple TC1219/TC1220's can be connected in parallel (Figure 4-5). The output resistance will be reduced by a factor of N where N is the number of TC1219/TC1220. Each device will require its own pump capacitor (C1), but all devices may share one reservoir capacitor (C2). However, to preserve ripple performance the value of C2 should be scaled according to the number of paralleled TC1219/TC1220.

**FIGURE 4-4: CASCADING MULTIPLE DEVICES TO INCREASE OUTPUT VOLTAGE**

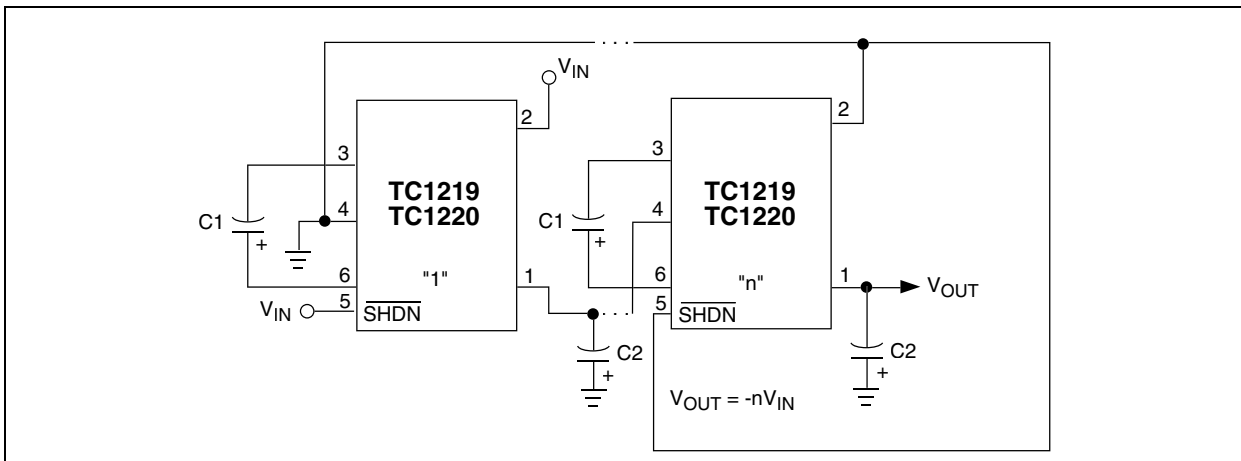

**FIGURE 4-5: PARALLELING MULTIPLE DEVICES TO REDUCE OUTPUT RESISTANCE**

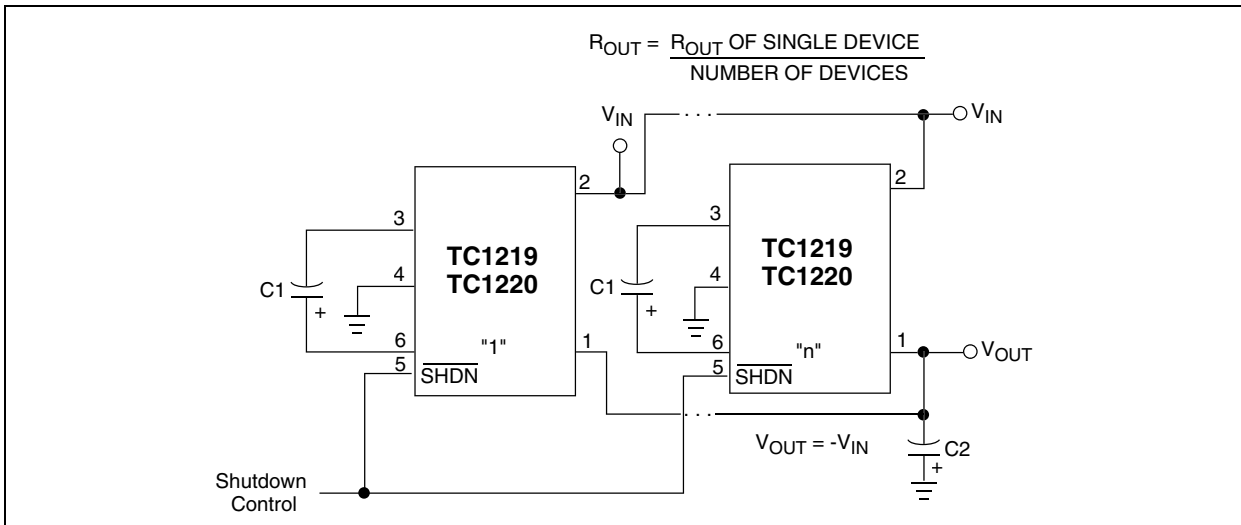

# TC1219/TC1220

## 4.9 Voltage Doubler/Inverter

Another common application of the TC1219/TC1220 is shown in Figure 4-6. This circuit performs two functions in combination. C1 and C2 form the standard inverter circuit described previously. C3 and C4 plus the two diodes form the voltage doubler circuit. C1 and C3 are the pump capacitors and C2 and C4 are the reservoir capacitors. Because both sub-circuits rely on the same switches if either output is loaded, both will droop toward GND. Make sure that the total current drawn from both the outputs does not total more than 40mA.

## 4.10 Diode Protection for Heavy Loads

When heavy loads require the OUT pin to sink large currents being delivered by a positive source, diode protection may be needed. The OUT pin should not be allowed to be pulled above ground. This is accomplished by connecting a Schottky diode (1N5817) as shown in Figure 4-7.

## 4.11 Layout Considerations

As with any switching power supply circuit good layout practice is recommended. Mount components as close together as possible to minimize stray inductance and capacitance. Noise leakage into other circuitry can be minimized with the use of a large ground plane.

FIGURE 4-6: COMBINED DOUBLER AND INVERTER

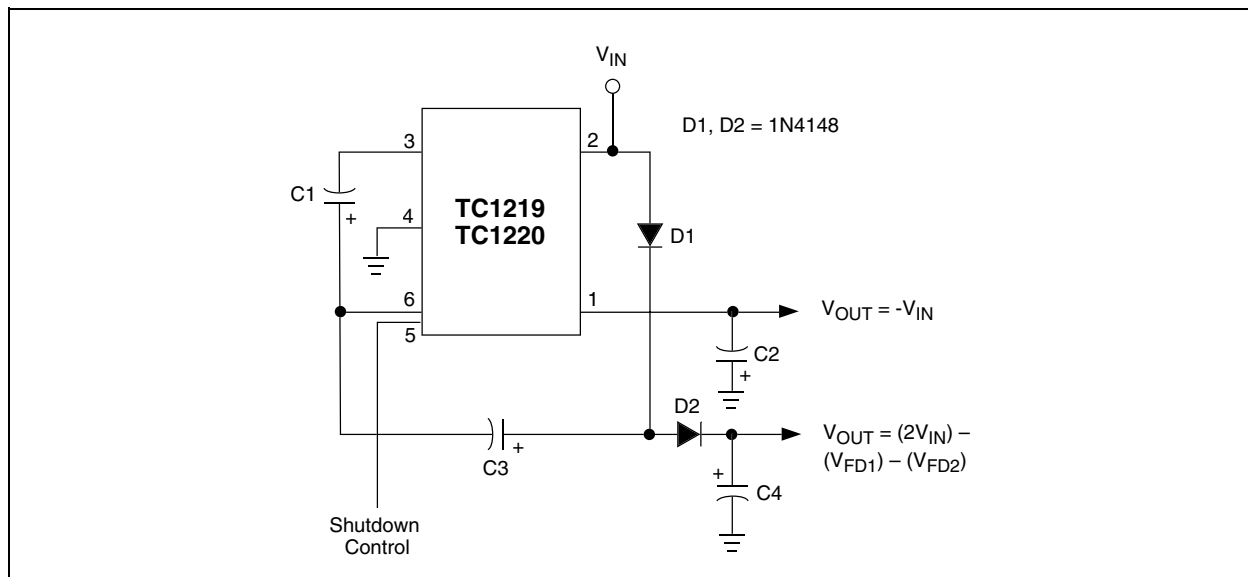
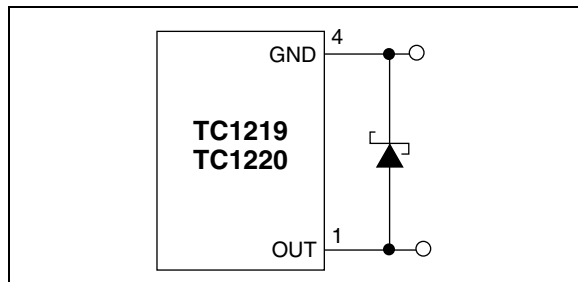

FIGURE 4-7: HIGH V- LOAD CURRENT





## 5.0 TYPICAL CHARACTERISTICS

**Note:** The graphs and tables provided following this note are a statistical summary based on a limited number of samples and are provided for informational purposes only. The performance characteristics listed herein are not tested or guaranteed. In some graphs or tables, the data presented may be outside the specified operating range (e.g., outside specified power supply range) and therefore outside the warranted range.

Circuit of Figure 4-3,  $V_{IN} = +5V$ ,  $C1 = C2 = C3$ ,  $T_A = 25^\circ C$  unless otherwise noted.

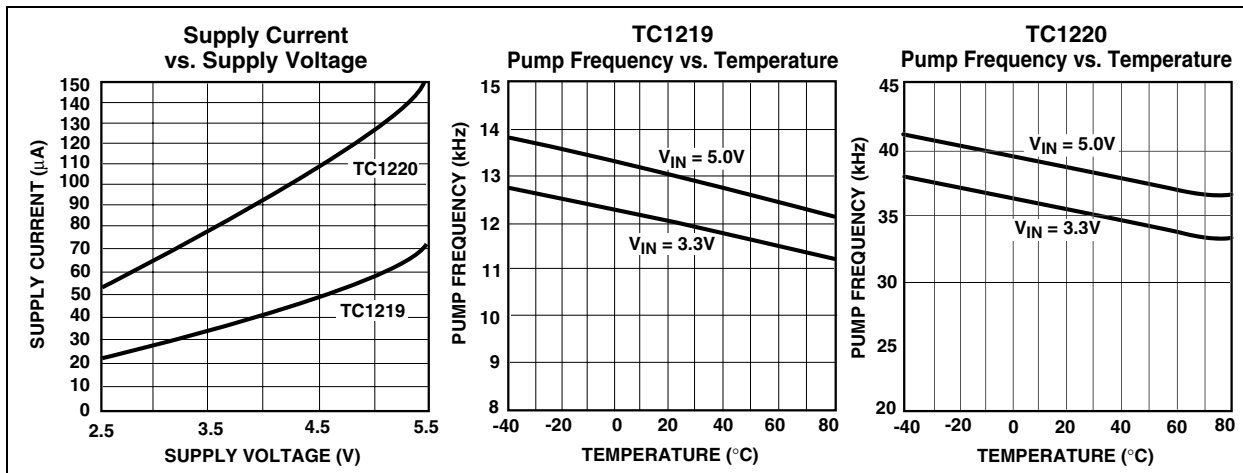
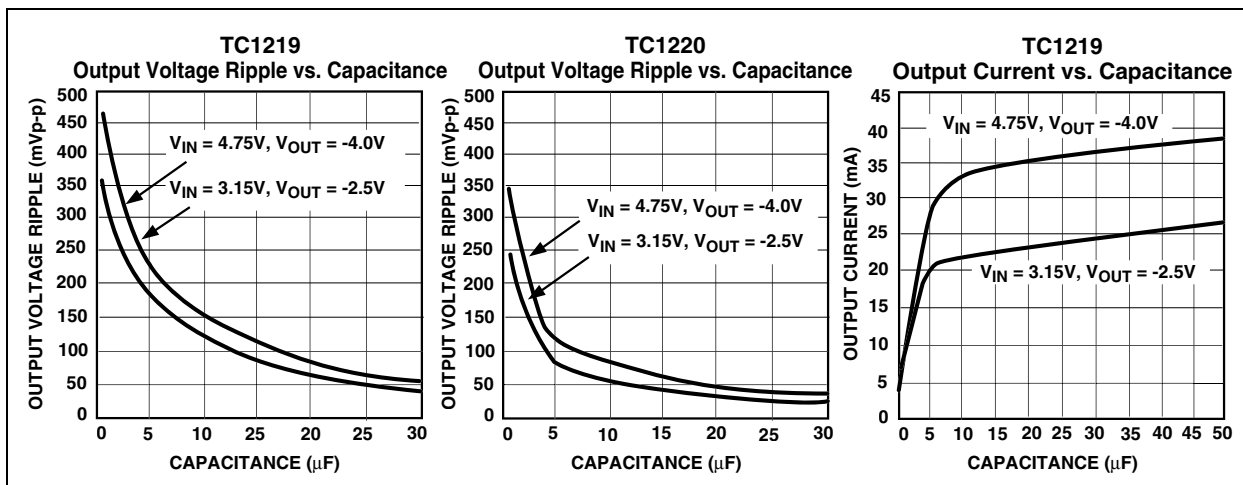
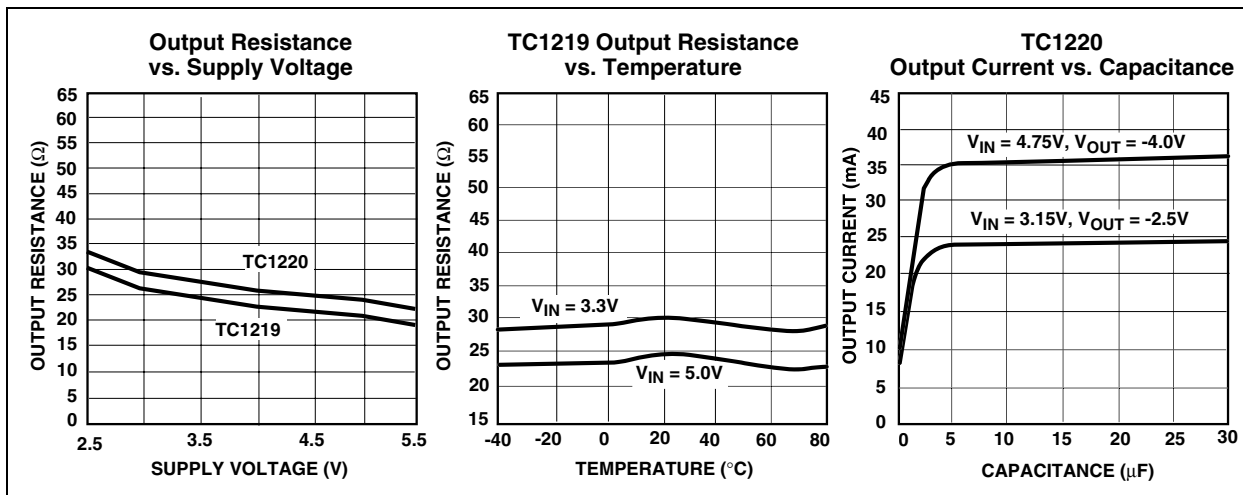

# TC1219/TC1220

## TYPICAL CHARACTERISTICS (CONTINUED)

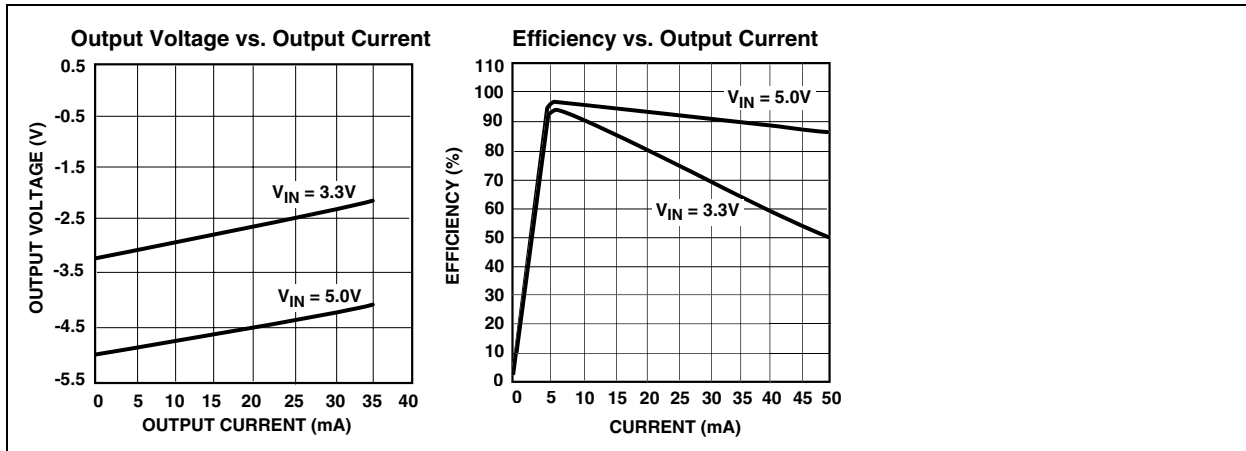

## 6.0 PACKAGING INFORMATION

### 6.1 Package Marking Information

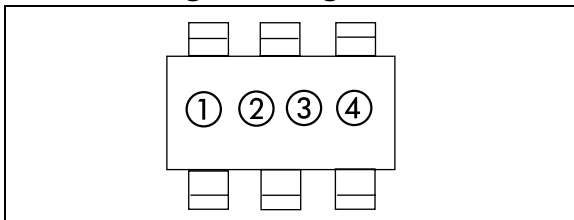

① & ② = part number code + temperature range  
(two-digit code)

TC1219/TC1220	Code
TC1219ECH	AM
TC1220ECH	AN

ex: 1219ECH = (A) (M) ○ ○

③ represents year and quarter code

④ represents production lot ID code

### 6.2 Taping Form

#### Component Taping Orientation for 6-Pin SOT-23A (EIAJ SC-74) Devices

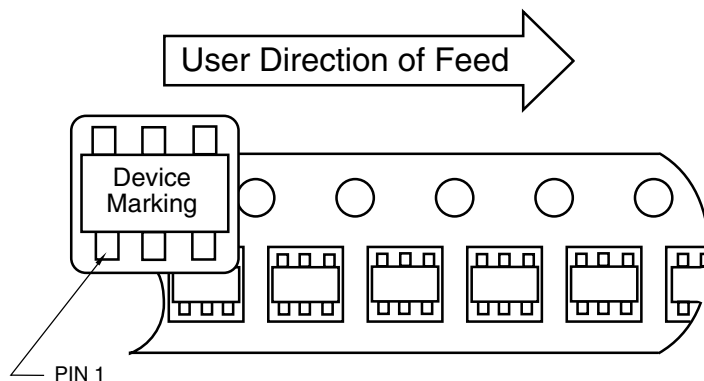

Standard Reel Component Orientation  
For TR Suffix Device  
(Mark Right Side Up)

#### Carrier Tape, Number of Components Per Reel and Reel Size

Package	Carrier Width (W)	Pitch (P)	Part Per Full Reel	Reel Size
6-Pin SOT-23A	8 mm	4 mm	3000	7 in

# TC1219/TC1220

## 6.3 Package Dimensions

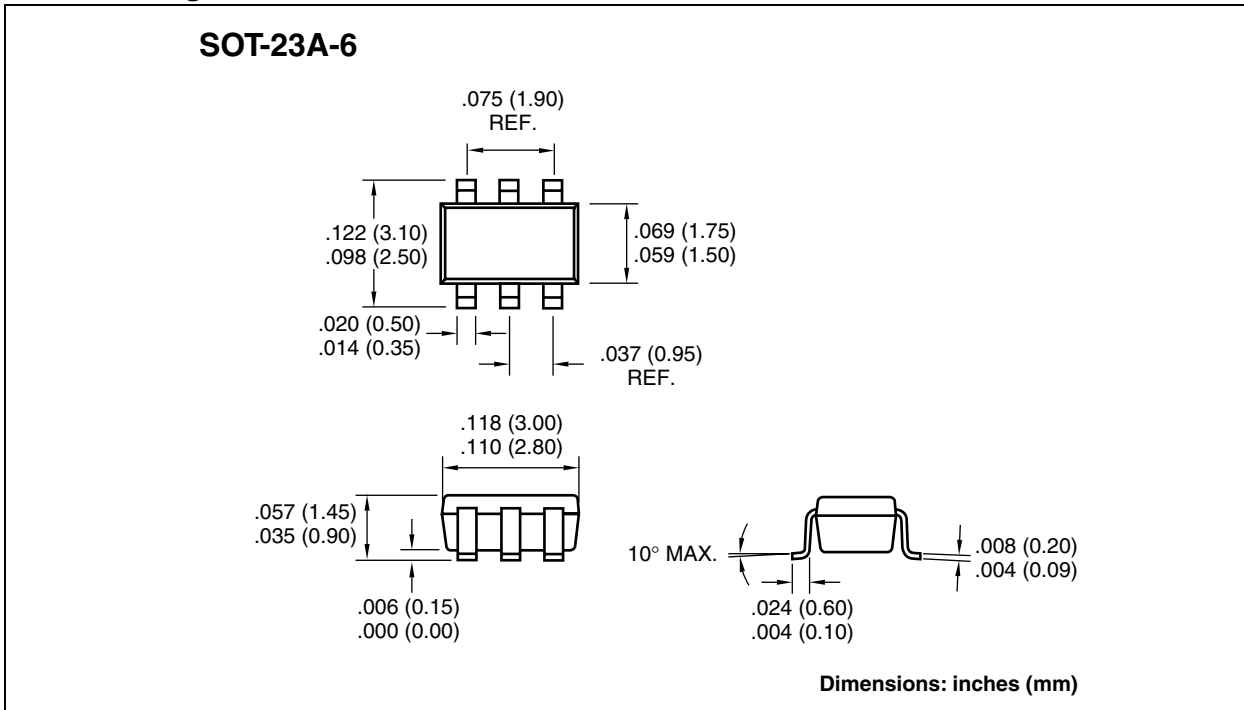

## **Sales and Support**

### **Data Sheets**

Products supported by a preliminary Data Sheet may have an errata sheet describing minor operational differences and recommended workarounds. To determine if an errata sheet exists for a particular device, please contact one of the following:

1. Your local Microchip sales office
2. The Microchip Corporate Literature Center U.S. FAX: (480) 792-7277
3. The Microchip Worldwide Site ([www.microchip.com](http://www.microchip.com))

Please specify which device, revision of silicon and Data Sheet (include Literature #) you are using.

### **New Customer Notification System**

Register on our web site ([www.microchip.com/cn](http://www.microchip.com/cn)) to receive the most current information on our products.

# TC1219/TC1220

---

---

NOTES:

Information contained in this publication regarding device applications and the like is intended through suggestion only and may be superseded by updates. It is your responsibility to ensure that your application meets with your specifications. No representation or warranty is given and no liability is assumed by Microchip Technology Incorporated with respect to the accuracy or use of such information, or infringement of patents or other intellectual property rights arising from such use or otherwise. Use of Microchip's products as critical components in life support systems is not authorized except with express written approval by Microchip. No licenses are conveyed, implicitly or otherwise, under any intellectual property rights.

## Trademarks

The Microchip name and logo, the Microchip logo, FilterLab, KEELOQ, microID, MPLAB, PIC, PICmicro, PICMASTER, PICSTART, PRO MATE, SEEVAL and The Embedded Control Solutions Company are registered trademarks of Microchip Technology Incorporated in the U.S.A. and other countries.

dsPIC, ECONOMONITOR, FanSense, FlexROM, fuzzyLAB, In-Circuit Serial Programming, ICSP, ICEPIC, microPort, Migratable Memory, MPASM, MPLIB, MPLINK, MPSIM, MXDEV, PICC, PICDEM, PICDEM.net, rfPIC, Select Mode and Total Endurance are trademarks of Microchip Technology Incorporated in the U.S.A.

Serialized Quick Turn Programming (SQTP) is a service mark of Microchip Technology Incorporated in the U.S.A.

All other trademarks mentioned herein are property of their respective companies.

© 2002, Microchip Technology Incorporated, Printed in the U.S.A., All Rights Reserved.

 Printed on recycled paper.

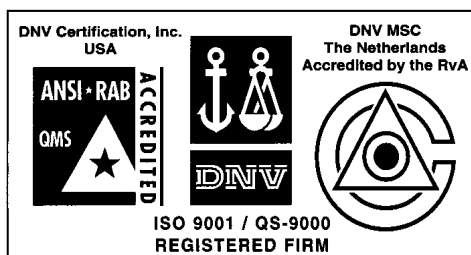

*Microchip received QS-9000 quality system certification for its worldwide headquarters, design and wafer fabrication facilities in Chandler and Tempe, Arizona in July 1999 and Mountain View, California in March 2002. The Company's quality system processes and procedures are QS-9000 compliant for its PICmicro® 8-bit MCUs, KEELOQ® code hopping devices, Serial EEPROMs, microperipherals, non-volatile memory and analog products. In addition, Microchip's quality system for the design and manufacture of development systems is ISO 9001 certified.*



# MICROCHIP

## WORLDWIDE SALES AND SERVICE

### AMERICAS

#### Corporate Office

2355 West Chandler Blvd.  
Chandler, AZ 85224-6199  
Tel: 480-792-7200 Fax: 480-792-7277  
Technical Support: 480-792-7627  
Web Address: <http://www.microchip.com>

#### Rocky Mountain

2355 West Chandler Blvd.  
Chandler, AZ 85224-6199  
Tel: 480-792-7966 Fax: 480-792-7456

#### Atlanta

500 Sugar Mill Road, Suite 200B  
Atlanta, GA 30350  
Tel: 770-640-0034 Fax: 770-640-0307

#### Boston

2 Lan Drive, Suite 120  
Westford, MA 01886  
Tel: 978-692-3848 Fax: 978-692-3821

#### Chicago

333 Pierce Road, Suite 180  
Itasca, IL 60143  
Tel: 630-285-0071 Fax: 630-285-0075

#### Dallas

4570 Westgrove Drive, Suite 160  
Addison, TX 75001  
Tel: 972-818-7423 Fax: 972-818-2924

#### Detroit

Tri-Atria Office Building  
32255 Northwestern Highway, Suite 190  
Farmington Hills, MI 48334  
Tel: 248-538-2250 Fax: 248-538-2260

#### Kokomo

2767 S. Albright Road  
Kokomo, Indiana 46902  
Tel: 765-864-8360 Fax: 765-864-8387

#### Los Angeles

18201 Von Karman, Suite 1090  
Irvine, CA 92612  
Tel: 949-263-1888 Fax: 949-263-1338

#### New York

150 Motor Parkway, Suite 202  
Hauppauge, NY 11788  
Tel: 631-273-5305 Fax: 631-273-5335

#### San Jose

Microchip Technology Inc.  
2107 North First Street, Suite 590  
San Jose, CA 95131  
Tel: 408-436-7950 Fax: 408-436-7955

#### Toronto

6285 Northam Drive, Suite 108  
Mississauga, Ontario L4V 1X5, Canada  
Tel: 905-673-0699 Fax: 905-673-6509

### ASIA/PACIFIC

#### Australia

Microchip Technology Australia Pty Ltd  
Suite 22, 41 Rawson Street  
Epping 2121, NSW  
Australia  
Tel: 61-2-9868-6733 Fax: 61-2-9868-6755

#### China - Beijing

Microchip Technology Consulting (Shanghai)  
Co., Ltd., Beijing Liaison Office  
Unit 915  
Bei Hai Wan Tai Bldg.  
No. 6 Chaoyangmen Beidajie  
Beijing, 100027, No. China  
Tel: 86-10-85282100 Fax: 86-10-85282104

#### China - Chengdu

Microchip Technology Consulting (Shanghai)  
Co., Ltd., Chengdu Liaison Office  
Rm. 2401, 24th Floor,  
Ming Xing Financial Tower  
No. 88 TIDU Street  
Chengdu 610016, China  
Tel: 86-28-6766200 Fax: 86-28-6766599

#### China - Fuzhou

Microchip Technology Consulting (Shanghai)  
Co., Ltd., Fuzhou Liaison Office  
Unit 28F, World Trade Plaza  
No. 71 Wusi Road  
Fuzhou 350001, China  
Tel: 86-591-7503506 Fax: 86-591-7503521

#### China - Shanghai

Microchip Technology Consulting (Shanghai)  
Co., Ltd.  
Room 701, Bldg. B  
Far East International Plaza  
No. 317 Xian Xia Road  
Shanghai, 200051  
Tel: 86-21-6275-5700 Fax: 86-21-6275-5060

#### China - Shenzhen

Microchip Technology Consulting (Shanghai)  
Co., Ltd., Shenzhen Liaison Office  
Rm. 1315, 13/F, Shenzhen Kerry Centre,  
Renminnan Lu  
Shenzhen 518001, China  
Tel: 86-755-2350361 Fax: 86-755-2366086

#### Hong Kong

Microchip Technology Hongkong Ltd.  
Unit 901-6, Tower 2, Metroplaza  
223 Hing Fong Road  
Kwai Fong, N.T., Hong Kong  
Tel: 852-2401-1200 Fax: 852-2401-3431

#### India

Microchip Technology Inc.  
India Liaison Office  
Divyasree Chambers  
1 Floor, Wing A (A3/A4)  
No. 11, O'Shaugnessey Road  
Bangalore, 560 025, India  
Tel: 91-80-2290061 Fax: 91-80-2290062

### Japan

Microchip Technology Japan K.K.  
Benex S-1 6F  
3-18-20, Shinyokohama  
Kohoku-Ku, Yokohama-shi  
Kanagawa, 222-0033, Japan  
Tel: 81-45-471- 6166 Fax: 81-45-471-6122

### Korea

Microchip Technology Korea  
168-1, Youngbo Bldg. 3 Floor  
Samsung-Dong, Kangnam-Ku  
Seoul, Korea 135-882  
Tel: 82-2-554-7200 Fax: 82-2-558-5934

### Singapore

Microchip Technology Singapore Pte Ltd.  
200 Middle Road  
#07-02 Prime Centre  
Singapore, 188980  
Tel: 65-6334-8870 Fax: 65-6334-8850

### Taiwan

Microchip Technology Taiwan  
11F-3, No. 207  
Tung Hua North Road  
Taipei, 105, Taiwan  
Tel: 886-2-2717-7175 Fax: 886-2-2545-0139

### EUROPE

#### Denmark

Microchip Technology Nordic ApS  
Regus Business Centre  
Lautrup høj 1-3  
Ballerup DK-2750 Denmark  
Tel: 45 4420 9895 Fax: 45 4420 9910

#### France

Microchip Technology SARL  
Parc d'Activite du Moulin de Massy  
43 Rue du Saule Trapu  
Batiment A - 1er Etage  
91300 Massy, France  
Tel: 33-1-69-53-63-20 Fax: 33-1-69-30-90-79

#### Germany

Microchip Technology GmbH  
Gustav-Heinemann Ring 125  
D-81739 Munich, Germany  
Tel: 49-89-627-144 0 Fax: 49-89-627-144-44

#### Italy

Microchip Technology SRL  
Centro Direzionale Colleoni  
Palazzo Taurus 1 V. Le Colleoni 1  
20041 Agrate Brianza  
Milan, Italy  
Tel: 39-039-65791-1 Fax: 39-039-6899883

#### United Kingdom

Arizona Microchip Technology Ltd.  
505 Eskdale Road  
Winnersh Triangle  
Wokingham  
Berkshire, England RG41 5TU  
Tel: 44 118 921 5869 Fax: 44-118 921-5820

03/01/02

