

TO252 PACKAGE OUTLINE

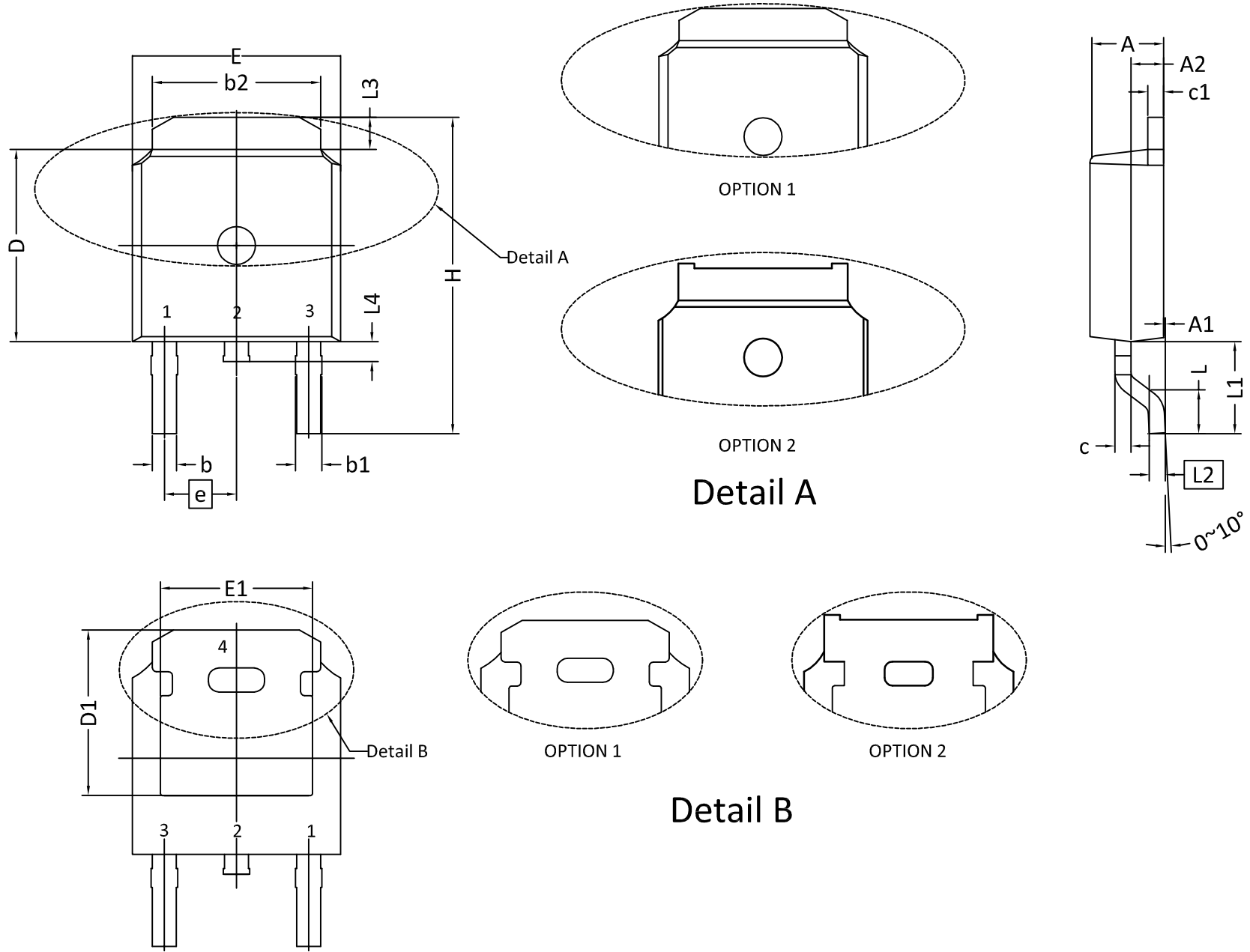

RECOMMENDED LAND PATTERN

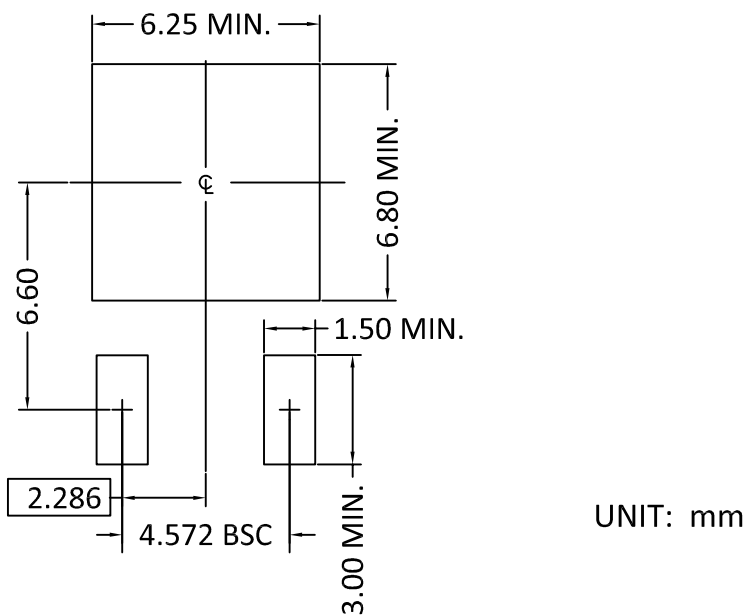

SYMBOLS	DIMENSION IN MM			DIMENSION IN INCHES		
	MIN	NOM	MAX	MIN	NOM	MAX
A	2.184	2.286	2.400	0.086	0.090	0.094
A1	0.000	---	0.200	0.000	---	0.008
A2	0.889	1.041	1.170	0.035	0.041	0.046
b	0.635	0.762	0.889	0.025	0.030	0.035
b1	0.680	0.840	1.143	0.027	0.033	0.045
b2	4.953	5.340	5.500	0.195	0.210	0.217
c	0.450	0.508	0.610	0.018	0.020	0.024
c1	0.450	0.508	0.630	0.018	0.020	0.025
D	5.969	6.096	6.223	0.235	0.240	0.245
D1	5.210	5.249	5.380	0.205	0.207	0.212
E	6.350	6.604	6.800	0.250	0.260	0.268
E1	4.318	4.826	4.920	0.170	0.190	0.194
e	2.286 BSC			0.090 BSC		
e1	4.572 BSC			0.180 BSC		
H	9.398	10.033	10.500	0.370	0.395	0.413
L	1.270	1.520	2.032	0.050	0.060	0.080
L1	2.921 REF.			0.115 REF.		
L2	0.408	0.508	0.608	0.016	0.020	0.024
L3	0.889	1.016	1.270	0.035	0.040	0.050
L4	0.600	---	1.016	0.024	---	0.040

NOTE:

1. PACKAGE BODY SIZES EXCLUDE MOLD FLASH AND GATE BURRS. MOLD FLASH SHOULD BE LESS THAN 6 MILS.
2. DIMENSION L IS MEASURED IN GAUGE PLANE.
3. TOLERANCE 0.10 mm UNLESS OTHERWISE SPECIFIED.
4. CONTROLLING DIMENSION IS MILLIMETER. CONVERTED INCH DIMENSIONS ARE NOT NECESSARILY EXACT.
5. REFER TO JEDEC TO-252 (AA).