

REVISIONS					
P	LTR	DESCRIPTION	DATE	DWN	APVD
C2		REVISED PER ECN-20-100213	16-JUL-20	SK	DZ

- 1 PARTS COMPLY WITH AMP SOLDERABILITY SPECIFICATION 109-11-2.
- 2 WIRE RANGE: 0.3 - 0.9 MM² (22 - 18 AWG).
- 3 INSULATION RANGE: 1.52 - 2.79
- 4 0.00508 MIN BRIGHT TIN-LEAD.
- 5 HOLE DIAMETER TO BE 1.83±0.08 FOR WIRE 0.3 - 0.6 MM² (20 - 22 AWG) OR 1.96±0.08 FOR WIRE 0.8 - 0.9 MM² (18 AWG).
- 6 0.00508 MIN BRIGHT TIN.

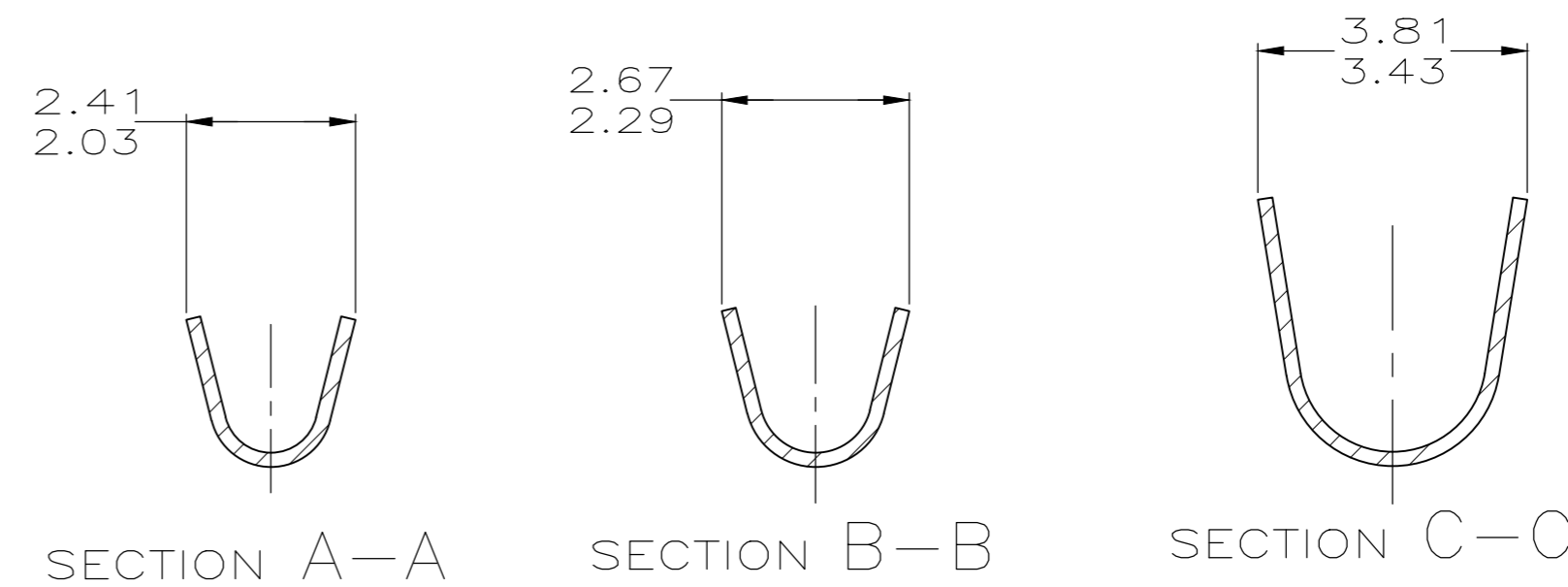
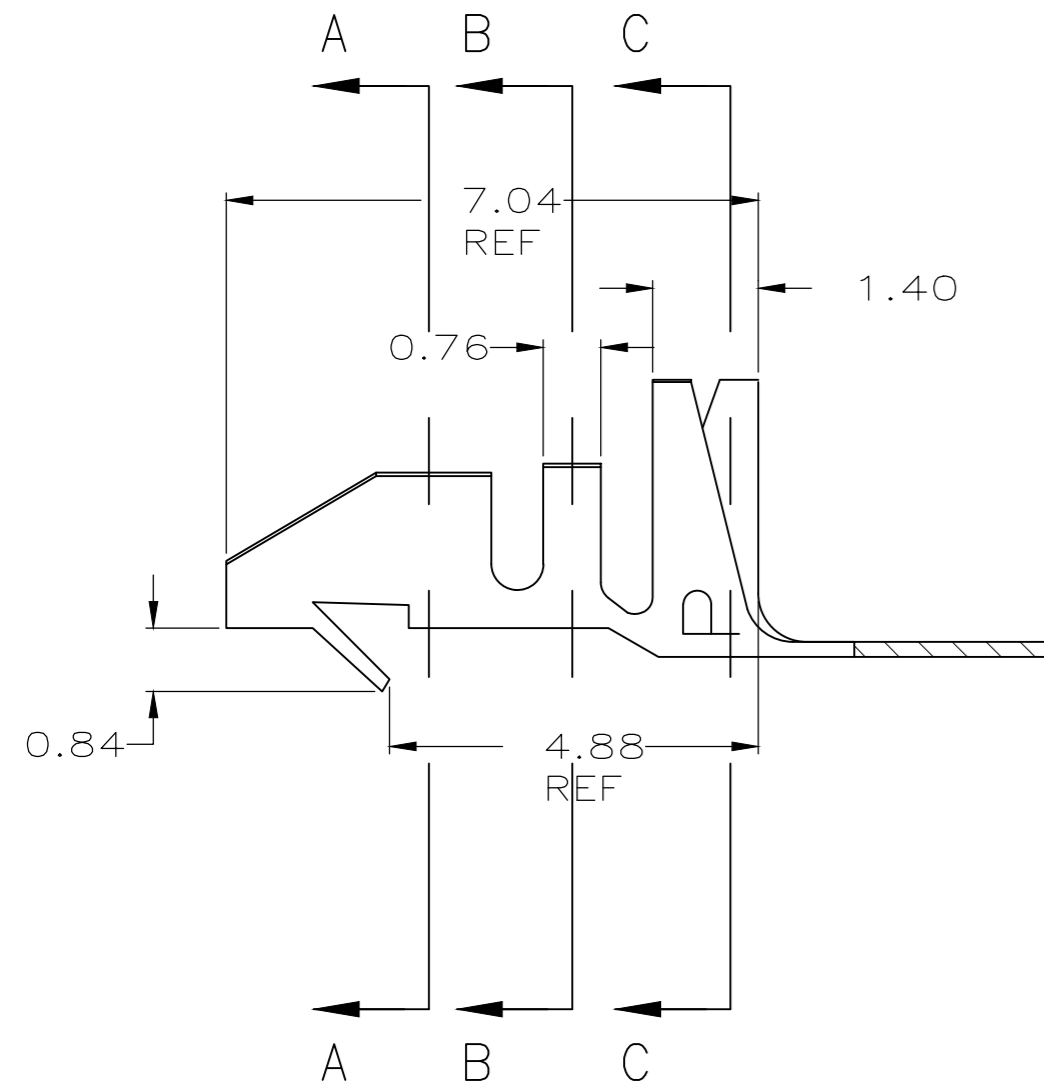
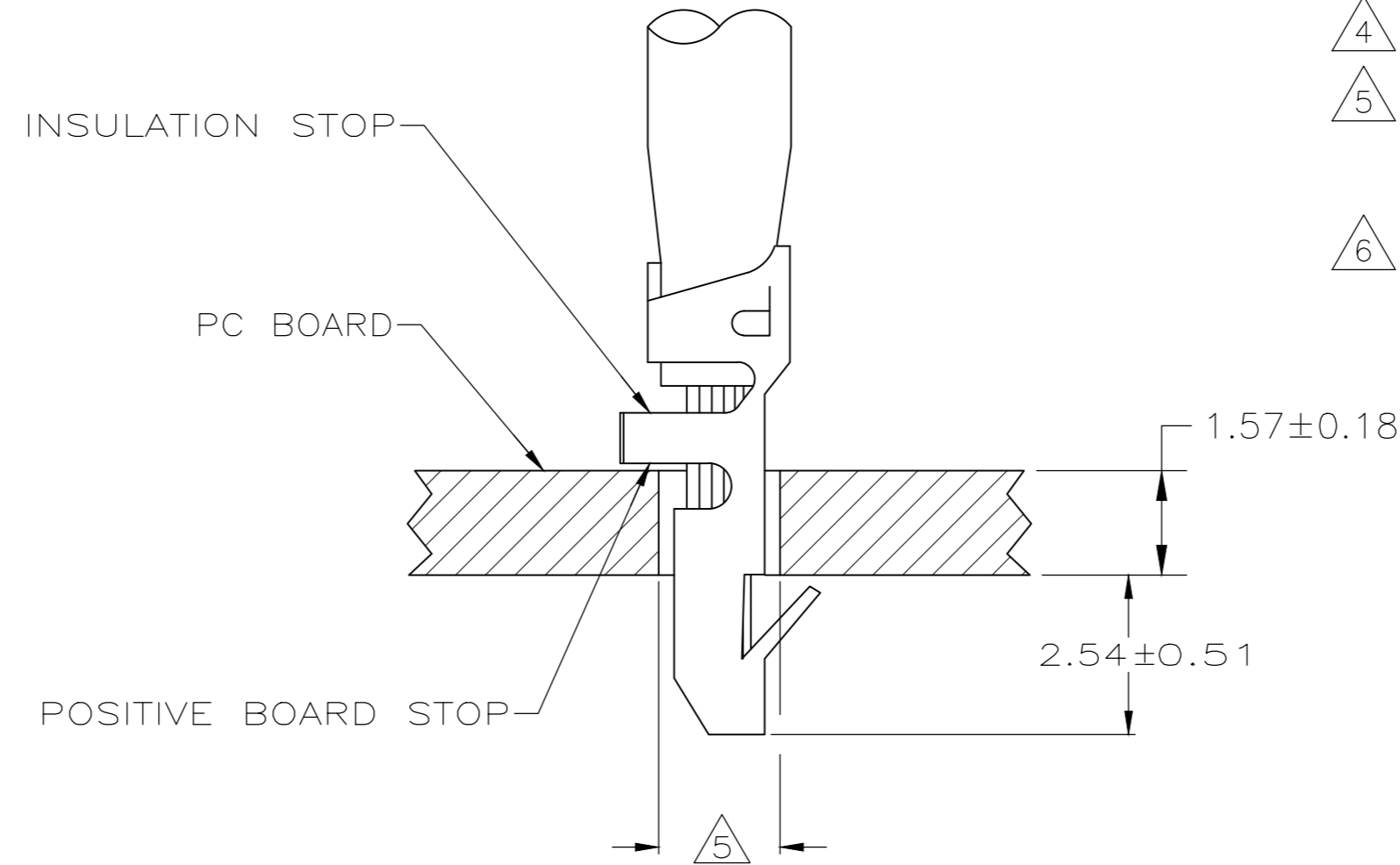
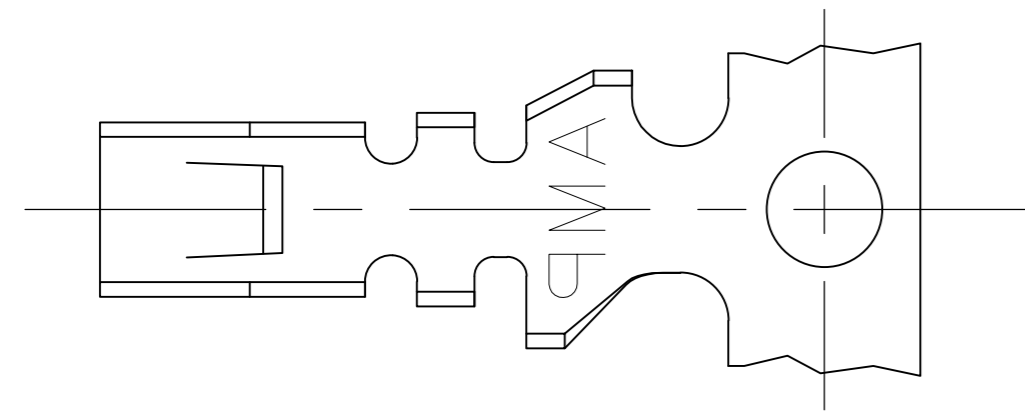

	6	3-794121-1
SUPERSEDED BY	4	-794121-1-
	FINISH	PART NO.

0.51	.020	1.52	.060	2.54	.100	-	-
0.3	.01	1.40	.055	2.41	.095	7.04	.277
0.20	.008	0.9	.04	2.29	.090	4.88	.192
0.18	.007	0.84	.033	2.03	.080	3.81	.150
0.13	.005	0.8	.03	1.96	.077	3.43	.135
0.08	.003	0.76	.030	1.83	.072	2.79	.110
0.00508	.000200	0.6	.02	1.57	.062	2.67	.105
MM	IN	MM	IN	MM	IN	MM	IN

CONVERSION TABLE

METRIC

THIS DRAWING IS A CONTROLLED DOCUMENT.		DWN S. CARPENTER 21AUG2003		
DIMENSIONS: mm		CHK J. ELLIS 21AUG2003		
TOLERANCES UNLESS OTHERWISE SPECIFIED:		APVD J. ELLIS 21AUG2003	NAME TERMINAL, MINI AMP-IN™ 2000	
0 PLC ±		PRODUCT SPEC 108-1081	SIZE A2	
1 PLC ±		APPLICATION SPEC 114-1016	CAGE CODE 00779	DRAWING NO C=794121
2 PLC ± 0.13		WEIGHT -	RESTRICTED TO -	REV C2
3 PLC ±		CUSTOMER DRAWING	SCALE 10:1	SHEET 1 of 1
4 PLC ANGLES ±				
MATERIAL 0.20 PH BRZ		FINISH		