

# TSDS SERIES

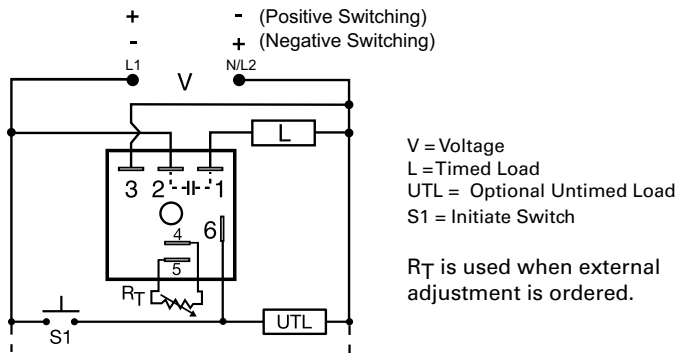

## Wiring Diagram



## Description

The TSDS Series is designed for more demanding commercial and industrial applications where small size and accurate performance are required. The factory calibration for fixed time delays is within 1% of the target time delay. The repeat accuracy, under stable conditions, is 0.5% of the time delay. The TSDS Series is rated to operate over an extended temperature range. Time delays of 0.1 seconds to 1000 minutes are available. The output is rated 1A steady and 10A inrush. The modules are totally solid state and encapsulated to protect the electronic circuitry. This product is suitable for many applications, including dispensing, welding, and exposure timing.

### Operation (Single Shot)

Input voltage must be applied before and during timing. Upon momentary or maintained closure of the initiate switch, the output energizes for a measured interval of time. At the end of the delay, the output de-energizes. Opening or reclosing the initiate switch during timing has no effect on the time delay. The output will not energize if the initiate switch is closed when input voltage is applied.

**Reset:** Reset occurs when the time delay is complete and the initiate switch is opened. Loss of input voltage resets the time delay and output.

## Features & Benefits

FEATURES	BENEFITS
<b>Compact, low cost design measuring 2 in. (50.8mm) square</b>	Allows flexibility for OEM applications
<b>Microcontroller based</b>	Repeat Accuracy +/- 0.5%, Factory calibration +/- 1%
<b>1A Steady, 10A inrush solid-state output</b>	Provides 100 million operations in typical conditions.
<b>Totally solid state and encapsulated</b>	No moving parts to arc and wear out over time and encapsulated to protect against shock, vibration, and humidity
<b>Wide temperature range: -40° to 75°C</b>	Reliable in demanding commercial and industrial applications

## Ordering Information

MODEL	INPUT VOLTAGE	ADJUSTMENT	TIME DELAY	SWITCHING MODE
TSDS2110S	24VAC	Fixed	10s	n/a
TSDS320N	24VDC	External	0.1 - 10s	Negative
TSDS321P	24VDC	External	1 - 100s	Positive
TSDS421	120VAC	External	1 - 100s	n/a

If you don't find the part you need, call us for a custom product 800-843-8848

## Accessories

- P1004-95, P1004-95-X Versa-Pot**  
 Panel mountable, industrial potentiometer recommended for remote time delay adjustment.
- P1023-6 Mounting bracket**  
 The 90° orientation of mounting slots makes installation/removal of modules quick and easy.
- P0700-7 Versa-Knob**  
 Designed for 0.25 in (6.35 mm) shaft of Versa-Pot. Semi-gloss industrial black finish.

## TSDS SERIES

### Accessories



**P1015-64 (AWG 14/16) Female Quick Connect**

These 0.25 in. (6.35 mm) female terminals are constructed with an insulator barrel to provide strain relief.



**P1015-18 Quick Connect to Screw Adapter**

Screw adapter terminal designed for use with all modules with 0.25 in. (6.35 mm) male quick connect terminals.



**C103PM (AL) DIN Rail**

35 mm aluminum DIN rail available in a 36 in. (91.4 cm) length.



**P1023-20 DIN Rail Adapter**

Allows module to be mounted on a 35 mm DIN type rail with two #10 screws.

### External Resistance vs. Time Delay

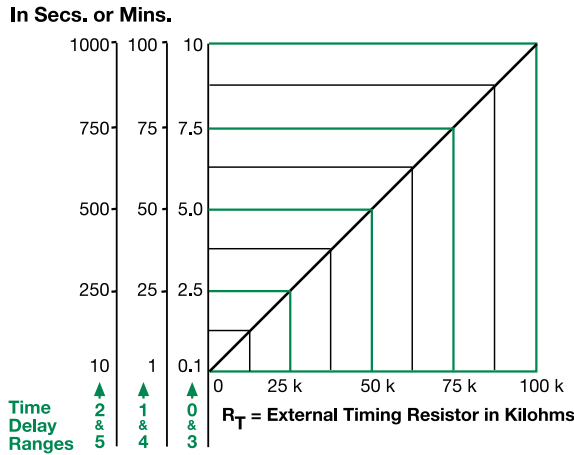

**This chart applies to externally adjustable part numbers.** The time delay is adjustable over the time delay range selected by varying the resistance across the  $R_T$  terminals; as the resistance increases the time delay increases.

When selecting an external  $R_T$ , add the tolerances of the timer and the  $R_T$  for the full time range adjustment.

**Examples:** 1 to 50 S adjustable time delay, select time delay range 1 and a 50 K ohm  $R_T$ . For 1 to 100 S use a 100 K ohm  $R_T$ .

### Function Diagram

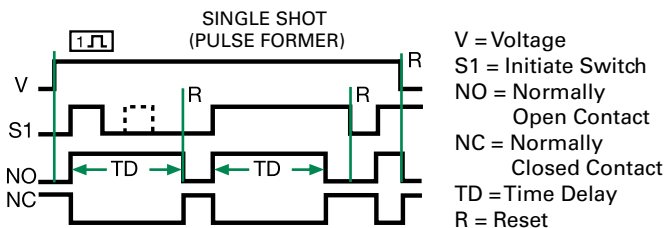

### Specifications

<b>Time Delay Range</b>	0.1s - 1000m in 6 adjustable ranges or fixed
<b>Repeat Accuracy Tolerance (Factory Calibration)</b>	±0.5% or 20ms, whichever is greater
<b>Reset Time</b>	≤ ±1%
<b>Initiate Time</b>	≤ 150ms
<b>Time Delay vs Temp. &amp; Voltage</b>	≤ 20ms
<b>Input Voltage Tolerance</b>	≤ ±2%
<b>Power Consumption</b>	12 or 24VDC; 24, 120, or 230VAC
<b>AC Line Frequency/DC Ripple</b>	±15%
<b>Output Type</b>	AC ≤ 2VA; DC ≤ 1W
<b>Form</b>	50/60 Hz / ≤ 10%
<b>Maximum Load Current</b>	Solid state
<b>Voltage Drop</b>	NO, closed during timing
<b>Off State Leakage Current</b>	1A steady state, 10A inrush at 60°C
<b>DC Operation</b>	AC ≅ 2.5V @ 1A; DC ≅ 1V @ 1A
<b>Protection</b>	AC ≅ 5mA @ 230VAC; DC ≅ 1mA
<b>Circuitry</b>	Positive or negative switching
<b>Dielectric Breakdown</b>	Encapsulated
<b>Insulation Resistance</b>	≥ 2000V RMS terminals to mounting surface
<b>Polarity</b>	≥ 100 MΩ
<b>Mechanical</b>	DC units are reverse polarity protected
<b>Mounting Dimensions</b>	Surface mount with one #10 (M5 x 0.8) screw
<b>Termination</b>	<b>H</b> 50.8 mm (2.0"); <b>W</b> 50.8 mm (2.0");
<b>Environmental</b>	<b>D</b> 30.7 mm (1.21")
<b>Operating/Storage Temperature</b>	0.25 in. (6.35 mm) male quick connect terminals
<b>Humidity</b>	-40° to 75°C / -40° to 85°C
<b>Weight</b>	95% relative, non-condensing
	≅ 2.4 oz (68 g)