

EVAL-AD5040EB/EVAL-AD506xEB

FEATURES

- Full-featured evaluation board for the AD5040/AD506x
- Operates from single 2.7 V to 5.5 V supplies
- On-board reference
- Direct hookup to USB port of PC
- PC software for control of DAC
- Power-on reset to midscale or zero scale
- 3 power-down functions

PACKAGE CONTENTS

- AD5040/AD506x evaluation board
- AD5040/AD506x device
- 3 V reference (ADR423)
- CD including
 - Self-installing software that allows you to control the DAC and exercise all functions of the device
 - Electronic version of device data sheet
 - Electronic version of EVAL-AD5040EB/EVAL-AD506xEB data sheet
- OP97 op amp (provided with EVAL-AD5063 only)

GENERAL DESCRIPTION

This data sheet describes the evaluation board for evaluating the AD5040, AD5060, AD5061, AD5062, and AD5063 *nano*DACs. These devices are low power, single 14-/16-bit buffered voltage-out DACs. Operating from single 2.7 V to 5.5 V supplies, the devices are well suited to battery-powered and other applications.

The AD5040/AD506x devices offer a relative accuracy specification of ± 1 LSB and operation is guaranteed monotonic with a ± 1 LSB DNL specification.

The AD5040 and AD506x devices use a versatile 3-wire serial interface that operates at clock rates up to 30 MHz and are compatible with standard SPI®, QSPI™, MICROWIRE™, and DSP interface standards. The reference for the AD5040 and AD506x devices is supplied from an external V_{REF} pin. A reference buffer is also provided on-chip. The AD5040/AD506x incorporate a power-on reset circuit that ensures the DAC output powers up to midscale or zero scale and remains there until a valid write occurs.

The AD5040 and the AD506x devices contain a power-down feature that reduces the current consumption of the device and provides software-selectable output loads while in power-down mode. The AD5061 is a low power, single 16-bit buffered voltage-out DAC. The AD5061 part offers a relative accuracy specification of ± 4 LSB, and operation is guaranteed monotonic with a ± 1 LSB DNL specification. The AD5063 is a low power, single 16-bit buffered voltage-out DAC and comes with on-board resistors in a 10-lead MSOP, allowing bipolar signals to be generated with an output amplifier. The AD5062 is a low power, single 16-bit unbuffered voltage-out DAC. The AD5062 offers a relative accuracy specification of ± 1 LSB, and operation is guaranteed monotonic with a ± 1 LSB DNL specification. An external reference can also be applied via an SMB input connector. The evaluation board is powered via terminal blocks.

FUNCTIONAL BLOCK DIAGRAM

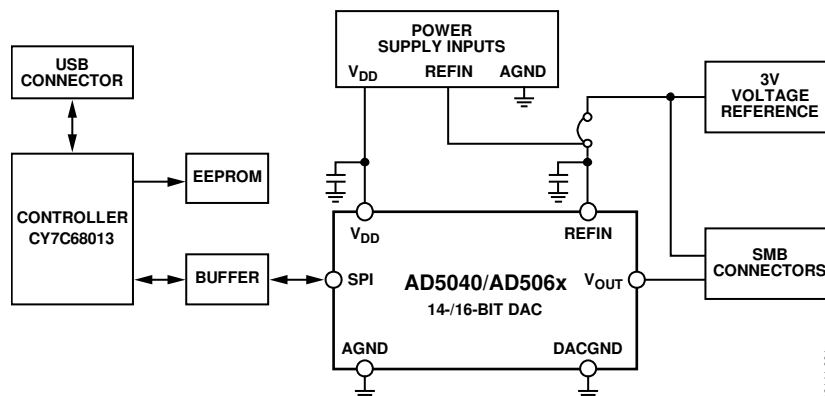

Figure 1.

Rev. 0

Information furnished by Analog Devices is believed to be accurate and reliable. However, no responsibility is assumed by Analog Devices for its use, nor for any infringements of patents or other rights of third parties that may result from its use. Specifications subject to change without notice. No license is granted by implication or otherwise under any patent or patent rights of Analog Devices. Trademarks and registered trademarks are the property of their respective owners.

TABLE OF CONTENTS

Features	1	Installing the Software	4
Package Contents	1	Operating the Software.....	4
General Description	1	Schematics and Artwork	5
Functional Block Diagram	1	PCB Layers for EVAL-AD5040EB/EVAL-AD5060EB/ EVAL-AD5061EB/EVAL-AD5062EB.....	8
Revision History	2	PCB Layers for EVAL-AD5063EB	9
Evaluation Board Hardware	3	Ordering Information.....	10
Evaluation Board Link Configuraton	3	Bills of Materials	10
Setup Conditions.....	3	Ordering Guide	12
Evaluation Board Interfacing.....	3	ESD Caution.....	12
Sockets	3		
Connectors	3		
Evaluation Board Software	4		

REVISION HISTORY

7/06—Revision 0: Initial Version

EVALUATION BOARD HARDWARE

The evaluation board for the AD5040/AD506x requires a single positive supply (+2.7 V to +5.5 V). The evaluation board for the AD5063 requires a single negative supply, such as -5 V, for the external on-board op amp in order to generate a bipolar signal. A +5 V_{DD} and -5 V_{SS} supply are required to power the output amplifier in the AD5063, if the user requires a bipolar signal. The +5 V V_{DD} is used to power the DAC. All supplies are decoupled to ground with 10 μF tantalum and 0.1 μF ceramic capacitors.

EVALUATION BOARD LINK CONFIGURATON

The three link options (LK1, LK2, and LK3) must be set before using the evaluation board.

LK1

This sets the power to the Cypress USB microcontroller that controls the USB section of the chip. The supply for the microcontroller can be provided from an external supply or from the computer via the USB interface. Using the computer to set the supply, set Link 1 to Position A. To use an external supply, set the link to Position B.

LK2

Link 2 connects the on chip reference to the Reference pin on the DAC. If you are using the ADR423 to provide the reference to the DAC, then Link 2 must be set.

LK3

Link 3 is normally connected. This shows proper connection of the USB chip.

SETUP CONDITIONS

Care should be taken before applying power and signals to the evaluation board to ensure that all link positions are as per the required operating mode. Table 1 shows the position in which all the links are set when the evaluation board is packaged.

Table 1. Initial Link and Switch Positions

Link No.	Initial Position	Function
LK1	Set to Position A	Power supplied from computer.
LK2	Closed	Reference supplied to Reference pin from ADR423.
LK3	Closed	USB cable connected.

EVALUATION BOARD INTERFACING

The AD5040/AD5060/AD5061/AD5062 have 8 pins while the AD5063 has 10 pins as described in Table 2. Note that the last two entries in Table 2 (Pin INV and Pin R_{FB}) apply only to the AD5063. Communication to the devices is accomplished via the Cypress CY7C63013 microcontroller Pin 45, Pin 46, and Pin 47.

Table 2. AD5040/AD506x Pin Configuration

Mnemonic	Function
V _{DD}	Power supply input. Devices can operate from 2.7 V to 5.5 V and V _{DD} , and should be decoupled to GND.
V _{REF}	Reference voltage input.
DACGND	Ground input to the DAC.
V _{OUT}	Analog output voltage from DAC.
SYNC	Level triggered control input (active low). This is the frame synchronization signal for the input data. When SYNC goes low, it enables the input shift register and data is transferred in on the falling edges of the following clocks. The DAC is updated following the 16 th clock cycle unless SYNC is taken high <u>before</u> this edge in which case the rising edge of SYNC acts as an interrupt and the write sequence is ignored by the DAC.
SCLK	Serial clock input. Data is clocked into the input shift register on the falling edge of the serial clock input. Data can be transferred at rates up to 30 MHz.
D _{IN}	Serial data input. This device has a 16-/24-bit shift register. Data is clocked into the register on the falling edge of the serial clock input.
AGND	Ground reference point for analog circuitry on part.
INV ¹	Connected to the internal scaling resistors of the DAC. Connect the INV pin to the external op amp's inverting input in bipolar mode.
R _{FB1} ¹	Feedback resistor. In bipolar mode, connect this pin to the external op amp circuit.

¹ For AD5063 only.

SOCKETS

The J3 and J6 sockets are described in Table 3.

Table 3. Socket Functions

Socket	Function
J3	Subminiature BNC socket for the DAC output.
J6	Subminiature BNC socket for the reference output.

CONNECTORS

The evaluation board connectors are described in Table 4.

Table 4. Connector Function

Connector	Functions
J1	USB connector.
J2	PCB-mounting terminal block. Supplies the digital power supply to the microcontroller.
J3, J6	PCB-mounting SMB connector. Provides connection to on-board reference output voltage.
J4, J7 ¹	PCB-mounting terminal block. Provides the reference power supply.
J5	PCB-mounting terminal block. Provides the power supply to the AD5040/AD506x.
J9 ¹	PCB-mounting terminal block. Provides connection to the DAC R _{FB} pin.

¹ For AD5063 only.

EVALUATION BOARD SOFTWARE

INSTALLING THE SOFTWARE

The AD5040/AD506x evaluation kit includes self-installing software on CD-ROM. The software is compatible with Microsoft® Windows® 95 or higher.

Install the evaluation board software before connecting the evaluation board to the USB port of the PC. This ensures the evaluation board is correctly recognized when connected to the PC.

1. Start the Windows operating system and insert the CD-ROM.

The installation software launches automatically. If it does not, use Windows Explorer to locate the file **setup.exe** on the CD-ROM. Select this file to start the installation procedure.

2. At the prompt, select a destination directory, which is **C:\Program Files\Analog Devices\AD506X** by default.

Once the directory is selected, the installation procedure copies the files into the relevant directories on the hard drive. The installation program creates a program group called **Analog Devices** with subgroup **AD506X** in the **Start** menu of the taskbar.

OPERATING THE SOFTWARE

1. Once the installation procedure is complete, select the **AD5040/60/61/62/63 icon** to start the program.
2. Choose the part to be tested as shown in Figure 2.



Figure 2. Device Selection

3. Select how the device should operate. Choose **Normal** to operate the device in normal mode. For power-down mode, choose one of the three available options (**Tri-State**, **100 kOhm to GND** or **1 kOhm to GND**) as shown in Figure 3.
4. Enter the DAC code in either decimal or hex code. Select the field populated with zeroes (**0000**) for decimal or **Hex** for hex. The AD5040 accepts a 16-bit command whereas AD506x accepts a 24-bit command.
5. Select **Update DAC** to update DAC output.



Figure 3. DAC Operation Selection

SCHEMATICS AND ARTWORK

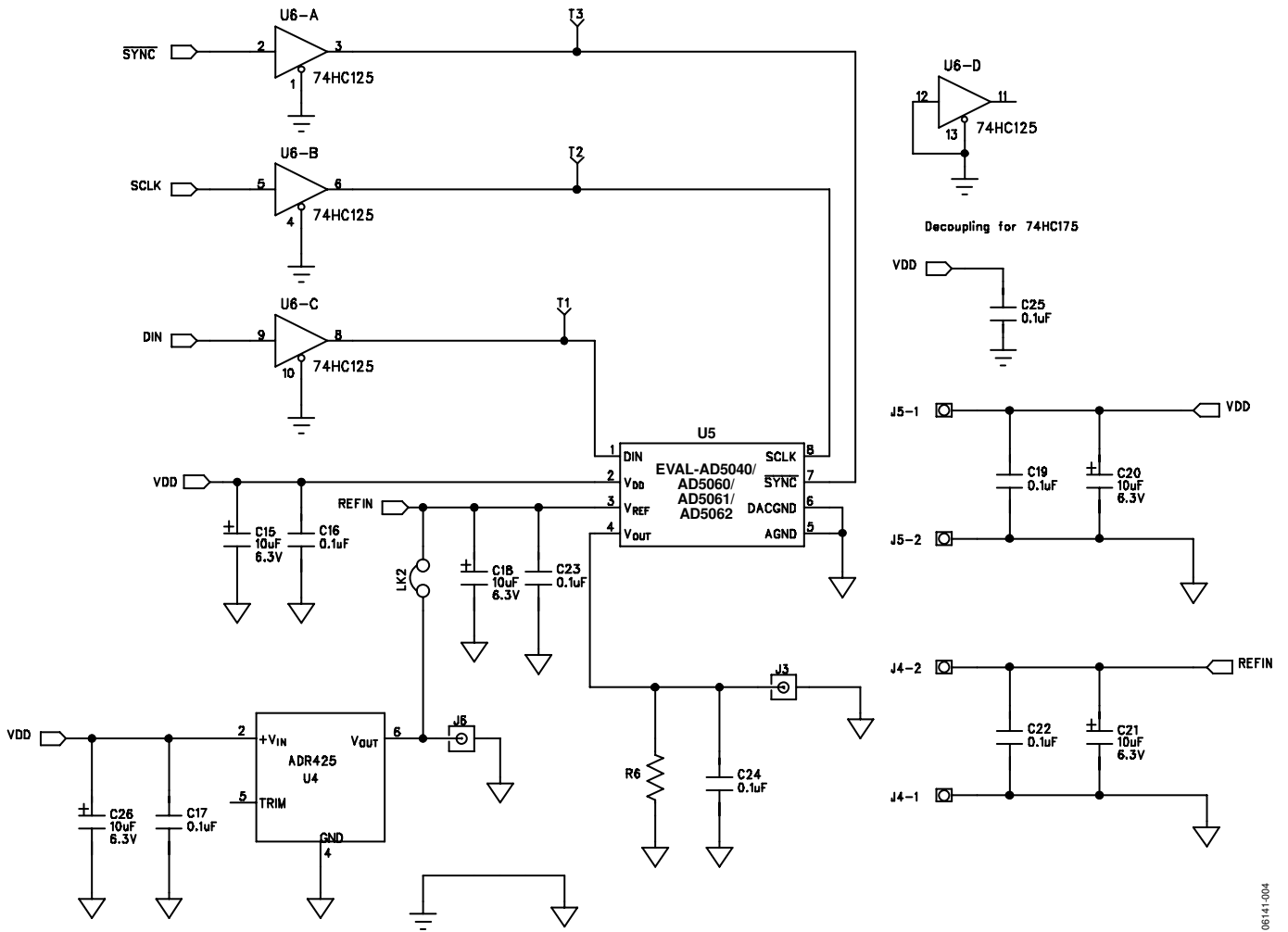

Figure 4. Evaluation Board Schematic for EVAL-AD5040/AD5060/AD5061/AD5062

06141-004

EVAL-AD5040EB/EVAL-AD506xEB

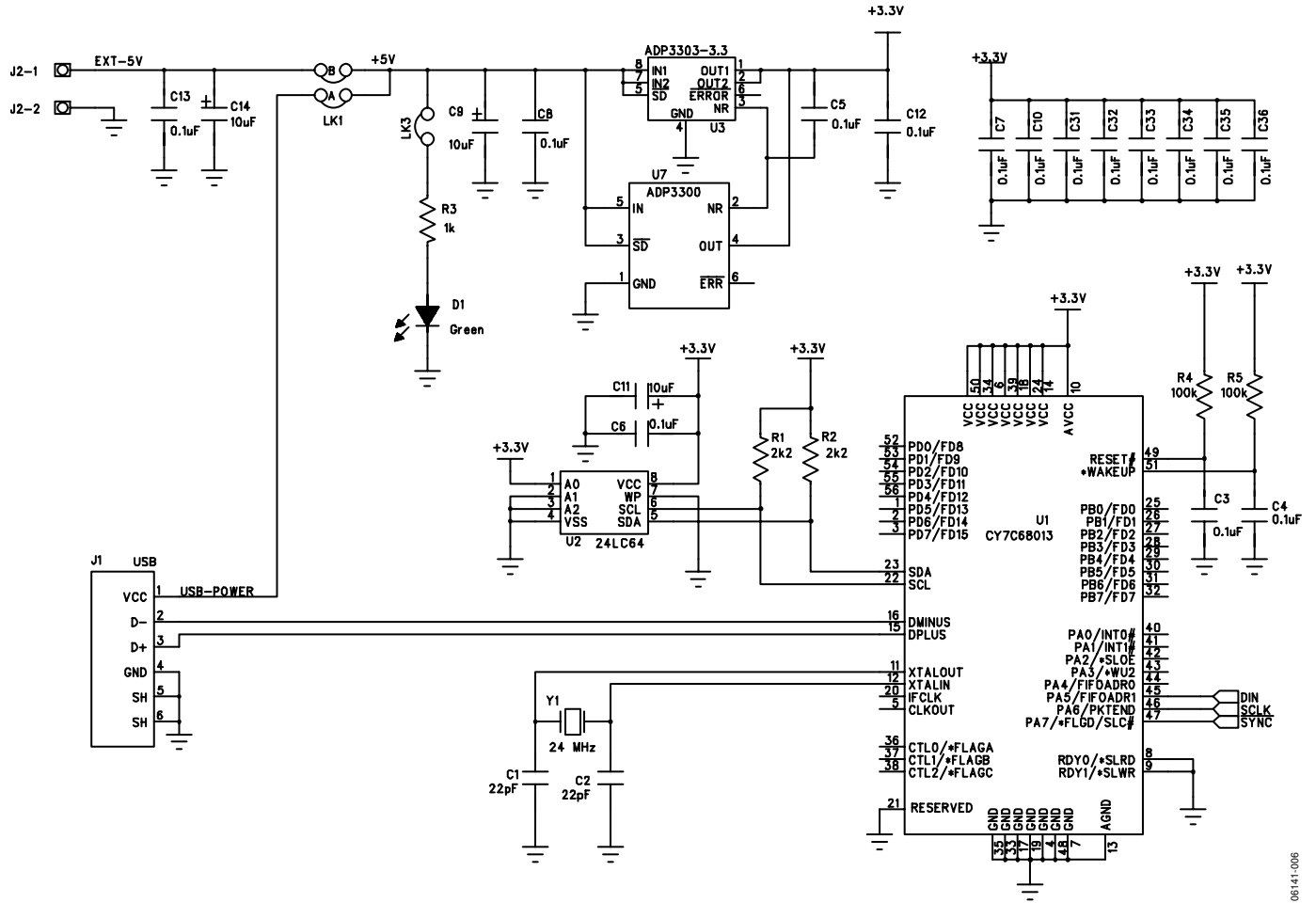
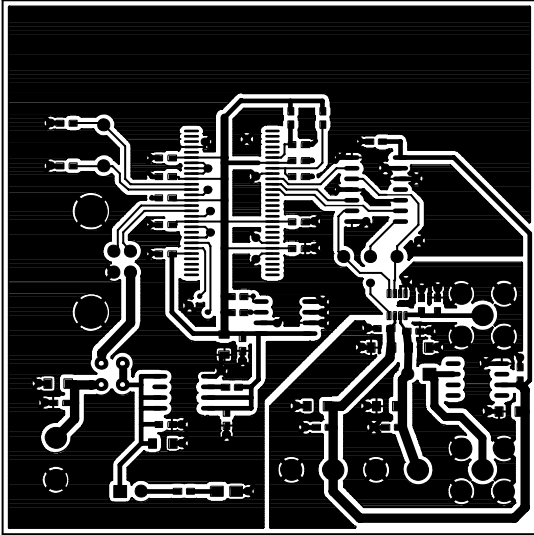

Figure 6. Evaluation Board Schematic for AD5040/AD506x Controller

06141-006

EVAL-AD5040EB/EVAL-AD506xEB

PCB LAYERS FOR EVAL-AD5040EB/EVAL-AD5060EB/EVAL-AD5061EB/EVAL-AD5062EB



06141-011

Figure 7. EVAL-AD5040EB/AD5060EB/AD5061EB/AD5062EB—
Component Side Artwork

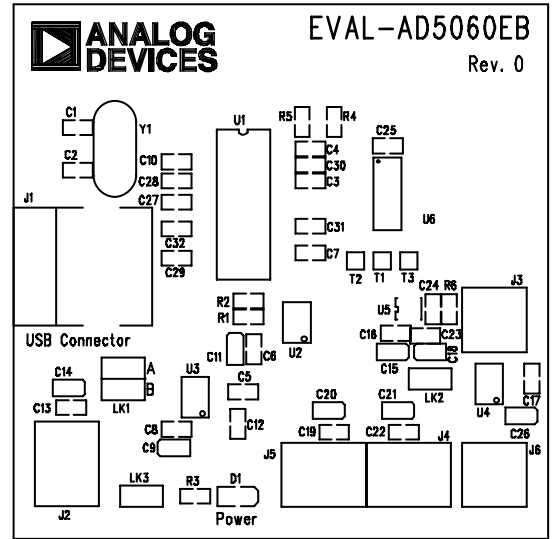

06141-010

Figure 9. EVAL-AD5040EB/AD5060EB/AD5061EB/AD5062EB—
Component Side View (Top)

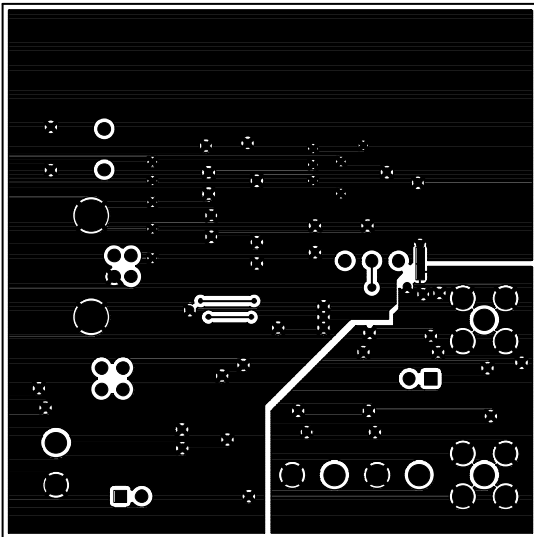

06141-012

Figure 8. EVAL-AD5040EB/AD5060EB/AD5061EB/AD5062EB—
Solder-Side Artwork

PCB LAYERS FOR EVAL-AD5063EB

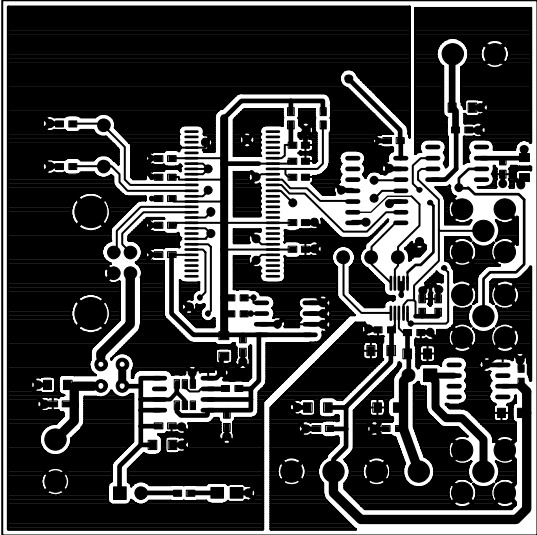

Figure 10. EVAL-AD5063EB—Component Side Artwork

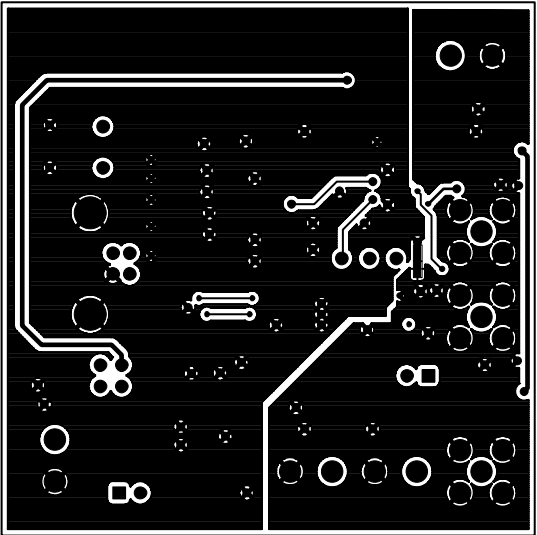

Figure 11. EVAL-AD5063EB—Solder-Side Artwork

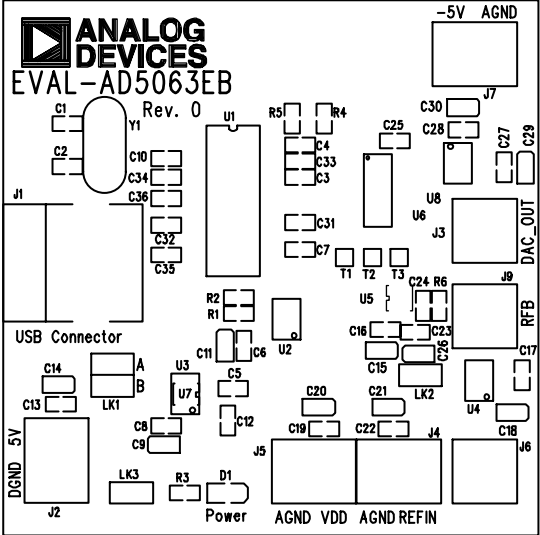

Figure 12. EVAL-AD603EB—Component Side View (Top)

EVAL-AD5040EB/EVAL-AD506xEB

ORDERING INFORMATION

BILLS OF MATERIALS

Table 5. EVAL-AD5040EB/EVAL-AD5060EB/EVAL-AD5061EB/EVAL-AD5062EB Bill of Materials

Qty.	Name	Part Type	Part Description	Stock Code
2	C1, C2	Capacitor	603	FEC 722-005
24	C3 to C8, C10, C12, C13, C16, C17, C19, C22 to C25, C27, C28, C31 to C36	Capacitor	603	FEC 499-675
10	C9, C11, C14, C15, C18, C20, C21, C26, C29, C30	Capacitor (tantalum, polarized)	CAP\TAJ_A	FEC 197-014
1	D1	LED	LED-0805	FEC 359-9681
1	J1	USB	USB_RECPTACLE_B	FEC 152-754
6	J2, J4-1, J4-2, J5-1, J5-2, J7	Power connector	CON\POWER	FEC 151-785
3	J3, J6, J9	SMA	PCB Jack	FEC 310-682
1	LK1	Jumper_2	Jumper_2	FEC 148-535 and FEC 150-411 (36-pin strip)
2	LK2, LK3	Jumper	SIP-2P	FEC 511-705 and FEC 150-411 (36-pin strip)
3	R1, R2, R6	Resistor	603	FEC 911-276
1	R3	Resistor	603	FEC 911-239
2	R4, R5	Resistor	603	FEC 911-471
3	T1, T2, T3	Testpoint	Testpoint	FEC 240-333
1	U1	CY7C68013	SSOP56	Digikey 428-1332-ND
1	U2	24LC64	SO8NB	Digikey 24LC64B-1/SN-ND
1	U3	ADP3303-3.3	3.3 V Regulator	ADP3303AR-3.3
1	U4	ADR425	SO8NB	ADR425
1	U5	AD5040/AD5060/AD5061/AD5062	MSO10	AD5040/AD5060/AD5061/AD5062
1	U6	74HC125	Quad Buffer	FEC 492-395
1	U7	ADP3303	3.3 V Regulator	ADP3303AR-3.3
1	Y1	XTAL	HC49	FEC 569-860

Table 6. EVAL-AD5063EB Bill of Materials

Qty.	Name	Part Type	Part Description	Stock Code
2	C1, C2	Capacitor	603	FEC 722-005
24	C3 to C8, C10, C12, C13, C16, C17, C19, C22 to C25, C27, C28, C31 to C36	Capacitor	603	FEC 499-675
10	C9, C11, C14, C15, C18, C20, C21, C26, C29, C30	Capacitor+	CAP\TAJ_A	FEC 197-014
1	D1	LED	LED-0805	FEC 359-9681
1	J1	USB	USB_RECPTACLE_B	FEC 152-754
4	J2, J4, J5, J7	Power connector	CON\POWER	FEC 151-785
3	J3, J6, J9	SMA	PCB Jack	FEC 310-682
1	LK1	Jumper_2	Jumper_2	FEC 148-535 and FEC 150-411 (36-pin strip)
2	LK2, LK3	Jumper	SIP-2P	FEC 511-705 and FEC 150-411 (36-pin strip)
3	R1, R2, R6	Resistor	603	FEC 911-276
1	R3	Resistor	603	FEC 911-239
2	R4, R5	Resistor	603	FEC 911-471
3	T1, T2, T3	Testpoint	Testpoint	FEC 240-333
1	U1	CY7C68013	SSOP56	Digikey 428-1332-ND
1	U2	24LC64	SO8NB	Digikey 24LC64B-1/SN-ND
1	U3	ADP3303-3.3	SO8NB	ADP3303AR-3.3
1	U4	ADR423	SO8NB	ADR425
1	U5	AD5063BRMZ	MSO10	AD5063BRMZ
1	U6	74HC125	Quad Buffer	FEC 492-395
1	U7	ADP3303	3.3 V Regulator	ADP3300ART-5
1	U8	OP97	SO8NB	OP97FS
1	Y1	XTAL	HC49	FEC 569-860

EVAL-AD5040EB/EVAL-AD506xEB

ORDERING GUIDE

Model	Description
EVAL-AD5040EB	Evaluation Board
EVAL-AD5060EB	Evaluation Board
EVAL-AD5061EB	Evaluation Board
EVAL-AD5062EB	Evaluation Board
EVAL-AD5063EB	Evaluation Board

ESD CAUTION

ESD (electrostatic discharge) sensitive device. Electrostatic charges as high as 4000 V readily accumulate on the human body and test equipment and can discharge without detection. Although this product features proprietary ESD protection circuitry, permanent damage may occur on devices subjected to high energy electrostatic discharges. Therefore, proper ESD precautions are recommended to avoid performance degradation or loss of functionality.

