

REV	DATE	DESCRIPTION	BY	CHK	APP
AA	22				
B	ECO-08-030952		21NOV2008	VL	LR
B1	REVISED PER ECO-08-024927		09NOV2008	KK	AEG

MECHANICAL:

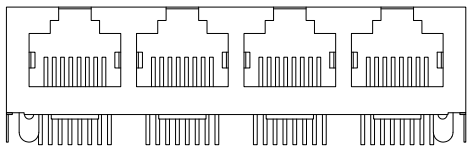

P/N 6610055-3 SHOWN  
NO PANEL GROUNDS

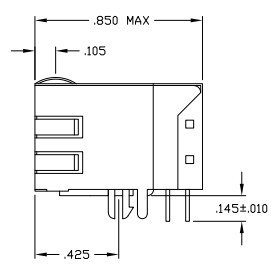
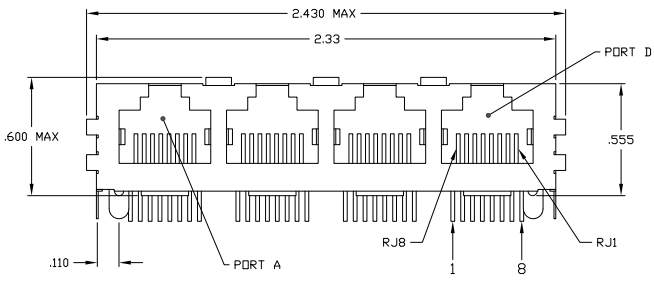
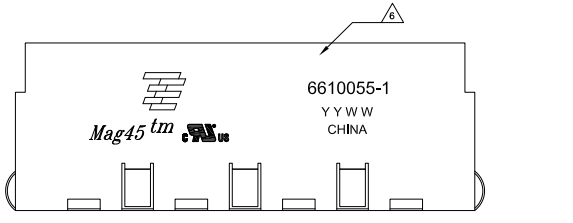
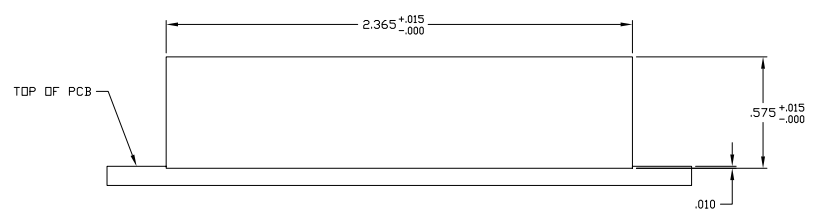

1X4 SUGGESTED PANEL CUTOUT

- △ MATERIALS:
  - HOUSING - THERMOPLASTIC PET POLYESTER FLAMMABILITY RATING UL 94V-0
  - SHIELD - .010" THICK, C26800 BRASS PREPLATED WITH 30μINCH MIN SEMI-BRIGHT NICKEL
  - SOLDER TABS POST DIPPED WITH 100μINCH MIN SAC SOLDER
  - MOD JACK CONTACTS - 0.0157 X 0.018" PHOSPHOR BRONZE, 50μINCH MIN OVERALL NICKEL UNDERPLATE WITH SELECT 50μINCH MIN HARD GOLD FINISH PLATE. SOLDER TAILS WITH 100μINCH MIN MATTE TIN AND/OR SAC SOLDER DIP.
- △ RJ45 JACK CAVITY CONFORMS TO FCC RULES AND REGULATIONS PART 68, SUB PART F.
- △ MAGNETICS
  - IMPEDANCE: 100 OHMS
  - TURNS RATIO (CHIP-CABLE): TX = 11, RX = 11
  - OPEN CIRCUIT INDUCTANCE (OCLL) 350μH MIN @100kHz, 0.1VRMS, 8mADC BIAS FROM 0°C TO 70°C, TX AND RX
  - PERFORMANCE @ 25°C:
    - INSERTION LOSS (IL): 1.1dB MAX FROM 0.5MHz TO 100MHz
    - RETURN LOSS (RL): 18dB MIN FROM 0.5MHz TO 30MHz
    - 18-20LOG(f/30)dB MIN FROM 30 MHz TO 60MHz
    - 12dB MIN FROM 60.1MHz TO 80MHz
    - CROSSTALK ATTENUATION: 35dB MIN FROM 0.5MHz TO 40MHz
    - 33-20\*LOG(f/50)dB MIN FROM 40.1MHz TO 100MHz
    - COMMON MODE REJECTION RATIO (CMRR): 30dB MIN FROM 0.5MHz TO 100MHz
  - ISOLATION VOLTAGE: COMPLIES WITH IEEE802.3 2002, PARA 23.5.11, ITEM b.
- 4 OPERATING TEMPERATURE: FROM 0°C TO +70°C
- △ INDICATED CONNECTIONS ARE FOR HUB CONFIGURATION. THE MAGNETICS ARE SYMMETRICAL, AND SUPPORT AUTO-MDIX/MOIX.
- △ TYCO ELECTRONICS LOGO, PART NUMBER, DATE CODE, COUNTRY OF ORIGIN AND AGENCY APPROVAL MARKING IN APPROXIMATE LOCATION SHOWN.
- 7 THESE PARTS ARE RECOMMENDED FOR WAVE SOLDERING PROCESS, PREHEAT TEMPERATURE IS 120°C TO 160°C, 120 SECONDS TO 180 SECONDS, PEAK WAVE SOLDERING TEMPERATURE IS 260°C MAX, 10 SECONDS MAX.
- △ OBSOLETE PARTS: OBSOLETE CIS STREAMLINING PER D.RENAUD/D.SINISI

△ OBSOLETE	0	6610055-3
	7	6610055-1
		PANEL GROUND TABS
		PART NUMBER

THIS DRAWING IS A CONTROLLED DOCUMENT.

REVISIONS	DATE	BY	CHK	APP
1				
2				
3				
4				
5				
6				
7				
8				

1x4 MAG45(TM) MODULAR JACK, 7K1 SCHEMATIC, 768K1 SERIES CIRCUIT, SHIELDED, OPTIONAL PANEL GROUND TABS, DECOUPLING CAPACITOR, NO LEADS

108-2100

DATE: 08/03/08

REV: 7

REVISED PER ECO-08-024927

09NOV2008

KK

AEG

CUSTOMER DRAWING

SCALE: 4:1

SHEET 1 OF 2

B1

ELECTRICAL:

766K1 SERIES MAGNETIC CIRCUIT  $\Delta/\Delta$   
 PORTS A & C

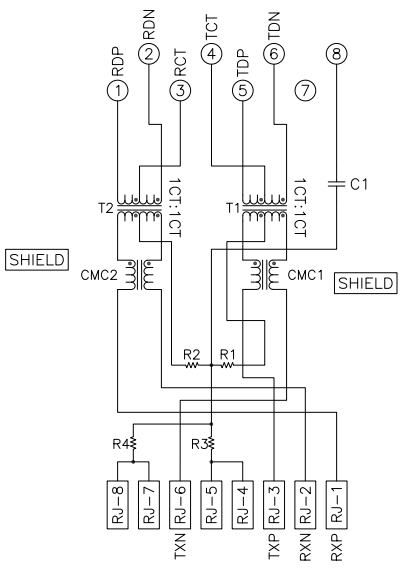

766K1 SERIES MAGNETIC CIRCUIT  $\Delta/\Delta$   
 PORTS B & D

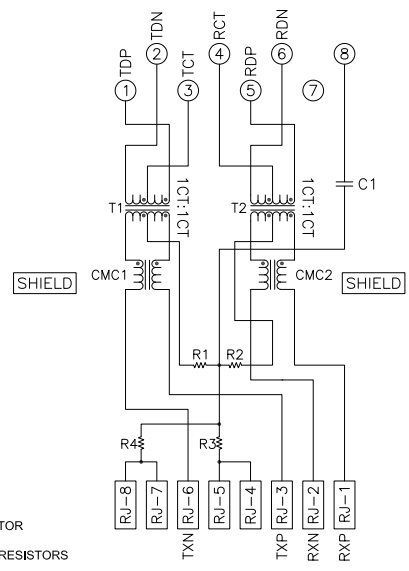

C1 = 1000 pF, 2kV CAPACITOR  
 R1-R4 = 75 OHMS, 1/16 W RESISTORS

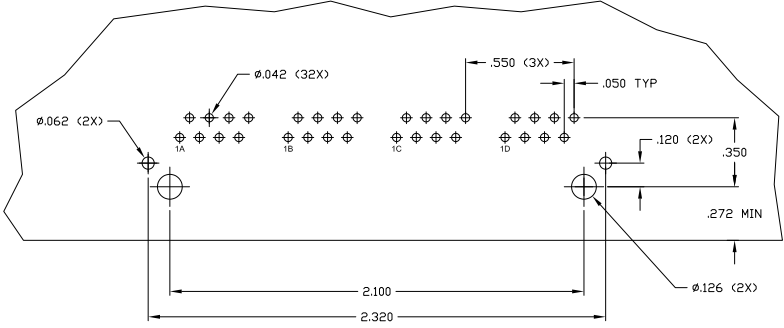

SUGGESTED PCB LAYOUT  
 (Component Side)

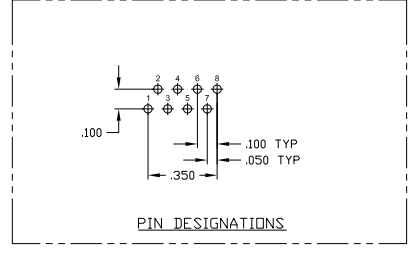

THIS DRAWING IS A CONTROLLED DOCUMENT.		DATE	BY	REVISION
DRAWN BY: [Signature]		10B-2100	10B-2100	10B-2100
CHECKED BY: [Signature]		10B-2100	10B-2100	10B-2100
APPROVED BY: [Signature]		10B-2100	10B-2100	10B-2100
CUSTOMER DRAWING		A100779	G=6610055	REV 2