

CUSTOMER DRAWING

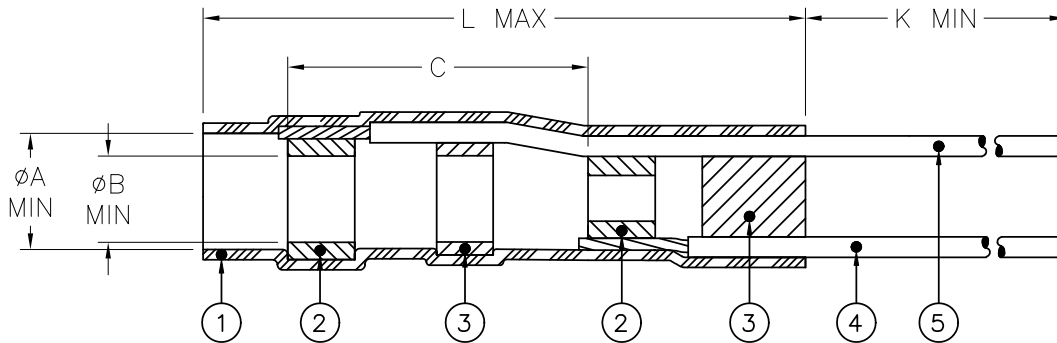

Product Dimensions						Cable Dimensions				
Product Name	øA min	øB min	C±1.3 (C±.05)	L±1.5 (L±.06)	K min	øD	øE	øF min	G±0.5 (G±.02)	M±0.5 (M±.02)
D-133-06	4.95 (.195)	4.70 (.185)	12.7 (.50)	28 (1.10)	150 (5.905)	2.3 (.090) to 4.95 (.195)	1.9 (.075) to 4.70 (.185)	0.3 (0.015)	19 (0.748)	6 (0.235)

MATERIAL

- INSULATION SLEEVE: Heat-shrinkable, transparent blue, radiation cross-linked modified polyvinylidene fluoride.
- SOLDER PREFORM WITH FLUX:
SOLDER: TYPE Sn63 per ANSI-J-STD-006.
FLUX: TYPE ROL0 per ANSI-J-STD-004.
- MELTABLE INSERTS: Thermally stabilized thermoplastic.
- CONDUCTOR LEAD: Raychem 55A0111-22-9 in accordance with MIL-W-22759/32, AWG 22, stranded tin plated copper. Color: white.
- GROUND LEAD: Raychem 55A0111-22-0 in accordance with MIL-W-22759/32, AWG 22, stranded tin plated copper. Color: black.

APPLICATION

- This controlled soldering device is designed for termination of a coaxial cable to a connector, printed circuit board, etc. It will terminate tin or silver plated copper center conductor and single or double tin or silver plated copper braid of a coaxial cable, having an insulation rated for at least +125°C.
- Temperature range: -55°C to +150°C. For installation procedure, RPIP-500-03.

For best results, prepare the cable as shown:

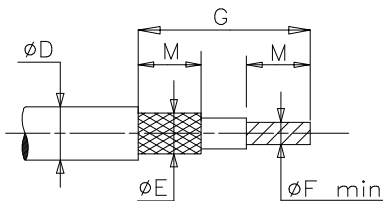

© 1998-2020 TE CONNECTIVITY Corporation. All Rights Reserved.

				TITLE: COAXIAL SOLDERSLLEEVE DEVICE with Pre-Installed Stranded Wires	
Unless otherwise specified, dimensions are in millimeters. [Inches dimensions are shown in brackets]			Raychem Devices		DOCUMENT NUMBER: D-133-06
TOLERANCES: 0.00 N/A 0.0 N/A 0 N/A	ANGLES: N/A ROUGHNESS IN MICRON	TE Connectivity reserves the right to amend this drawing at any time. Users should evaluate the suitability of the product for their application.		DOCUMENT REVISION: D	REVISION ISSUE DATE: 12-MAR-2020
DRAWN BY: M. FORONDA	DRAWN DATE: 24-JUL-1998	CAGE CODE: 09090	ECO NUMBER: ECO-20-003669	SCALE: None	SIZE: A SHEET: 1 of 1