

# Product Abstract

## MLX81150

### LIN-Slave for relay and DC motor control

#### Features

##### Microcontroller: MLX16x8 RISC CPU

- 16 bit RISC-CPU
- Co-processor for fast multiplication and division
- In-circuit debug and emulation

##### Memories

- 32 kByte Flash with ECC
- 2 kByte RAM
- 380 Byte EEPROM with separate RAM (also called NVRAM), with ECC, for customer purposes

##### Supported bus interface

- LIN-Interface with integrated LIN transceiver supporting LIN 2.x and SAE J2602, certified LIN protocol software provided by Melexis
- In-Module-Programming (Flash and EE) via pin LIN using a special Melexis fast protocol
- PWM-Interface
- Full duplex SPI, Master/Slave, double-buffered, speed programmable

##### Voltage regulator

- Internal voltage regulator, direct powered from 12V battery supply
- Operating voltage  $V_S = 5.5V$  to 18V, IC will work down to 3.9V
- Possibility to put an external bypass transistor for high temperature requirements
- Very low SLEEP MODE current  $< 30\mu A$ , Wake up by LIN traffic or local sources

##### Periphery

- 4 programmable 16bit PWM modules for external transistor full bridge applications
- Timer unit 16 bit with 4 capture and 4 compare
- 25 MHz  $\pm 5\%$  internal RC-oscillator with PLL, optional crystal resonator
- Load dump and brown out interrupt function
- Digital watchdog for software flow tracking
- System-Clock-independent fully integrated watchdog
- On-chip temperature sensor with  $\pm 10K$  accuracy
- 10 bit ADC with  $< 6 \mu s$  conversion time with multiple channels and different ADC references, DMA access to RAM
- 8 multiple purpose I/Os
- 2 integrated relay drivers with free wheel function
- 2 inputs for relay contact or shunt current monitoring
- Over current detection, shunt current sense
- 1 switch-able supply output for external Hall sensor connection

##### Additional features

- Direct access to pin LIN possible
- Temperature range  $-40^\circ C$  up to  $150^\circ C$  ambient
- 28V jump start and 45V load dump protected
- Monolithic solution: Single chip in single package realization
- Small QFN32 5x5

# Product Abstract

## MLX81150

### LIN-Slave for relay and DC motor control

## Applications

LIN slaves for all kind of high current DC and 1 / 2 phase BLDC motor control, like

- Window lifter
- Sun roof
- DC oil, water and fuel pumps
- Throttle valves
- Automatic head lean
- DC/DC converters

## Ordering Information

Order Code <sup>[1]</sup>	Temperature Range	Package	Delivery	Remark
MLX81150 LLW-DAA-000-RE	-40 - 150 °C	QFN32 5x5	Reel	MLX81150D

Table 1 – Ordering Information

<sup>[1]</sup>.See Marking/Order Code.

# Product Abstract

**MLX81150**

**LIN-Slave for relay and DC motor control**

## Contents

<b>1. Functional Diagram .....</b>	<b>4</b>
<b>2. Pin Description .....</b>	<b>5</b>
<b>3. Electrical Characteristics.....</b>	<b>7</b>
3.1. Operating Conditions.....	7
3.2. Absolute maximum ratings .....	9
<b>4. Application Examples.....</b>	<b>11</b>
4.1. Single DC-Motor Drive .....	11
4.2. Single DC Motor Drive with soft start / stop .....	12
4.3. Single DC motor drive in FET controlled full bridge applications .....	13
4.4. LED-Lamp driver, switch mode power supply .....	14
4.5. MLX81150 in 1- and 2- phase BLDC (brush less DC) Motor control applications .....	15
4.6. Key inputs with different wetting currents in active and sleep configuration .....	16
<b>5. Mechanical Specification - Package data QFN32 .....</b>	<b>18</b>
<b>6. Marking/Order Code .....</b>	<b>19</b>
6.1. Marking MLX81150.....	19
6.2. Order Code MLX81150 .....	19
<b>7. Assembly Information.....</b>	<b>20</b>
<b>8. Contact.....</b>	<b>21</b>
<b>9. Disclaimer.....</b>	<b>21</b>

# Product Abstract

## MLX81150

### LIN-Slave for relay and DC motor control

#### 1. Functional Diagram

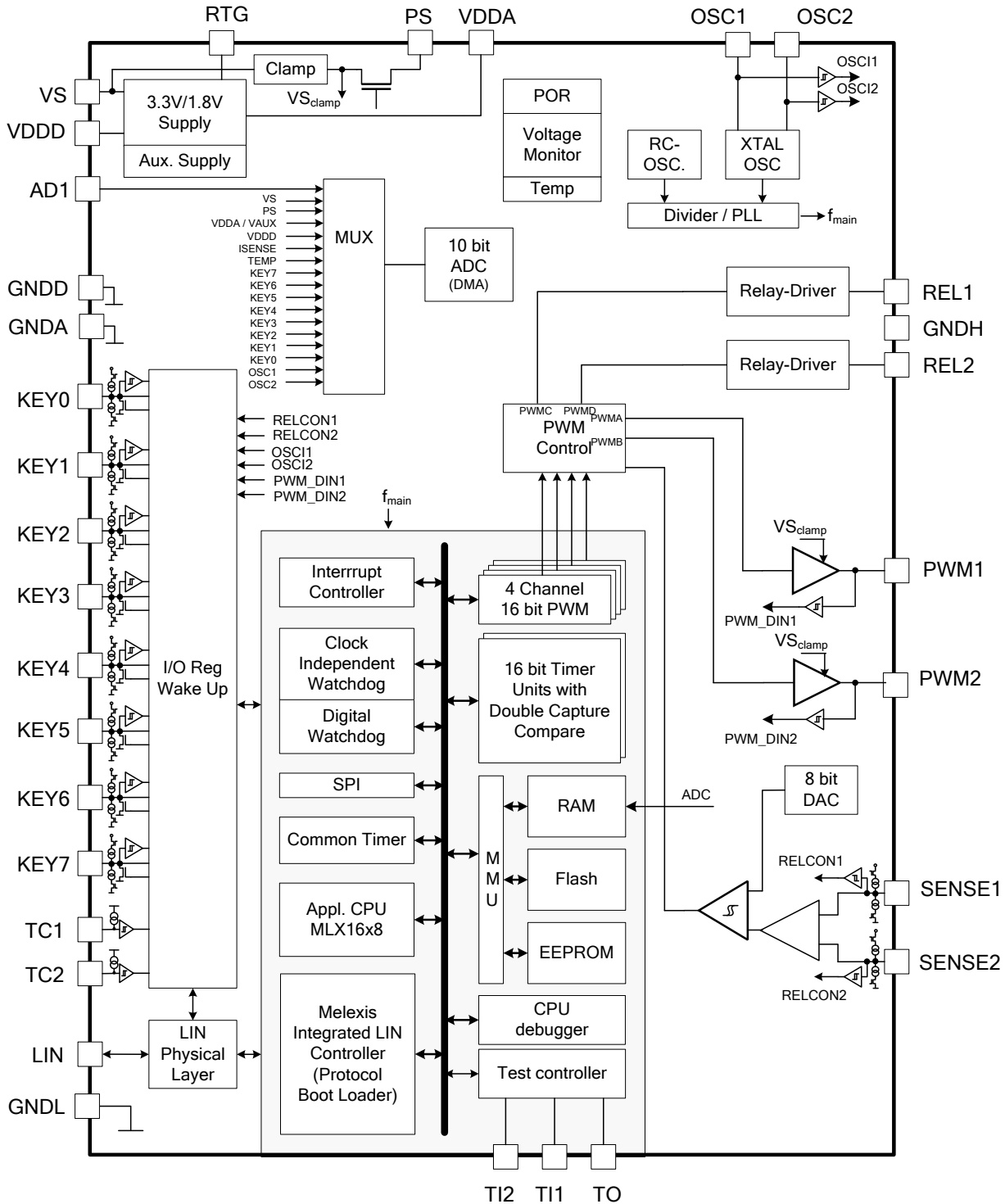

Figure 1: Block Diagram

# Product Abstract

## MLX81150

### LIN-Slave for relay and DC motor control

## 2. Pin Description

Pin No.	Pad count	Pin name	voltage range	remarks and description
30	1	VS	Pwr HV	Battery supply voltage; external protection against reverse polarity needed, external blocking capacitors
29	2	GNDD	Pwr	Ground pin for Digital part
27	2	GNDA	Pwr	Ground pin for Analogue part
12	2	GNDH	Pwr	Ground pin for Relay Driver
15	1	GNDL	Pwr	Ground pin for LIN
25	2	VDDA	Pwr LV	Regulator output (~3.3 V), external blocking capacitors
28	2	VDDD	Pwr LV	Regulator output (~1.8 V), external blocking capacitors
26	1	RTG	Ana LV	Output for external bipolar transistor in case of HT applications
32	1	PS	Ana HV	High-side switch with Ron < 40 Ohm at 20mA, Switch-able supply (<15 V) for external components
[3:10]	8	KEY[7:0]	Multi-function HV	High voltage I/O port with wake-up function, Input for high or low active switches, ADC input, Low-side driver output 2mA (15mA), Weak current sources for pin diagnosis and WAKE UP in SLEEP MODE SPI Interface Pins (valid for KEY[3:0], DI, DO, CLK, CS)
31	1	AD1	Ana HV	High voltage ADC input (for VBAT measurement), Low side driver 30 mA (only for test purposes)
13, 11	2, 2	REL[2:1]	Ana HV	Low-side switch with Ron < 7 Ohm at 150 mA @150°C, Relay driver with free wheel function, PWM controlled output
23, 24	2	SENSE[2:1]	Ana HV	High voltage input for read out the status of relay contacts, Current sense function for shunt current
2, 1	2	PWM[2:1]	Ana HV	Push pull output with Ron < 50 Ohm at 20mA, high output level is supply related but max approx. 14V, PWM controlled output
21, 22	2	TC[2:1]	Ana LV	Input for timer capture unit, Low voltage input
18, 19	2	OSC[2:1]	Ana LV	Crystal oscillator pin, Low voltage input, load capacitors external, ADC input
14	1	LIN	Ana HV	LIN 2.x transceiver BUS pin, slave only, High voltage I/O

# Product Abstract

## MLX81150

### LIN-Slave for relay and DC motor control

Pin No.	Pad count	Pin name	voltage range	remarks and description
17, 16	1	TI[2:1]	Dig input	Test inputs for Melexis, debug interface - connect via resistor to GND in application mode, so that Flashing via these test pins is possible
20	1	TO	Dig output	Test output for Melexis, debug interface, unconnected in application mode
-	-	not connected	-	not connected pins

Dig	digital input or output or bidirectional
Ana	analogue pin
Pwr	power/supply pin
Multifunction	multifunctional pin (configurable pin)
Test	pin for test purposes
LV	low voltage, VDDA or VDDD related
HV	high voltage, VBAT or VS related

Top view of the package QFN32

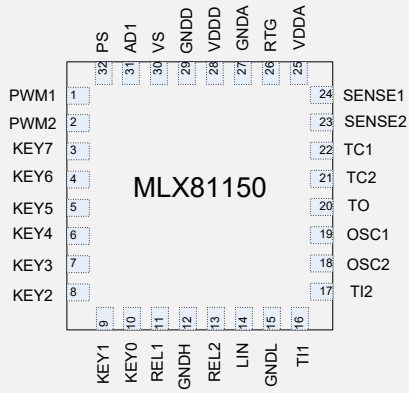

Table 3 – Ordering Information

# Product Abstract

## MLX81150

### LIN-Slave for relay and DC motor control

## 3. Electrical Characteristics

All voltages are referenced to ground (GND). Positive currents flow into the IC. The absolute maximum ratings given in the table below are limiting values that do not lead to a permanent damage of the device but exceeding any of these limits may do so. Long term exposure to limiting values may affect the reliability of the device. Reliable operation of the device is only specified within the limits shown in Operating Conditions.

### 3.1. Operating Conditions

The IC can have 6 different hardware modes. The exact functionality of these modes depends on the hardware and software configuration:

- **Reset:**
  - triggered by hardware. When VS or VDDA or VDDD drop below a critical level, the complete chip is powered down.
  - The analogue and digital supply regulators are disabled. No functionality is available in this mode.
- **Normal mode. Main application running**
  - Microcontroller fully functional
  - Analogue fully functional
- **Under voltage: triggered by the hardware under voltage detection interrupt. (VS\_UV)**
  - Microcontroller fully functional.
  - Analogue functionality under software control.
  - Reduced current capability on VDDA below VS=5.5V.
- **Over voltage: triggered by the hardware over voltage detection interrupt. (VS\_OV)**
  - Microcontroller fully functional
  - Analogue functionality powered down by hardware or software.
- **Sleep Mode: Triggered by the software.**
  - Microcontroller powered down
  - Digital and analogue supply powered down.
  - Sleep Mode and wake-up functionality running on help supply Vaux

Parameter	Symbol	Conditions	Limit		Unit
			Min	Typ	
Supply Voltage Range	VS		5.5 (3.9[1])		18 V
Ambient Temperature	Ta		-40		105 (150[2]) °C

Table 1: Operational conditions

# Product Abstract

## MLX81150

### LIN-Slave for relay and DC motor control

- [1] IC will work down to 3.9V with reduced analogue characteristics, Digital part still works, Memories will keep their content. Some analogue parameter will drift out of limits, but chip function can be guaranteed.  
Before going down to 3.9V the VS has to be at the startup of the IC for a certain time > 6V to guarantee a correct reset!  
Evaluation will only be done on sample basis in the preproduction phase; no production test; no life time test
- [2] With temperature applications at  $T_A > 105^\circ\text{C}$  a reduction of chip internal power dissipation with external supply transistor is obligatory. The extended temperature range is only allowed for a limited periods of time, customers mission profile has to be agreed by Melexis as an obligatory part of the Part Submission Warrant (PSW).  
Some analogue parameter may drift out of limits, but chip function can be guaranteed.



# Product Abstract

## MLX81150

### LIN-Slave for relay and DC motor control

#### 3.2. Absolute maximum ratings

Parameter	Symbol	Condition	Limit Min	Limit Max	Unit
Supply voltage	VS	t < 5 min	-0.3	28	V
		t < 500 ms	-0.3	45	
	VS.tr1	ISO 7637-2 pulse 1 [1] VS=13.5V, TA=(23 ± 5)°C	-100		
	VS.tr2	ISO 7637-2 pulse 2 [1] VS=13.5V, TA=(23 ± 5)°C		+50	
	VS.tr3	ISO 7637-2 pulses 3A, 3B [1] VS=13.5V, TA=(23 ± 5)°C	-150	+100	
	VS.tr5	ISO 7637-2 pulses 5b [1] VS=13.5V, TA=(23 ± 5)°C	+65	+87	
Output voltage	VDDA		-0.3	3.6	
Output voltage	VDDD		-0.3	1.95	
LIN Bus	VLIN	T < 500ms	-22	40	
	VLIN.tr1	ISO 7637-2 pulse 1 [2] VS=13.5V, TA=(23 ± 5)°C	-100		
	VLIN.tr2	ISO 7637-2 pulse 2 [2] VS=13.5V, TA=(23 ± 5)°C		+75	
	VLIN.tr3	ISO 7637-2 pulses 3A, 3B [2] VS=13.5V, TA=(23 ± 5)°C	-150	+100	
Voltage on Analogue HV	VANA_HV	Without external resistor; Pins KEY[7:0], AD1 Pin PWM[2:1]	-0.3	VS+0.3 V(PS) +0.3	
		With external resistor of 47 kΩ; Pins KEY[7:0], AD1		VBAT	
	VmaxPS	Pin PS		15	
	VmaxSENSE [2:1]	Pins SENSE[2:1]		VS+0.3	
	VmaxREL[2:1]	Pins REL[2:1]		Vcrel[2:1]	
Voltage on Analogue LV	VANA_LV	Pins RTG, TC[2:1], OSC[2:1] RTG (in case of external bipolar transistor)	-0.3	VDDA +0.3	

# Product Abstract

## MLX81150

### LIN-Slave for relay and DC motor control

Parameter	Symbol	Condition	Limit Min	Limit Max	Unit
				5	
Digital Output Voltage	VOUT_DIG	Pin TO	-0.3	VDDA +0.3	
Digital Input Voltage	VIN_DIG	Pins TI[2:1]	-0.3	VDDA +0.3	
Digital Input Current	IIN_DIG	Pins TI[2:1]	-10	10	mA
Maximum latch-up free current at any pin	ILATCH	according to JEDEC JESD78, AEC-Q100-004	-250	250	
ESD capability of pin LIN	ESDHBM_LIN	Human body model [4]	-6	+6	kV
ESD capability of pin LIN	ESDIEC_LIN	Acc. To IEC 61000-4-2 [5]	-6	+6	kV
ESD capability of any other pin, except LIN	ESDHBM	Human body model [4]	-2	+2	kV
ESD capability at any pin	ESDCDM	Charge Device Model [6]	-500	+500	V
Storage temperature	Tstg		-55	150	°C
Junction Temperature	TJ		-40	155	°C
Thermal resistance QFN32 [3]	Rth	in free air, air flow 0m/s	~ 32		K/W

Table 2: Absolute maximum ratings

- [1] ISO 7637 test pulses are applied to VS via a reverse polarity diode and >1μF blocking capacitor;
- [2] ISO 7637 test pulses are applied to LIN via a coupling capacitance of 1nF;
- [3] Simulated value for low conductance board (JEDEC).
- [4] Equivalent to discharging a 100pF capacitor through a 1.5kΩ resistor conform to AEC-Q100-002 or ESDA/JEDEC JDS-001.
- [5] Equivalent to discharging a 150pF capacitor through a 330Ω resistor.
- [6] ESD CDM Test confirm to AEC-Q100-011 or JEDEC22-C101.

# Product Abstract

## MLX81150

### LIN-Slave for relay and DC motor control

#### 4. Application Examples

The following sections show typical application examples <sup>[1]</sup>.

##### 4.1. Single DC-Motor Drive

In this sample application the IC can realize the driving of a DC motor via an external relay bridge. Speed, position sensing and anti trap or block detection are done by means of external Hall latches connected to a timer capture unit. The Hall sensors are switched off during standby mode via a switch-able battery voltage output. Additionally Relay contact monitoring can be done by checking the voltages over it.

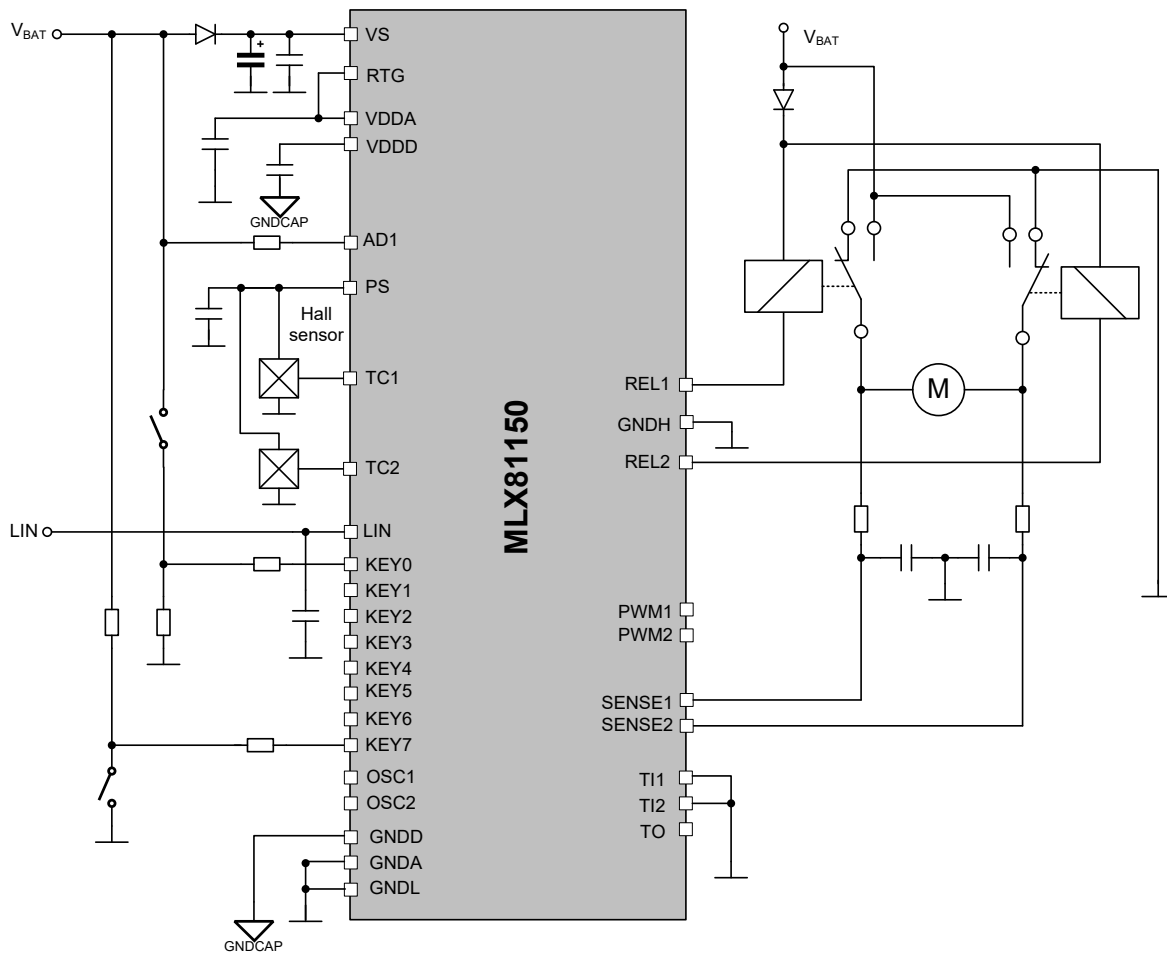

Figure 1- Principle application diagram showing a common relay driver controlled by external switches and LIN bus

# Product Abstract

## MLX81150

### LIN-Slave for relay and DC motor control

#### 4.2. Single DC Motor Drive with soft start / stop

For some applications it might be necessary:

- To control the motor speed especially during start / stop,
- To have an independent switching channel in case the relay “hangs”,
- To switch the power via the power transistor and to increase with this the life time of the relay contacts
- To monitor the motor current (current sensing and over current shut off).

This application requires then also a reverse polarity protection in the power path.

Following application diagram shows the practical realization in principle:

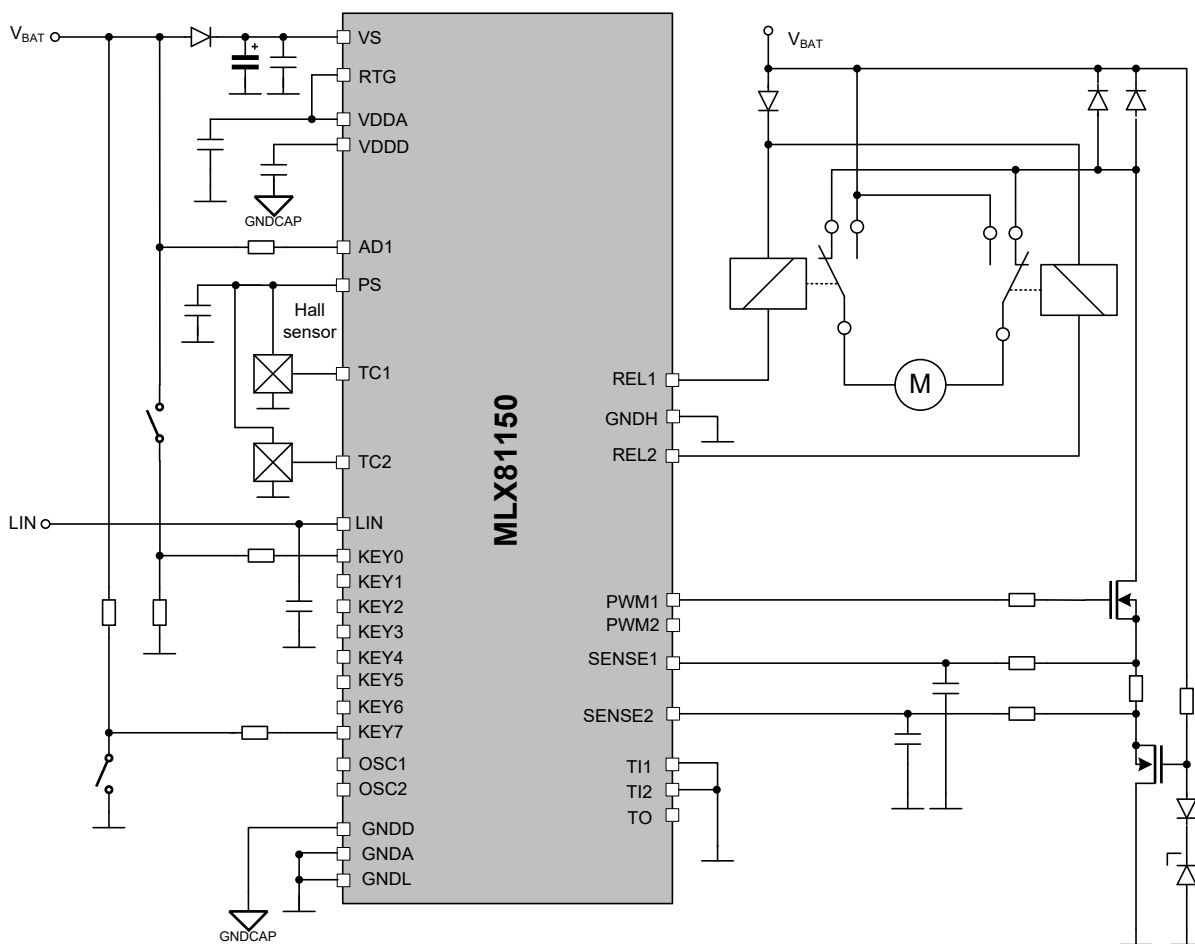

Figure 2- Principle application diagram showing a common relay driver controlled by external switches and LIN bus, with soft start / stop and motor current sense

# Product Abstract

## MLX81150

### LIN-Slave for relay and DC motor control

#### 4.3. Single DC motor drive in FET controlled full bridge applications

By adding some external additional circuitry, the IC will also allow to drive DC motors in full bridge applications. Position, speed and direction sensing is done via external Hall latches.

By having one PWM on the low side path of the half bridge and the inverse PWM (with programmable interlock delay in the high side path) the p channel can be actively switched on in case the current wheels out.

Same is for the n-channel Transistor.

The other side of the full bridge is then statically switched on or off.

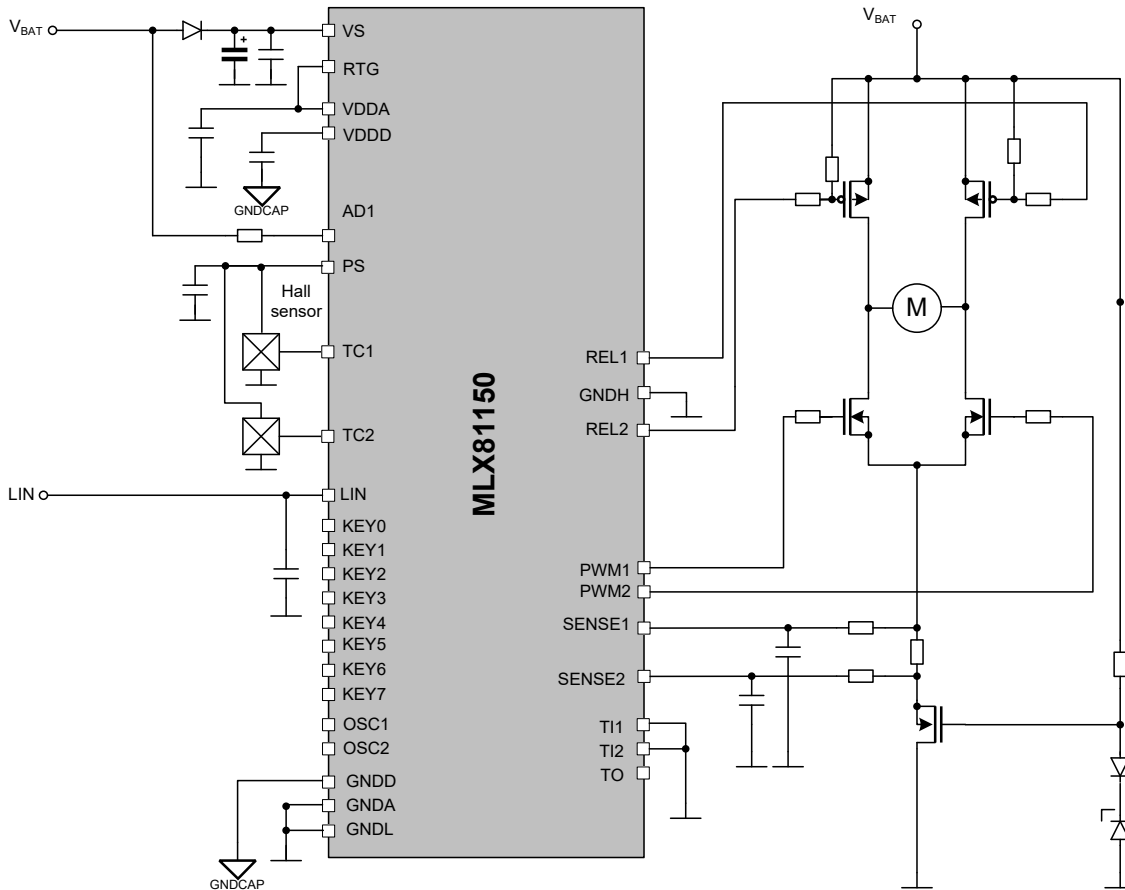

Figure 3- Single DC Motor drive; full bridge

# Product Abstract

## MLX81150

### LIN-Slave for relay and DC motor control

#### 4.4. LED-Lamp driver, switch mode power supply

In this application the MLX81150 drives a LED lamp with several high power LEDs in a DC-DC converter configuration. The module itself is controlled via the LIN bus. The current in the LED is regulated to a given value. Adjusting PWM frequency and PWM ratio allows controlling the transformer in a very efficient way from EMC perspective as well as from energy point of view.

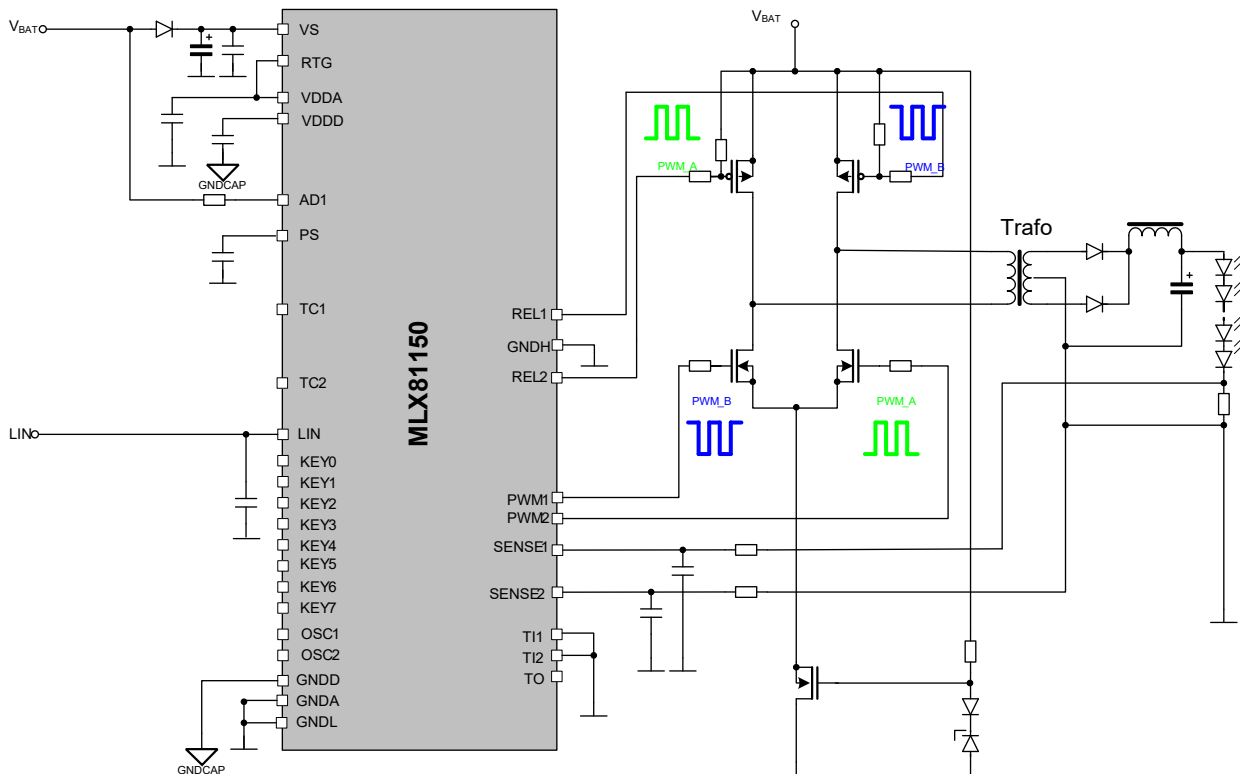

Figure 4- Principle application diagram showing a DC/DC converter for high power LED lamp driving controlled by a LIN bus

# Product Abstract

## MLX81150

### LIN-Slave for relay and DC motor control

#### 4.5. MLX81150 in 1- and 2- phase BLDC (brush less DC) Motor control applications

BLDC motors are used today in several permanent running automotive applications. 1- and 2-phase BLDC motors are applied in several auxiliary applications as small pumps and blowers. In case these pumps request a LIN or PWM interface connection, the MLX81150 is a perfect solution for that. The commutation information for the brush less DC motors is provided by a hall switch/latch reacting on positive and negative magnet field of the permanent magnet rotor.

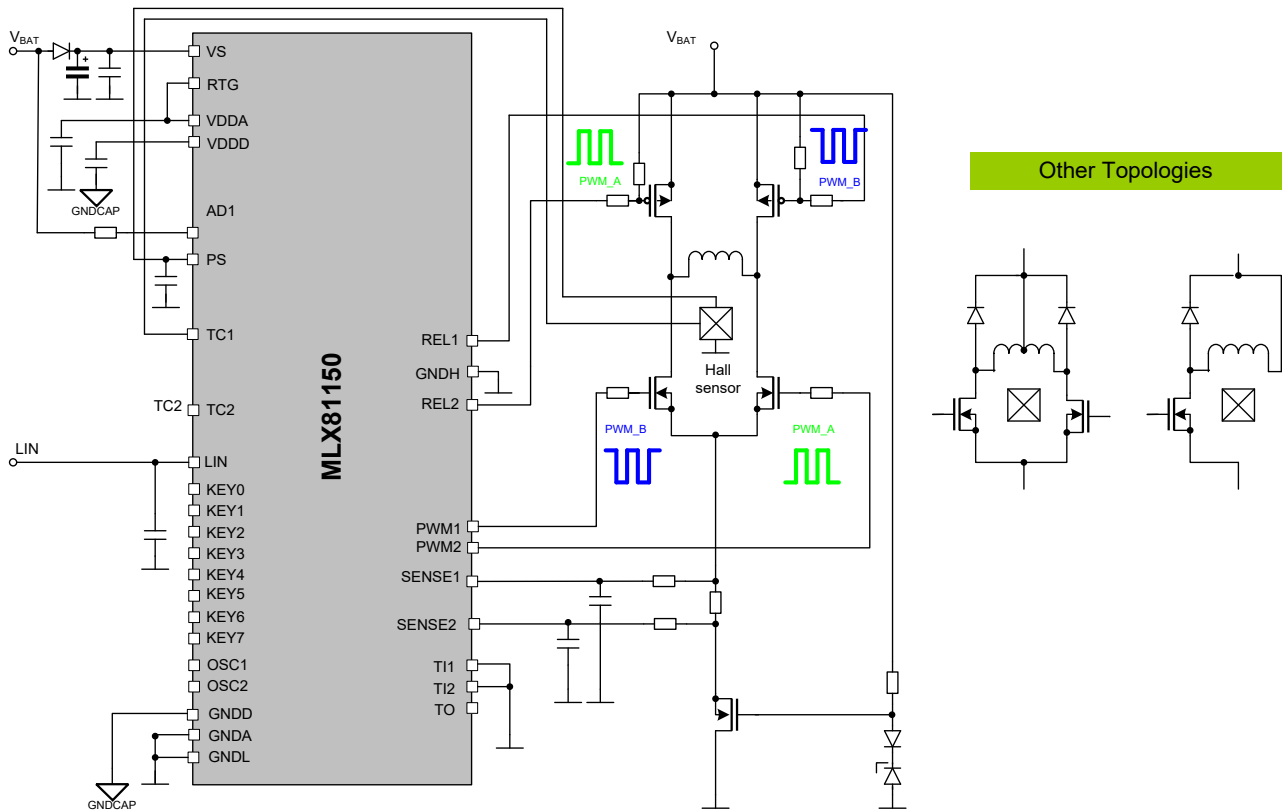

Figure 5- Principle application diagram showing a 1 / 2 phase BLDC motor drive

# Product Abstract

## MLX81150

### LIN-Slave for relay and DC motor control

#### 4.6. Key inputs with different wetting currents in active and sleep configuration

Depending on different application requests for the key inputs it might be necessary to use in active mode relatively high wetting currents for the external switches. These currents will be provided by external pull up / pull down resistors. The IC will read the switches then with suitable threshold levels.

In SLEEP MODE relatively low wetting currents are necessary. These currents will be provided by external pull up / pull down resistors. Wake up will be then just with a rising or falling edge of the incoming signal.

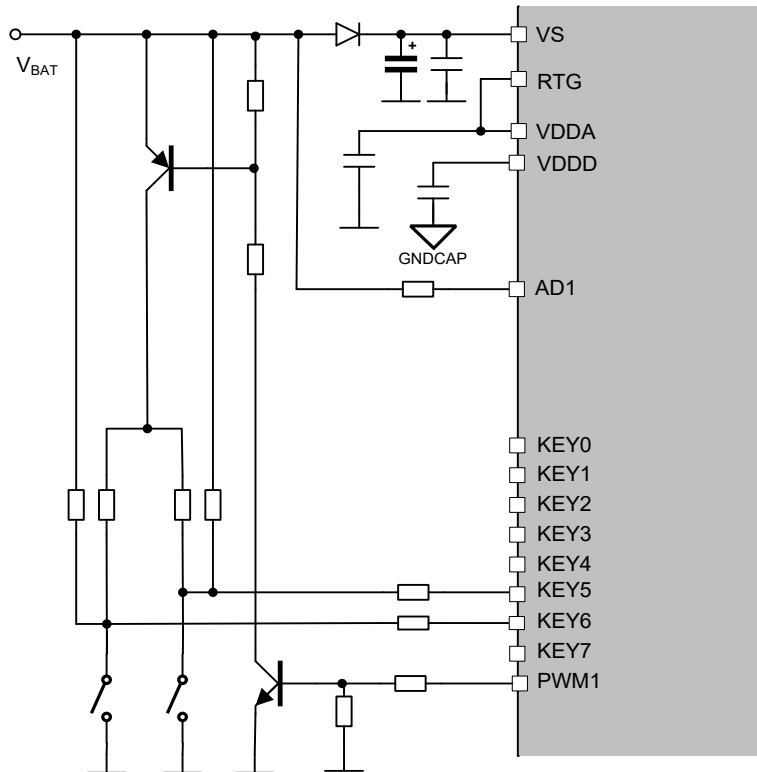

Figure 6 - Principle application diagram using different wetting currents in active and SLEEP MODE configuration, switches are related to GND; PWM1 pin provides steady state voltage level, pull up currents



# Product Abstract

## MLX81150

### LIN-Slave for relay and DC motor control

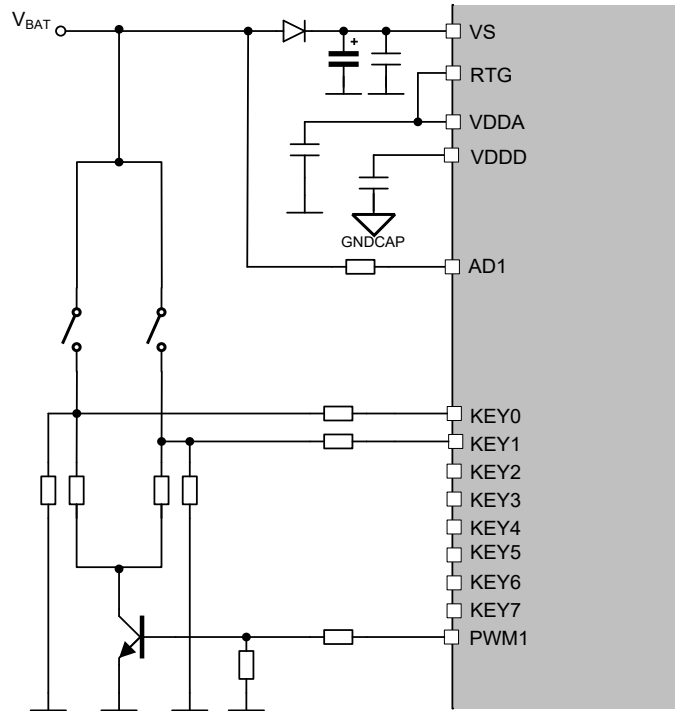

Figure 7 – Principle application diagram using different wetting currents in active and SLEEP MODE configuration, switches are related to supply; PWM1 pin just provides steady state voltage level, pull down currents

Via a 2-stage measurement, first at pin AD1 to check the VBAT and second at pin KEY7, it is possible to check also the status of so called ‘Matrix Switches’. Figure 8 shows the principle of this application.

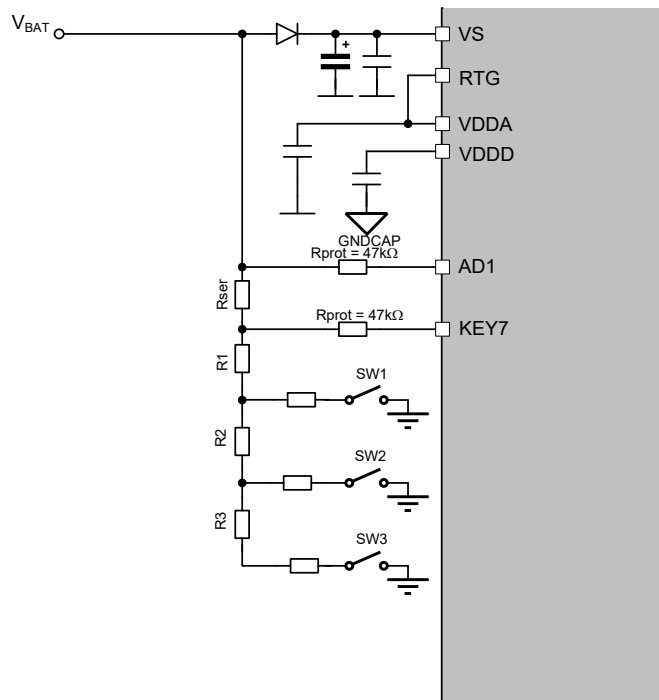

Figure 8 – Principle application diagram with matrix switch detection via KEY7 and AD1

# Product Abstract

## MLX81150

### LIN-Slave for relay and DC motor control

#### 5. Mechanical Specification - Package data QFN32

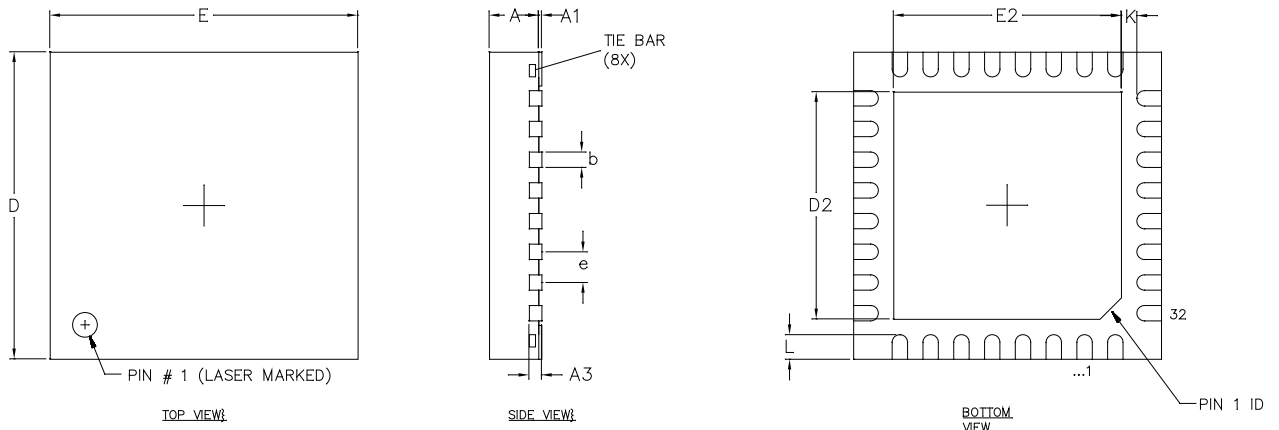

#### COMMON DIMENSIONS AND TOLERANCES

SYMBOL	ALL DIMENSION ARE IN MILLIMETERS		
	MINIMUM	NOMINAL	MAXIMUM
A	0.80	0.90	1.00
A1	0	0.02	0.05
A3	0.20 REF		
D	4.90	5.00	5.10
E	4.90	5.00	5.10
D2	3.60	3.70	3.80
E2	3.60	3.70	3.80
L	0.30	0.40	0.50
K	0.20	---	---
b	0.18	0.25	0.30
e	0.50 BSC		

#### NOTE :

1. EXPOSED TIE BAR SHOULD BE KEPT FREE FROM SOLDER.
2. SIDE WALL IMMERSION TIN PLATING MIN 1um THICK.

Figure 4: Package Drawing

# Product Abstract

**MLX81150**

**LIN-Slave for relay and DC motor control**

## 6. Marking/Order Code

### 6.1. Marking MLX81150

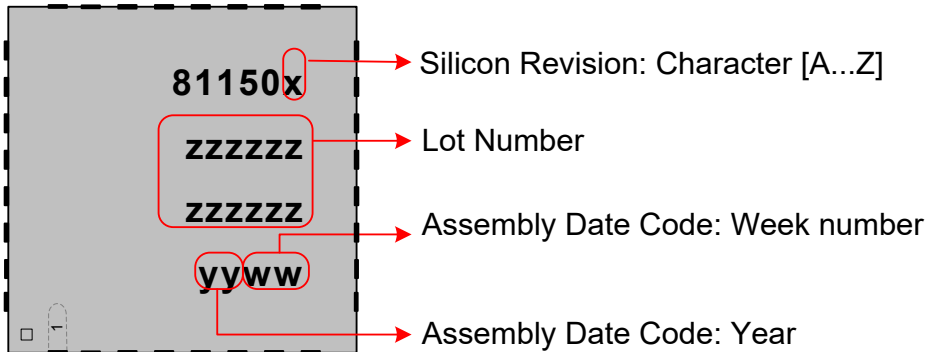

### 6.2. Order Code MLX81150

Order Code	Temp. Range	Package	Delivery	Remark
MLX81150 LLW-DAA-000-RE	-40 - 150 °C	QFN32 5x5	Reel	MLX81150D

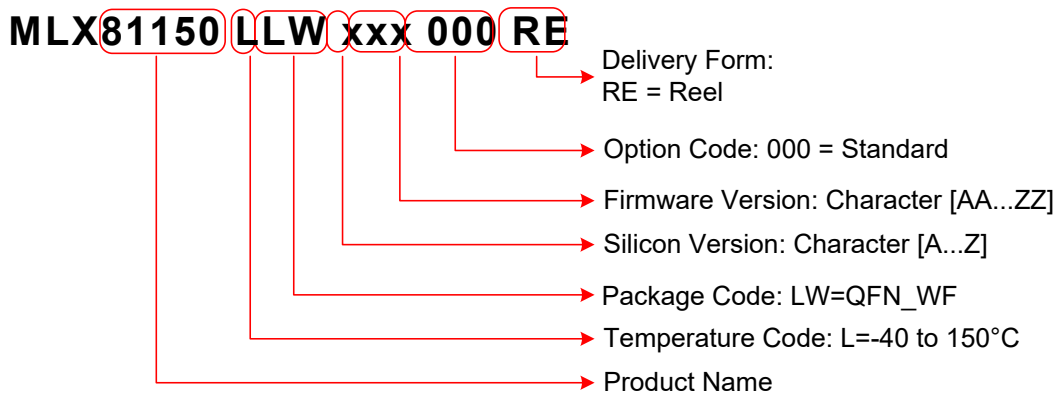

# Product Abstract

**MLX81150**

**LIN-Slave for relay and DC motor control**

## 7. Assembly Information

Our products are classified and qualified regarding soldering technology, solderability and moisture sensitivity level according to following test methods:

### Reflow Soldering SMD's (Surface Mount DeVICES)

- IPC/JEDEC J-STD-020  
Moisture/Reflow Sensitivity Classification for Nonhermetic Solid State Surface Mount Devices (classification reflow profiles according to table 5-2)
- EIA/JEDEC JESD22-A113  
Preconditioning of Nonhermetic Surface Mount Devices Prior to Reliability Testing (reflow profiles according to table 2)

### Wave Soldering SMD's (Surface Mount DeVICES) and THD's (Through Hole DeVICES)

- EN60749-20  
Resistance of plastic- encapsulated SMD's to combined effect of moisture and soldering heat
- EIA/JEDEC JESD22-B106 and EN60749-15  
Resistance to soldering temperature for through-hole mounted devices

### Iron Soldering THD's (Through Hole DeVICES)

- EN60749-15  
Resistance to soldering temperature for through-hole mounted devices

### Solderability SMD's (Surface Mount DeVICES) and THD's (Through Hole DeVICES)

- EIA/JEDEC JESD22-B102 and EN60749-21  
Solderability

For all soldering technologies deviating from above mentioned standard conditions (regarding peak temperature, temperature gradient, temperature profile etc) additional classification and qualification tests have to be agreed upon with Melexis.

The application of Wave Soldering for SMD's is allowed only after consulting Melexis regarding assurance of adhesive strength between device and board.

Melexis recommends reviewing on our web site the General Guidelines [soldering recommendation](http://www.melexis.com/Quality_soldering.aspx) ([http://www.melexis.com/Quality\\_soldering.aspx](http://www.melexis.com/Quality_soldering.aspx)) as well as [trim&form recommendations](http://www.melexis.com/Assets/Trim-and-form-recommendations-5565.aspx) (<http://www.melexis.com/Assets/Trim-and-form-recommendations-5565.aspx>).

Melexis is contributing to global environmental conservation by promoting **lead free** solutions. For more information on qualifications of **RoHS** compliant products (RoHS = European directive on the Restriction Of the use of certain Hazardous Substances) please visit the quality page on our website: <http://www.melexis.com/quality.aspx>

# Product Abstract

**MLX81150**

**LIN-Slave for relay and DC motor control**

## 8. Contact

For the latest version of this document, go to our website at [www.melexis.com](http://www.melexis.com).

For additional information, please contact our Direct Sales team and get help for your specific needs:

Europe, Africa	Telephone: +32 13 67 04 95
	Email : sales_europe@melexis.com
Americas	Telephone: +1 603 223 2362
	Email : sales_usa@melexis.com
Asia	Email : sales_asia@melexis.com

## 9. Disclaimer

*The content of this document is believed to be correct and accurate. However, the content of this document is furnished "as is" for informational use only and no representation, nor warranty is provided by Melexis about its accuracy, nor about the results of its implementation. Melexis assumes no responsibility or liability for any errors or inaccuracies that may appear in this document. Customer will follow the practices contained in this document under its sole responsibility. This documentation is in fact provided without warranty, term, or condition of any kind, either implied or expressed, including but not limited to warranties of merchantability, satisfactory quality, non-infringement, and fitness for purpose. Melexis, its employees and agents and its affiliates' and their employees and agents will not be responsible for any loss, however arising, from the use of, or reliance on this document. Notwithstanding the foregoing, contractual obligations expressly undertaken in writing by Melexis prevail over this disclaimer.*

*This document is subject to change without notice, and should not be construed as a commitment by Melexis. Therefore, before placing orders or prior to designing the product into a system, users or any third party should obtain the latest version of the relevant information.*

*Users or any third party must determine the suitability of the product described in this document for its application, including the level of reliability required and determine whether it is fit for a particular purpose.*

*This document as well as the product here described may be subject to export control regulations. Be aware that export might require a prior authorization from competent authorities. The product is not designed, authorized or warranted to be suitable in applications requiring extended temperature range and/or unusual environmental requirements. High reliability applications, such as medical life-support or life-sustaining equipment or avionics application are specifically excluded by Melexis. The product may not be used for the following applications subject to export control regulations: the development, production, processing, operation, maintenance, storage, recognition or proliferation of:*

- 1. chemical, biological or nuclear weapons, or for the development, production, maintenance or storage of missiles for such weapons;*
- 2. civil firearms, including spare parts or ammunition for such arms;*
- 3. defense related products, or other material for military use or for law enforcement;*
- 4. any applications that, alone or in combination with other goods, substances or organisms could cause serious harm to persons or goods and that can be used as a means of violence in an armed conflict or any similar violent situation.*

*No license nor any other right or interest is granted to any of Melexis' or third party's intellectual property rights.*

*If this document is marked "restricted" or with similar words, or if in any case the content of this document is to be reasonably understood as being confidential, the recipient of this document shall not communicate, nor disclose to any third party, any part of the document without Melexis' express written consent. The recipient shall take all necessary measures to apply and preserve the confidential character of the document. In particular, the recipient shall (i) hold document in confidence with at least the same degree of care by which it maintains the confidentiality of its own proprietary and confidential information, but no less than reasonable care; (ii) restrict the disclosure of the document solely to its employees for the purpose for which this document was received, on a strictly need to know basis and providing that such persons to whom the document is disclosed are bound by confidentiality terms substantially similar to those in this disclaimer; (iii) use the document only in connection with the purpose for which this document was received, and reproduce document only to the extent necessary for such purposes; (iv) not use the document for commercial purposes or to the detriment of Melexis or its customers. The confidentiality obligations set forth in this disclaimer will have indefinite duration and in any case they will be effective for no less than 10 years from the receipt of this document.*

*This disclaimer will be governed by and construed in accordance with Belgian law and any disputes relating to this disclaimer will be subject to the exclusive jurisdiction of the courts of Brussels, Belgium.*

*The invalidity or ineffectiveness of any of the provisions of this disclaimer does not affect the validity or effectiveness of the other provisions. The previous versions of this document are repealed.*

*Melexis © - No part of this document may be reproduced without the prior written consent of Melexis. (2020)*

*IATF 16949 and ISO 14001 Certified*