

T1/E1/CEPT/ISDN-PRI SMT TRANSFORMERS

Ruggedized



- ⊗ Pick and Place Compatible
- ⊗ Isolation Voltage: 1500 Vrms minimum Extended
- ⊗ Temperature Range: -55°C to +125°C
- ⊗ Lead Finish: Sn63/Pb37
- ⊗ Epoxy Encapsulated
- ⊗ Moisture Sensitivity Level: 3

Electrical Specifications @ 25°C — Operating Temperature -55°C to +125°C

Part Number	Turns Ratio (Pri:Sec ±2%)	OCL Pri @ 25°C (mH MIN)	C _{ww} (pF MAX)	DCR Pri (Ω MAX)	Primary Pins
PL1374	1CT: 1CT	1.2	35	0.8	1-3

Note: 1. Add suffix "NL" for RoHS compliant part; i.e. PL1374 becomes **PL1374NL**.

2. Optional Tape & Reel packaging can be ordered by adding a "T" suffix to the part number (i.e. PL1374 becomes **PL1374T**).

Mechanical

Electrical Schematic

PL1374

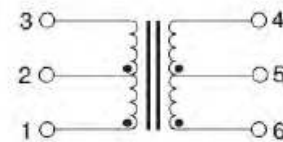
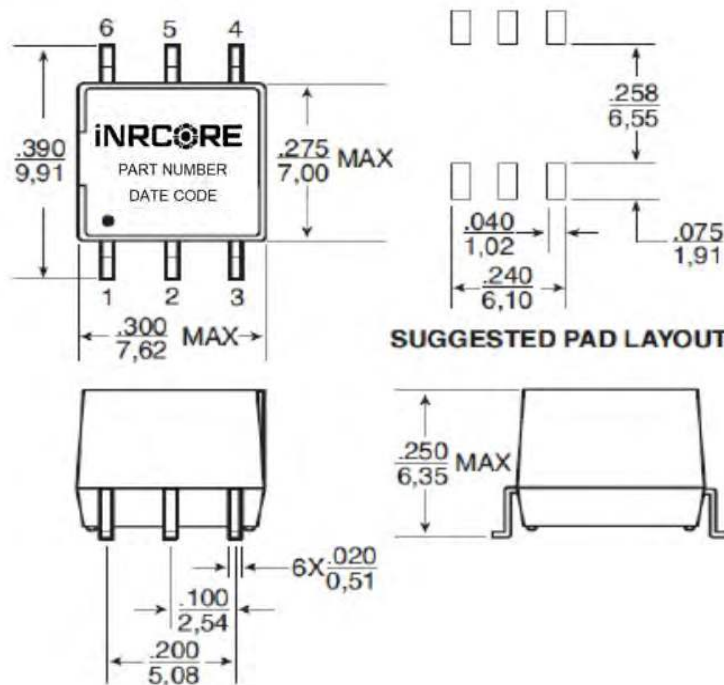

Dimensions: $\frac{\text{Inches}}{\text{mm}}$

Unless otherwise specified, all tolerances are: $\pm \frac{.010}{0,25}$



Tin/Lead Recommended Reflow Profile (Based on J-STD-020D)

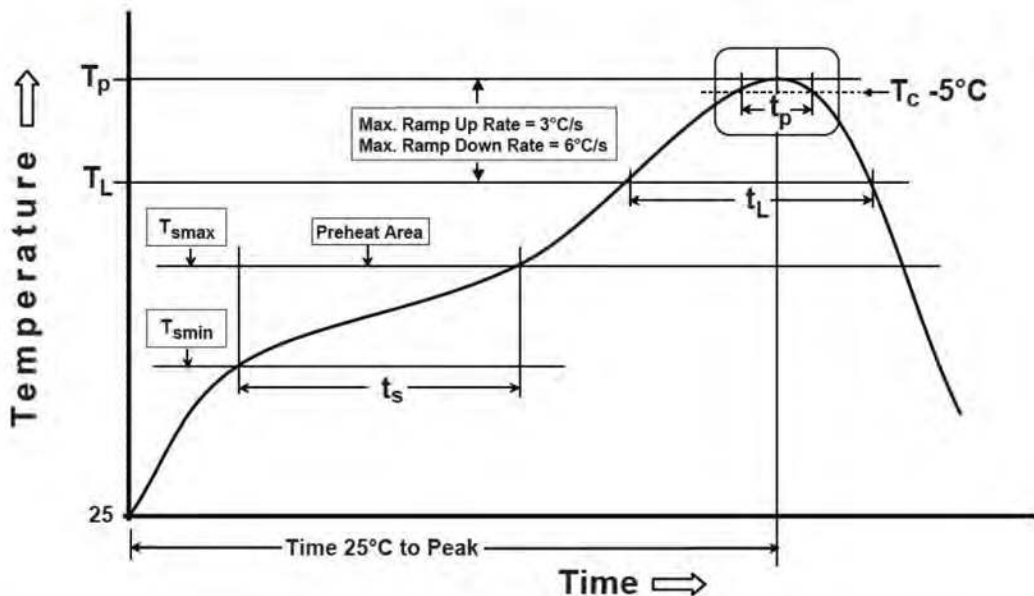

T_{SMIN} (°C)	T_{SMAX} (°C)	T_L (°C)	T_P (°C MAX)	t_s (s)	t_L (s)	t_p (s MAX)	Ramp-up rate (T_L to T_P)	Ramp-down rate (T_P to T_L)	Time 25°C to peak temperature (s MAX)
100	150	183	235	60-120	60-150	20	3°C/s MAX	6°C/s MAX	360

Notes:

1. All temperatures measured on the package leads.
2. Maximum times of reflow cycle: 2.

For More Information

iNRCORE, LLC
311 Sinclair Road Bristol,
PA 19007-6812 U.S.A
Tel: + 1.215.781.6400
Fax: +1.215.7816430

Global Sales Representatives and Locations:
<http://www.inrcore.com>

Performance warranty of products offered on this data sheet is limited to the parameters specified. Data is subject to change without notice. Other brand and product names mentioned herein may be trademarks or registered trademarks of their respective owners. © Copyright, 2020. iNRCORE, LLC. All rights reserved.

