



2 Channel SSR Breakout Board User Guide

Get in touch with us!

Please feel free to send a mail to one of the mail IDs below or use the Contact Us page at <http://www.numato.com> to drop us a quick message.

Technical Help

Got technical questions? Please write to help@numato.com

Sales Team

Questions about making payments, volume discounts, academic/open source discounts, purchase orders and quotes? Please write to sales@numato.com

Webmaster

Questions/Suggestions about our website? Please write to webmaster@numato.com



Like us on Facebook! <https://www.facebook.com/numato>

Visit our blog <http://www.numato.cc> for news, updates and specials.

Mailing Address

Numato Systems Pvt Ltd
1st Floor, #56C Wipro Avenue
Phase 1 - Electronic City
Bangalore, KA-560100, India

* Mail orders, phone orders and direct pick up are not available at this time. Please visit our online store to place your order. Estimated shipping time to your address will be displayed in the shopping cart before checkout.



SOME RIGHTS RESERVED

You may use, modify or share this publication or part of thereof adhering to Creative Commons Attribution-ShareAlike 3.0 Unported (CC BY-SA 3.0) License.

See complete license text at <http://creativecommons.org/licenses/by-sa/3.0/>

All trademarks are property of their respective owners.

Introduction

Numato Lab's 2 Channel Solid State Relay Breakout Board is a smart choice for controlling higher current loads from your micro controller development board or a PC parallel port. This board has two on-board relays which can switch up to 3A AC or DC load depending up on the relay type. The IN and OUT terminal of the relays are accessible through screw terminals which makes wiring up the board very easy. The relays are driven by popular darlington array ULN2003.

Some of the possible uses of this module include

- Home Automation
- Lighting Control
- Garden Equipment Control
- Industrial Automation
- Test Fixtures
- DIY and Hobby

This module has two on board Solid State Relays and associated drivers capable of controlling a large number of devices including lamps, motors, locks etc...

Features

- Very compact and easy to wire up
- Connects directly to TTL devices (Microcontrollers, Arduino etc..)
- Two Solid State Relays with two pin screw terminals for easy connectivity
- LED indication for Power and individual relay status
- Fuses are provided for over current protection for each relay

How to use the module

The following section describes how to use this module.

Components/Tools required

Along with the module, you may need the items in the list below for easy and fast installation.

1. 5-12V DC power supply
2. Medium size screw driver

Connection Details



IMPORTANT Please exercise utmost caution while working with electrical mains or other high voltages. Failure to comply with safety regulations may result in injury and or death. Solid State Relays are rated for either AC or DC load, not both at the same time. Trying to connect incorrect load/power type can cause permanent failure to this product or any attached devices and could cause other losses or injuries.

Connection Diagram

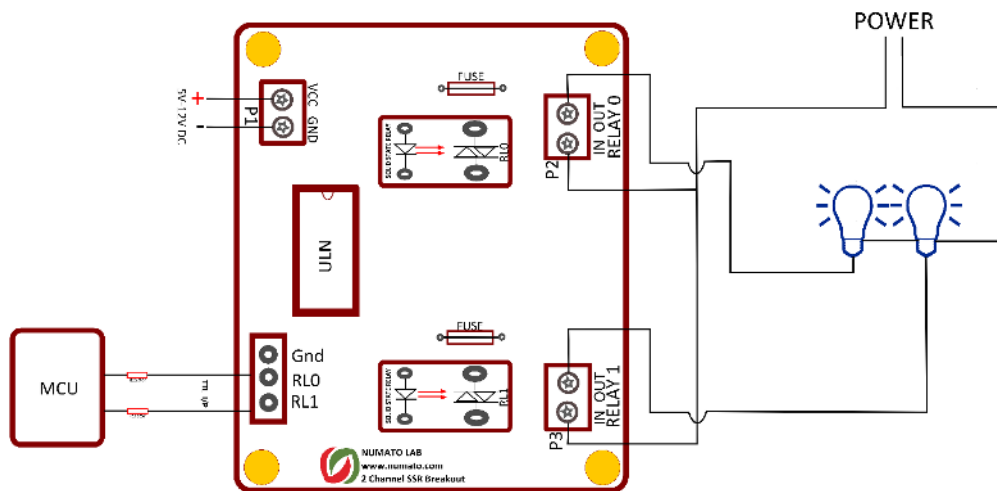

Above image shows basic connection diagram that can be used in most of the situations. The connection diagram showed above is for AC load. Please make sure to use a freewheeling diode or snubber circuit if the load is inductive.

More details about using inductive loads is available elsewhere in this document. It is important to make sure that the wires used to connect loads are sufficiently rated to handle expected load current. Exercise caution while working with high voltages. The following sections identify individual connections in detail.

Relay Contacts

This module has two Solid State Relay that can switch up to 3A current. All contacts on each relay is available externally on screw terminals for easy user access. The relays are rated for either AC or DC switching supply voltages. Please see the electrical parameter table for more details. Each relay has two contacts (**IN/-** and **OUT/+**). For AC Relay the contact will be established between **IN** and **OUT** contacts when the relay is turned on and will be disconnected when relay is turned off. For DC relay connect **+** to **OUT** and **-** to **IN**. Table below summarizes possible relay contact positions.



Relay State	Connection between IN/- and OUT/+
OFF	Open
ON	Close

DC Power Supply

This module requires 5V -12 V DC input for operation. Make sure to connect the power supply in correct polarity. Connect the **positive** terminal of the power supply to the **VCC** terminal on the module. Connect **negative** terminal of the power supply to **GND** terminal of the module. Connecting power supply incorrectly can cause damage to the module and/or other devices.

Triggering Relay

The relays on the board can be either turned on by supplying positive TTL compatible input. This can be achieved by using micro controller or 5V DC power supply with a series 2.2K ohm resistor. The triggering pins are marked as RL0 to RL1 respectively.

Trigger In	Relay
RL0	Relay 0
RL1	Relay 1

Additional Information

Using relay modules with inductive loads

It is important to take additional care when using relays with inductive loads. An inductive load is pretty much anything that has a coil and works based on magnetic principles like Motors, Solenoids and transformers. Inductive loads produce back emf when the magnitude of the load current changes. The back emf can be in the order of tens or even hundreds of voltage (See this Wikipedia article http://en.wikipedia.org/wiki/Counter-electromotive_force). This effect is most severe when power is disconnected from inductive load because the rate of change of current is maximum at that point. Even though the back emf lives only for a very short time (a few milliseconds) it can cause sparks between the relay contacts and can deteriorate the contact quality over time and reduce the life span for the relays considerably.

So it is important to take countermeasures to suppress the back emf to acceptable levels to protect relay contacts. Usually this requires connecting electronic devices in parallel with the load such that they absorb the high voltage components generated by the load. For solenoids, connecting a diode (fast switching diode is recommended) in parallel to the load (in reverse direction to the load current) is very effective. A diode used for this purpose is usually called a freewheeling diode. Please see the diagram on the right for connection details.

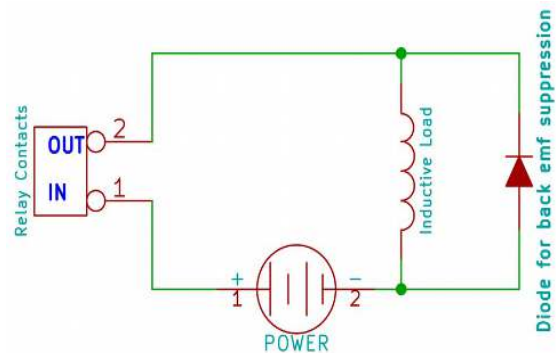

A capacitor with proper rating is recommended for protecting the relay contacts when a motor is used as load. The capacitor should be rated enough to withstand the back emf that is generated by the motor. Please see the diagram below for connection details.

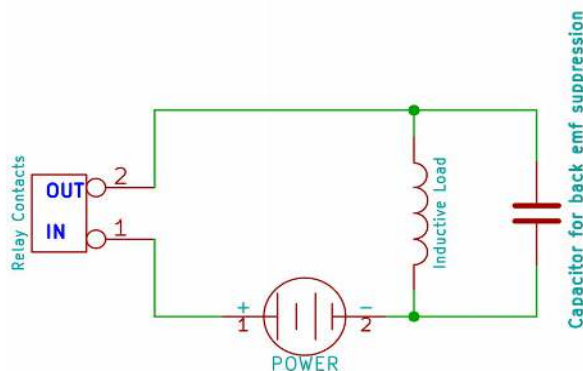

Please note that the relay modules are **NOT** shipped with back emf suppression devices pre-installed. The exact kind of suppression device and the parameters of the selected device can vary depending on the load itself. Some of the parameters that affects the suppression device selection are the inductance of the load, power supply voltage, load current, physical size/structure of the load etc.. It is obvious that it is impossible for us to predict these parameters and design required back emf suppression device and incorporate that on the board. So we believe this is a task best left to the module user. There is an excellent article on designing back emf suppression on Wikipedia at http://en.wikipedia.org/wiki/Flyback_diode

Technical Specifications

Parameter *	Value	Unit
Basic Specifications		
Number of relays	2	
Relay Specifications		
Input signal voltage rating	5 – 12	V
Input current rating	5 – 12	mA
Operating frequency	47 – 70	Hz
Operating temperature	-30 – 100	°C
Storage Temperature	-30 – 125	°C
Maximum switching voltage	250VAC/100VDC ¹	V
Maximum switching current	3	A
Isolation Resistance	10	GΩ
Isolation voltage input to output	4000	Vrms
Maximum switching on response time	8.3/5 (AC/DC) ¹	mS
Maximum switching off response time	8.3/2 (AC/DC) ¹	mS

* All parameters considered nominal. Numato Systems Pvt Ltd reserve the right to modify products without notice.

* AC Relay Datasheet <http://www.cosmo-ic.com/object/products/KSD203AC2.pdf>

* DC Relay Datasheet <http://www.cosmo-ic.com/object/products/KSD203DC2.pdf>

1. AC and DC models available. Product does not support both AC and DC at the same time.

FAQ

Q. I need a customized version of this product, can Numato do the customization for me?

A. Yes, we can definitely do customization but there may be minimum order requirements depending on the level of customization required. Please write to sales@numato.com for a quote.

Q. Where can I buy this product?

A. All Numato products can be ordered directly from our web store <http://www.numato.com>. We accept major credit cards and Paypal and ship to almost all countries with a few exceptions. We do have distributors in many countries where you can place your order. Please find the current list of distributors at <http://numato.com/distrib>.

Physical Dimensions

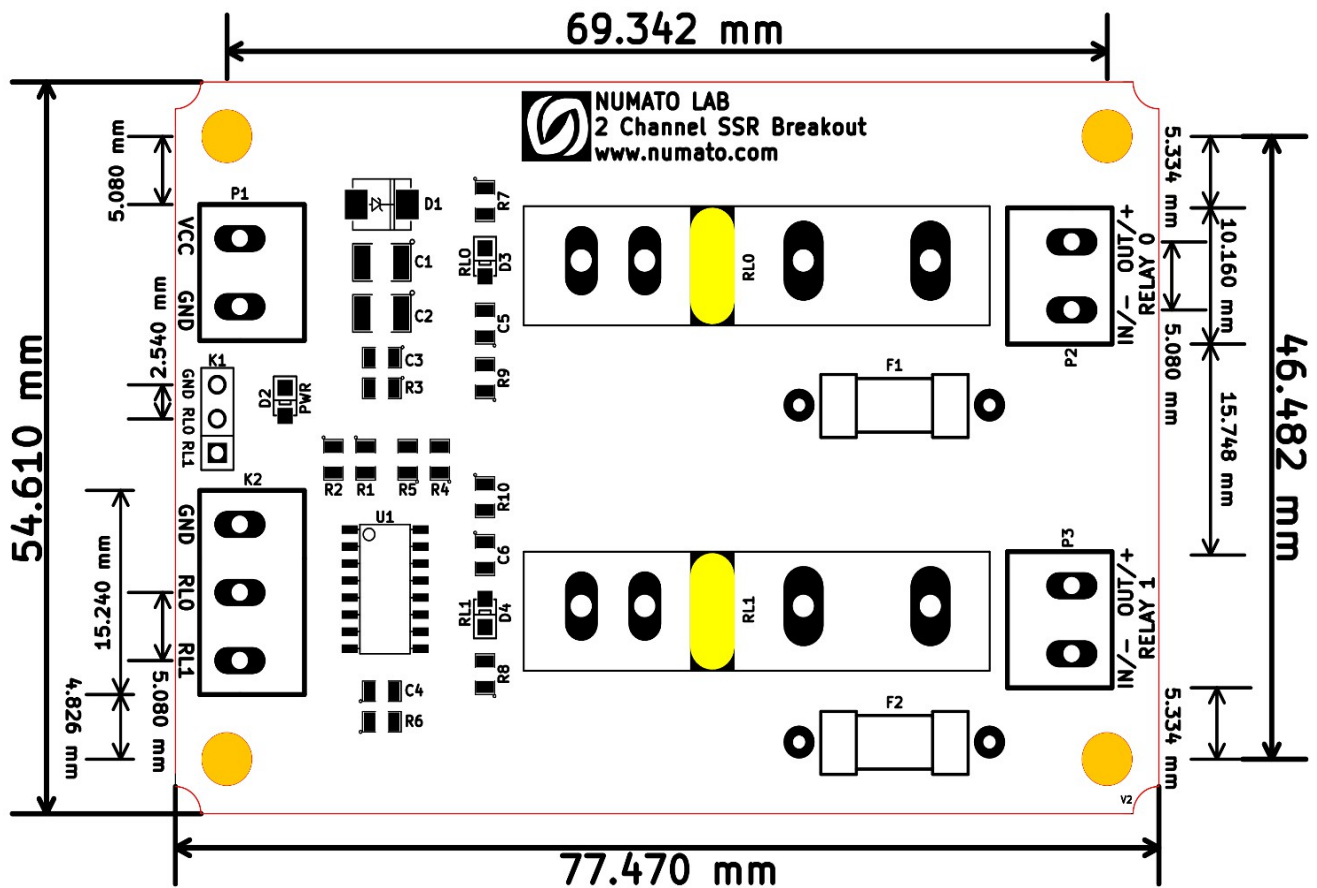

L x W x H : 77.470 mm x 54.610 mm x 30 mm

Mechanical Hole Diameter- 4.0 mm

Schematics

See next page.

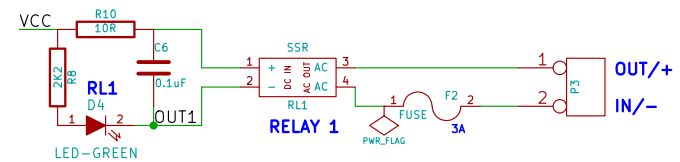
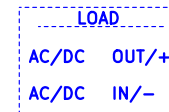
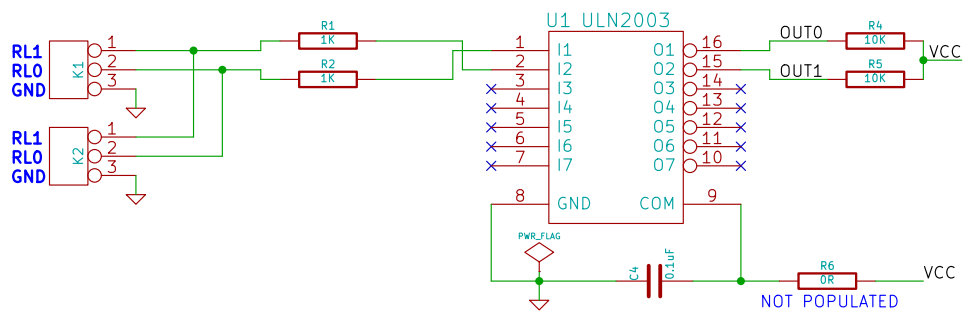
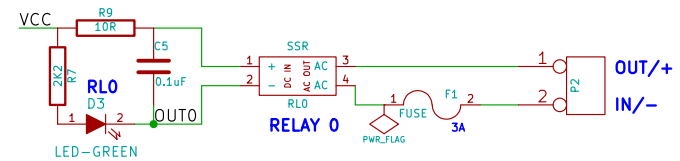
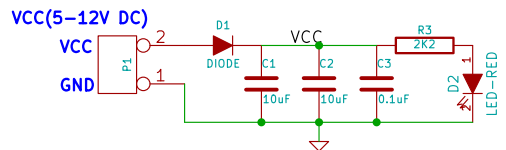

License : CC BY-SA		
http://www.numato.com		
Numato Labs		
File: 2ChannelSSRBreakout.sch		
Sheet: /		
Title: 2 Channel Solid State Relay Breakout		
Size: A4	Date: 8 dec 2014	Rev: Rev1
KiCad E.D.A.		Id: 1/1