

TPS62125 Buck Converter Evaluation Module User's Guide



ABSTRACT

This user's guide describes the characteristics, operation, and use of the Texas Instruments TPS62125EVM-044 evaluation module (EVM). The EVM converts a 4-V to 17-V input voltage to a regulated 3.3-V output voltage that delivers 300 mA. The TPS62125 is a high efficiency and small solution for general purpose low power applications, such as those powered from multi-cell lithium, alkaline, or nickel batteries as well as energy harvesting.

Note

In July 2019, this EVM was updated in order to replace the TDK inductor which had been obsoleted. To accommodate a different inductor footprint, the printed circuit board (PCB) was updated to revision B. This entire user's guide was updated to reference the revision B PCB. The revision A schematic, bill of materials, and PCB layout are located at the end of this user's guide.

Table of Contents

1 Introduction	3
1.1 Background.....	3
1.2 Performance Specification.....	3
1.3 Modifications.....	3
2 Setup	5
2.1 Input/Output Connector Descriptions.....	5
2.2 Setup.....	5
3 TPS62125EVM-044 Test Results	6
4 Board Layout	7
5 TPS62125EVM-044 Photos	10
6 Schematic and Bill of Materials	12
6.1 Schematic.....	12
6.2 Bill of Materials.....	12
7 Revision A files	13
7.1 Board Layout.....	13
7.2 Schematic and Bill of Materials.....	15
8 Revision History	16

List of Figures

Figure 1-1. Loop Response Measurement Modification.....	4
Figure 3-1. Loop Response With $V_{IN} = 12\text{ V}$ and $I_{OUT} = 300\text{ mA}$	6
Figure 3-2. Thermal Performance With $V_{IN} = 12\text{ V}$ and $I_{OUT} = 300\text{ mA}$	6
Figure 4-1. Revision B Top Assembly Layer.....	7
Figure 4-2. Revision B Top Layer.....	8
Figure 4-3. Revision B Bottom Layer.....	9
Figure 6-1. Revision B TPS62125EVM-044 Schematic.....	12
Figure 7-1. Revision A Top Silk Layer.....	13
Figure 7-2. Revision A Top Layer.....	13
Figure 7-3. Revision A Bottom Layer.....	14
Figure 7-4. Revision A Top Assembly Layer.....	14
Figure 7-5. Revision A TPS62125EVM-044 Schematic.....	15

List of Tables

Table 1-1. Performance Specification Summary.....	3
Table 6-1. Revision B TPS62125EVM-044 Bill of Materials.....	12
Table 7-1. Revision A TPS62125EVM-044 Bill of Materials.....	15

Trademarks

All trademarks are the property of their respective owners.

1 Introduction

The TPS62125 is a 300-mA, synchronous, step-down converter in a 2x2-mm, 8-pin WSON package.

1.1 Background

The TPS62125EVM-044 (PWR044) uses the TPS62125 device and is set to a 3.3-V output. The EVM operates with full-rated performance with an input voltage between 4V and 17 V, assuming JP1 is connected between ON and EN.

The TPS62125 device contains an adjustable enable threshold and adjustable hysteresis feature. Thus, the input voltage at which the device enables and disables is fully programmable by the user. In the TPS62125EVM-044, the device is set to turn on at 6 V and turn off at 4 V. This feature can be bypassed by using jumper JP1, which overrides the programmed threshold voltages.

1.2 Performance Specification

[Table 1-1](#) provides a summary of the TPS62125EVM-044 performance specifications.

Table 1-1. Performance Specification Summary

Specification	Test Conditions	Min	Typ	Max	Unit
Input voltage	JP1 connected between EN and ON	4		17	V
Output voltage setpoint			3.3		V
Output current		0		300	mA

1.3 Modifications

The PCB for this EVM accommodates additional input and output capacitors, as well as a feedforward capacitor. The loop response can be measured.

1.3.1 Input and Output Capacitors

C4 is provided for an additional input capacitor. This capacitor is not required for proper operation but can be used to reduce the input voltage ripple.

C5, C6, and C7 are provided for additional output capacitors. These capacitors are not required for proper operation but can be used to reduce the output voltage ripple and to improve the load transient response. The total output capacitance must remain within the recommended range in the data sheet for proper operation.

1.3.2 Feedforward Capacitor

C8 is provided for a feedforward capacitor. This capacitor is not required for proper operation but can be used to improve the transient response. Typically, using a 22-pF feedforward capacitor reduces or eliminates any output voltage overshoot that may occur at start-up. C8 is located on the back side of the PCB.

1.3.3 Loop Response Measurement

The loop response of the EVM can be measured with two simple changes to the circuitry. First, cut the trace between the VOS pin and the inductor on the top layer. This change is shown in [Figure 1-1](#). Second, install a 10-Ω resistor across the resistor pads on the back of the PCB at R7. The pads are spaced to allow installation of an 0603-sized resistor. With these changes, an ac signal (10-mV, peak-to-peak amplitude recommended) can be injected into the control loop across the added resistor. Details of measuring the control loop of DCS-Control devices are found in [How to Measure the Control Loop of DCS-Control™ Devices](#). [Figure 3-1](#) shows the results of this test.

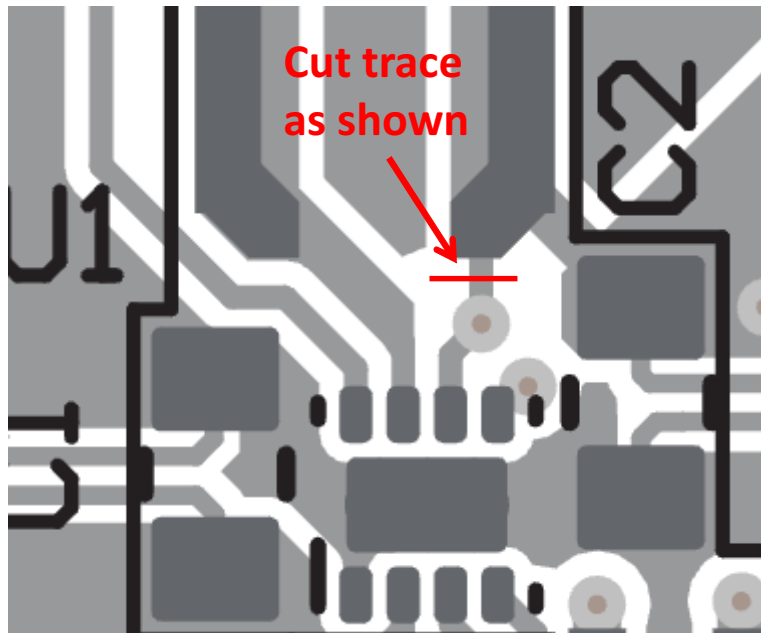

Figure 1-1. Loop Response Measurement Modification

2 Setup

This section describes how to properly use the TPS62125EVM-044.

2.1 Input/Output Connector Descriptions

J1, Pin 1 and 2 – VIN	Positive input connection from the input supply for the EVM.
J1, Pin 3 and 4 – S+/S-	Input voltage sense connections. Measure the input voltage at this point.
J1, Pin 5 and 6 – GND	Input return connection from the input supply for the EVM.
J2, Pin 1 and 2 – VOUT	Output voltage connection.
J2, Pin 3 and 4 – S+/S-	Output voltage sense connections. Measure the output voltage at this point.
J2, Pin 5 and 6 – GND	Output return connection.
J3 – PG/GND	The PG output appears on pin 1 of this header with a convenient ground on pin 2.
JP1 – EN	EN pin input jumper. Place the supplied jumper across ON and EN to turn on the IC. Place the jumper across OFF and EN to turn off the IC. Do not install the supplied jumper to utilize the adjustable enable threshold voltage feature of the IC.
JP2 – PG Pullup Voltage	PG pin pullup voltage jumper. Place the supplied jumper on JP2 to connect the PG pin pullup resistor to Vout. Alternatively, the jumper can be removed and a different voltage can be supplied on pin 1 to pull up the PG pin to a different level. This externally applied voltage must remain below 12 V.

2.2 Setup

To operate the EVM, set jumpers JP1 and JP2 to the desired positions per [Section 2.1](#). Connect the input supply to J1 and connect the load to J2.

3 TPS62125EVM-044 Test Results

This section provides test results of the TPS62125EVM-044. The TPS62125EVM-044 was used to take all the data in [TPS62125 3-V to 17-V, 300-mA Step-Down Converter With Adjustable Enable Threshold and Hysteresis](#). See the device data sheet for the performance of this EVM.

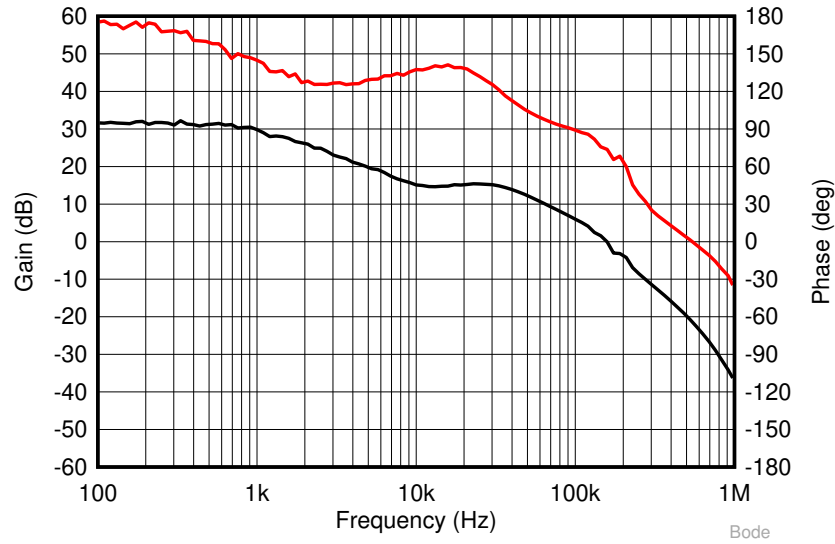

Figure 3-1. Loop Response With $V_{IN} = 12\text{ V}$ and $I_{OUT} = 300\text{ mA}$

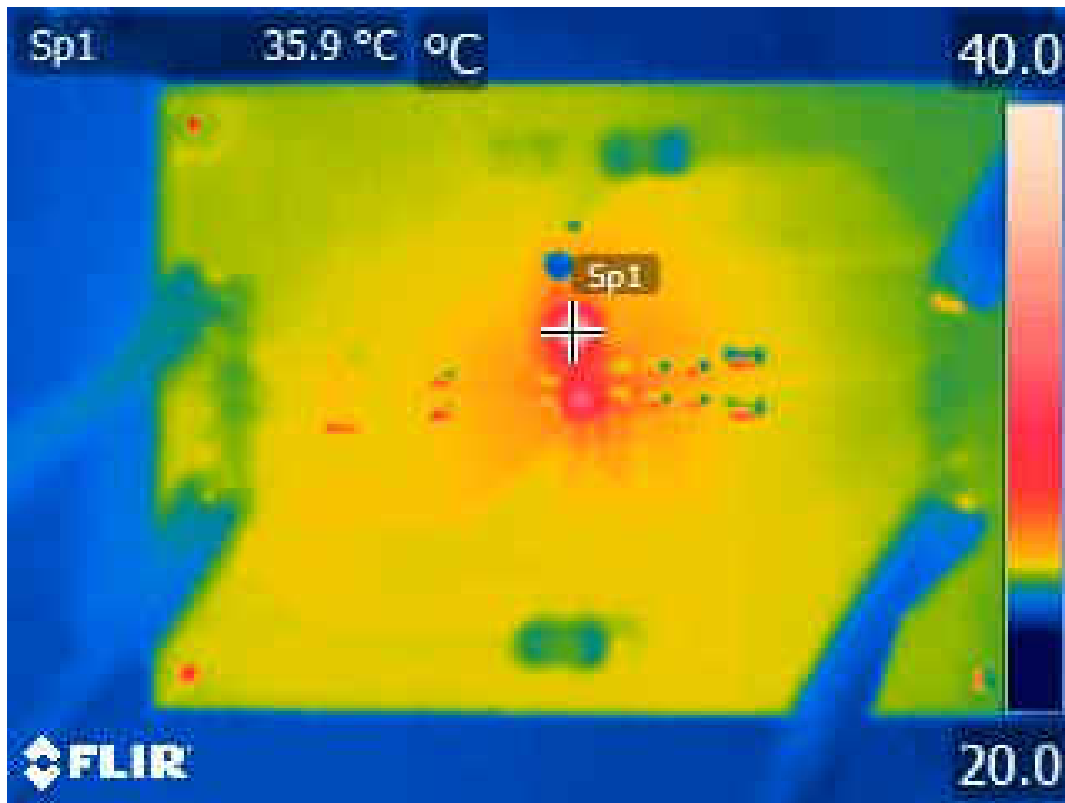

Figure 3-2. Thermal Performance With $V_{IN} = 12\text{ V}$ and $I_{OUT} = 300\text{ mA}$

4 Board Layout

This section provides the TPS62125EVM-044 revision B board layout and illustrations.

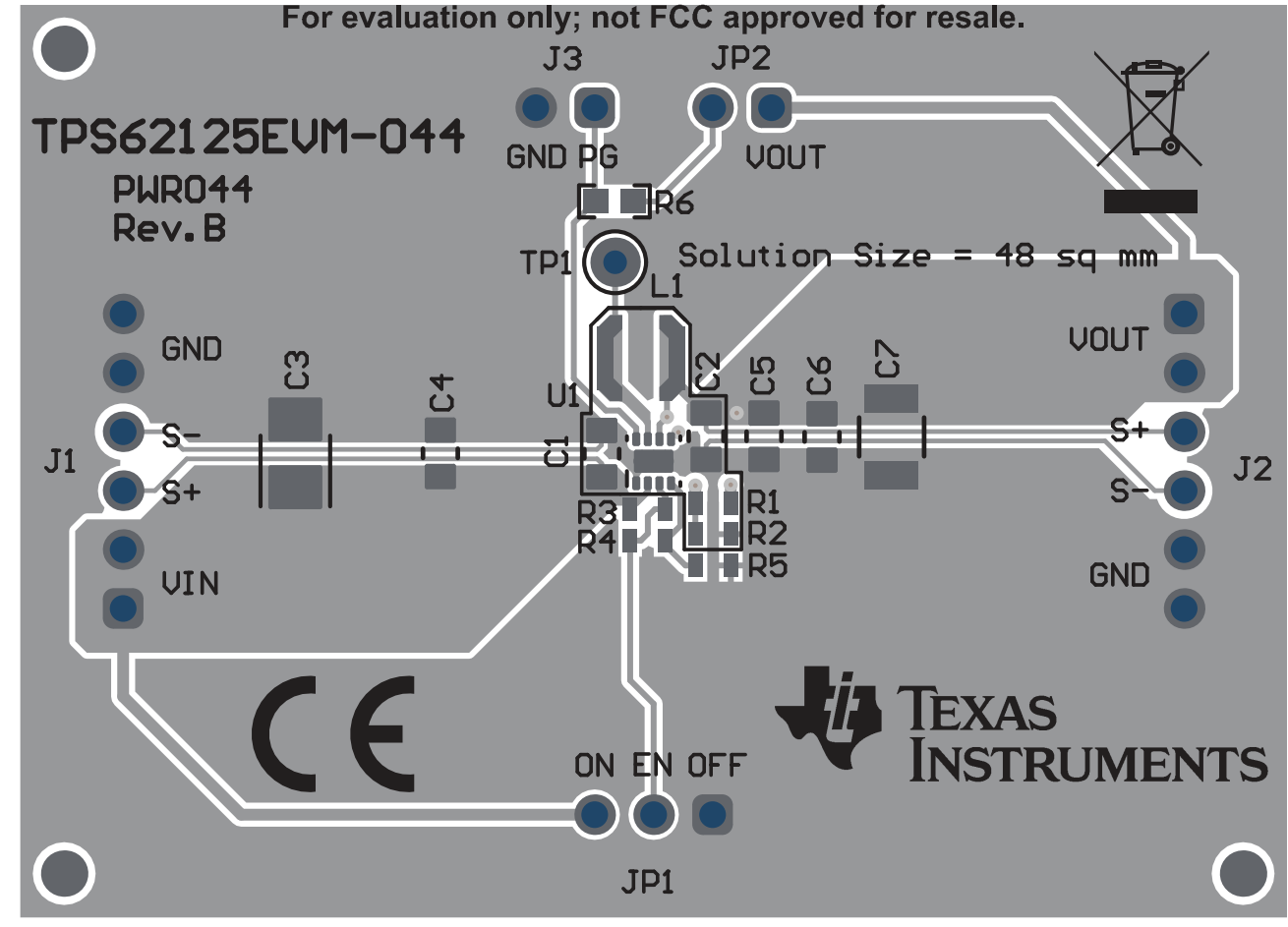

Figure 4-1. Revision B Top Assembly Layer

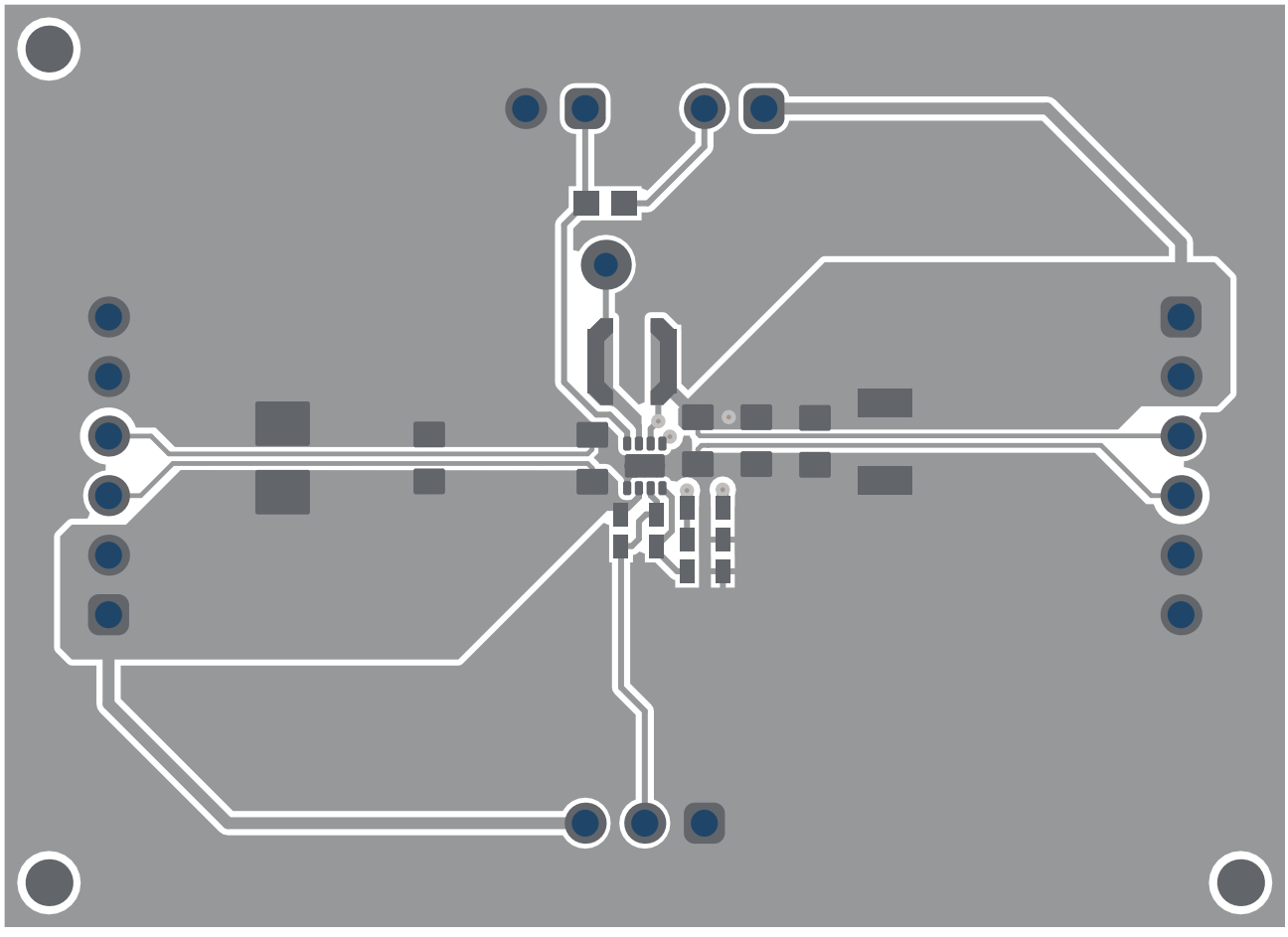

Figure 4-2. Revision B Top Layer

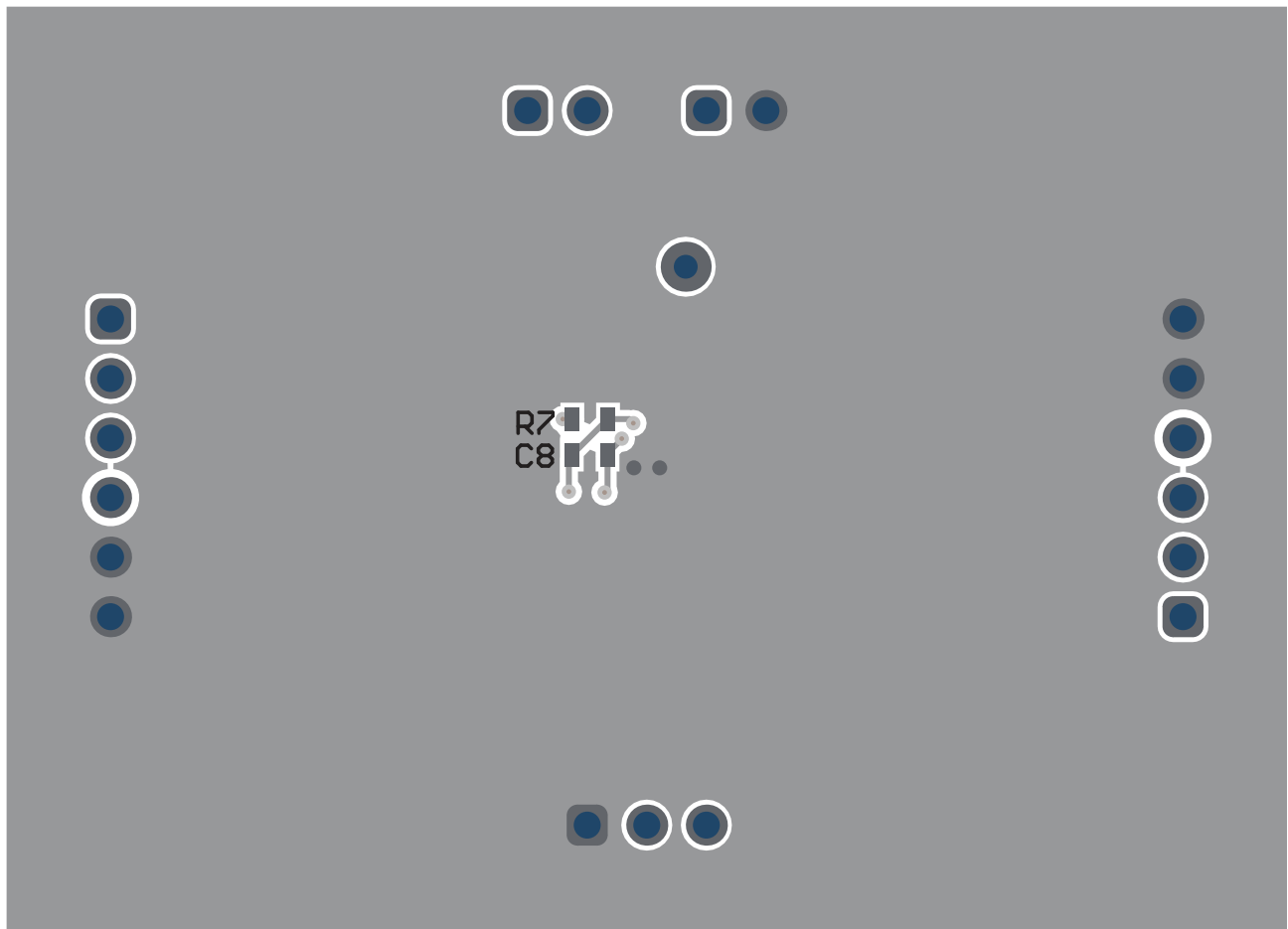
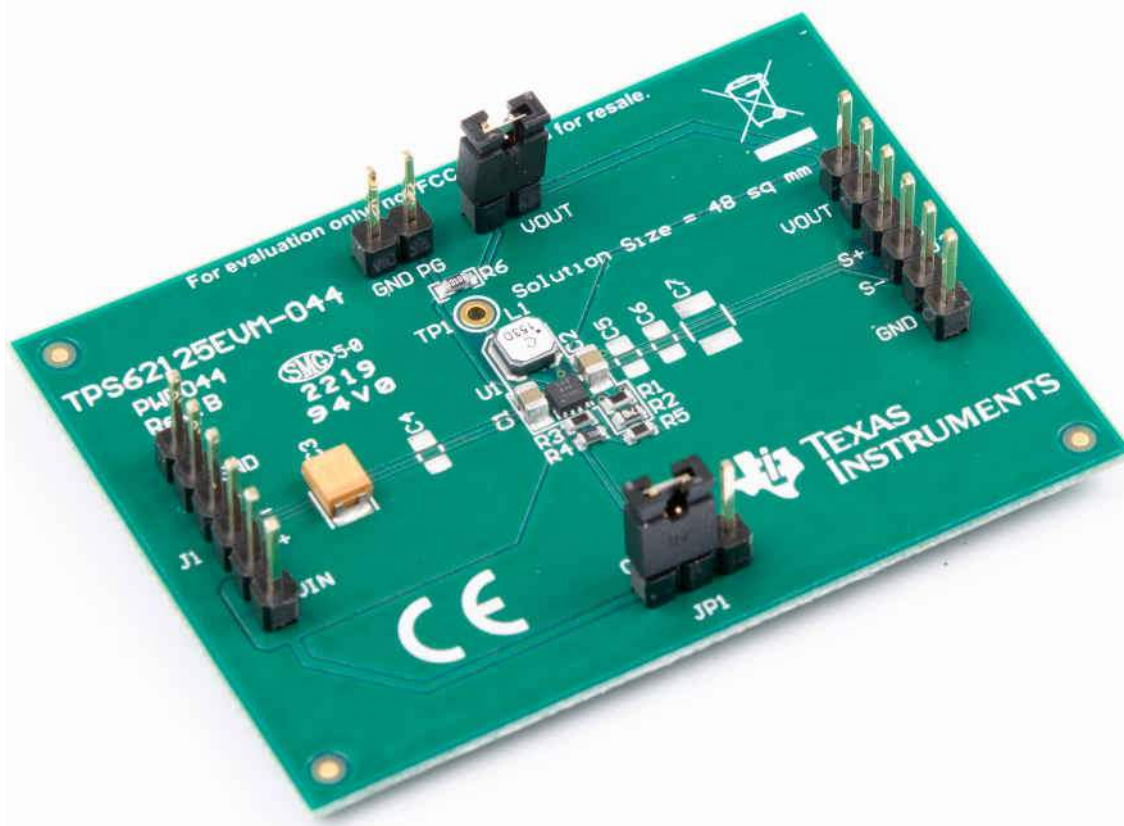
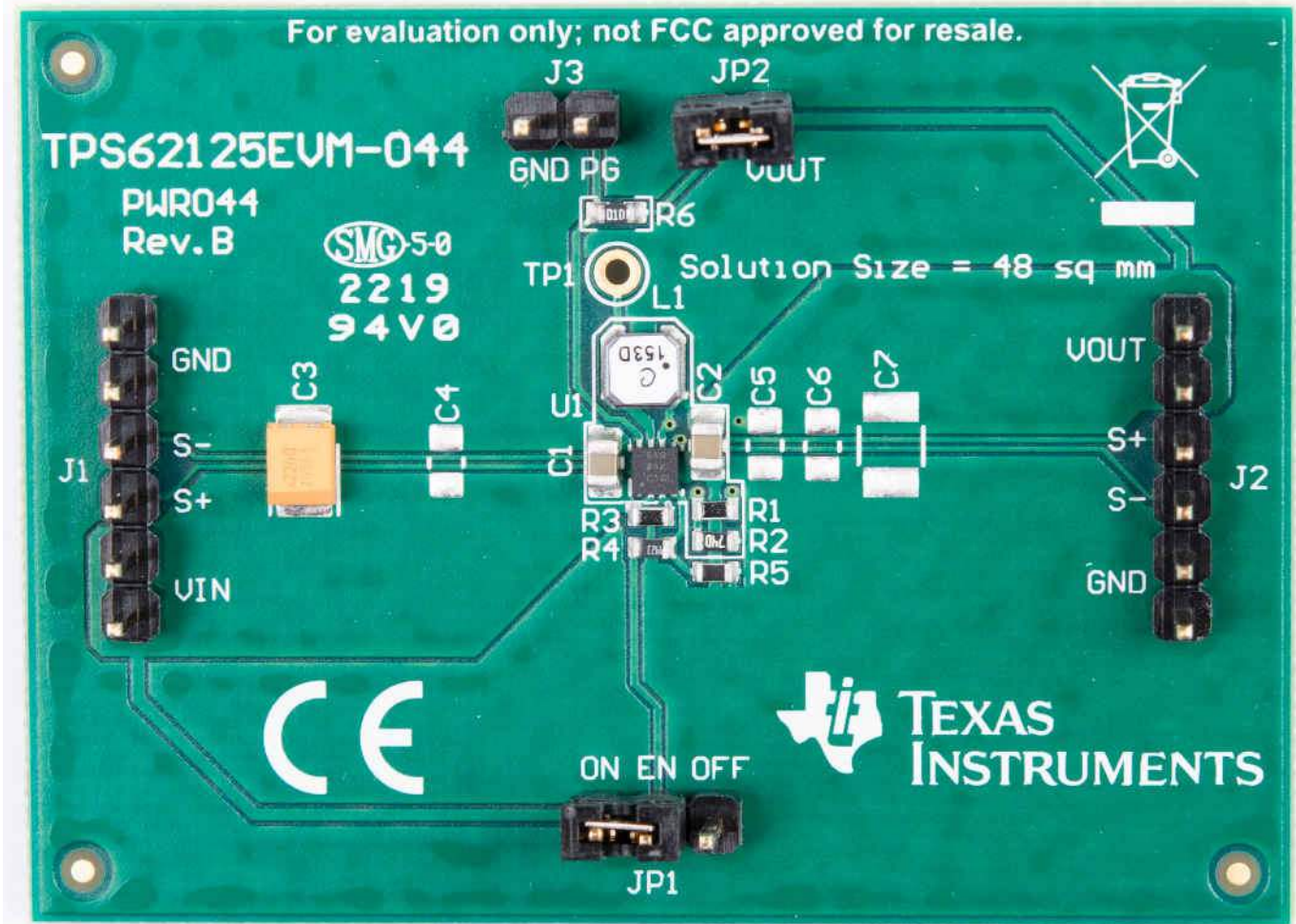

Figure 4-3. Revision B Bottom Layer

5 TPS62125EVM-044 Photos





6 Schematic and Bill of Materials

This section provides the TPS62125EVM-044 revision B schematic and bill of materials.

6.1 Schematic

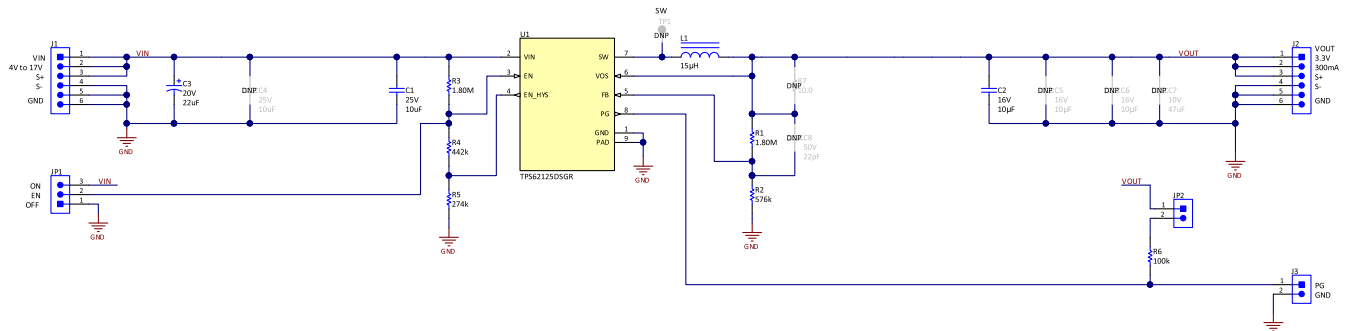

Figure 6-1. Revision B TPS62125EVM-044 Schematic

6.2 Bill of Materials

Table 6-1. Revision B TPS62125EVM-044 Bill of Materials

Count	RefDes	Value	Description	Size	Part Number	MFR
1	C1	10 µF	Capacitor, Ceramic, 25V, X5R, ±20%	0805	GRM21BR61E106MA73L	Murata
1	C2	10 µF	Capacitor, Ceramic, 16V, X5R, ±20%	0805	GRM21BR61C106ME15L	Murata
1	C5	22 µF	Capacitor, Tantalum Polymer, 22 uF, 20 V, +/- 20%, 0.09 ohm	3528[B]	TCJB226M020R0090	AVX
1	L1	15 µH	Inductor, Shielded Drum Core, Ferrite, 0.59 A, 0.44 ohm	3.3 X 3.3 mm	LPS3314-153MRB	Coilcraft
2	R1, R4	1.8M	Resistor, Chip, 1/16W, 1%	0603	Std	Std
1	R2	442k	Resistor, Chip, 1/16W, 1%	0603	Std	Std
1	R3	274k	Resistor, Chip, 1/16W, 1%	0603	Std	Std
1	R5	576k	Resistor, Chip, 1/16W, 1%	0603	Std	Std
1	R6	100k	Resistor, Chip, 1/16W, 1%	0603	Std	Std
1	U1	TPS62125	IC, 3V-17V, 300mA Buck Converter with Adjustable Enable Threshold and Hysteresis	WS0N-8	TPS62125DSG	TI

7 Revision A files

7.1 Board Layout

This section provides the TPS62125EVM-044 revision A board layout and illustrations.

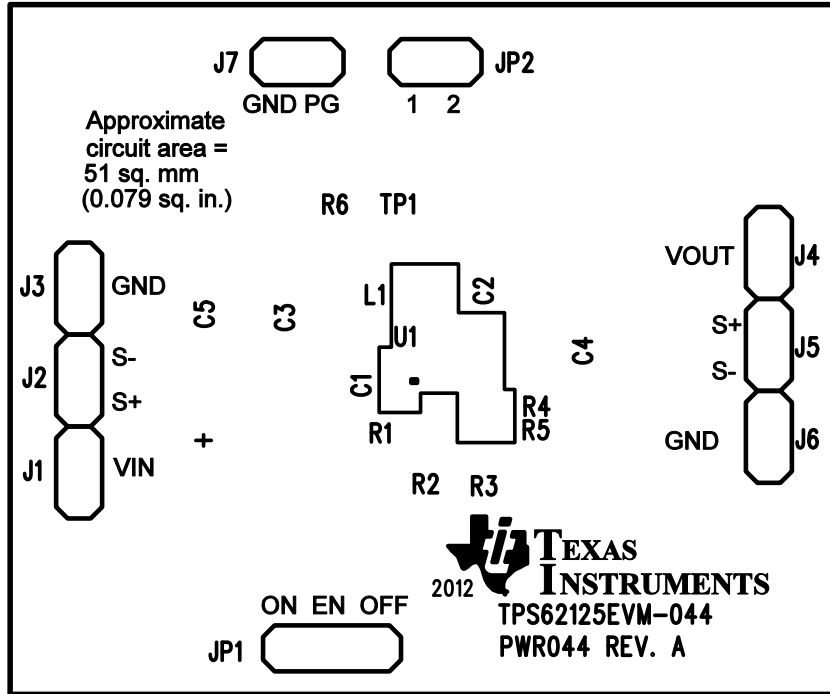

Figure 7-1. Revision A Top Silk Layer

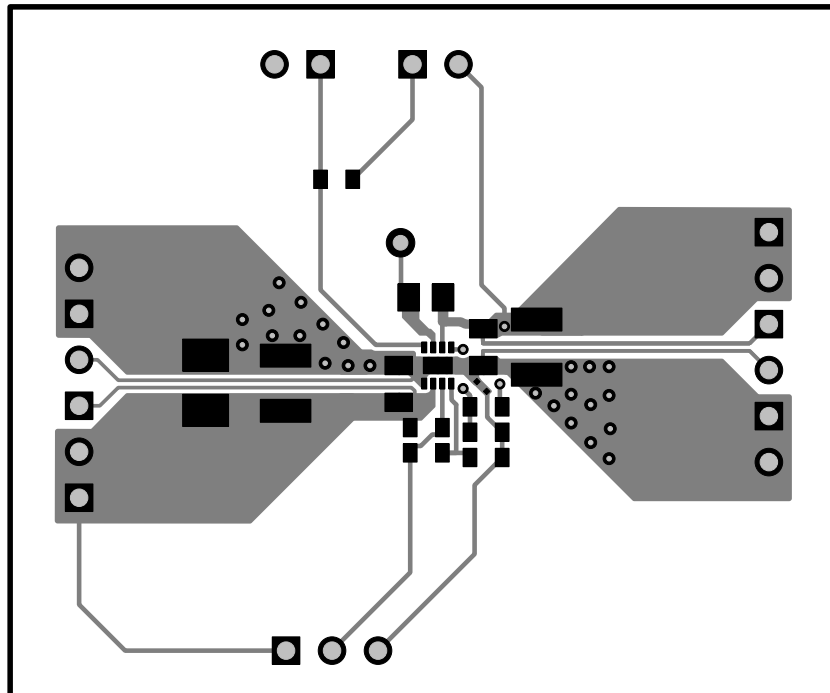

Figure 7-2. Revision A Top Layer

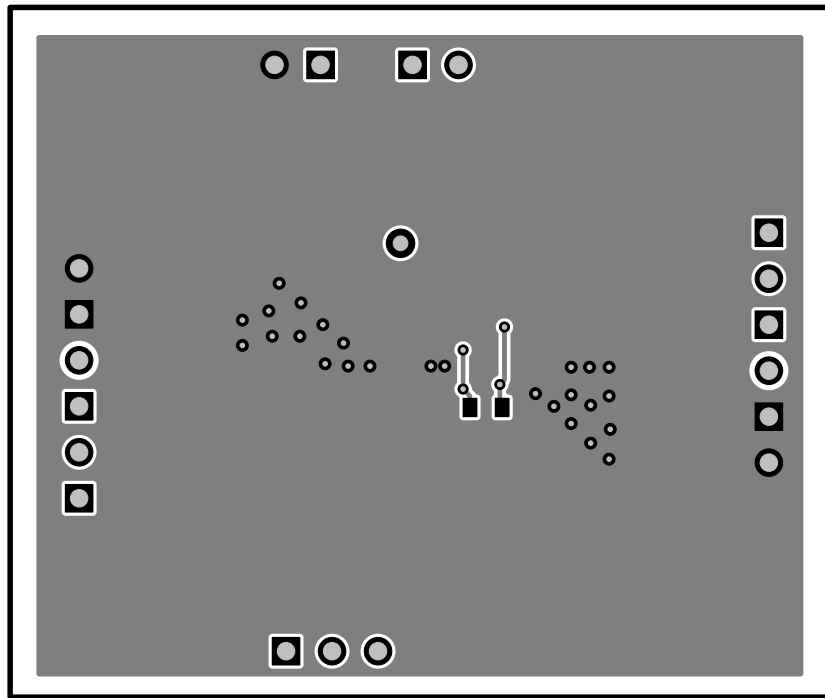

Figure 7-3. Revision A Bottom Layer

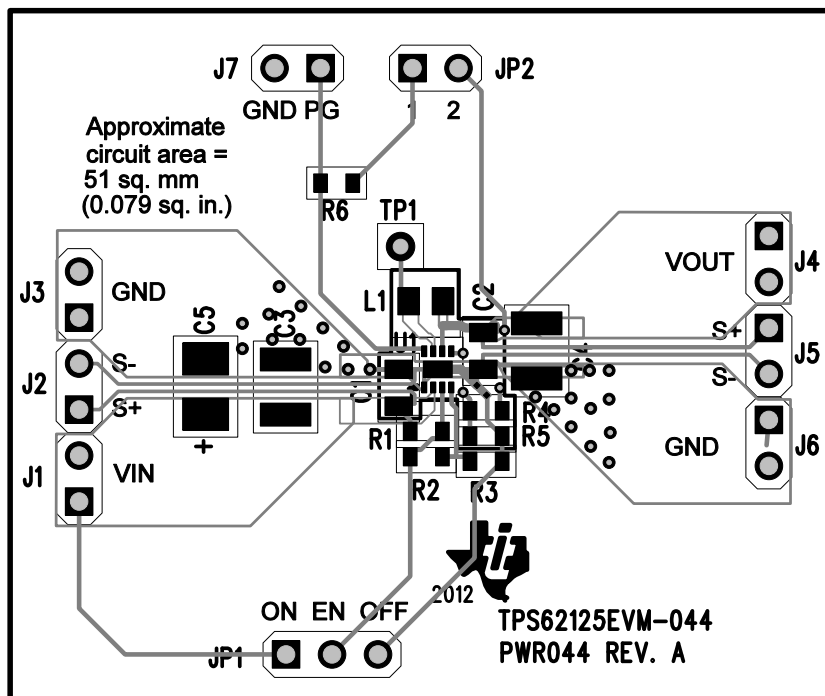

Figure 7-4. Revision A Top Assembly Layer

7.2 Schematic and Bill of Materials

This section provides the TPS62125EVM-044 revision A schematic and bill of materials.

7.2.1 Schematic

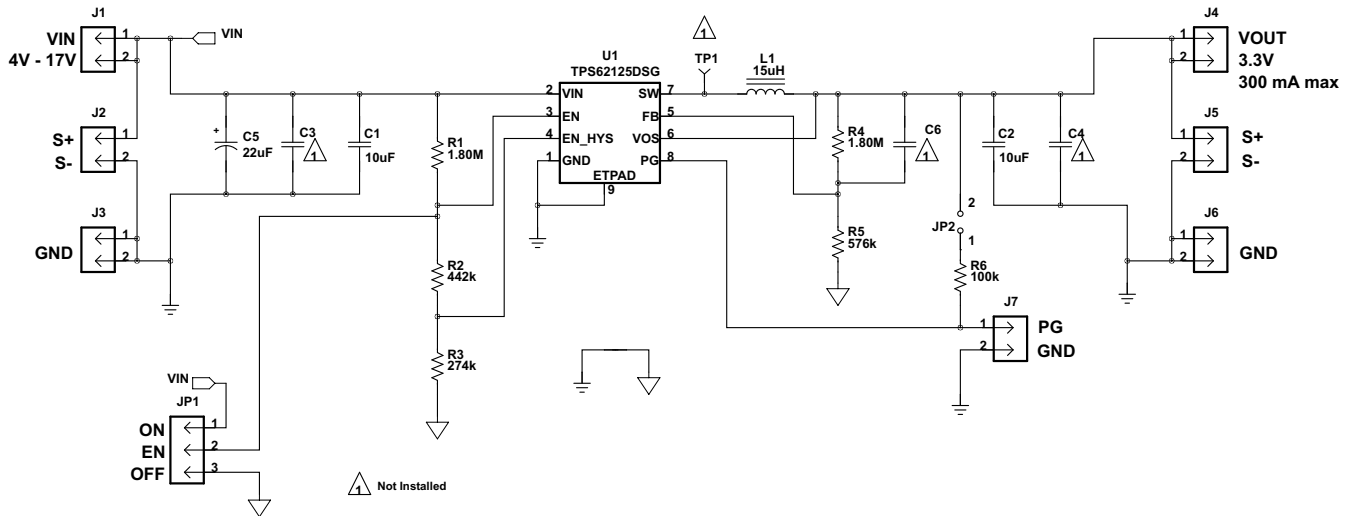

Figure 7-5. Revision A TPS62125EVM-044 Schematic

7.2.2 Bill of Materials

Table 7-1. Revision A TPS62125EVM-044 Bill of Materials

Count	RefDes	Value	Description	Size	Part Number	MFR
1	C1	10 µF	Capacitor, Ceramic, 25V, X5R, ±20%	0805	GRM21BR61E106MA73L	Murata
1	C2	10 µF	Capacitor, Ceramic, 16V, X5R, ±20%	0805	GRM21BR61C106ME15L	Murata
1	C5	22 µF	Capacitor, POSCAP	3528[B]	20TQC22MYFB or 25TQC15MYFB	Panasonic
1	L1	15 µH	Inductor, Power, 0.56 A, 275-mΩ, ±20%	3 X 2.5 mm	VLF302515MT-150M or XFL3012-153ME	TDK or Coilcraft
2	R1, R4	1.8M	Resistor, Chip, 1/16W, 1%	0603	Std	Std
1	R2	442k	Resistor, Chip, 1/16W, 1%	0603	Std	Std
1	R3	274k	Resistor, Chip, 1/16W, 1%	0603	Std	Std
1	R5	576k	Resistor, Chip, 1/16W, 1%	0603	Std	Std
1	R6	100k	Resistor, Chip, 1/16W, 1%	0603	Std	Std
1	U1	TPS62125	IC, 3V-17V, 300mA Buck Converter with Adjustable Enable Threshold and Hysteresis	WSO8	TPS62125DSG	TI

8 Revision History

NOTE: Page numbers for previous revisions may differ from page numbers in the current version.

Changes from Revision B (April 2019) to Revision C (June 2021) Page

- Updated the numbering format for tables, figures, and cross-references throughout the document.3
- Updated user's guide title..... 3

Changes from Revision A (March 2012) to Revision B (April 2019) Page

- EVM PCB to include revision B. New PCB, Schematic, and BOM..... 1
- References to EVM components updated throughout document..... 1
- Added NOTE: In July 2019, this EVM..... 1
- Changed the *TPS62125EVM-044 Test Results* section..... 6
- Add the TPS62125EVM-044 Photos..... 10
- Added Appendix A..... 13

Changes from Revision * (March 2012) to Revision A (March 2012) Page

- Changed "delivers 250 mA" To: "delivers 300 mA" in the first paragraph..... 1
 - Changed "The TPS62125 is a 250-mA" To: "The TPS62125 is a 300-mA" in the Introduction..... 3
 - Changed the Output current Max value From: 250 mA To: 300 mA in [Table 1-1](#) 3
-

IMPORTANT NOTICE AND DISCLAIMER

TI PROVIDES TECHNICAL AND RELIABILITY DATA (INCLUDING DATA SHEETS), DESIGN RESOURCES (INCLUDING REFERENCE DESIGNS), APPLICATION OR OTHER DESIGN ADVICE, WEB TOOLS, SAFETY INFORMATION, AND OTHER RESOURCES "AS IS" AND WITH ALL FAULTS, AND DISCLAIMS ALL WARRANTIES, EXPRESS AND IMPLIED, INCLUDING WITHOUT LIMITATION ANY IMPLIED WARRANTIES OF MERCHANTABILITY, FITNESS FOR A PARTICULAR PURPOSE OR NON-INFRINGEMENT OF THIRD PARTY INTELLECTUAL PROPERTY RIGHTS.

These resources are intended for skilled developers designing with TI products. You are solely responsible for (1) selecting the appropriate TI products for your application, (2) designing, validating and testing your application, and (3) ensuring your application meets applicable standards, and any other safety, security, regulatory or other requirements.

These resources are subject to change without notice. TI grants you permission to use these resources only for development of an application that uses the TI products described in the resource. Other reproduction and display of these resources is prohibited. No license is granted to any other TI intellectual property right or to any third party intellectual property right. TI disclaims responsibility for, and you will fully indemnify TI and its representatives against, any claims, damages, costs, losses, and liabilities arising out of your use of these resources.

TI's products are provided subject to [TI's Terms of Sale](#) or other applicable terms available either on ti.com or provided in conjunction with such TI products. TI's provision of these resources does not expand or otherwise alter TI's applicable warranties or warranty disclaimers for TI products.

TI objects to and rejects any additional or different terms you may have proposed.

Mailing Address: Texas Instruments, Post Office Box 655303, Dallas, Texas 75265
Copyright © 2022, Texas Instruments Incorporated