

PART NUMBER	REVISION	DESCRIPTION	FEED TYPE
2151519-1	F	FINE CRIMP HEIGHT ADJUST	MECHANICAL
2151519-2	F	FINE CRIMP HEIGHT ADJUST	PNEUMATIC
3-2151519-2	F	FINE CRIMP HEIGHT ADJUST	DOUBLE ACTING PNEUMATIC WITH SENSORS
5-2151519-1	1	SEAL STRIPPER CRIMPER TERMINATING UNIT	MECHANICAL
5-2151519-2	1	SEAL STRIPPER CRIMPER TERMINATING UNIT	PNEUMATIC
7-2151519-1	F	MECHANICAL AND CRIMP TOOLING KIT	MECHANICAL
7-2151519-2	F	PNEUMATIC AND CRIMP TOOLING KIT	PNEUMATIC
7-2151519-7	A	CRIMP TOOLING KIT	-

ATLANTIC VERSION TERMINATOR INTERFACE ADAPTER

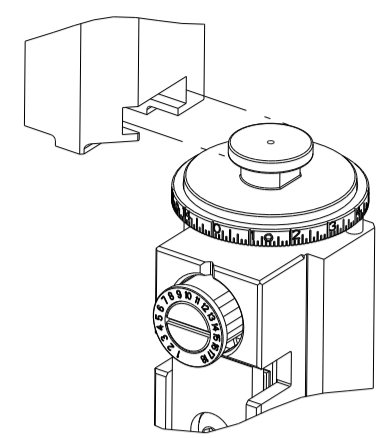

APPLICATOR DATA		
CRIMP	SIZE	TYPE
WIRE	1.57 mm [.062]	F
INSUL	3.30 mm [.130]	O

APPLICATOR INSTRUCTIONS 408-35042

TERMINAL DATA: TE TERMINAL		TE CRIMP SPECIFICATION	
TERMINAL NAME: HPF 1.5mm SENSORCONTACT ASSEMBLY AND BODY			
WIRE STRIP LENGTH	INSULATION DIAMETER RANGE		
4.20-4.60 mm [.165-.181 IN]	Ø 1.40-1.90 mm [.055-.075 IN]		
TERMINAL APPLICATION SPECIFICATION	114-18912		

TERMINALS APPLIED				
TE TERMINAL	TE TERMINAL	TE SEAL	TE SEAL	SEAL INSULATION DIAMETER RANGE
1563623-2	2325198-3	9-963530-1	963530-1	1.4-1.9 mm
2292290-1		9-964971-1	964971-1	1.2-1.6 mm
2208362-3		967067-1		1.4-2.1 mm
		2297817-1	2297817-2	1.4-1.7 mm

WIRE SIZE	CRIMP HEIGHT mm [INCH]	CRIMP HEIGHT REFERENCE SETTING
0.50mm2	0.99+/-0.03 [.039+/- .001]	8.5

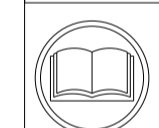

- 1. RECOMMENDED SPARE PARTS
- 2. REFER TO SUPPLIED INSTRUCTION SHEET FOR CLEANING, LUBRICATION AND STORAGE OF APPLICATOR.
- 3. APPLY PART NUMBER 2-23419-6 LOCTITE TO THREADS OF ITEM 242.
- 4. CRIMP HEIGHT REFERENCE SETTING WAS THE SETTING USED WHEN THE APPLICATOR WAS QUALIFIED AT THE FACTORY. ADJUSTMENT MAY BE NECESSARY WHEN RUNNING APPLICATOR IN THE FIELD.
- 5. APPLY TORO-SEAL IN ALLEN SOCKET TO FILL HOLE AFTER FLAT HD HAS BEEN ADJUSTED TO CORRECT HEIGHT AT QUALIFICATION. APPLY #1-23419-5 LOC-TITE TO THREADS.
- 6. UNLESS SPECIFIED OTHERWISE TORQUE VALUES SHALL BE USED PER DOCUMENT, 101-35000.
- 7. TERMINAL LUBRICANT IS RECOMMENDED.
- 8. THIS APPLICATOR IS EQUIPPED WITH THE DOUBLE ACTING FEED WITH SENSORS AND IS APPLICATION SPECIFIC. IT DOES NOT REQUIRE ITEMS 49 & 248.

***WARNING**
ON INSTALLATION, SET WIRE DISC TO CRIMP HEIGHT REFERENCE SETTING FOR LARGEST WIRE SIZE. CRIMP HEIGHT REFERENCE SETTINGS GREATER THAN THE VALUE SHOWN MAY CAUSE DAMAGE TO THE CRIMP TOOLING. REFER TO THE INSTRUCTION SHEET FOR PROPER SETUP AND ADJUSTMENTS.

LOC	DIST	REVISIONS					
A	66	P	LTN	DESCRIPTION	DATE	OWN	APVD
		E1		ECR-20-010242	20JUL2020	FZ	TE
		E2		ECR-21-001818	11FEB2021	JWC	RK
		E3		ECR-23-178326	13JUN2023	FZ	RK
		F		ECR-23-179249	22JUN2023	TB	TE

-	1	1	1	1	1	1	1	2-1803945-0	TONKER	300
-	1	1	1	1	1	1	1	22278-9	SPRING, COMPRESSION	299
-	2	2	2	2	2	2	2	4-18032-3	SCR, SET, FLT PNT, M3 X 6.0	298
-	1	1	1	1	1	1	1	1803944-1	SPACER, TONKER	297
-	-	-	1	1	-	-	-	2-1803583-1	APPLICATOR BASIC ASSEMBLY, SF	292
-	-	-	-	-	1	-	-	2844950-1	AIR FEED MODULE	290
-	1	-	1	-	-	1	-	2119641-1	FEED CAM, AIR FEED	248
-	1	1	1	1	1	1	1	2119082-7	CAM, SNAIL, INSULATION ADJUSTMENT	244
-	1	1	1	1	1	1	1	2079764-1	WASHER, WAVE SPRING, CREST-TO-CREST	243
-	1	1	1	1	1	1	1	2119083-1	RETAINER, INSULATION DIAL	242
-	1	1	1	1	1	1	1	7-18023-7	SCR, SKT HD CAP M3 X 4.0	241
-	-	1	-	1	-	-	1	2119580-1	MECHANICAL FEED ASSEMBLY	239
-	1	-	1	-	-	1	-	2844940-1	AIR FEED MODULE	238
-	REF	REF	REF	REF	REF	REF	REF	994970-2	COUNTER, MAGNETIC	164
-	1	1	1	1	1	1	1	1-18028-2	WASHER, FLAT, REG M4	119
-	1	1	1	1	1	1	1	2119955-1	ASSY, LUBRICATOR, SIDE FEED	113
-	1	1	1	1	1	1	1	2844908-1	SCREW, LOCKING	99
-	1	1	1	1	1	1	1	2844907-1	POST, LOCKING	98
-	1	1	1	1	1	1	1	455888-4	SPACER, CRIMPER	82
-	1	1	1	1	1	1	1	1803607-3	DOCUMENTATION PACKAGE	71
-	1	1	1	1	1	1	1	2119740-1	TAG, IDENTIFICATION	67
-	2	2	2	2	2	2	2	2168078-1	SCREW, DRIVE, RH, RoHS, 2 x .188	66
-	1	1	1	1	1	1	1	2168083-2	SCR, SKT HD CAP, RoHS, M4 X 8.0	60
-	1	1	1	1	1	1	1	5-18022-5	SCR, HEX HD CAP, M4 X 6.0	59
-	1	1	1	1	1	1	1	985575-3	SCR, FLT SKT HD CAP M3 X 10.0	57
-	1	1	1	1	1	1	1	1338685-1	PAWL, FEED	56
-	4	4	4	4	4	4	4	2168083-3	SCR, SKT HD CAP, RoHS, M4 X 12.0	54
-	2	2	2	2	2	2	2	2168083-3	SCR, SKT HD CAP, RoHS, M4 X 12.0	53
-	1	2	1	2	-	1	2	18023-9	SCR, SKT HD CAP M4 X 6.0	49
-	-	1	-	1	-	-	1	2119652-1	FEED CAM, PRE FEED	48
-	-	1	-	1	-	-	1	2119653-1	FEED CAM, POST FEED	47
-	1	1	-	-	1	1	1	1803583-9	APPLICATOR BASIC ASSEMBLY, SF	46
-	1	1	1	1	1	1	1	1803515-1	RAM ASSEMBLY, SF ATLANTIC	44
-	1	1	1	1	1	1	1	1803602-1	SCR, BHSC, RoHS (M8 X 25)	41
-	1	1	1	1	1	1	1	1752356-6	SUPPORT, TERMINAL	34
-	2	2	2	2	2	2	2	2079383-5	SCR, BHSC, RoHS (M4 X 20)	33
-	2	2	2	2	2	2	2	3-2844962-0	SPACER, CYLINDRICAL, STRIP GUIDE	30
-	1	1	1	1	1	1	1	2844992-1	ASSEMBLY, STRIP GUIDE	29
-	1	1	1	1	1	1	1	1-455888-0	SPACER, CRIMPER	28
-	1	1	1	1	1	1	1	1320928-2	STRIP GUIDE	24
-	1	1	-	-	1	1	1	2168083-2	SCR, SKT HD CAP, RoHS, M4 X 8.0	21
-	2	2	1	1	2	2	2	1-18028-2	WASHER, FLAT, REG M4	20
-	1	1	-	-	1	1	1	2119533-1	STRIPPER, SIDE FEED	19
-	1	1	1	1	1	1	1	2119806-1	INSERT, SHEAR	13
-	1	1	1	1	1	1	1	3-22280-3	SPRING, COMPRESSION	12
-	1	1	1	1	1	1	1	1-356885-4	STOP, SHEAR	11
-	1	1	1	1	1	1	1	2119805-1	SHEAR HOLDER, FRONT	10
-	1	1	1	1	1	1	1	318707-1	FLOATING SHEAR, FRONT	9
1	2	2	1	1	1	1	1	1333332-2	ANVIL, COMBINATION, SPECIAL	8
-	1	1	1	1	1	1	1	2-240641-1	SPACER	7
-	-	-	-	-	-	-	-	-	-	6
-	1	1	1	1	1	1	1	2119781-1	DEPRESSOR, SHEAR	5
-	1	1	1	1	1	1	1	238011-4	BLOCK, CRIMPER SPACER	4
1	2	2	1	1	1	1	1	2-1633996-7	CRIMPER, INSULATION SPECIAL	3
-	1	1	1	1	1	1	1	1-455888-3	SPACER, CRIMPER	2
1	2	2	1	1	1	1	1	1-456403-5	CRIMPER, WIRE PREMIUM	1

ATLANTIC VERSION
Shown on sheets 1 of 4 & 2 of 4
(Pacific version shown on sheets 3 of 4 & 4 of 4)

DIMENSIONS:		TOLERANCES UNLESS OTHERWISE SPECIFIED:		MATERIAL:		FINISH:		WEIGHT:		SCALE:		SHEET:		REV:	
mm	0 PLC ±	1 PLC ±	2 PLC ±	3 PLC ±	4 PLC ±	ANGLES	FINISH			A	00779	2151519	1	4	F

LOC	DIST	REVISIONS					
A	66	P	LTN	DESCRIPTION	DATE	DWN	APVD
		-		SEE SHEET 1			

FEED TYPE MECHANICAL

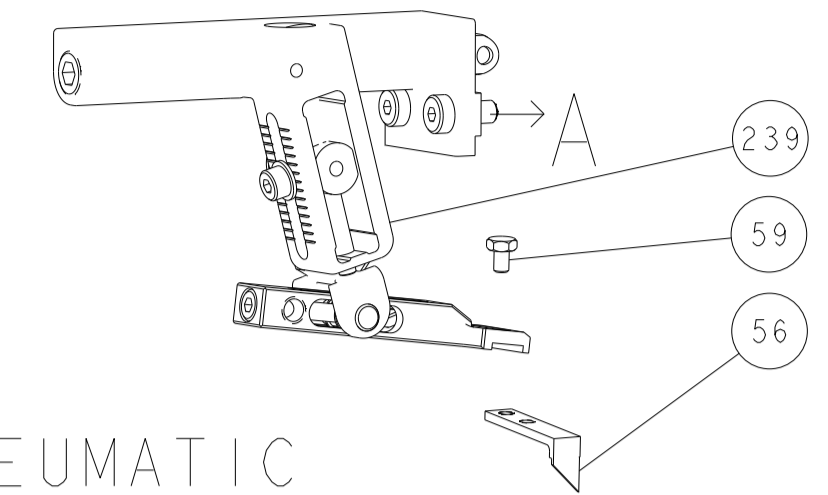

PNEUMATIC

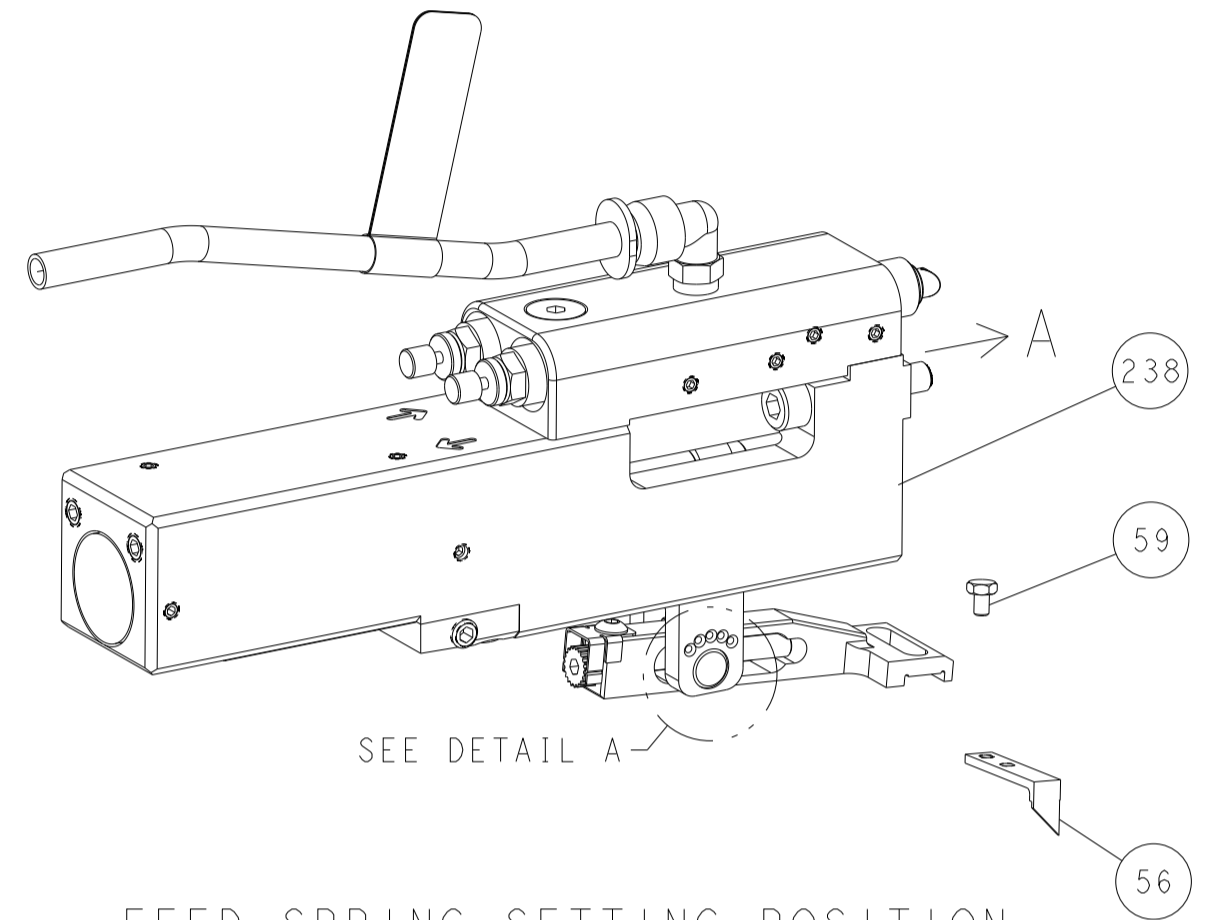

FEED SPRING SETTING POSITION (SHOWN FROM REAR SIDE)

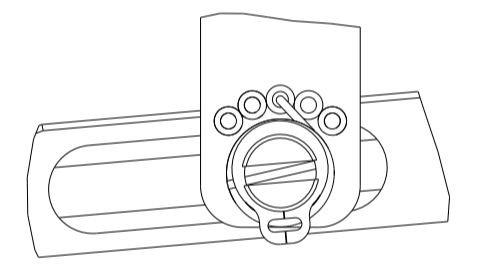

DETAIL A

DOUBLE ACTING PNEUMATIC WITH SENSORS

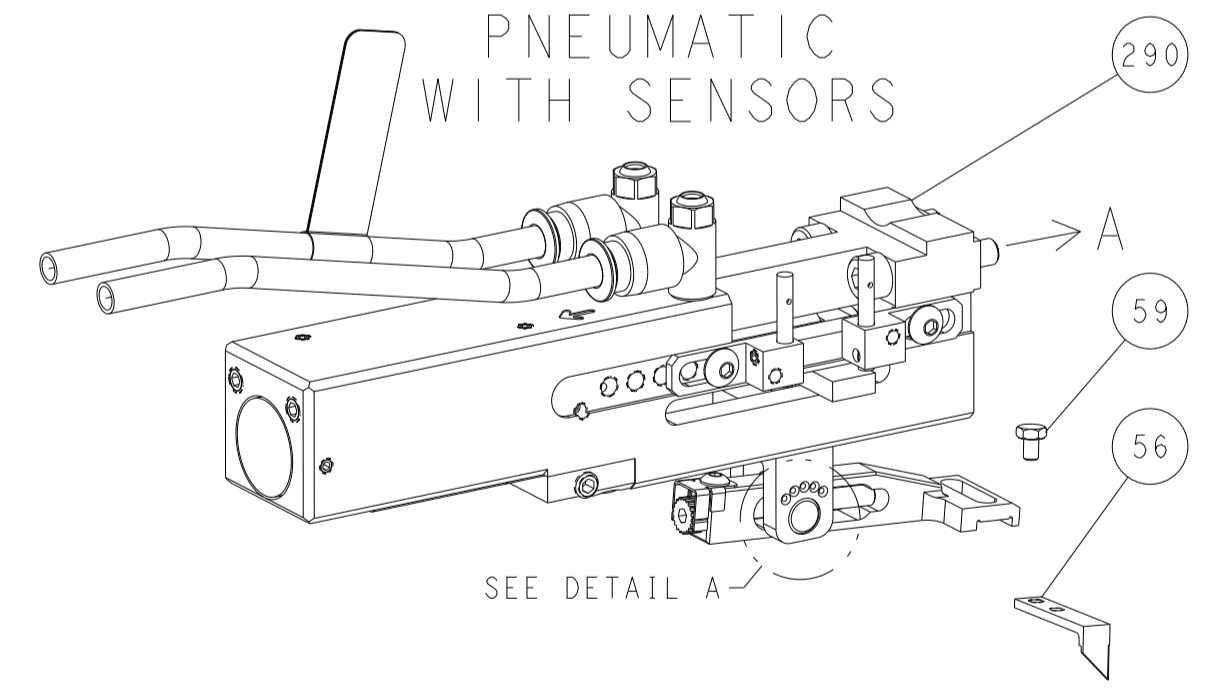

CAM POSITIONS

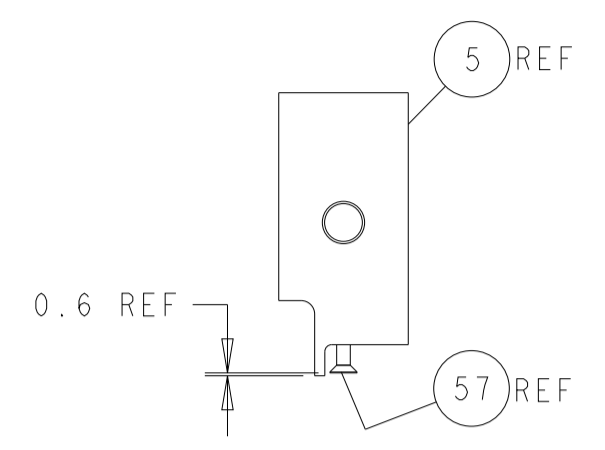
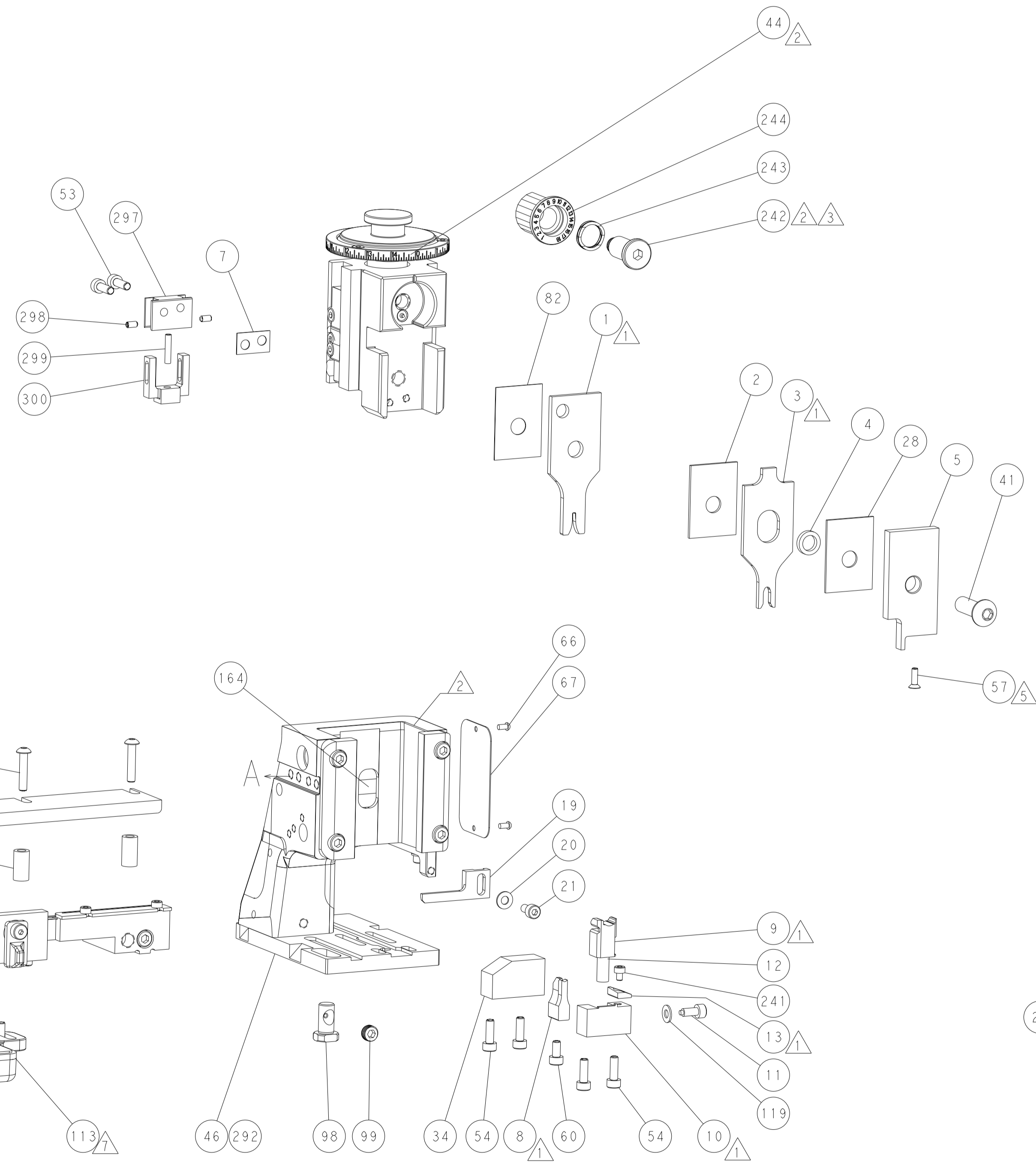
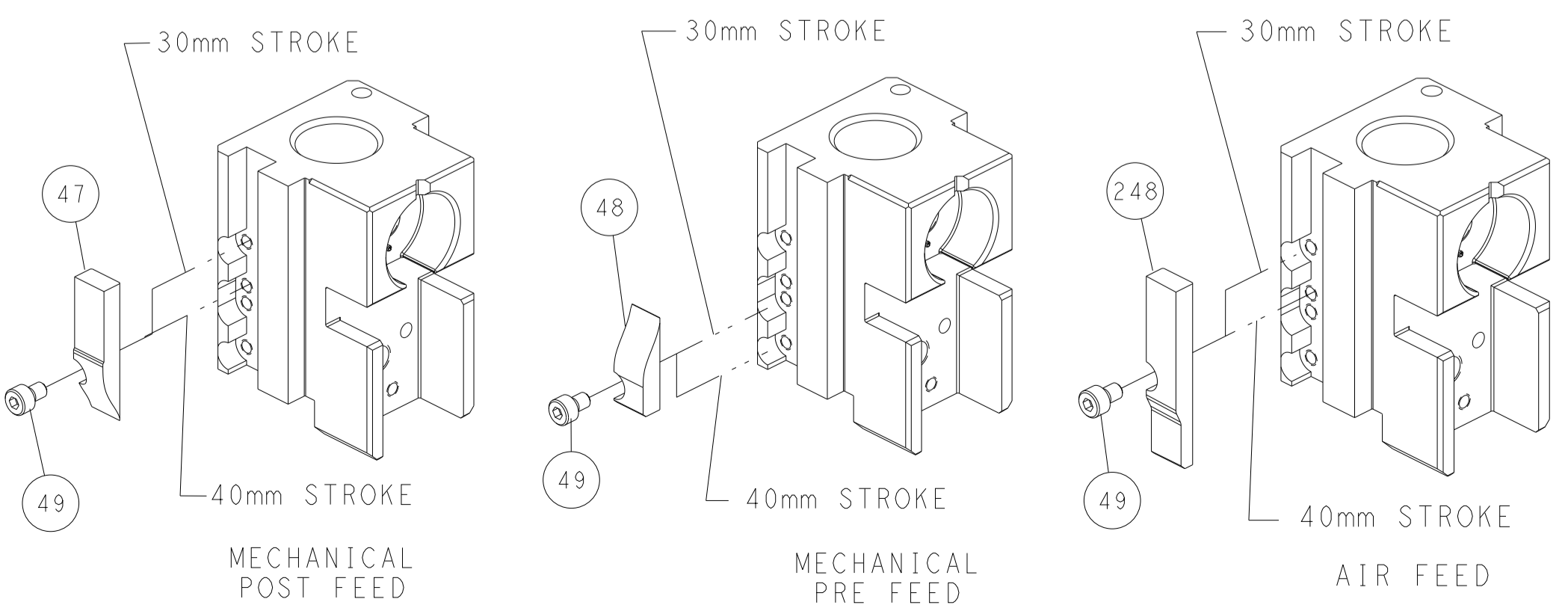

SHEAR DEPRESSOR DETAIL

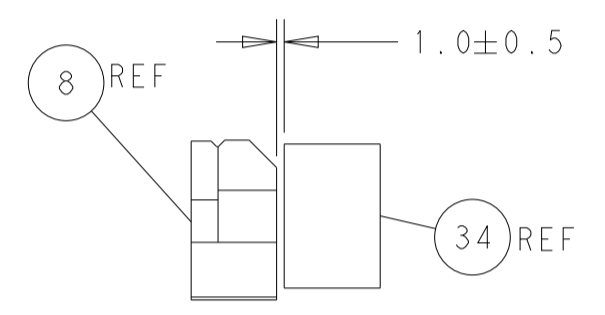

TERMINAL SUPPORT LOCATION

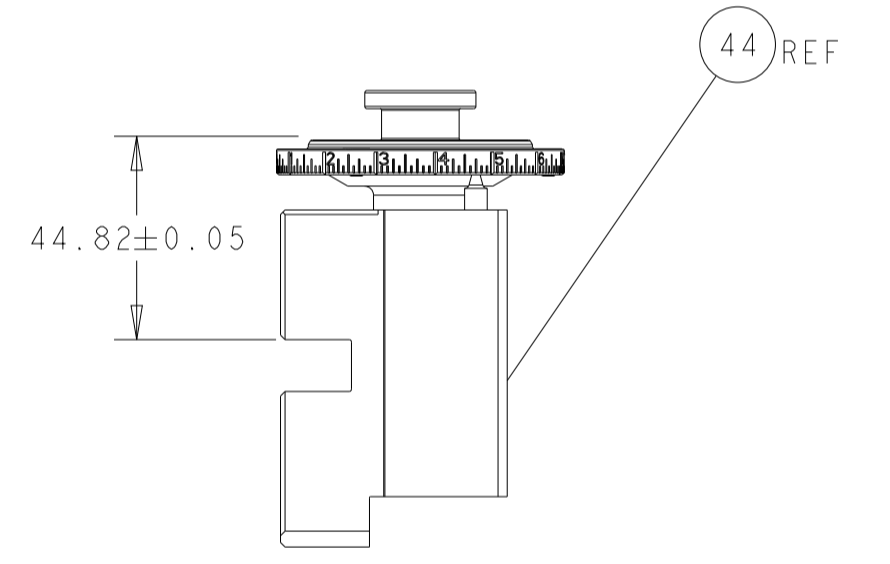

RAM SET-UP

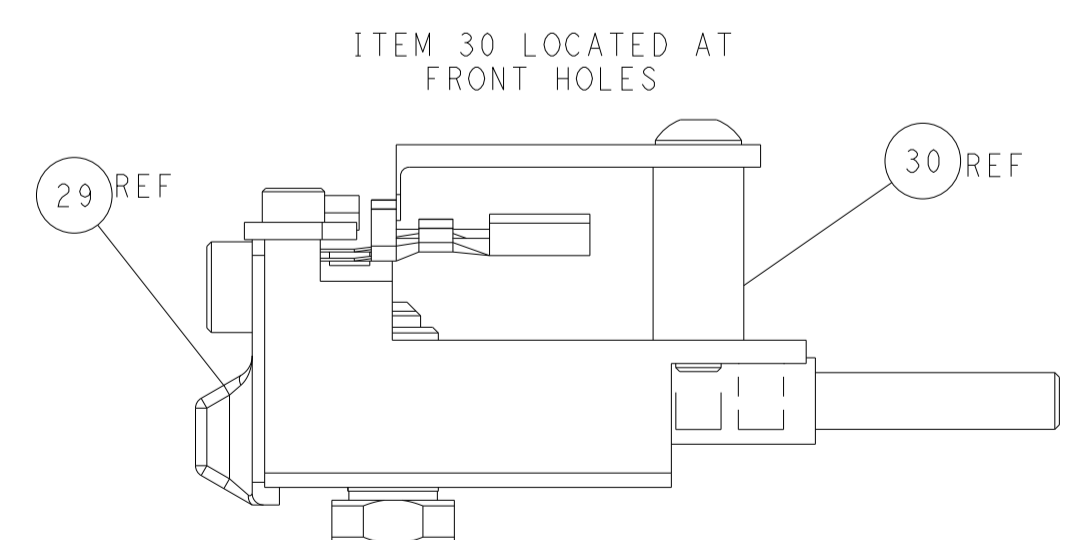

FEED TRACK POSITION GUIDE BY INSULATION BARREL

ATLANTIC VERSION
 Shown on sheets 1 of 4 & 2 of 4
 (Pacific version shown on sheets 3 of 4 & 4 of 4)

DIMENSIONS:		TOLERANCES UNLESS OTHERWISE SPECIFIED:		DWG		TE Connectivity	
mm	0 PLC ±	1 PLC ±	2 PLC ±	Y. YIN	14MAR2013	Harrisburg, PA 17105-3608	
	3 PLC ±	4 PLC ±	ANGLES ±	CHK G. BAILEY	14MAR2013	NAME Ocean Side Feed Applicator	
MATERIAL	FINISH	WEIGHT	SCALE	APVD U. GUO	14MAR2013	RESTRICTED TO	
			1:2	PRODUCT SPEC		SIZE CAGE CODE DRAWING NO	
				APPLICATION SPEC		A1 00779 ©=2151519	
				Customer Accessible Production Drawing		SHEET 2 OF 4 REV F	

PART NUMBER	REVISION	DESCRIPTION	FEED TYPE
2-2151519-1	F	FINE CRIMP HEIGHT ADJUST	MECHANICAL
2-2151519-2	F	FINE CRIMP HEIGHT ADJUST	PNEUMATIC
4-2151519-2	F	FINE CRIMP HEIGHT ADJUST	DOUBLE ACTING PNEUMATIC WITH SENSORS
7-2151519-7	A	CRIMP TOOLING KIT	-

PACIFIC VERSION TERMINATOR INTERFACE ADAPTER

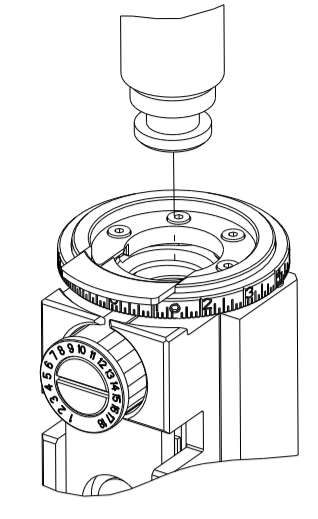

APPLICATOR DATA		
CRIMP	SIZE	TYPE
WIRE	1.57 mm [.062]	F
INSUL	3.30 mm [.130]	O

APPLICATOR INSTRUCTIONS
408-35042

TERMINAL DATA: TE TERMINAL		TE CRIMP SPECIFICATION	
TERMINAL NAME: HPF 1.5mm SENSORKONTAKT ASSEMBLY AND BODY			
WIRE STRIP LENGTH		INSULATION DIAMETER RANGE	
4.20-4.60 mm [.165-.181 IN]		Ø 1.40-1.90 mm [.055-.075 IN]	
TERMINAL APPLICATION SPECIFICATION	114-18912		

TERMINALS APPLIED				SEAL INSULATION DIAMETER RANGE
TE TERMINAL	TE TERMINAL	TE SEAL	TE SEAL	
1563623-2	2325198-3	9-963530-1	963530-1	1.4-1.9 mm
2292290-1		9-964971-1	964971-1	1.2-1.6 mm
2208362-3		967067-1		1.4-2.1 mm
		2297817-1	2297817-2	1.4-1.7 mm

WIRE SIZE	CRIMP HEIGHT mm [INCH]	CRIMP HEIGHT REFERENCE SETTING
0.50mm ²	0.99 +/- 0.03 [.039 +/- .001]	8.5

- RECOMMENDED SPARE PARTS
- REFER TO SUPPLIED INSTRUCTION SHEET FOR CLEANING, LUBRICATION AND STORAGE OF APPLICATOR.
- APPLY PART NUMBER 2-23419-6 LOCTITE TO THREADS OF ITEM 242.
- CRIMP HEIGHT REFERENCE SETTING WAS THE SETTING USED WHEN THE APPLICATOR WAS QUALIFIED AT THE FACTORY. ADJUSTMENT MAY BE NECESSARY WHEN RUNNING APPLICATOR IN THE FIELD.
- APPLY TORQ-SEAL IN ALLEN SOCKET TO FILL HOLE AFTER FLAT HD HAS BEEN ADJUSTED TO CORRECT HEIGHT AT QUALIFICATION. APPLY #1-23419-5 LOC-TITE TO THREADS.
- 6. UNLESS SPECIFIED OTHERWISE TORQUE VALUES SHALL BE USED PER DOCUMENT, 101-35000.
- TERMINAL LUBRICANT IS RECOMMENDED.
- THIS APPLICATOR IS EQUIPPED WITH THE DOUBLE ACTING FEED WITH SENSORS AND IS APPLICATION SPECIFIC. IT DOES NOT REQUIRE ITEMS 49 & 151.

***WARNING**
 ON INSTALLATION, SET WIRE DISC TO CRIMP HEIGHT REFERENCE SETTING FOR LARGEST WIRE SIZE. CRIMP HEIGHT REFERENCE SETTINGS GREATER THAN THE VALUE SHOWN MAY CAUSE DAMAGE TO THE CRIMP TOOLING. REFER TO THE INSTRUCTION SHEET FOR PROPER SETUP AND ADJUSTMENTS.

PACIFIC VERSION
 Shown on sheets 3 of 4 & 4 of 4
 (Atlantic version shown on sheets 1 of 4 & 2 of 4)

LOC	DIST	REVISIONS					
A	66	P	LTN	DESCRIPTION	DATE	DWN	APVD
		-	-	SEE SHEET 1	-	-	-

-	1	1	1	2-1803945-0	TONKER		300
-	1	1	1	22278-9	SPRING, COMPRESSION		299
-	2	2	2	4-18032-3	SCR, SET, FLT PNT, M3 X 6.0		298
-	1	1	1	1803944-1	SPACER, TONKER		297
-	1	-	-	2844950-1	AIR FEED MODULE		290
-	1	1	1	2119082-7	CAM, SNAIL, INSULATION ADJUSTMENT		244
-	1	1	1	2079764-1	WASHER, WAVE SPRING, CREST-TO-CREST		243
3	-	1	1	2119083-1	RETAINER, INSULATION DIAL		242
-	1	1	1	7-18023-7	SCR, SKT HD CAP M3 X 4.0		241
-	-	-	1	2119580-1	MECHANICAL FEED ASSEMBLY		239
-	-	1	-	2844940-1	AIR FEED MODULE		238
-	REF	REF	REF	994970-2	COUNTER, MAGNETIC		164
8	-	-	1	2119641-2	FEED CAM, AIR FEED		151
-	1	1	1	2168083-8	SCR, SKT HD CAP, RoHS, M4 X 16		144
-	4	4	4	2168083-9	SCR, SKT HD CAP, RoHS, M4 X 20		143
-	-	-	1	2119653-2	FEED CAM, POST FEED		142
-	1	1	1	1-1803583-0	APPLICATOR BASIC ASSEMBLY, SF		141
-	1	1	1	1803516-1	RAM ASSEMBLY, SF PACIFIC		140
-	1	1	1	1-18028-2	WASHER, FLAT, REG M4		119
7	-	1	1	2119955-1	ASSY, LUBRICATOR, SIDE FEED		113
-	1	1	1	2844908-1	SCREW, LOCKING		99
-	1	1	1	2844907-1	POST, LOCKING		98
-	1	1	1	455888-4	SPACER, CRIMPER		82
-	1	1	1	1803607-3	DOCUMENTATION PACKAGE		71
-	1	1	1	2119740-1	TAG, IDENTIFICATION		67
-	2	2	2	2168078-1	SCREW, DRIVE, RH, RoHS, 2 x .188		66
-	1	1	1	5-18022-5	SCR, HEX HD CAP, M4 X 6.0		59
5	-	1	1	985575-3	SCR, FLT SKT HD CAP M3 X 10.0		57
-	1	1	1	1338685-1	PAWL, FEED		56
-	2	2	2	2168083-3	SCR, SKT HD CAP, RoHS, M4 X 12.0		53
8	-	-	1	18023-9	SCR, SKT HD CAP M4 X 6.0		49
-	-	-	1	2119652-1	FEED CAM, PRE FEED		48
-	1	1	1	1803602-1	SCR, BHSC, RoHS (M8 X 25)		41
-	1	1	1	1752356-6	SUPPORT, TERMINAL		34
-	2	2	2	2079383-5	SCR, BHSC, RoHS (M4 X 20)		33
-	2	2	2	3-2844962-0	SPACER, CYLINDRICAL, STRIP GUIDE		30
-	1	1	1	2844992-1	ASSEMBLY, STRIP GUIDE		29
-	1	1	1	1-455888-0	SPACER, CRIMPER		28
-	1	1	1	1320928-2	STRIP GUIDE		24
-	1	1	1	2168083-2	SCR, SKT HD CAP, RoHS, M4 X 8.0		21
-	1	1	1	1-18028-2	WASHER, FLAT, REG M4		20
-	1	1	1	2119533-1	STRIPPER, SIDE FEED		19
1	-	1	1	2119806-1	INSERT, SHEAR		13
-	1	1	1	3-22280-3	SPRING, COMPRESSION		12
-	1	1	1	1-356885-4	STOP, SHEAR		11
1	-	1	1	2119805-1	SHEAR HOLDER, FRONT		10
1	-	1	1	318707-1	FLOATING SHEAR, FRONT		9
1	1	1	1	1333332-2	ANVIL, COMBINATION, SPECIAL		8
-	1	1	1	2-240641-1	SPACER		7
-	-	-	-	-	-		6
-	1	1	1	2119781-1	DEPRESSOR, SHEAR		5
-	1	1	1	238011-4	BLOCK, CRIMPER SPACER		4
1	1	1	1	2-1633996-7	CRIMPER, INSULATION SPECIAL		3
-	1	1	1	1-455888-3	SPACER, CRIMPER		2
1	1	1	1	1-456403-5	CRIMPER, WIRE PREMIUM		1

DIMENSIONS:		TOLERANCES UNLESS OTHERWISE SPECIFIED:		DRAWING NO		DESCRIPTION		ITEM NO
mm	0 PLC ±	1 PLC ±	2 PLC ±	3 PLC ±	4 PLC ±	ANGLES ±	FINISH	
MATERIAL				WEIGHT	SCALE	SHEET	OF	REV
Customer Accessible Production Drawing				SCALE	1:2	SHEET	3	OF 4



Ocean Side Feed Applicator

LOC	DIST	REVISIONS					
A	66	P	LYN	DESCRIPTION	DATE	OWN	APVD
		-		SEE SHEET 1			

FEED TYPE MECHANICAL

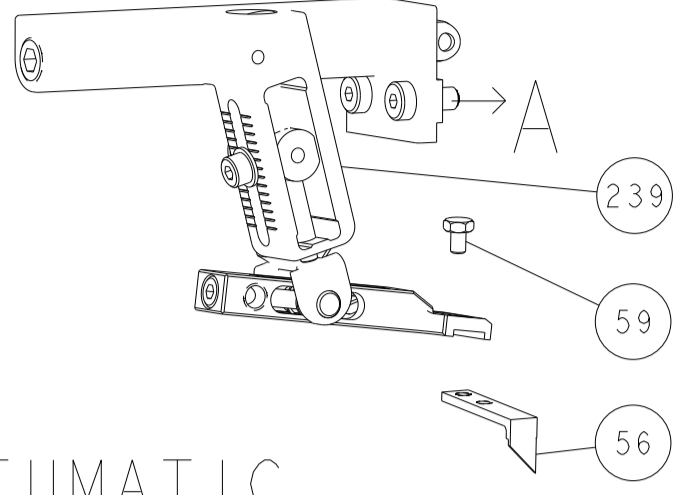

PNEUMATIC

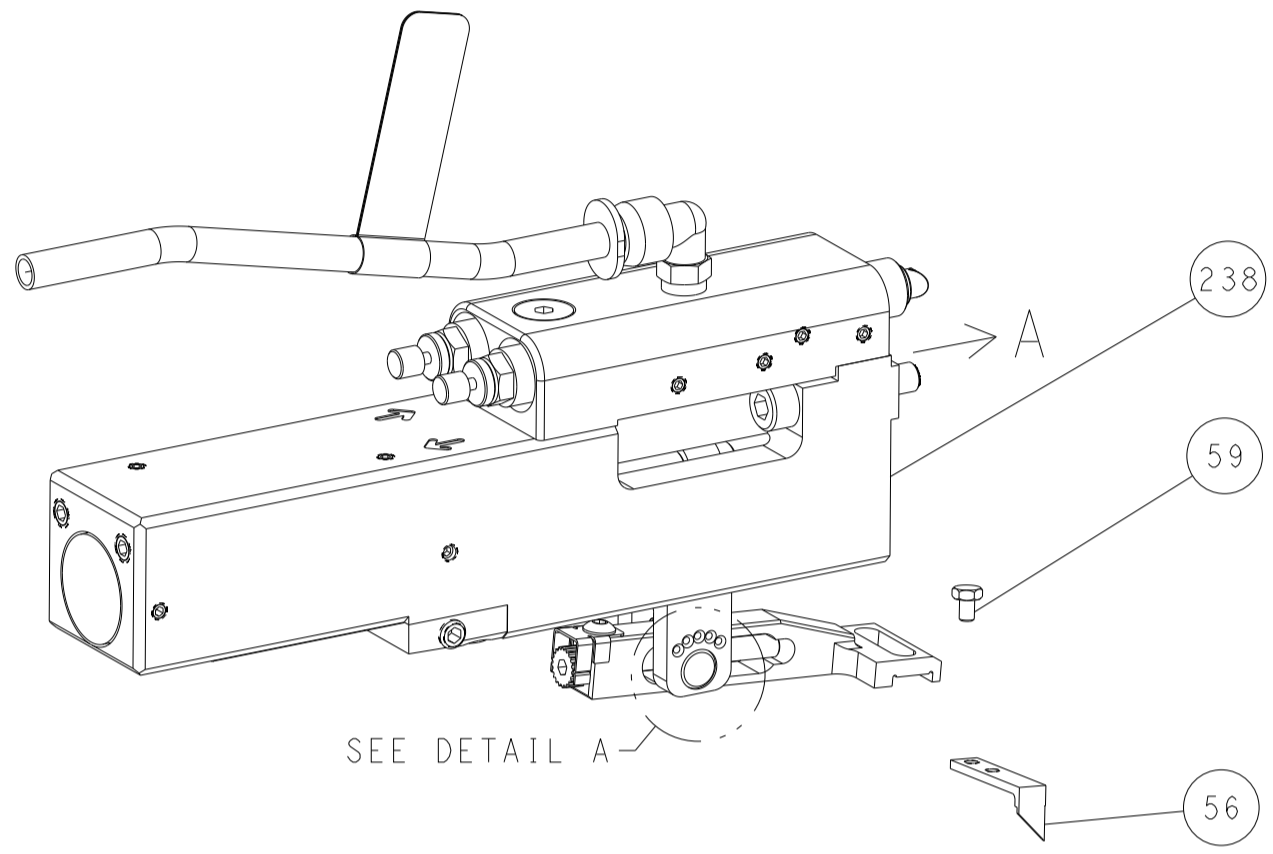

FEED SPRING SETTING POSITION
(SHOWN FROM REAR SIDE)

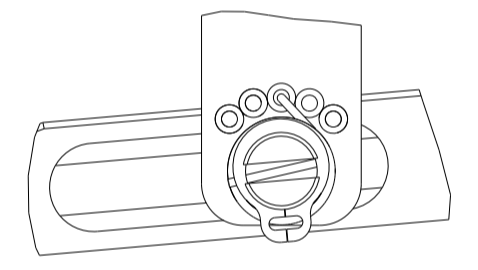

DETAIL A

DOUBLE ACTING PNEUMATIC WITH SENSORS

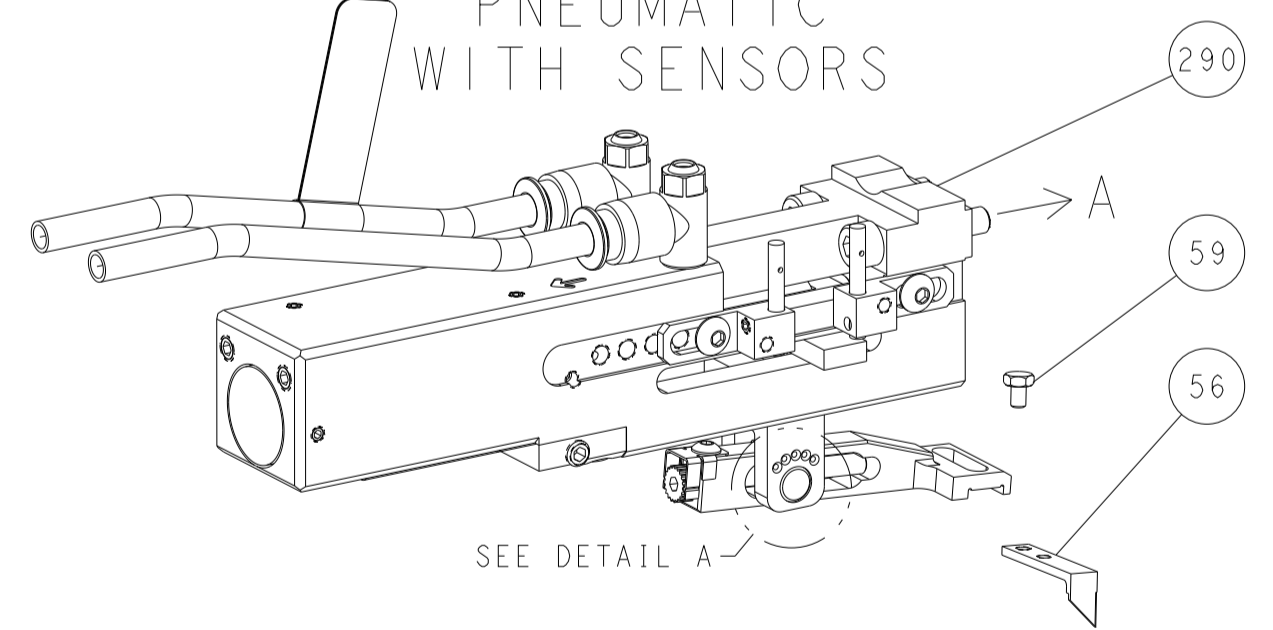

SEE DETAIL A

CAM POSITIONS

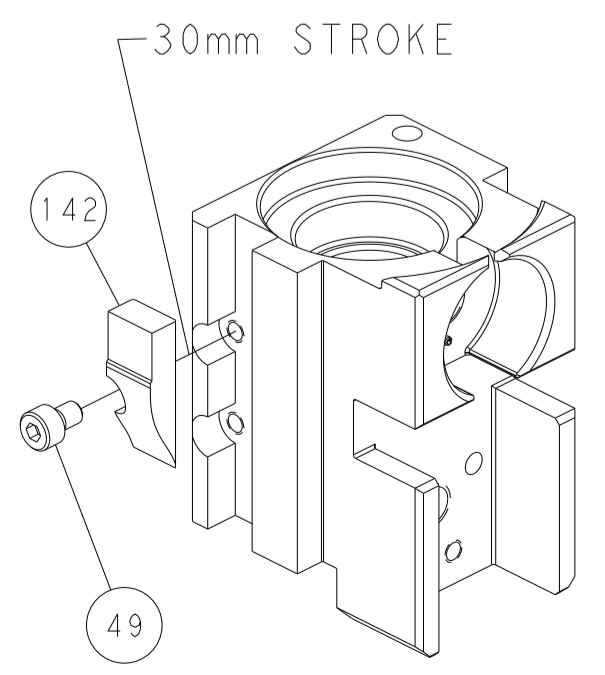

MECHANICAL
POST FEED

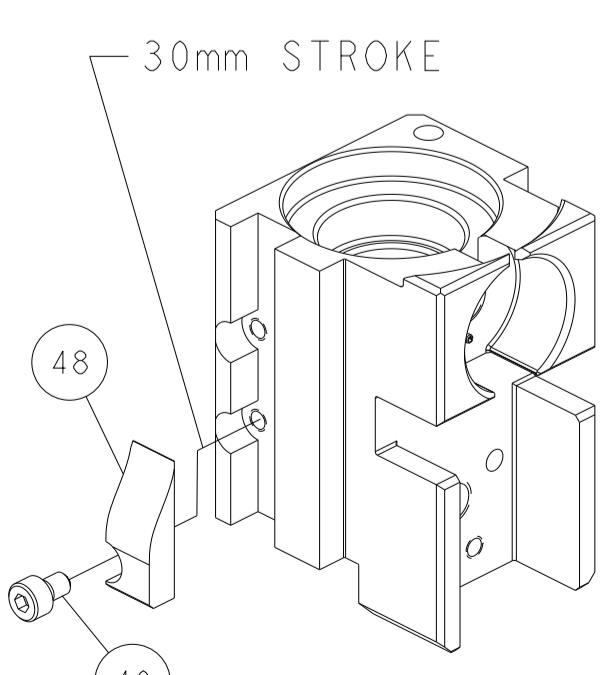

MECHANICAL
PRE FEED

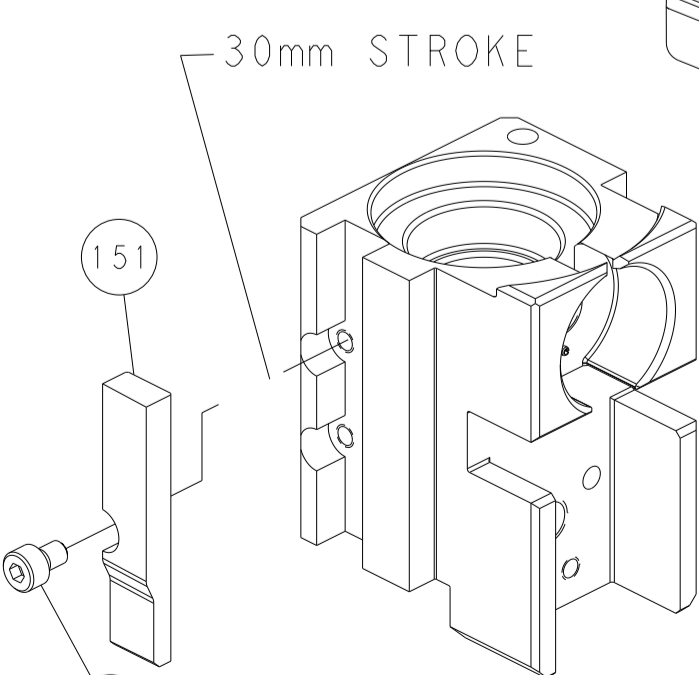

AIR FEED

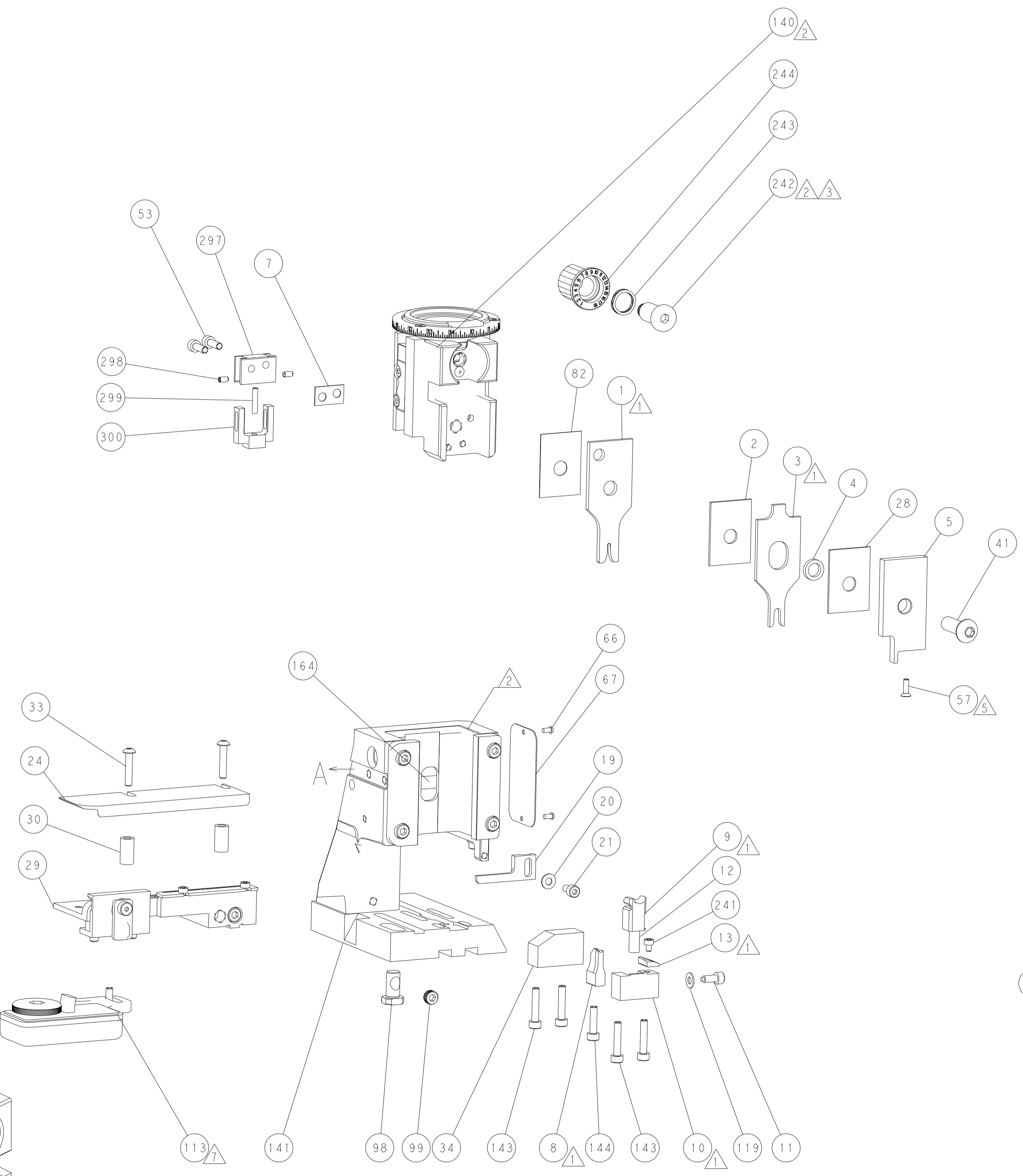

PACIFIC VERSION
 Shown on sheets 3 of 4 & 4 of 4
 (Atlantic version shown on sheets 1 of 4 & 2 of 4)

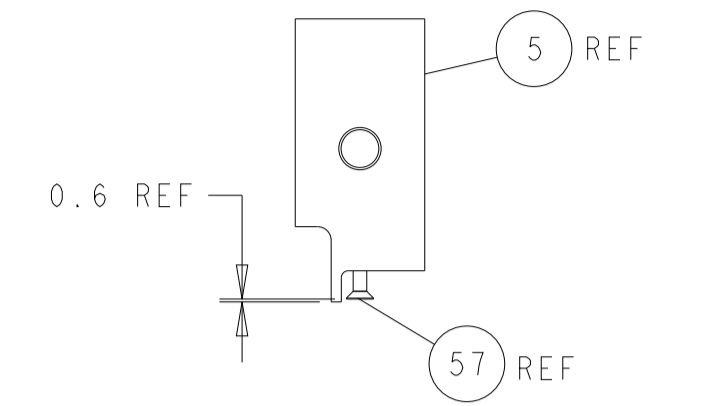

SHEAR DEPRESSOR DETAIL

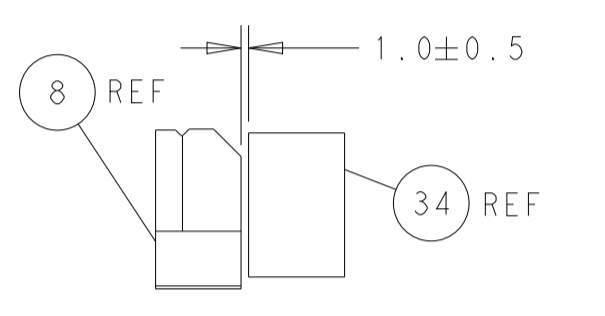

TERMINAL SUPPORT LOCATION

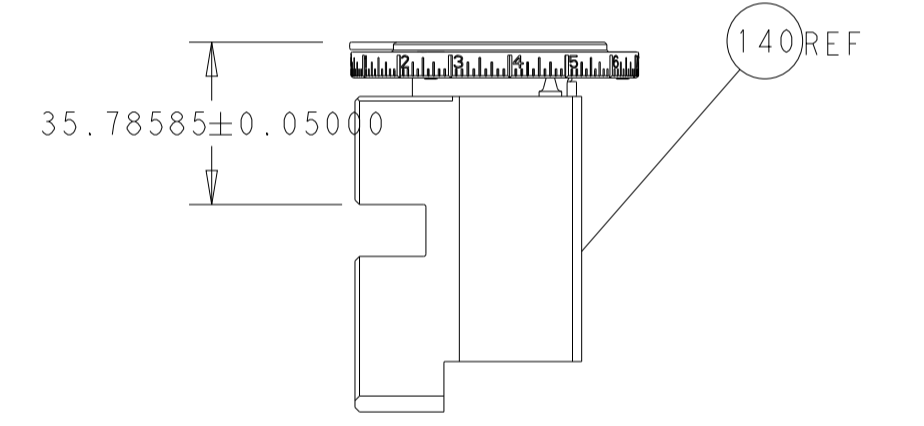

RAM SET-UP

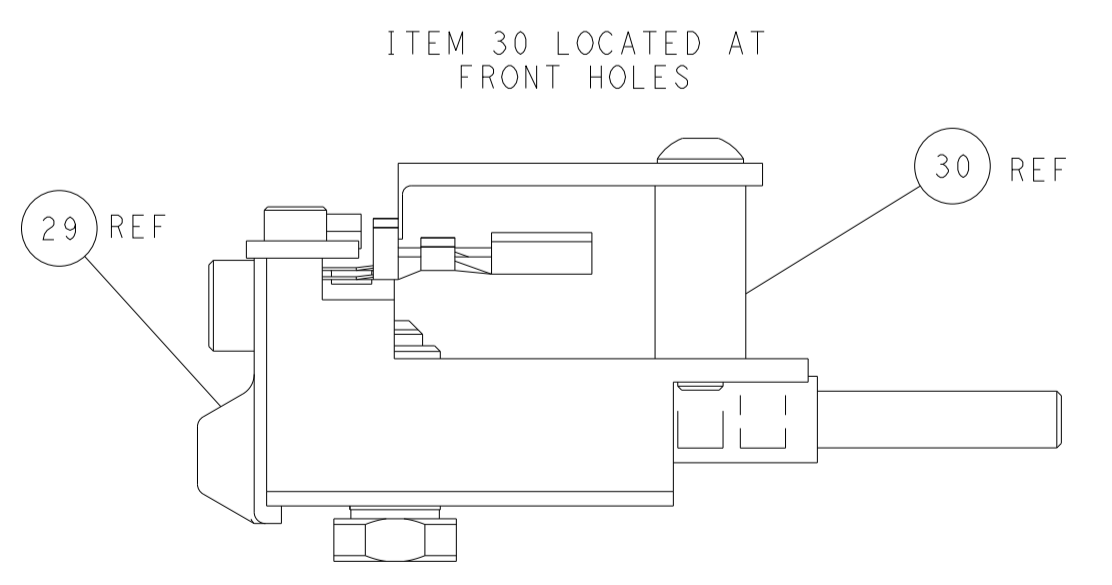

FEED TRACK POSITION
GUIDE BY INSULATION BARREL

<small>THIS DRAWING IS UNPUBLISHED. RELEASED FOR PUBLICATION. ALL RIGHTS RESERVED. © 2013 BY TYCO ELECTRONICS CORPORATION. THIS DRAWING IS CONTROLLED DOCUMENT. FOR THE LATEST REVISIONS, CONTACT THE DRAWING ENGINEER OR THE QUALITY ASSURANCE DEPARTMENT.</small>		DWN Y. YIN 14MAR2013 CHK G. BAILEY 14MAR2013 APVD U. GUO 14MAR2013	NAME Ocean Side Feed Applicator
DIMENSIONS: mm 	TOLERANCES UNLESS OTHERWISE SPECIFIED: 0 PLC ± 1 PLC ± 2 PLC ± 3 PLC ± 4 PLC ± ANGLES ± FINISH	PRODUCT SPEC APPLICATION SPEC WEIGHT SCALE 1:2	SIZE CAGE CODE DRAWING NO A1 00779 C=2151519 SHEET 4 OF 4 REV F