

PCB DRILLING DETAILS

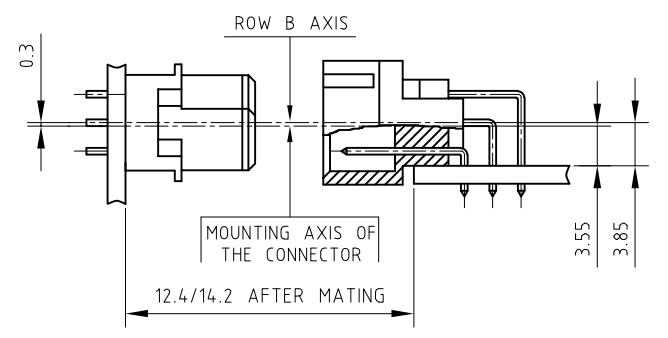
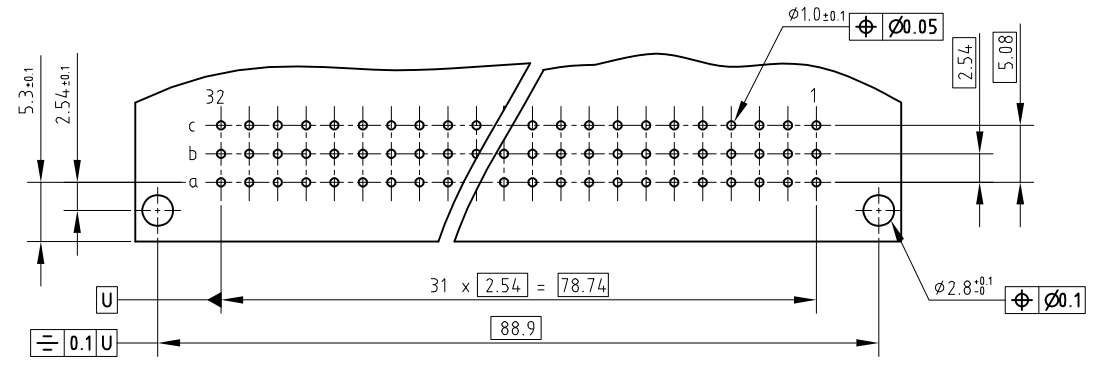

TECHNICAL SPECIFICATION

HOUSING MATERIAL : HIGH TEMPERATURE THERMOPLASTIC POLYESTER (LCP) UL94V-0, NATURAL
 HOUSING CAN WITHSTAND EXPOSURE TO 260°C PEAK TEMPERATURE FOR 30 SECONDS IN A CONVECTION, INFRARED OR VAPOUR REFLOW SOLDER APPLICATION

CONTACT / HARPOON MATERIAL : COPPER ALLOY

CONTACT ACTIVE ZONE PLATING : AU/GXT™ OVER NICKEL

CONTACT TERMINATION ZONE/HARPOON PLATING

LEAD FREE VERSION : TIN (PURE MATTE) OVER Ni

RAILWAY CLASSIFICATION : I2/F1 acc to NFF 16-101/102
 R22/R23 to HL3 acc to EN45545-2:2013

ELECTRICAL DATA

CURRENT RATING AT 20°C : 1.5 A

CURRENT (I MAX) : 2 A

TEMPERATURE RANGE : -55°C/+125°C

CONTACT RESISTANCE : ≤ 20mΩ

INSULATION RESISTANCE : ≥ 10⁸ MΩ

TEST VOLTAGE (rms) : 1000V

MECHANICAL DATA

INSERTION FORCE PER CONTACT : ≤ 0.94N

EXTRACTION FORCE PER CONTACT : ≥ 0.15N

REFERENCE SPECIFICATIONS : DIN 41612 / IEC 603-2

SERIES	8609	3	96	7	1	13	B	5	5	F1LF
ROWS FITTED WITH CONTACTS										
Rows a b c	3		96							
Rows a - c	4		64							
NUMBER OF CONTACTS										
TYPE OF INSULATOR										
3 ROW MALE INSULATOR	7									
METHOD OF MOUNTING										
STANDARD MOUNTING - STYLE C/2	1									
TERMINATION										
ANGLED SPILL	13									
OPTIONS										
HIGH TEMPERATURE HOUSING (NATURAL)										B
HIGH TEMPERATURE HOUSING (NATURAL) WITH HARPOONS										T
PERFORMANCE CLASS										
DIN 41612 CLASS 3										4
DIN 41612 CLASS 2										5
DIN 41612 CLASS 1										6
AS PER MIL C 55302/ JSS 50808										8
PITCH PER ROW										
2.54										5
SPECIAL CODE : F1LF	HIGH TEMPERATURE INSULATOR, LEADFREE VERSION									

NOTES:

- THE "LF" PRODUCTS MEET EUROPEAN UNION DIRECTIVES AND OTHER COUNTRY REGULATIONS AS DESCRIBED IN GS-47-0004.
- LEAD FREE OR RoHS DIRECTIVE LABELING TO BE PROVIDED AS PER GS-14-920 FOR LEAD FREE VERSION.
- FOR GENERAL CHARACTERISTICS AND RoHS INFORMATION, REFER DRAWING C-8609-0000A.

mat'l. code SEE TECH. SPEC.		surface ISO 1302 ✓		tolerance ISO 406 ISO 1101		projection mm		product family 8609	
ltr		ecn no		dr		date		title	
A				MJA		2016-11-29		DIN STANDARD HEADER	
B		ELX-I-40715		MJA		2021-04-20		ANGLED SPILL DIN 41612 STYLE-C (HIGH TEMPERATURE VERSION)	
								scale 3:2	
				dr		M JACOB		2016-11-29	
				enr		M JACOB		2016-11-29	
				chr		M JACOB		2021-04-20	
				appd		SAN0J		2021-04-20	
sheet index		revision sheet		B		1		Amphenol FCI	
								dwg no C-8609-2360	
								sheet 1 of 1	
								size A3	
								type Product Customer Drawing	