

LOC		DIST		REVISIONS			
P	LTN	DESCRIPTION	DATE	DWN	APVD		
A		RELEASED PER ECO 10-017541	8-25-10	CT	KT		
B		REVISED PER ECO-17-018523	19JAN2018	PHM	CT		

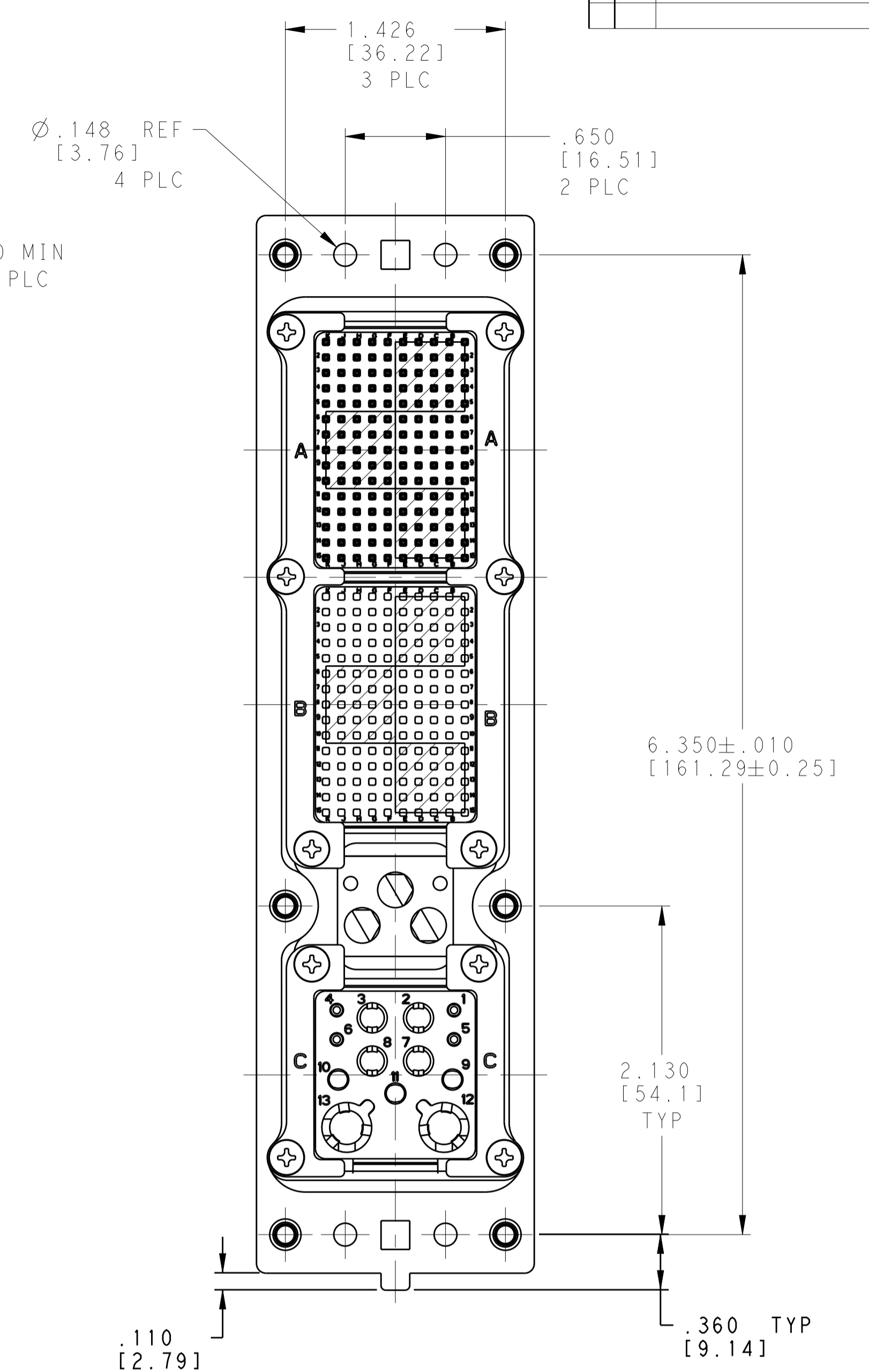
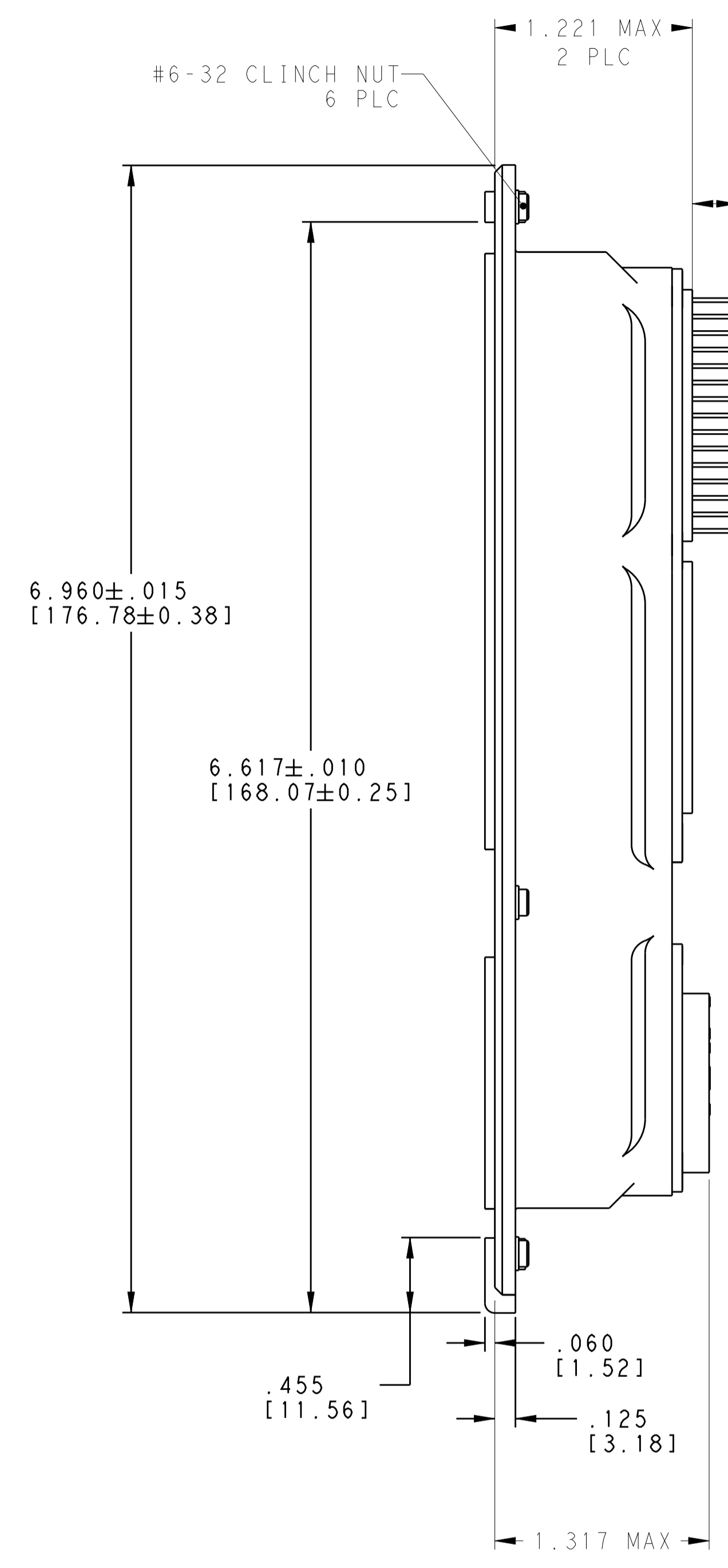
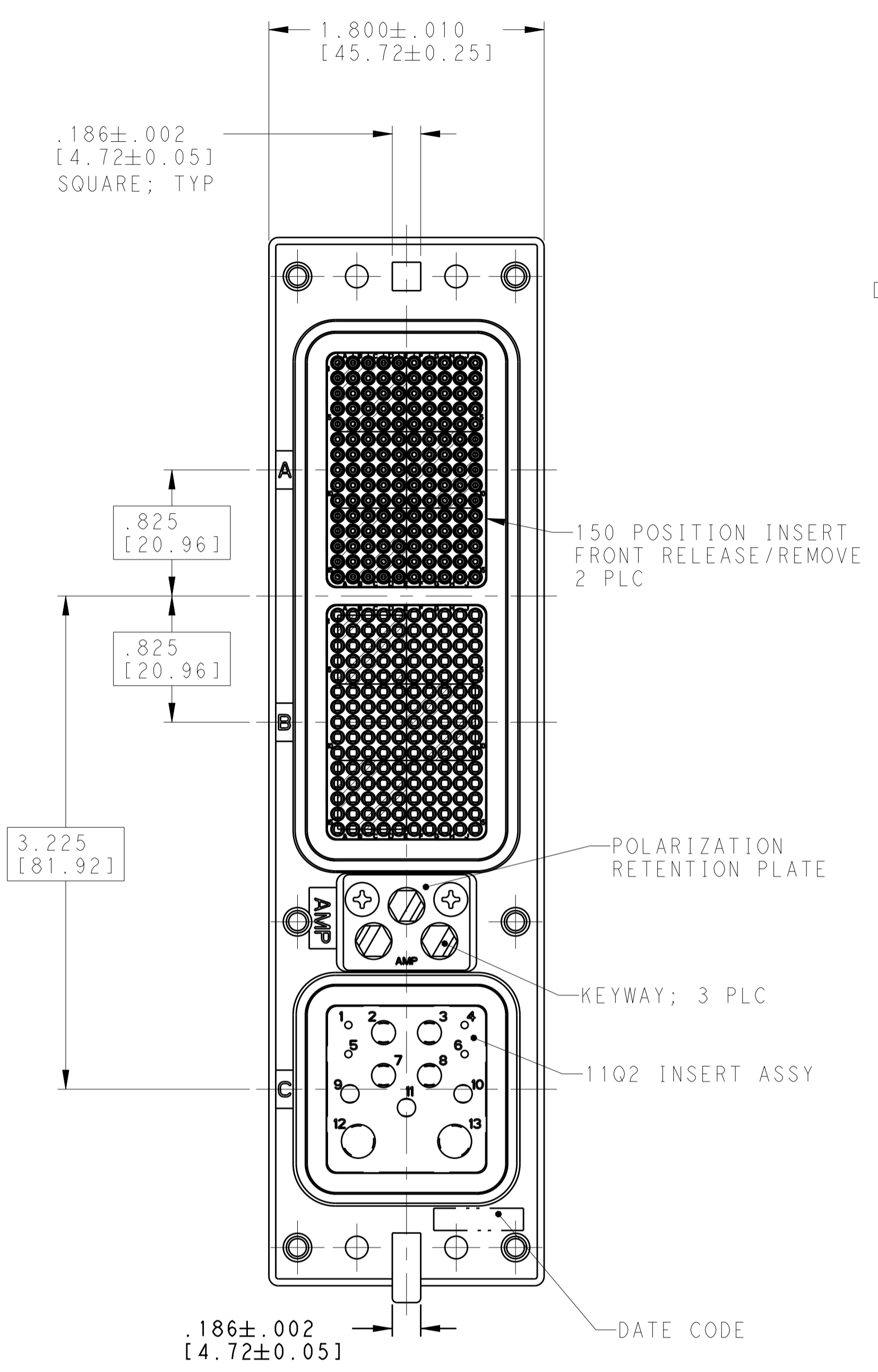

COMPONENT	MATERIAL	FINISH
FLAT HEAD SCREWS	STEEL OR STAINLESS STEEL	STAINLESS STEEL OR PASSIVATED
CLINCH NUT 6 PLC	STEEL	ZINC PLATED WITH YELLOW TRIVALENT CHROMATE
POLARIZATION KEYWAY 3 PLC	ZINC ALLOY PER ASTM-B-86	---
KEYWAY RETAINER PLATE	ALUMINUM ALLOY	BLUE ANODIZED PER MIL-A-8625
150 POSN. & 11Q2 INSERT ASSY	THERMOPLASTIC OR THERMOSET	---
SHELL AND RETENTION PLATES	ALUMINUM ALLOY PER ASTM-B-85	CHROMATE CONVERSION PER MIL-C-5541, TYPE II, CLASS 3.

- CONNECTOR MEETS ARINC 600 SPECIFICATIONS
- CONNECTOR IS SUPPLIED WITH CONTACTS AND FILLER PLUGS (PER TABLE).
- CONNECTOR IS SUPPLIED WITH A DUST COVER INSTALLED FOR SHIPPING.
- CONNECTOR IS SUPPLIED WITH KEYING ASSEMBLED PER TABLE.

"50"	MODULE A Tyco P/N 211431-4 (SIZE 22 POSTED SOCKET CONTACT; QTY=150) MODULE B NONE MODULE C Tyco P/N 1663767-6 (SIZE 20 FILLER PLUG; QTY=2) Tyco P/N 1663767-7 (SIZE 16 FILLER PLUG; QTY=3) Tyco P/N 1663767-8 (SIZE 12 FILLER PLUG; QTY=4) NO FILLER PLUGS IN CAVITY: 1, 4, 12 & 13	2101947-1
KEYING POSITION	CONTACTS AND FILLER PLUGS INCLUDED AND INSTALLED	PART NUMBER

DIMENSIONS: [INCHES][mm] 		TOLERANCES UNLESS OTHERWISE SPECIFIED: 0 PLC ± 1 PLC ± 3 PLC ±.005 (0.13) 4 PLC ± ANGLES ±		DWN C.C. THOMAS 5-17-10 CHK K. THACKSTON 5-17-10 APVD K. THACKSTON 5-17-10 PRODUCT SPEC APPLICATION SPEC		Tyco Electronics Harrisburg, PA 17105-3608	
MATERIAL SEE TABLE		FINISH SEE TABLE		WEIGHT		NAME: RECEPTACLE ASSY, SIZE 2, ARINC 600 (150/150/11Q2) SIZE: CAGE CODE DRAWING NO: A100779C=2101947 RESTRICTED TO:	
CUSTOMER DRAWING				SCALE 3:2		SHEET 1 OF 1 REV B	