

# Full-Time Continuous Monitor Installation, Operation and Maintenance



Made in the  
United States of America



Figure 1. Desco Full-Time Continuous Monitor

## Description

The Desco Full-Time Continuous Monitor is a single workstation continuous monitor. It continuously monitors the wiring of an AC outlet, path-to-ground integrity of one operator, and the ground plane of one ESD worksurface. Mounting tabs make it suitable to install in workbench or equipment settings. The embedded relay terminal activates when a pass condition is displayed on the monitor and can be connected to machines for access control or other devices. Connect the 19323 Power Relay accessory to control power to workbenches, hand tools, and other electronic devices dependent on the Full-Time Continuous Monitor's status.

The Full-Time Continuous Monitor is designed with Wave Distortion Technology to provide stable continuous monitoring of the path-to-ground and presence of 1 megohm resistance of an operator's wrist strap. Audio and visual alarms activate (in less than 500 milliseconds) when the operator unintentionally disconnects from the monitor or the wrist strap connection points are intermittent. The Full-Time Continuous Monitor also monitors for a worksurface path-to-ground of less than 10 megohms and the integrity of the electrical ground used to by the monitor. All Full-Time Continuous Monitors are calibrated to NIST standards and include a certificate.

## WAVE DISTORTION

**Wave Distortion Technology is the Most Reliable Technology for the Continuous Monitoring of Single-Wire (Conductor) Wrist Straps**

"Wave Distortion" or vector impedance works by applying a continuous test voltage of 1.2 volts peak-to-peak at 1 to 2 microamperes (0.000002 amperes) to the wrist strap that is connected to the continuous or constant monitor. The test voltage creates a square wave that the monitor circuit compares to established patterns. By monitoring the "distortions", or shape of the square wave, Wave Distortion Technology determines if the monitored circuit is complete - the operator is in the circuit and the total equivalent DC resistance is within specifications. Wave Distortion Technology produces a very fast alarm time and minimal false alarms.

ANSI/ESD S20.20 section 7.3 states "Compliance verification records shall be established and maintained to provide evidence of conformity to the technical requirements." Per ANSI/ESD S1.1 Annex A.3 Daily (wrist strap system) testing may be omitted if constant monitoring used." Per ESD Handbook ESD TR 20.20 section 5.3.2.4.4 "Typical Test programs recommend that wrist straps that are used daily should be tested daily. However, if the products that are being produced are of such value that knowledge of a continuous, reliable ground is needed, and then continuous monitoring should be considered or even required."

The Full-Time Continuous Monitor and its accessories are available as the following item numbers:

Item	Description
<a href="#">19321</a>	Full-Time Continuous Monitor, with North America Power Cord
<a href="#">19322</a>	Full-Time Continuous Monitor, with UK Power Cord
<a href="#">19323</a>	Power Relay, North America
<a href="#">19327</a>	Power Cord, North America
<a href="#">19328</a>	Power Cord, UK
<a href="#">98221</a>	Wave Distortion Monitor Verification Tester

## Packaging

### 19321 Full-Time Continuous Monitor

- 1 Full-Time Continuous Monitor
- 1 Mat Monitor Cord (White)
- 1 Countersunk Washer
- 1 Flat Head Screw, 6-32 x 1/4"
- 2 Pan-Head Screws, #6 x 3/8"
- 1 Dual Lock Fastener Set, 2" Length
- 1 Power Cord with North American Plug
- 1 Certificate of Calibration

### 19322 Full-Time Continuous Monitor

- 1 Full-Time Continuous Monitor
- 1 Mat Monitor Cord (White)
- 1 Countersunk Washer
- 1 Flat Head Screw, 6-32 x 1/4"
- 2 Pan-Head Screws, #6 x 3/8"
- 1 Dual Lock Fastener Set, 2" Length
- 1 10mm Interchangeable Park Snap
- 1 10mm Operator Jack Adapter
- 1 Power Cord with UK Plug
- 1 Certificate of Calibration

### 19323 Remote Alarm

- 1 Power Relay
- 1 Interface Cable
- 1 Power Cord with North American Plug



Figure 2. Desco 19321 Full-Time Continuous Monitor packaging contents



Figure 3. Desco 19322 Full-Time Continuous Monitor packaging contents



Figure 4. Desco 19323 Power Relay packaging contents

# Features and Components

## Full-Time Continuous Monitor



Figure 5. Full-Time Continuous Monitor features and components

**A. Park Snap:** Allows the operator to disconnect (and park) a wrist strap when leaving the workstation, without creating a false alarm. Touch the park snap or park switch, and the monitor's audible alarm will disable for approximately 8 seconds. Use this time to disconnect the wrist cord from the wristband, and attach it to the park snap or remove the banana plug from the jack. Upon returning to the workstation and disconnecting the wrist cord from the park snap, the operator has approximately 8 seconds to reconnect the wrist cord to a worn wristband before activating the alarm.

**B. Monitored Operator Jack:** Insert the single-wire wrist cord here to monitor the operator's connection to ground.

**C. Operator LEDs:** Illuminates green when the operator is properly grounded. Illuminates solid red and audible alarm sounds when the operator is not properly grounded.

**D. Mat LEDs:** Illuminates green when the worksurface is properly grounded. Illuminates red and audible alarm sounds when the worksurface is not properly grounded.

**E. Ground LEDs:** Illuminates green when the AC outlet is properly wired and its path to equipment ground via the equipment ground conductor is intact. Illuminates red and audible alarm sounds when the AC outlet is not properly wired and its path to equipment ground via the equipment ground conductor is broken.

**F. Park Switch:** Allows the operator to disconnect (and park) a wrist strap when leaving the workstation, without creating a false alarm. Touch the park snap or park switch, and the monitor's audible alarm will disable for approximately 8 seconds. Use this time to disconnect the wrist cord from the wristband, and attach it to the park snap or remove the banana plug from the jack. Upon returning to the workstation and disconnecting the wrist cord from the park snap, the operator has approximately 8 seconds to reconnect the wrist cord to a worn wristband before activating the alarm. The 8 second timer is indicated by the growing intensity of the park switch's blue LED. The blue LED will pulse when the operator jack is vacant to indicate standby mode.

**G. Power Inlet:** Connect the included power cord here.

**H. Mat Monitor Screw Terminal:** Verifies that the worksurface's path-to-ground is less than 10 megohms. Connect the white mat monitor cord here.

**I. Set Switch:** Toggles the monitor's settings for the audible alarm and mat monitor circuit.

Function	Procedure
Audible Alarm Volume	<ol style="list-style-type: none"> <li>1. Push and release the switch to toggle the buzzer's volume.</li> <li>2. The volume will toggle from low, medium, and high settings.</li> </ol>
Enable / Disable Mat Monitor Circuit	<ol style="list-style-type: none"> <li>1. Push and hold the switch until all LEDs illuminate orange.</li> <li>2. Release the switch.</li> <li>3. An illuminated MAT LED indicates that the mat monitor circuit is enabled. A non-illuminated MAT LED indicates that the mat monitor circuit is disabled.</li> </ol>

**J. Relay Terminal:** Integrates with electronic locks, lights, buzzers, etc. See the "Relay Terminal" section for more information.

**K. Accessory Jack:** Connects to the 19323 Power Relay accessory.

## Power Relay



Figure 6. Power Relay features and components

- A. Normally On Receptacle:** Provides power unless the operator is connected to the Full-Time Continuous Monitor, and it reports all PASS conditions.
- B. Always On Receptacle:** Always provides power regardless of the Full-Time Continuous Monitor's status.
- C. Switch Active LED:** Illuminates green when the internal relay switch is activated.
- D. Interface Connector:** Use the included interface cable to connect the Full-Time Continuous Monitor to this connector.
- E. Normally Off Receptacles:** Provides power when the operator is connected to the Full-Time Continuous Monitor, and it does not report any alarm conditions.
- F. Power Switch:** Rock to RESET to turn on the Power Relay. Rock to OFF to turn off the Power Relay.
- G. Power LED:** Illuminates red when the Power Relay is powered.
- H. Power Inlet:** Connect the included power cord here.

## Installation

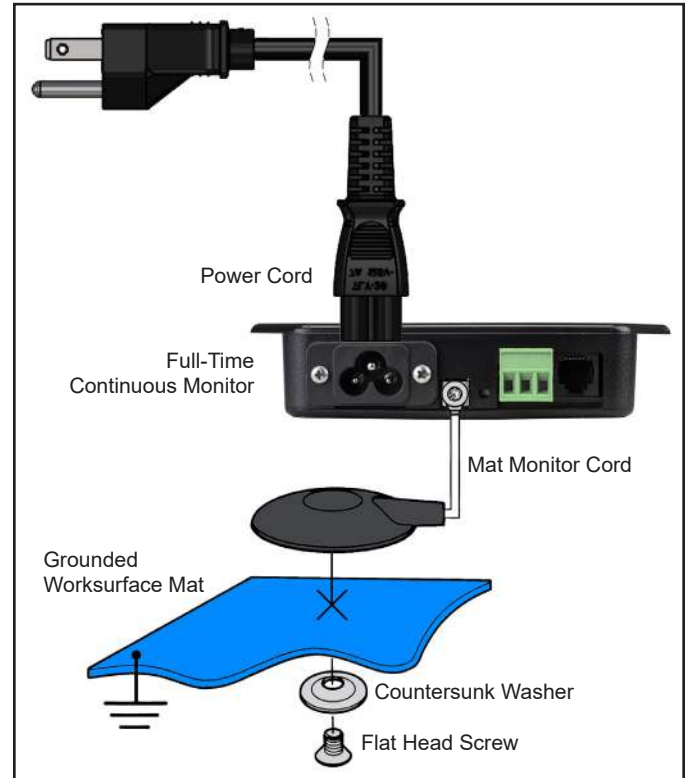

Figure 7. Installing the Full-Time Continuous Monitor

1. Remove the Full-Time Continuous Monitor from the carton, and inspect for damage.
2. Determine the mounting location of the Full-Time Continuous Monitor. Its LEDs should be visible to the operator. Secure the Full-Time Continuous Monitor to a surface using its mounting tabs and the included pan head screws or dual lock fasteners.
3. Secure the ring termination of the white mat monitor cord to the mat monitor screw terminal on the back of the Full-Time Continuous Monitor.
4. Connect the mat monitor cord from the back of the Full-Time Continuous Monitor to a grounded worksurface mat. Use the included countersunk washer and flat head screw to secure the cord to the grounded mat.
5. Connect the power cord to the power inlet located on the back of the Full-Time Continuous Monitor. Connect the opposite end to an appropriate AC outlet.

## Power Relay



Figure 8. Desco 19323 Power Relay



Figure 9. Installing the Power Relay

Pair the 19321 Full-Time Continuous Monitor with the Power Relay to control power to workbenches, hand tools, and other electronic devices dependent on the monitor's status.

1. Determine the mounting location of the Power Relay. Locate it within reach of its included power cord. The Power Relay's mounting tabs may be to secure it onto a surface.
2. Connect the included power cord to the power inlet located on the side of the Power Relay. Connect the opposite end to an appropriate AC outlet.

**NOTE: The Power Relay is only rated to accept 90-120 VAC input voltage.**

3. Connect the included interface cable to the back of the Full-Time Continuous Monitor. Connect the opposite end to the green connector on the side of the Power Relay.
4. Connect the power cord from the Full-Time Monitor to the Always ON receptacle on the Power Relay.
5. Connect the power cord of the external electronic device to one of the Normally OFF receptacles on the Power Relay.
6. Toggle the power switch to the RESET position. Both the Full-Time Continuous Monitor and the Power Relay will power on.
7. This setup will power the external electronic device whenever an operator connects to the Full-Time Continuous Monitor and no alarms are reported.



Figure 10. Using the Power Relay

## Relay Terminal

The Full-Time Continuous Monitor features a relay terminal that can be integrated with electronic locks, lights, buzzers, etc. The relay will activate when a failure is reported by the Full-Time Continuous Monitor.

Contact Form	2 Form C
Maximum Switching Power	60 W, 125 VAC
Maximum Switching Voltage	220 VDC, 250 VAC
Maximum Switching Current	2 A
Maximum Carrying Current	2 A

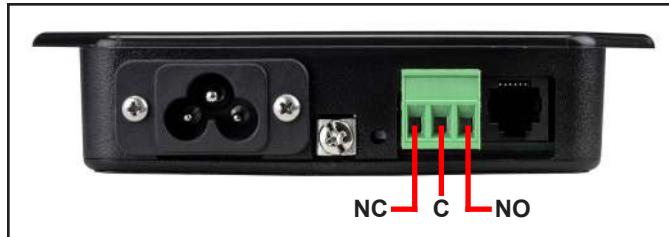

Figure 11. Relay terminal contacts

## 10 mm Snap Adapters

The 19322 Full-Time Continuous Monitor includes an interchangeable 10 mm park snap and 10 mm banana jack adapter for operators who use wrist cords with 10 mm terminations. Use the park snap's knurled rim to unscrew the 4 mm park snap from the monitor and install the 10 mm park snap to the monitor. Plug the 10 mm operator jack adapter into the monitor's operator jack.



Figure 12. Installing the 10 mm snap adapters to the 19322 Full-Time Continuous Monitor

## Operation

1. Fit the wristband snugly onto the wrist.
2. Snap the wrist cord to the wristband.
3. Plug the wrist cord into the operator jack. The green operator LED will illuminate. This indicates that the operator is properly grounded.
4. If this does not happen, examine the wrist cord for continuity or damage and the wristband to ensure that it fits securely. If you have dry skin, apply an approved dissipative hand lotion such as [Menda Reztore® ESD Hand Lotion](#).
5. When leaving the workstation, first touch the monitor's park switch or park snap. The monitor's audible alarm will disable for approximately 8 seconds. Use this time to disconnect the wrist cord from the wristband and attach it to the park snap without sounding a false alarm.
6. Upon returning to the workstation and disconnecting the wrist cord from the park snap, the monitor will provide approximately 8 seconds for the operator to reconnect the wrist cord to a worn wristband before sounding the monitor's alarm.



Figure 13. Using the Full-Time Continuous Monitor when mounted underneath a workbench tabletop



Figure 14. Using the Full-Time Continuous Monitor when mounted on a workbench upright



Figure 15. Using the Full-Time Continuous Monitor at a machine station

## Calibration

Frequency of recalibration should be based on the critical nature of those ESD sensitive items handled and the risk of failure for the ESD protective equipment and materials. In general, Desco recommends that calibration be performed annually.

Use the Desco 98221 Wave Distortion Monitor Verification Tester to perform periodic verification (once every 6-12 months) of the Full-Time Continuous Monitor. The verification tester can be used to check the test limits of the Full-Time Continuous Monitor without removing it from the workstation.

See [TB-3074](#) for more information.



Figure 16. Desco 98221 Wave Distortion Monitor Verification Tester

# Specifications

## Full-Time Continuous Monitor

Input Voltage and Frequency	Power Input: 100-240 VAC, 50/60 Hz  Power Cord Length: 6 ft. (1.8 m)
Operating Temperature	50 to 95° F (10 to 35° C)
Environmental Requirements	Indoor use only at altitudes less than 6500 ft. (2 km)  Maximum relative humidity of 80% up to 85° F (30° C) decreasing linearly to 50% @ 85° F (30° C)
Dimensions	2.85" L x 5.13" W x 1.00" H (72 mm x 130 mm x 25 mm)
Weight	0.35 lbs. (0.16 kg)
Operator Test Range*	500 kilohms to 10 megohms impedance
Worksurface Test Limit**	10 megohms (±20%)
Operator Test Voltage	1.2 V peak-to-peak @ 1.2 µA, open circuit
Worksurface Test Voltage	5 to 7.5 V, open circuit
Alarm Response Time	<500 ms
Country of Origin	United States of America

\*This cannot be verified with standard DC test equipment. The continuous monitor is an impedance sensing device, and the limits are determined by the magnitude and angle of the impedance.

\*\*The worksurface mat must have a conductive layer such as Dual Layer Rubber or Dissipative 3-Layer Vinyl with conductive buried layers. Desco workstation monitors are not recommended for use with homogeneous matting.

ANSI/ESD S20.20 requires the use of a surface resistance meter for periodic verification of a worksurface's resistance-to-ground (Rtg). Constant monitors may not be used as a substitute for this requirement.

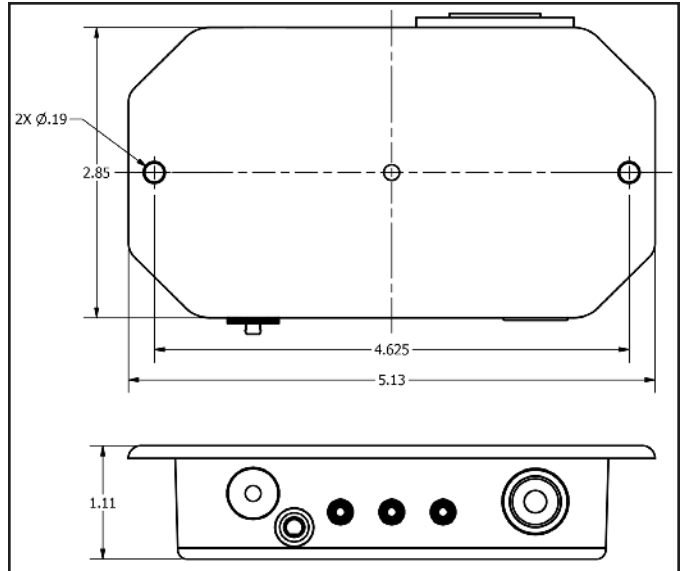

Figure 17. Mounting hole locations on the Full-Time Continuous Monitor (all dimensions are in inches)

## Power Relay

Input Voltage and Frequency	90-120 VAC, 50/60 Hz
Output Voltage	90-140 VAC
Max Load	12 A
Input Connector	C-13/C-14
Output Connector	4x NEMA 5-15
Outlet Types	2x Normally OFF 1x Normally ON 1x Always ON
Dimensions	6.7" L x 3.7" W x 1.4" H (170 mm x 95 mm x 35 mm)
Weight	0.7 lbs. (0.32 kg)
Power Cord Length	1.5 ft. (0.5 m)
Interface Cable Length	7 ft. (2.1 m)
Operating Temperature	-35 to 145° F (-37 to 63° C)
Environmental Requirements	5 to 95% RH non-condensing Indoor use only
Country of Origin	China

### Limited Warranty, Warranty Exclusions, Limit of Liability and RMA Request Instructions

See the Desco Warranty - [Desco.com/Limited-Warranty.aspx](http://Desco.com/Limited-Warranty.aspx)