

Demonstration System EPC9508 Quick Start Guide

*Amplifier Board for 6.78 MHz, ZVS
Class-D Wireless System using EPC8009/EPC2007*



DESCRIPTION

The EPC9508 is a high efficiency, Zero Voltage Switching (ZVS), Class-D wireless power amplifier demonstration board operating at 6.78 MHz (Lowest ISM band). The purpose of this demonstration system is to simplify the evaluation process of wireless power technology using eGaN® FETs by including all the critical components on a single board that can be easily connected into an existing system.

The EPC9508 amplifier board features the EPC8009 and EPC2007 enhancement mode field effect transistor (FET) in an optional half-bridge topology (single ended configuration) or default full-bridge topology (differential configuration), and includes the gate driver/s and oscillator that ensures operation of the system at 6.78 MHz. The amplifier board can also be operated using an external oscillator.

The amplifier board is equipped with a pre-regulator that limits the current of the supply to the amplifier. As the amplifier draws more current, which can be due to the absence of a device coil, the preregulator will reduce the voltage being supplied to the amplifier that will ensure a safe operating point. The pre-regulator also monitors the temperature of the main amplifier FETs and will reduce current if the temperature exceeds 85°C. The pre-regulator can be bypassed to allow testing with custom control hardware. The board further allows easy access to critical measurement nodes that allow accurate power measurement instrumentation hookup. A simplified diagram of the amplifier board is given in Figure 1.

For more information on the EPC8009 & EPC2007 eGaN FET please refer to the datasheet available from EPC at www.epc-co.com. The datasheet should be read in conjunction with this quick start guide.

Table 1: Performance Summary (T_A = 25°C) EPC9508

Symbol	Parameter	Conditions	Min	Max	Units
V _{DD}	Control Supply Input Range		7	12	V
V _{IN}	Bus Input Voltage Range – Pre-Regulator mode		8	32	V
V _{IN}	Bus Input Voltage Range – Bypass mode		0	32	V
V _{OUT}	Switch Node Output Voltage			V _{IN}	V
I _{OUT}	Switch Node Output Current (each)			10*	A
V _{extosc}	External Oscillator Input Threshold	Input 'Low'	-0.3	0.8	V
		Input 'High'	2.4	5	V
V _{Pre_Disable}	Pre-regulator Disable Voltage Range	Open Drain/Collector	-0.3	5.5	V
I _{Pre_Disable}	Pre-regulator Disable Current	Open Drain/Collector	-1	1	mA
V _{Osc_Disable}	Oscillator Disable Voltage Range	Open Drain/Collector	-0.3	5	V
I _{Osc_Disable}	Oscillator Disable Current	Open Drain/Collector	-25	25	mA

* Assumes inductive load, maximum current depends on die temperature – actual maximum current with be subject to switching frequency, bus voltage and thermals.



EPC9508 Amplifier Board Photo

DETAILED DESCRIPTION

The Amplifier Board (EPC9508)

Figure 1 shows a diagram of the EPC9508 ZVS class-D amplifier with pre-regulator. The pre-regulator is set to a specified current limit (up to 1.5 A) by adjusting P49 and operates from 6 V through 36 V input. The output voltage of the pre-regulator is limited to approximately 2 V below the input voltage. The pre-regulator can be bypassed by moving the jumper (JP60) over from the right 2 pins to the left 2 pins. To measure the current the amplifier is drawing, an ammeter can be inserted in place of the jumper (JP60) in the location based on the operating mode (pre-regulator or bypass).

The amplifier comes with its own oscillator that is pre-programmed to 6.78 MHz \pm 678 Hz. It can be disabled by placing a jumper into J70 or can be externally shutdown using an externally controlled open collector / drain transistor on the terminals of J70 (note which is the ground connection). The switch needs to be capable of sinking at least 25 mA. An external oscillator can be used instead of the internal oscillator when connected to J71 (note which is the ground connection) and the jumper (JP70) is moved from the right 2 pins to the left 2 pins.

The pre-regulator can also be disabled in the same manner as the oscillator using J51. The pre-regulator can be bypassed, to increase the operating voltage (with no current or thermal protection) to the amplifier or to use an external regulator, by moving the jumper JP60 from the right 2 pins to the left 2 pins. Jumper JP60 can also be used to connect an ammeter to measure the current drawn by the amplifier (make sure the ammeter connects to the pins that correspond to the mode of operation either bypass or pre-regulator).

Single Ended Operation

The amplifier can be configured for single ended operation where only devices Q1 and Q2 are used. In this mode only L_{ZVS1} and C_{ZVS} are used to establish ZVS operation. If Q11 and Q12 are populated, then the following changes need to be made to the board:

- 1) Remove R76 and R77
- 2) Short out C46 and C47
- 3) Short the connection of JMP1 (back side of the board)
- 4) Remove LZVS11
- 5) Check that CZVS1 is populated, if not then install.
- 6) R74 and R75 may need to be adjusted for the new operating condition to achieve maximum efficiency (see section on ZVS timing adjustment).

ZVS Timing Adjustment

Setting the correct time to establish ZVS transitions is critical to achieving high efficiency with the EPC9508 amplifier. This can be done by selecting the values for R74 and R75 respectively. This procedure is best performed using potentiometer P74 and P75 installed that is used to determine the fixed resistor values. The procedure is the same for both single ended and differential mode of operation. The timing MUST initial be set WITHOUT the source coil connected to the amplifier. The timing diagrams are given in Figure 4 and should be referenced when following this procedure. Only perform these steps if changes have been made to the board as it is shipped preset. The steps are:

1. With power off, connect the main input power supply bus to +V_{IN} (J50). Note the polarity of the supply connector.
2. With power off, connect the control input power supply bus to +V_{DD} (J90). Note the polarity of the supply connector.
3. Connect a LOW capacitance oscilloscope probe to the probe-hole J2 and lean against the ground post as shown in Figure 3.
4. Turn on the control supply – make sure the supply is between 7 V and 12 V range (7.5 V is recommended).
5. Turn on the main supply voltage to the required predominant operating value (such as 24 V but NEVER exceed the absolute maximum voltage of 36 V).
6. While observing the oscilloscope adjust P74 for the rising edge of the waveform so achieve the green waveform of figure 4. Repeat for the falling edge of the waveform by adjusting P75.
7. Check that the setting remains optimal with a source coil attached. In this case it is important that the source coil is TUNED to resonance WITH an applicable load. Theoretically the settings should remain unchanged. Adjust if necessary.
8. Replace the potentiometers with fixed value resistors.

Differential Operation

The amplifier can be configured for differential operation where all the devices are used; Q1, Q2, Q11 and Q12. In this mode either L_{ZVS1} , L_{ZVS11} and C_{ZVS} or L_{ZVS12} only is used to establish ZVS operation.

Determining Component Values for L_{ZVS}

The ZVS tank circuit is not operated at resonance, and only provides the necessary negative device current for self-commutation of the output voltage at turn off. The capacitance C_{ZVS} is chosen to have a very small ripple voltage component and is typically around 1 μ F. The amplifier supply voltage, switch-node transition time will determine the value of inductance for L_{ZVSx} which needs to be sufficient to maintain ZVS operation over the DC device load resistance range and coupling between the device and source coil range and can be calculated using the following equation:

$$L_{ZVS} = \frac{\Delta t_{vt}}{8 \cdot f_{sw} \cdot C_{OSSQ}} \quad (1)$$

Where:

Δt_{vt} = Voltage transition time [s]

f_{sw} = Operating frequency [Hz]

C_{OSSQ} = Charge equivalent device output capacitance [F].

Note that the amplifier supply voltage V_{AMP} is absent from the equation as it is accounted for by the voltage transition time. The charge equivalent capacitance can be determined using the following equation:

$$C_{OSSQ} = \frac{1}{V_{AMP}} \cdot \int_0^{V_{AMP}} C_{OSS}(v) \cdot dv \quad (2)$$

To add additional immunity margin for shifts in coil impedance, the value of L_{ZVS} can be decreased to increase the current at turn off of the devices (which will increase device losses). Typical voltage transition times range from 2 ns through 12 ns. For the differential case the voltage and charge (C_{OSSQ}) are doubled.

QUICK START PROCEDURE

The EPC9508 demonstration system is easy to set up and evaluate the performance of the eGaN FET in a wireless power transfer application.

The EPC9508 can be operated using any one of two alternative methods:

a. Using the pre-regulator

b. Bypassing the pre-regulator

a. Operation using the pre-regulator

The pre-regulator is used to supply power to the amplifier in this mode and will limit the current based on the setting. The pre-regulator also monitors the temperature of the amplifier and will limit the current in the event the temperature exceeds 85°C.

1. Make sure the entire system is fully assembled prior to making electrical connections and make sure jumper (JP60 is set to pre-regulator – right 2 pins).
2. With power **off**, connect the **main** input power supply bus to +V_{IN} (J50). Note the polarity of the supply connector.
3. With power **off**, connect the **control** input power supply bus to +V_{DD} (J90). Note the polarity of the supply connector.
4. Select and connect an applicable load resistance to the device board.
5. Make sure all instrumentation is connected to the system.
6. Turn on the control supply – make sure the supply is between 7 V and 12 V (7.5 V is recommended).
7. Turn on the main supply voltage to the required value (it is recommended to start at 8 V and do not exceed the absolute maximum voltage of 36 V).
8. Once operation has been confirmed, adjust the main supply voltage within the operating range and observe the output voltage, efficiency and other parameters on both the amplifier and device boards.
9. For shutdown, please follow steps in the reverse order. Start by reducing the main supply voltage to 0 V followed by steps 6 through 2.

b. Operation bypassing the pre-regulator

In this mode, the pre-regulator is bypassed and the main power is connected directly to the amplifier. This allows the amplifier to be operated using an external regulator or to test at higher voltages.

In this mode there is no current or thermal protection for the eGaN FETs.

1. Make sure the entire system is fully assembled prior to making electrical connections and remove the jumper JP60. Never connect the main power positive (+) to J50 when operating in bypass mode.
2. With power **off**, connect the **main** input power supply ground to the ground terminal of J50 (-) and the positive (+) to the **left-side** pin of JP60.

3. With power **off**, connect the **control** input power supply bus to +V_{DD} (J90). Note the polarity of the supply connector.
4. Select and connect an applicable load resistance to the device board.
5. Make sure all instrumentation is connected to the system.
6. Turn on the control supply – make sure the supply is between 7 V and 12 V range (7.5 V is recommended).
7. Turn on the main supply voltage to the required value (it is recommended to start at 2 V and do not exceed the absolute maximum voltage of 52 V).
8. Once operation has been confirmed, adjust the main supply voltage within the operating range and observe the output voltage, efficiency and other parameters on both the amplifier and device boards. See Pre-Cautions when operating in the bypass mode
9. For shutdown, please follow steps in the reverse order. Start by reducing the main supply voltage to 0 V followed by steps 6 through 2.

NOTE. When measuring the high frequency content switch-node (Source Coil Voltage), care must be taken to avoid long ground leads. An oscilloscope probe connection (preferred method) has been built into the board to simplify the measurement of the Source Coil Voltage (J2 and J3 as shown in Figure 4).

THERMAL CONSIDERATIONS

The EPC9508 demonstration system showcases the EPC8009 eGaN FET in a wireless energy transfer application. Although the electrical performance surpasses that of traditional silicon devices, their relatively smaller size does magnify the thermal management requirements. The operator must observe the temperature of the gate driver and eGaN FETs to ensure that both are operating within the thermal limits as per the datasheets.

NOTE. The EPC9506 / EPC9507 demonstration system has limited current and thermal protection only when operating off the Pre-Regulator. When bypassing the pre-regulator there is no current or thermal protection on board and care must be exercised not to over-current or over-temperature the devices. Wide coil coupling and load range variations can lead to increased losses in the devices.

Pre-Cautions

The EPC9508 demonstration system has no controller or enhanced protections systems and therefore should be operated with caution. Some specific precautions are:

1. Please contact EPC at info@epc-co.com should the tuning of the coil be required to change to suit specific conditions so that it can be correctly adjusted for use with the ZVS Class-D amplifier.
2. There is no heat-sink on the devices and during experimental evaluation it is possible present conditions to the amplifier that may cause the devices to overheat. Always check operating conditions and monitor the temperature of the EPC devices using an IR camera.

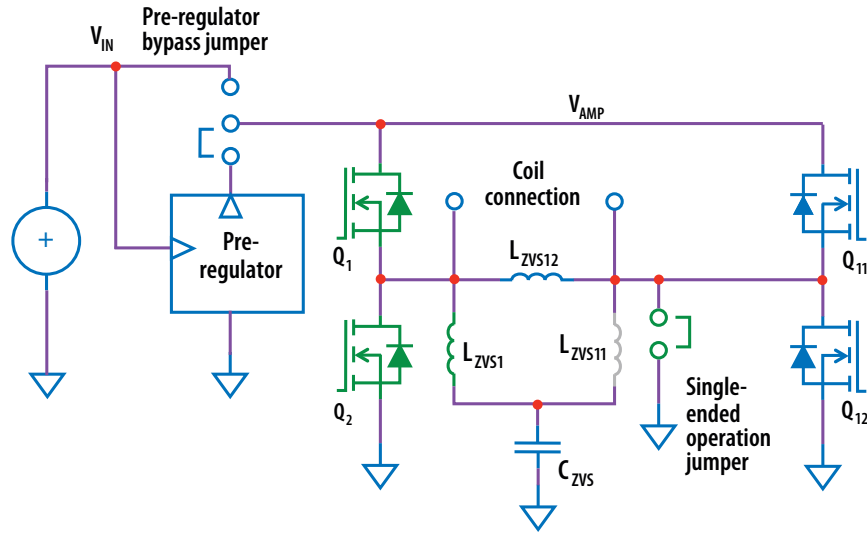

Figure 1: Diagram of EPC9508 Amplifier Board

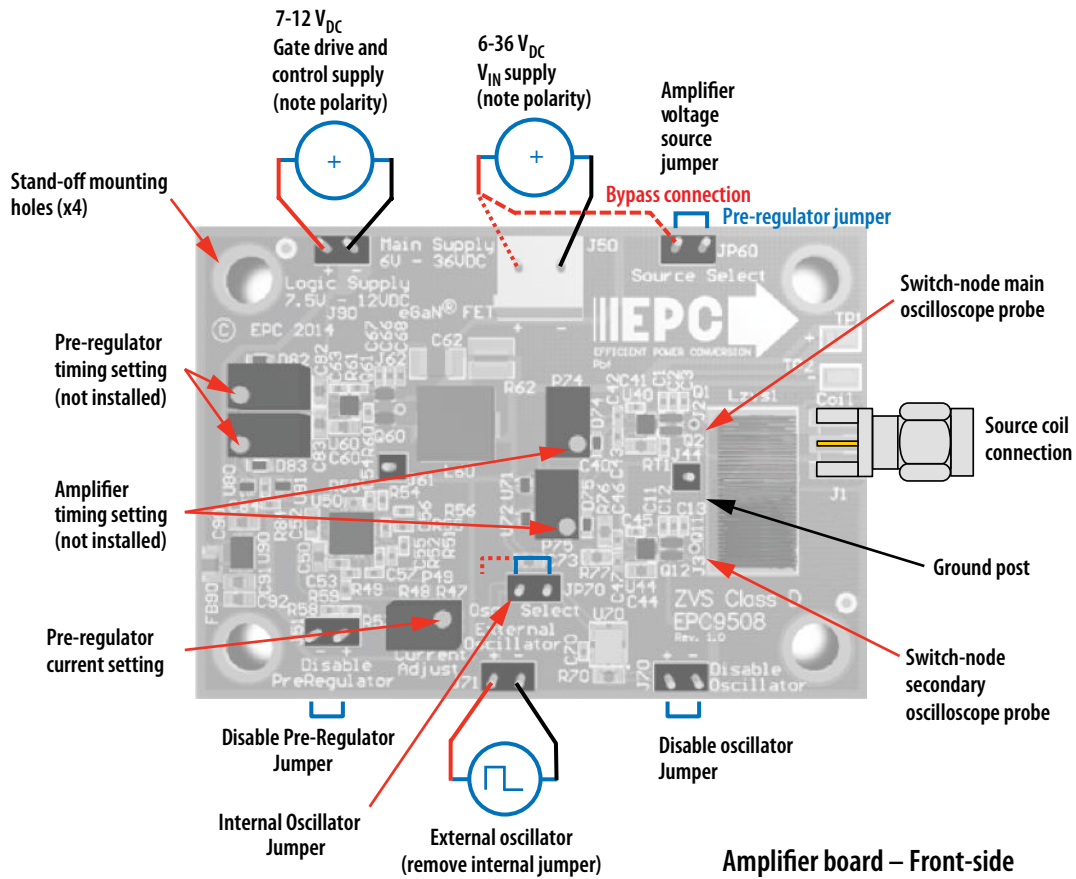

Figure 2: Proper Connection and Measurement Setup for the EPC9508 Amplifier Board

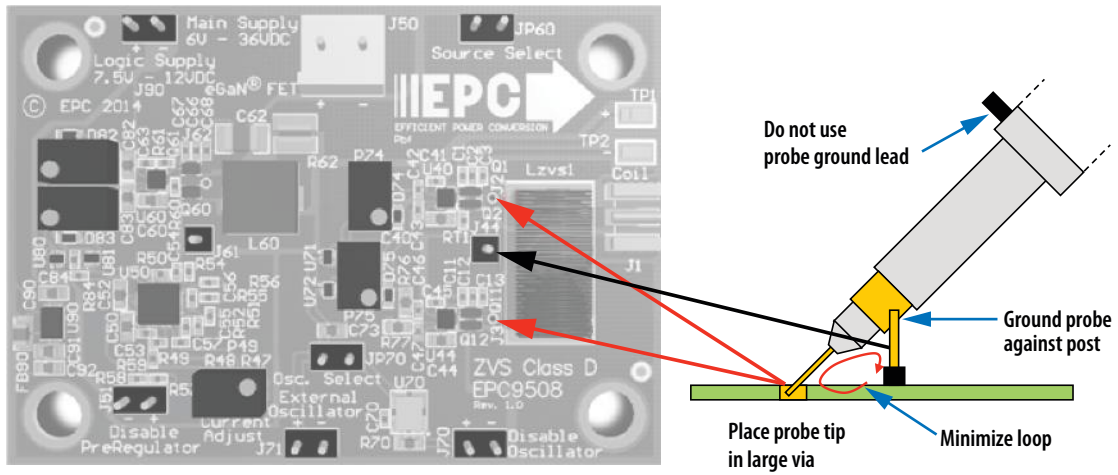

Figure 3: Proper Measurement of the Switch Nodes Using the Hole and Ground Post

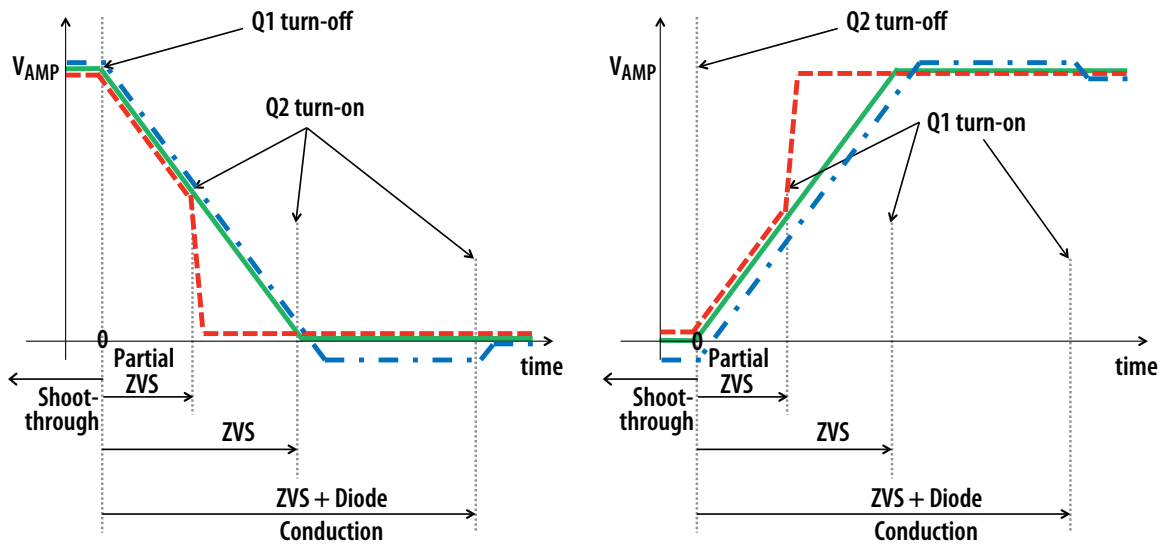

Figure 4: ZVS Timing Diagrams

Table 2: Bill of Materials - Amplifier Board

Item	Qty	Reference	Part Description	Manufacturer	Part #
1	10	C1, C2, C3, C11, C12, C13, C55, C66, C67, C68	10nF, 100 V	TDK	C1005X7S2A103K050BB
2	2	C5, C15	1.0 μ F, 100 V	TDK	C2012X7S2A105K125AB
3	4	C40, C44 C52, C60	4.7 μ F, 16V	TDK	C1608X5R1C475K
4	2	C41, C45	22 nF, 25 V	TDK	C1005X7R1E223K050BB
5	5	C42, C43, C46, C47 C84	47 pF, 50 V	Yageo	CC0402JRNPO9BN470
6	1	C50	1 μ F, 50 V	Taiyo Yuden	UMK107AB7105KA-T
7	2	C53, C54	2.2 nF, 50 V	Yageo	CC0402KRX7R9BB222
8	1	C56	1 nF, 50 V	Yageo	CC0402KRX7R9BB102
9	4	C57, C58, C63, C70	100 nF, 25 V	TDK	C1005X7R1E104K050BB
10	3	C62, C64, C65	2.2 μ F, 100 V	Taiyo Yuden	HMK325B7225KN-T
11	4	C71, C72, C80, C81	100 nF, 25 V	TDK	C1608X7R1E104K
12	1	C73	DNP, 100 pF, 25 V	Generic	Generic
13	2	C82, C83	100 pF, 25 V	TDK	C1608C0G1H101J080AA
14	3	C90, C91, C92	1 μ F, 25 V	TDK	C1608X7R1E105K
15	1	Czvs1	DNP 1 μ F, 50 V	Taiyo Yuden	C2012X7R1H105K125AB
16	4	D74, D75, D82, D83	40 V, 30 mA	Diodes Inc.	SDM03U40
17	2	FB90, FB91	0.3DC 600AC	Laird	HZ0805E601R-10
18	1	J1	SMA Board Edge	Linx	CONREVSMA013.062
19	2	J44, J61	.1" Male Vert., 1 pin	Würth	61300111121
20	2	JP61, JP71	Jumper 100	Würth	60900213421
21	6	J51, J70, J71, J90, JP60, JP70	.1" Male Vert., 2 pin	Würth	61300311121
22	1	J50	.156" Male Vert.	Würth	645002114822
23	1	L60	10 μ H	Würth	744314101
24	2	Lzvs1, Lzvs11	430 nH	CoilCraft	2929SQ-431JEB
25	1	P49	DNP, 10 k	Murata	PV37Y103C01B00
26	4	P74, P75, P82, P83	DNP, 1k	Murata	PV37Y102C01B00
27	4	Q1, Q2, Q11, Q12	65 V, 4.1A, 138 m Ω	EPC	EPC8009
28	2	Q60, Q61	100 V, 6A, 30 m Ω	EPC	EPC2007
29	1	R47	6.04 k	Panasonic	ERJ-2RKF6041X
30	1	R48	2.74 k	Panasonic	ERJ-2RKF2741X
31	1	R49	3.3 k	Panasonic	ERJ-2RKF3301X
32	1	R50	40.2 k	Yageo	RC0402FR-0740K2L
33	1	R51	280 k	Panasonic	ERJ-2RKF2803X
34	1	R52	10 k	Yageo	RC0402FR-0710KL
35	1	R54	15 k	Yageo	RC0402JR-0715KL
36	3	R55, R56, R84	10 Ω	Yageo	RC0402FR-0710RL
37	1	R57	374 k	Panasonic	ERJ-2RKF3743X
38	1	R58	124 k	Panasonic	ERJ-2RKF1243X
39	1	R59	45.3 k	Panasonic	ERJ-2RKF4532X
40	2	R60, R61	2.2 Ω	Yageo	RC0402JR-072R2L
41	1	R62	24 m Ω 1 W	Susumu	PRL1632-R024-F-T1
42	1	R70	47 k	Stackpole	RMCF0603JT47K0
43	1	R73	10 k	Yageo	RC0603JR-0710KL
44	1	R74, R75	75 Ω	Panasonic	ERJ-3EKF75R0V
45	2	R76, R77	0 Ω	Yageo	RC0603JR-070RL
46	1	R82	31.6 Ω	Panasonic	ERJ-3EKF31R6V
47	1	R83	191 Ω	Panasonic	ERJ-3EKF1910V
48	1	RT1	470 k at 25 $^{\circ}$ C	Murata	NCP15WM474E03RC
50	2	TP1, TP2	SMD probe loop	Keystone	5015
51	3	U40, U44, U60	100 V eGaN Driver	Texas Instruments	LM5113TM
52	1	U50	Step Down Controller	Linear Technologies	LT3741EUF#PBF
53	1	U70	Programmable Oscillator – 6.78 MHz	EPSON	SG-8002CE
54	2	U71, U80	2 In AND	Fairchild	NC7SZ08L6X
55	2	U72, U81	2 In NAND	Fairchild	NC7SZ00L6X
56	1	U90	5.0 V, 250 mA, DFN	Microchip	MCP1703T-5002E/MC

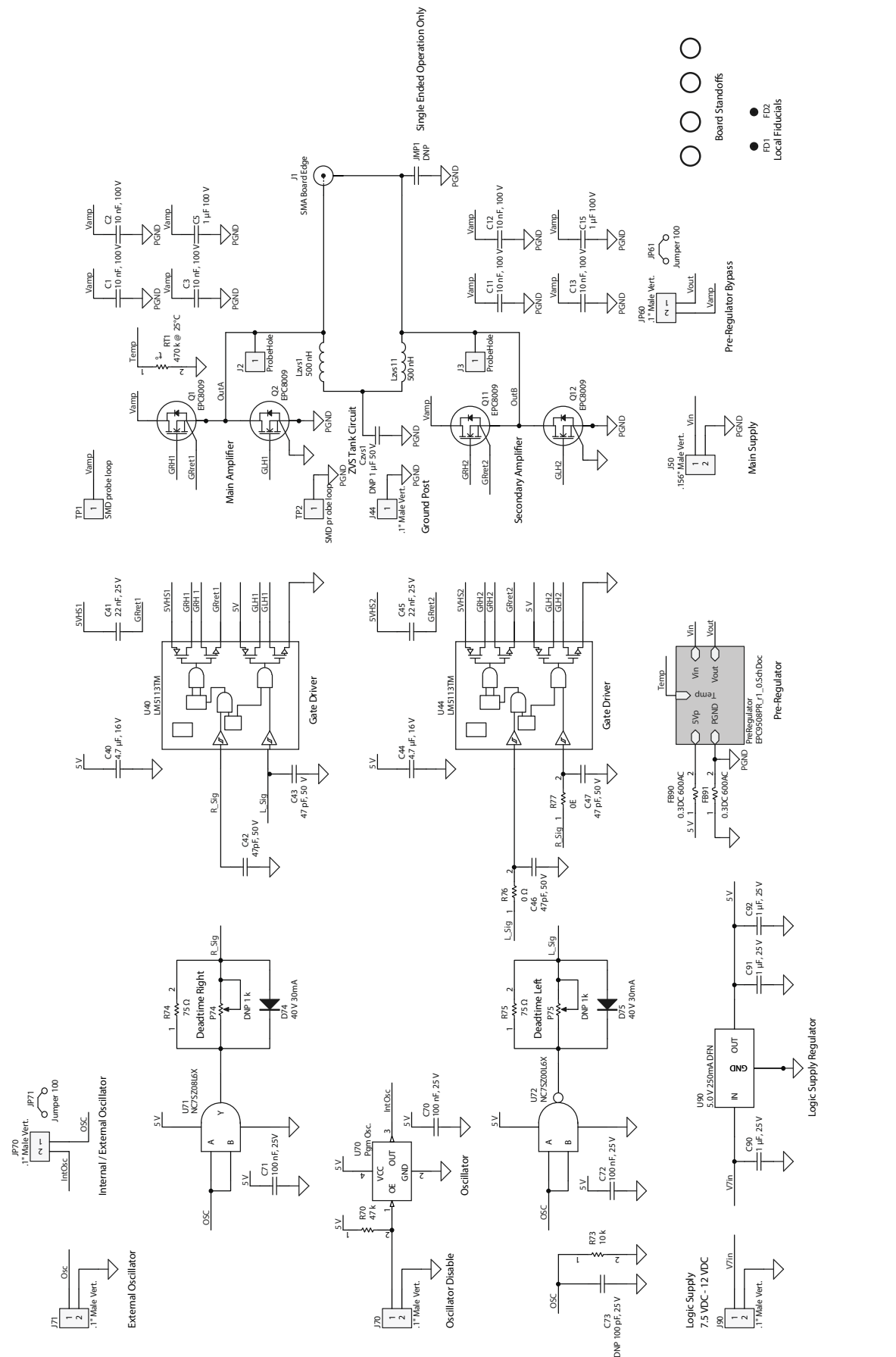

Figure 5: EPC9508 Source Board Amplifier Schematic

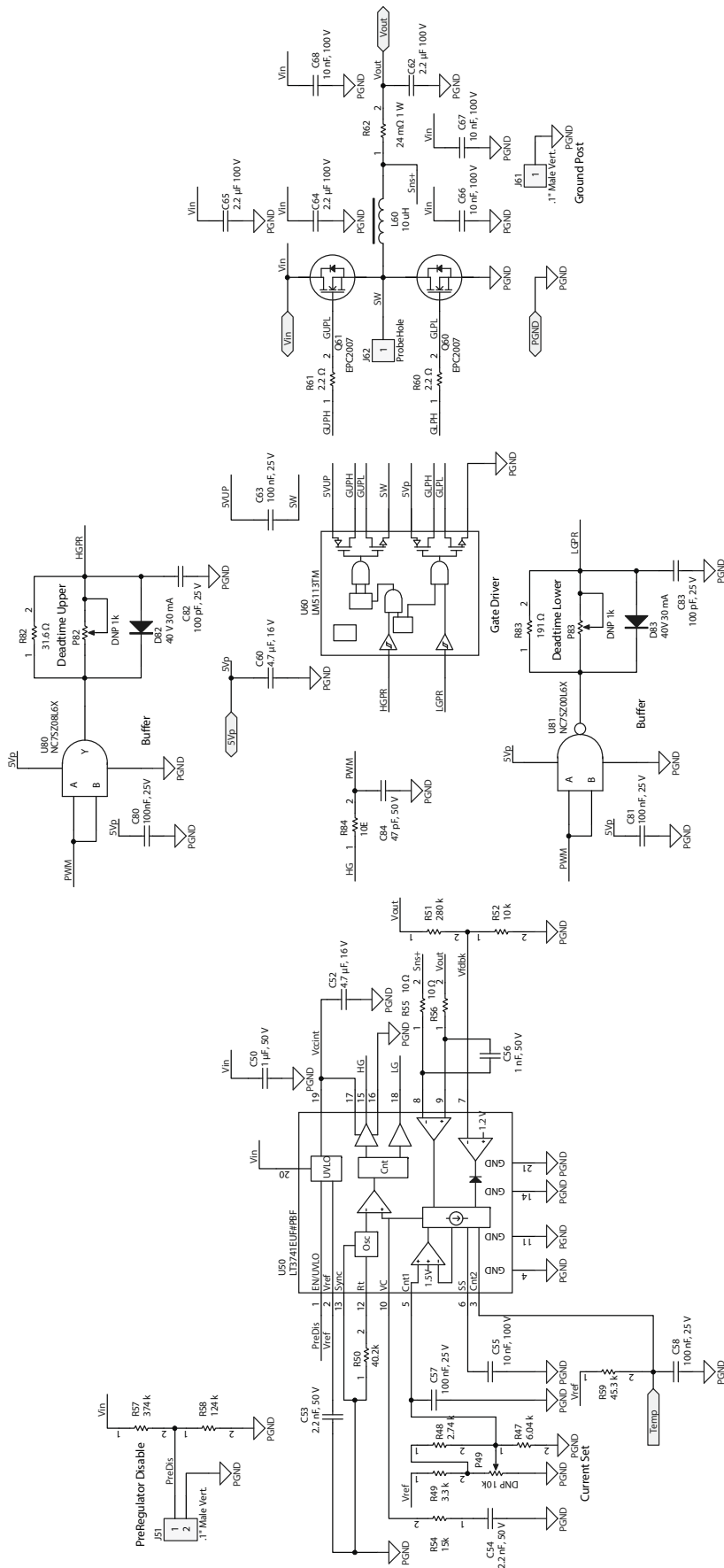

Figure 6: EPC9508 -Source Board Pre-Regulator Schematic

For More Information:

Please contact info@epc-co.com
or your local sales representative

Visit our website:
www.epc-co.com

Sign-up to receive
EPC updates at
bit.ly/EPCupdates
or text "EPC" to 22828



EPC Products are distributed through Digi-Key.
www.digikey.com

Demonstration Board Warning and Disclaimer

The EPC9508 board is intended for product evaluation purposes only and is not intended for commercial use. Replace components on the Evaluation Board only with those parts shown on the parts list (or Bill of Materials) in the Quick Start Guide. Contact an authorized EPC representative with any questions.

This board is intended to be used by certified professionals, in a lab environment, following proper safety procedures. Use at your own risk.

As an evaluation tool, this board is not designed for compliance with the European Union directive on electromagnetic compatibility or any other such directives or regulations. As board builds are at times subject to product availability, it is possible that boards may contain components or assembly materials that are not RoHS compliant. Efficient Power Conversion Corporation (EPC) makes no guarantee that the purchased board is 100% RoHS compliant.

The Evaluation board (or kit) is for demonstration purposes only and neither the Board nor this Quick Start Guide constitute a sales contract or create any kind of warranty, whether express or implied, as to the applications or products involved.

Disclaimer: EPC reserves the right at any time, without notice, to make changes to any products described herein to improve reliability, function, or design. EPC does not assume any liability arising out of the application or use of any product or circuit described herein; neither does it convey any license under its patent rights, or other intellectual property whatsoever, nor the rights of others.