

Overview

KEMET's ALS42/43 Series of screw terminal capacitors features the same high ripple currents and long-life characteristics as the ALS32/33 Series but can operate at higher temperatures. They are similarly suited for high reliability and long-life applications such as frequency converters, uninterruptible power supply (UPS) systems, and switch mode power supplies (SMPS) but the extended temperature range allows increased ripple currents at lower temperatures.

Applications

Typical applications for KEMET's ALS 42/43 Series of capacitors include smoothing, energy storage or pulse operation in telecommunication demanding power supplies, process control, AC motor control, traction, and welding.

Benefits

- Case sizes and terminals for the Asian market
- Long life, up to 9,000 hours at +105°C (V_R, I_R applied)
- High ripple current
- Excellent surge voltage capability
- Optimized designs available upon request



Part Number System

ALS4	2	A	102	K3C	350
Series	Stud Option	Termination	Capacitance Code (μF)	Size Code	Rated Voltage (VDC)
Screw Terminal Aluminum Electrolytic	2 = Plain Can 3 = Threaded mounting stud	See Termination Table	First two digits represent significant figures. Third digit specifies number of zeros.	See Dimension Table	350 = 350 400 = 400 415 = 415 450 = 450

Performance Characteristics

Item	Performance Characteristics		
Capacitance Range	1,000 – 15,000 μ F		
Rated Voltage	350 – 450 VDC		
Operating Temperature	-40 to +105°C		
Storage Temperature Range	-55 to +105°C		
Capacitance Tolerance	\pm 20% at 120 Hz/+20°C		
Operational Lifetime	D (mm)	Rated Voltage and Ripple Current at +105°C (hours)	Rated Voltage at +105°C (hours)
	36	6,000	10,000
	51	7,000	11,000
	66	8,000	13,000
	77,90	9,000	15,000
End of Life Requirement	Δ C/C < \pm 10%, ESR < 2 x initial ESR value, IL < initial specified limit		
Shelf Life	2,000 hours at +85°C or 30,000 hours at +40°C 0 VDC		
Leakage Current	I = 0.003 CV or 6,000 (μ A, whichever is smaller)		
	C = rated capacitance (μ F), V = rated voltage (VDC). Voltage applied for 5 minutes at +20°C.		
Vibration Test Specifications	Case Length < 220 mm	0.75 mm displacement amplitude or 10 g maximum acceleration. Vibration applied for three 2-hour sessions at 10 – 55 Hz (Capacitor clamped by body).	No leakage of electrolyte or other visible damage. Deviations in capacitance from initial measurements must not exceed: Δ C/C < 5%
	Case Length \geq 220 mm	0.35 mm displacement amplitude or 5 g maximum acceleration. Vibration applied for three 0.5 hour sessions at 10 – 55 Hz (Capacitor clamped by body).	
Standards	IEC 60384-4 long life grade 40/105/56		

Surge Voltage

Condition	Voltage (VDC)			
	350	400	415	450
\leq 30 s surge, 1,000 cycles at +85°C	400	450	456.5	500
\leq 500 ms surge, 100 cycles at +20°C	500	520	530	550

Test Method & Performance

Endurance Life Test	
Conditions	Performance
Temperature	+105°C
Test Duration	2,000 hours
Ripple Current	Maximum ripple current specified in table
Voltage	The sum of DC voltage and the peak AC voltage must not exceed the rated voltage of the capacitor
Performance	The following specifications will be satisfied when the capacitor is tested at +20°C:
Capacitance Change	Within 10% of the initial value
Equivalent Series Resistance	Does not exceed 200% of the initial value
Leakage Current	Does not exceed leakage current limit

Termination Table

Termination Code	Thread	Termination Style	T	DT	Thread Depth (TD)	Z
			±0.8	±0.5	Minimum	Nominal
Standard Termination Option						
A (D = 35)	M5	Oval	7.14	8	10	
A (D ≥ 51)	M5	Oval	5.5	13	10	10
Other Termination Options						
C (D ≥ 63.5)	M6	Round	5.5	13	10	
Dimensions in mm						

Case Polarity

Due to the presence of electrolyte in the capacitor, the aluminum can and stud mounting will essentially be at the same polarity as the negative terminal. We recommend that the stud and can be insulated (see accessories for insulating nuts).

Terminations

Aluminum inserts with M5 threads as standard, maximum torque 2NM. Optional M6 threaded inserts have a maximum torque 4NM. Maximum torque for stud mounting M8:4NM and M12:8NM.

NOT FOR NEW DESIGN

Screw Terminal Aluminum Electrolytic Capacitors – ALS42/43, +105°C

Dimensions – Millimeters

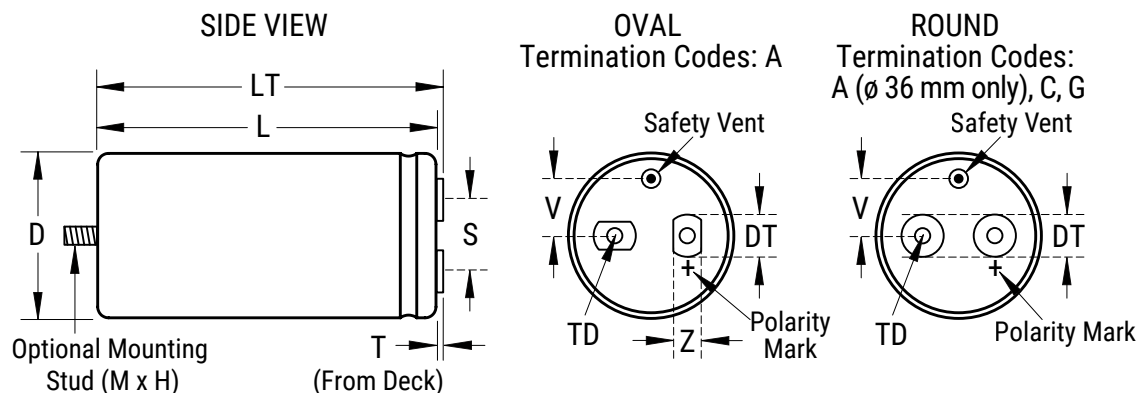

Reference Size (mm)	Size Code	Dimensions in mm						Mounting Stud (M x H)	Mounting Clip	Approximate Weight Grams
		D	L	LT	S	T	V			
		±0.8	±1.6	±1	±0.5	±0.8	Nominal	±1		
51 x 80	K3C	50.8	79.4	86.0	22.2	5.5	13.7	M12 x 16	V4/2737	240
51 x 93	K3L	50.8	92.1	98.0	22.2	5.5	13.7	M12 x 16	V4/2737	275
51 x 115	KJA	50.8	114.3	119.0	22.2	5.5	13.7	M12 x 16	V4/2737	340
51 x 131	K5C	50.8	130.2	136.0	22.2	5.5	13.7	M12 x 16	V4/2737	385
63.5 x 93	L3L	63.5	92.1	97.0	28.5	5.5	15.8	M12 x 16	V8	430
63.5 x 115	LJA	63.5	114.3	119.0	28.5	5.5	15.8	M12 x 16	V8	535
63.5 x 131	L5C	63.5	130.2	135.0	28.5	5.5	15.8	M12 x 16	V8	600
63.5 x 150	L5R	63.5	149.2	154.0	28.5	5.5	15.8	M12 x 16	V8	690
63.5 x 194	L7L	63.5	193.7	198.0	28.5	5.5	15.8	M12 x 16	V8	890
77 x 115	NJA	76.2	114.3	119.0	31.8	5.5	19	M12 x 16	V11	770
77 x 131	N5C	76.2	130.2	135.0	31.8	5.5	19	M12 x 16	V11	865
77 x 150	N5R	76.2	149.2	154.0	31.8	5.5	19	M12 x 16	V11	990
77 x 194	N7L	76.2	193.7	198.0	31.8	5.5	19	M12 x 16	V11	1,280
90 x 150	Q5R	88.9	149.2	154.0	31.8	5.5	25	M12 x 16	PYC6045	1,360
90 x 194	Q7L	88.9	193.7	198.0	31.8	5.5	25	M12 x 16	PYC6045	1,870
90 x 220	Q8L	88.9	219.1	224.0	31.8	5.5	25	M12 x 16	PYC6045	2,000

Note: Add 0.4 mm to D (1.1 mm when D = 88.9) and 1.1 mm to L for sleeving. LT listed is for A-type termination code. Information for other termination codes is available upon request.

Shelf Life

The capacitance, ESR and impedance of a capacitor will not change significantly after extended storage periods, however the leakage current will very slowly increase. KEMET products are particularly stable and allow a shelf life in excess of three years at 40°C. See sectional specification under each product series for specific data.

Re-age (Reforming) Procedure

Apply the rated voltage to the capacitor at room temperature for a period of one hour, or until the leakage current has fallen to a steady value below the specified limit. During re-aging a maximum charging current of twice the specified leakage current or 5 mA (whichever is greater) is suggested.

Reliability

The reliability of a component can be defined as the probability that it will perform satisfactorily under a given set of conditions for a given length of time.

In practice, it is impossible to predict with absolute certainty how any individual component will perform; thus, we must utilize probability theory. It is also necessary to clearly define the level of stress involved (e.g. operating voltage, ripple current, temperature and time). Finally, the meaning of satisfactory performance must be defined by specifying a set of conditions which determine the end of life of the component.

Reliability as a function of time, $R(t)$, is normally expressed as: $R(t) = e^{-\lambda t}$

where $R(t)$ is the probability that the component will perform satisfactorily for time t , and λ is the failure rate.

Failure Rate

The failure rate is the number of components failing per unit time. The failure rate of most electronic components follows the characteristic pattern:

- Early failures are removed during the manufacturing process.
- The operational life is characterized by a constant failure rate.
- The wear out period is characterized by a rapidly increasing failure rate.

The failures in time (FIT) are given with a 60% confidence level for the various type codes. By convention, FIT is expressed as 1×10^{-9} failures per hour. Failure rate is also expressed as a percentage of failures per 1,000 hours.

e.g., 100 FIT = 1×10^{-7} failures per hour = 0.01%/1,000 hours

End of Life Definition

Catastrophic Failure: short circuit, open circuit or safety vent operation

Parametric Failure:

- Change in capacitance $> \pm 10\%$
- Leakage current $>$ specified limit
- ESR $> 2 \times$ initial ESR value

MTBF

The mean time between failures (MTBF) is simply the inverse of the failure rate.

$$\text{MTBF} = 1/\lambda$$

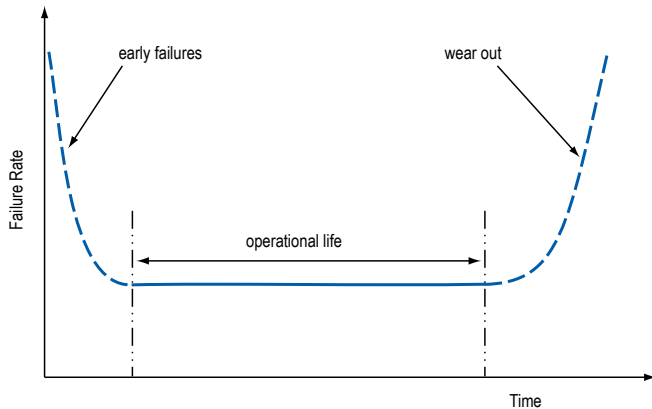

The failure rate is derived from our periodic test results. The failure rate (λ_R) is, therefore, only given at test temperature for life tests. An estimation is also given at 40°C. The expected failure rate for this capacitor range is based on our periodic test results for capacitors with structural similarity. Failure rate is frequently quoted in FIT (Failures In Time) where 1 FIT = 1×10^{-9} failures per hour. Failure rate per hour includes both catastrophic and parametric failures.

T_a	Failure Rate per Hour
85°C	220 FIT
40°C	10 FIT

Environmental Compliance

As an environmentally conscious company, KEMET is working continuously with improvements concerning the environmental effects of both our capacitors and their production. In Europe (RoHS Directive) and in some other geographical areas like China, legislation has been put in place to prevent the use of some hazardous materials, such as lead (Pb), in electronic equipment. All products in this catalog are produced to help our customers' obligations to guarantee their products and fulfill these legislative requirements. The only material of concern in our products has been lead (Pb), which has been removed from all designs to fulfill the requirement of containing less than 0.1% of lead in any homogeneous material. KEMET will closely follow any changes in legislation world wide and makes any necessary changes in its products, whenever needed.

Some customer segments such as medical, military and automotive electronics may still require the use of lead in electrode coatings. To clarify the situation and distinguish products from each other, a special symbol is used on the packaging labels for RoHS compatible capacitors.

Because of customer requirements, there may appear additional markings such as LF = Lead Free or LFW = Lead Free Wires on the label.

NOT FOR NEW DESIGN

Screw Terminal Aluminum Electrolytic Capacitors – ALS42/43, +105°C

Table 1 – Ratings & Part Number Reference

VDC	Rated Capacitance	Size Code	Case Size	Ripple Current		ESR Maximum		Part Number
	120 Hz 25°C (µF)		D x L (mm)	120 Hz 105°C (A)	20 kHz 105°C (A)	120 Hz 25°C (mΩ)	20 kHz 25°C (mΩ)	
350	1000	K3C	51 x 80	5.0	9.9	121	78	ALS4(1)(2)102K3C350
350	1200	K3C	51 x 80	5.3	10.1	103	67	ALS4(1)(2)122K3C350
350	1500	K3L	51 x 93	6.2	11.3	81	53	ALS4(1)(2)152K3L350
350	1800	K3L	51 x 93	6.6	11.2	70	46	ALS4(1)(2)182K3L350
350	2200	K5C	51 x 131	8.3	14.8	58	38	ALS4(1)(2)222K5C350
350	2700	L3L	63.5 x 93	9.6	16.5	48	32	ALS4(1)(2)272L3L350
350	3300	LJA	63.5 x 115	11.2	18.9	39	26	ALS4(1)(2)332LJA350
350	3900	L5C	63.5 x 131	12.5	19.7	36	25	ALS4(1)(2)392L5C350
350	4700	L5R	63.5 x 150	13.5	20.8	31	22	ALS4(1)(2)472L5R350
350	4700	NJA	77 x 115	13.5	20	30	21	ALS4(1)(2)472NJA350
350	5600	L7L	63.5 x 194	14.9	23.4	24	17	ALS4(1)(2)562L7L350
350	5600	N5C	77 x 131	15.0	20.8	28	21	ALS4(1)(2)562N5C350
350	6800	N5R	77 x 150	16.5	22.5	24	18	ALS4(1)(2)682N5R350
350	8200	Q5R	90 x 150	20.9	29.5	18	13	ALS4(1)(2)822Q5R350
350	10000	Q5R	90 x 150	21.5	28.4	16	12	ALS4(1)(2)103Q5R350
350	12000	Q7L	90 x 194	26.5	35.9	14	10	ALS4(1)(2)123Q7L350
350	15000	Q8L	90 x 220	31.8	41.3	12	9	ALS4(1)(2)153Q8L350
400	1000	K3C	51 x 80	5.2	10.1	103	65	ALS4(1)(2)102K3C400
400	1200	K3L	51 x 93	5.9	11.2	87	55	ALS4(1)(2)122K3L400
400	1500	KJA	51 x 115	7.1	13.4	70	44	ALS4(1)(2)152KJA400
400	1800	K5C	51 x 131	8.0	14.8	59	37	ALS4(1)(2)182K5C400
400	2200	L3L	63.5 x 93	9.3	16.4	49	31	ALS4(1)(2)222L3L400
400	2700	LJA	63.5 x 115	10.8	18.9	40	26	ALS4(1)(2)272LJA400
400	3300	L5C	63.5 x 131	12.3	20.0	33	22	ALS4(1)(2)332L5C400
400	3900	L5R	63.5 x 150	13.1	20.7	31	21	ALS4(1)(2)392L5R400
400	3900	NJA	77 x 115	13.1	19.9	31	21	ALS4(1)(2)392NJA400
400	4700	L7L	63.5 x 194	14.4	23.1	25	17	ALS4(1)(2)472L7L400
400	4700	N5C	77 x 131	14.6	20.6	29	20	ALS4(1)(2)472N5C400
400	5600	L7L	63.5 x 194	15.2	23.0	22	15	ALS4(1)(2)562L7L400
400	5600	N5R	77 x 150	16.1	22.3	24	17	ALS4(1)(2)562N5R400
400	6800	Q5R	90 x 150	20.4	29.3	18	12	ALS4(1)(2)682Q5R400
400	8200	Q5R	90 x 150	20.9	28.1	16	12	ALS4(1)(2)822Q5R400
400	10000	Q7L	90 x 194	25.9	35.8	14	10	ALS4(1)(2)103Q7L400
400	12000	Q8L	90 x 220	30.9	41.2	12	9	ALS4(1)(2)123Q8L400
415	1000	K3C	51 x 80	5.3	10.1	98	61	ALS4(1)(2)102K3C415
415	1200	K3L	51 x 93	6.0	10.9	87	57	ALS4(1)(2)122K3L415
415	1500	KJA	51 x 115	7.2	13.5	66	42	ALS4(1)(2)152KJA415
415	1800	K5C	51 x 131	8.2	14.8	56	35	ALS4(1)(2)182K5C415
415	2200	L3L	63.5 x 93	9.4	16.1	49	32	ALS4(1)(2)222L3L415
415	2700	LJA	63.5 x 115	11.0	18.6	40	27	ALS4(1)(2)272LJA415
415	3900	L5R	63.5 x 150	13.7	22.1	29	19	ALS4(1)(2)392L5R415
415	3900	NJA	77 x 115	13.2	19.5	31	21	ALS4(1)(2)392NJA415
415	4700	N5C	77 x 131	14.6	20.6	29	20	ALS4(1)(2)472N5C415
415	4700	L7L	63.5 x 194	14.7	23.1	24	16	ALS4(1)(2)472L7L415
415	5600	L7L	63.5 x 194	15.4	22.9	21	15	ALS4(1)(2)562L7L415
415	5600	N5R	77 x 150	16.1	22.3	24	17	ALS4(1)(2)562N5R415
415	6800	Q5R	90 x 150	20.4	29.3	18	12	ALS4(1)(2)682Q5R415
415	8200	Q5R	90 x 150	20.9	28.1	16	12	ALS4(1)(2)822Q5R415
415	10000	Q7L	90 x 194	25.9	35.8	14	10	ALS4(1)(2)103Q7L415
415	12000	Q8L	90 x 220	30.9	41.2	12	9	ALS4(1)(2)123Q8L415
450	1000	K3L	51 x 93	5.8	11.2	89	54	ALS4(1)(2)102K3L450
450	1200	KJA	51 x 115	6.8	13.4	73	44	ALS4(1)(2)122KJA450
450	1500	K5C	51 x 131	7.8	14.8	60	37	ALS4(1)(2)152K5C450
450	1800	L3L	63.5 x 93	9.0	16.4	51	31	ALS4(1)(2)182L3L450
450	2200	LJA	63.5 x 115	10.5	18.9	42	26	ALS4(1)(2)222LJA450
450	2700	L5C	63.5 x 131	12.2	21.5	34	21	ALS4(1)(2)272L5C450
450	2700	NJA	77 x 115	12.3	20.3	36	23	ALS4(1)(2)272NJA450
VDC	Rated Capacitance	Size Code	Case Size	Ripple Current		ESR		Part Number

(1) Mounting Code: 2 = plain can, 3 = threaded mounting stud

(2) Termination Code: See Termination Tables for available options

NOT FOR NEW DESIGN

Table 1 – Ratings & Part Number Reference cont.

VDC	Rated Capacitance	Size Code	Case Size	Ripple Current		ESR Maximum		Part Number
	120 Hz 25°C (µF)		D x L (mm)	120 Hz 105°C (A)	20 kHz 105°C (A)	120 Hz 25°C (mΩ)	20 kHz 25°C (mΩ)	
450	3300	L5R	63.5 x 150	13.2	22.1	30	20	ALS4(1)(2)332L5R450
450	3300	N5C	77 x 131	14.0	21.4	31	20	ALS4(1)(2)332N5C450
450	3900	L7L	63.5 x 194	14.2	23.3	25	16	ALS4(1)(2)392L7L450
450	4700	N5R	77 x 150	15.8	22.2	25	17	ALS4(1)(2)472N5R450
450	5600	N7L	77 x 194	19.5	28.3	19	13	ALS4(1)(2)562N7L450
450	5600	Q5R	90 x 150	19.8	28.8	20	14	ALS4(1)(2)562Q5R450
450	6800	Q7L	90 x 194	24.3	36.2	16	11	ALS4(1)(2)682Q7L450
450	8200	Q7L	90 x 194	25.4	35.7	14	10	ALS4(1)(2)822Q7L450
450	10000	Q8L	90 x 220	30.4	41.2	12	9	ALS4(1)(2)103Q8L450
VDC	Rated Capacitance	Size Code	Case Size	Ripple Current		ESR		Part Number

(1) Mounting Code: 2 = plain can, 3 = threaded mounting stud

(2) Termination Code: See Termination Tables for available options

Mechanical Data

Polarity and Reversed Voltage

Aluminium Electrolytic capacitors manufactured for use in DC applications contain an anode foil and a cathode foil. As such, they are polarized devices and must be connected with the +ve to the anode foil and the -ve to the cathode foil. If this were to be reversed then the electrolytic process that took place in forming the oxide layer on the anode would be recreated in trying to form an oxide layer on the cathode. In forming the cathode foil in this way, heat would be generated and gas given off within the capacitor, usually leading to catastrophic failure.

The cathode foil already possesses a thin stabilized oxide layer. This thin oxide layer is equivalent to a forming voltage of approximately 2 V. As a result, the capacitor can withstand a voltage reversal of up to 2 V for short periods. Above this voltage, the formation process will commence. Aluminium Electrolytic capacitors can also be manufactured for use in intermittent AC applications by using two anode foils in place of one anode and one cathode.

Mounting Position

The capacitor can be mounted in any position as long as the safety vent can operate. It is possible for some electrolyte to be expelled. As this is a conducting liquid, suitable precautions should be initiated by the system designer to avoid secondary short circuits.

The capacitors are designed to be mounted in free air and are not suitable for submersion in liquid.

Vibration

10 – 55 Hz at 0.75 mm or 10 g for 3 x 2 hours duration, except 220 mm long cans 10 – 55 Hz at 0.35 mm or 5 g for 3 x 0.5 hours duration. Custom designs can be made in a 66 mm diameter (M6 deck), with a vibration capability of 20 g (10 – 56 Hz at 0.75 mm and 56 – 500 Hz 20 g for 3 x 0.5 hours duration).

Insulating Resistance

≥ 100 MΩ at 100 VDC across insulating sleeve. UL recognized sleeving is available for custom parts in this range, upon request.

(UL No. E358957)

Voltage Proof

≥ 2,500 VDC across insulating sleeve

Safety Vent

A safety vent for overpressure is featured on terminal deck. This is in the form of a rubber plug designed to relieve build-up of internal pressure due to overstress or catastrophic failure.

NOT FOR NEW DESIGN

Screw Terminal Aluminum Electrolytic Capacitors – ALS42/43, +105°C

Marking

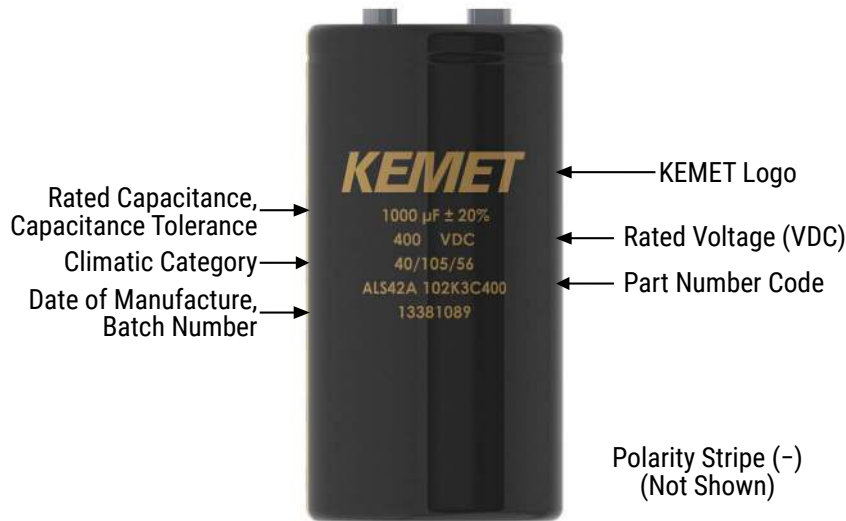

Construction

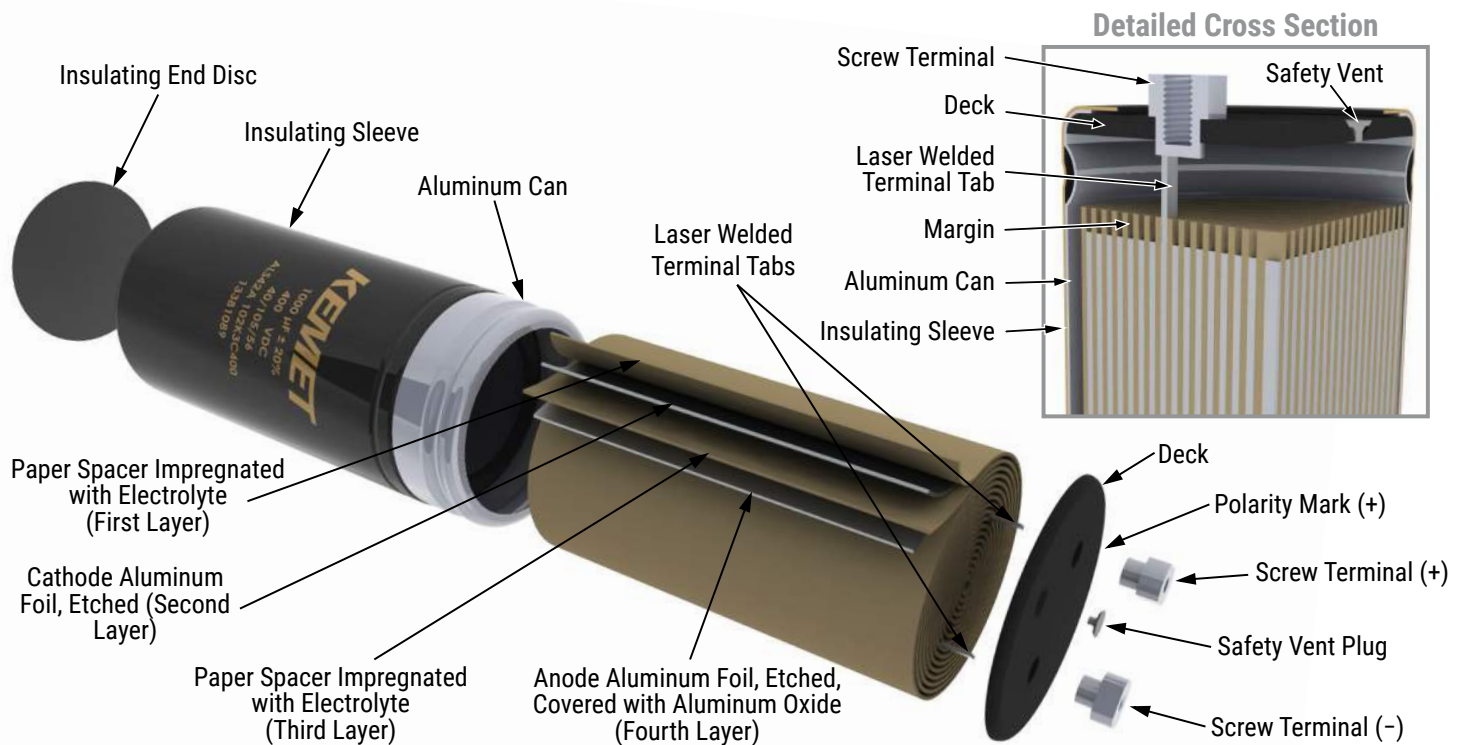

Construction Data

The manufacturing process begins with the anode foil being electrochemically etched to increase the surface area and then “formed” to produce the aluminum oxide layer. Both the anode and cathode foils are then interleaved with absorbent paper and wound into a cylinder. During the winding process, aluminum tabs are attached to each foil to provide the electrical contact.

The deck, complete with terminals, is attached to the tabs and then folded down to rest on top of the winding. The complete winding is impregnated with electrolyte before being housed in a suitable container, usually an aluminum can, and sealed. Throughout the process, all materials inside the housing must be maintained at the highest purity and be compatible with the electrolyte.

Each capacitor is aged and tested before being sleeved and packed. The purpose of aging is to repair any damage in the oxide layer and thus reduce the leakage current to a very low level. Aging is normally carried out at the rated temperature of the capacitor and is accomplished by applying voltage to the device while carefully controlling the supply current. The process may take several hours to complete.

Damage to the oxide layer can occur due to variety of reasons:

- Slitting of the anode foil after forming
- Attaching the tabs to the anode foil
- Minor mechanical damage caused during winding

A sample from each batch is taken by the quality department after completion of the production process. This sample size is controlled by the use of recognized sampling tables defined in BS 6001.

The following tests are applied and may be varied at the request of the customer. In this case the batch, or special procedure, will determine the course of action.

Electrical:

- Leakage current
- Capacitance
- ESR
- Impedance
- Tan Delta

Mechanical/Visual:

- Overall dimensions
- Torque test of mounting stud
- Print detail
- Box labels
- Packaging, including packed quantity

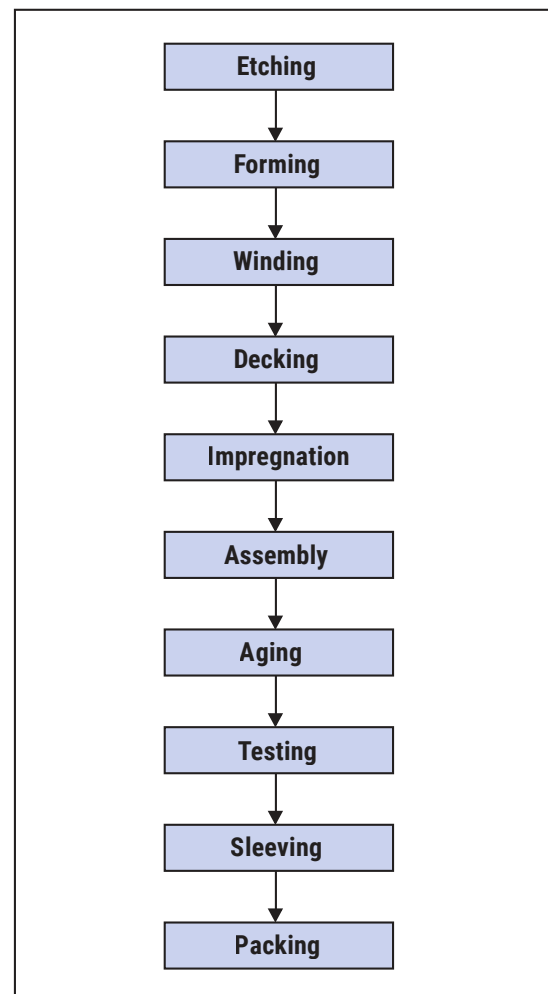
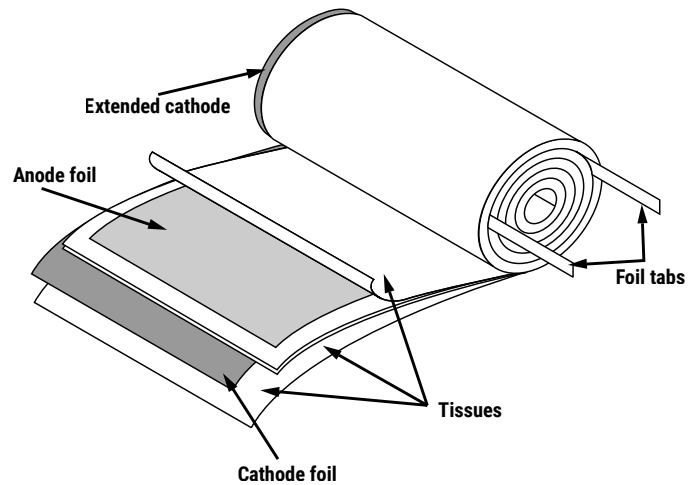

KEMET Electronics Corporation Sales Offices

For a complete list of our global sales offices, please visit www.kemet.com/sales.

Disclaimer

All product specifications, statements, information and data (collectively, the "Information") in this datasheet are subject to change. The customer is responsible for checking and verifying the extent to which the Information contained in this publication is applicable to an order at the time the order is placed. All Information given herein is believed to be accurate and reliable, but it is presented without guarantee, warranty, or responsibility of any kind, expressed or implied.

Statements of suitability for certain applications are based on KEMET Electronics Corporation's ("KEMET") knowledge of typical operating conditions for such applications, but are not intended to constitute – and KEMET specifically disclaims – any warranty concerning suitability for a specific customer application or use. The Information is intended for use only by customers who have the requisite experience and capability to determine the correct products for their application. Any technical advice inferred from this Information or otherwise provided by KEMET with reference to the use of KEMET's products is given gratis, and KEMET assumes no obligation or liability for the advice given or results obtained.

Although KEMET designs and manufactures its products to the most stringent quality and safety standards, given the current state of the art, isolated component failures may still occur. Accordingly, customer applications which require a high degree of reliability or safety should employ suitable designs or other safeguards (such as installation of protective circuitry or redundancies) in order to ensure that the failure of an electrical component does not result in a risk of personal injury or property damage.

Although all product-related warnings, cautions and notes must be observed, the customer should not assume that all safety measures are indicated or that other measures may not be required.

KEMET requires its products to be packaged and shipped on pallets. This is because KEMET's products are specifically designed to be packed onto pallets during shipment. If for any reason, the products are removed from pallets by the shipping party and shipped to the end customer, then additional external protection is required. In this instance, an external box with two carton layers and an upwards orientation sticker must be used by the shipping party, with the empty space filled with filling material, and afterwards sealing the box. If this packing and packaging guideline is not followed by the shipping party, the shipping party, and not KEMET, will be held responsible for any packaging, packing and/or product damages upon delivery of the products to the end customer. KEMET hereby disclaims any liability for damages to the products or otherwise that have been, or threaten to be, inflicted, result from or are in any way related to the packaging, packing or damage by the shipping party in contravention of the packing and packaging guidelines herein.

KEMET is a registered trademark of KEMET Electronics Corporation.