

1

2

3

4

5

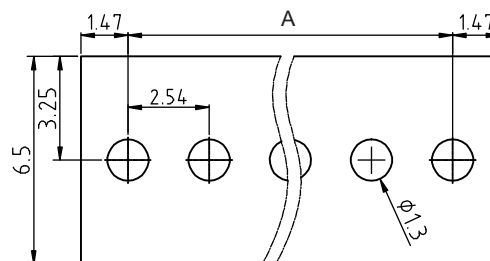
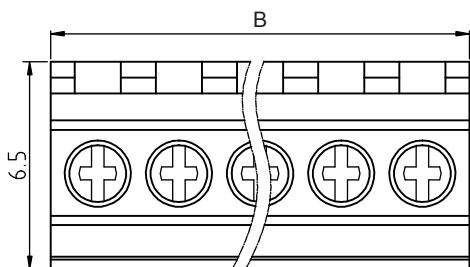
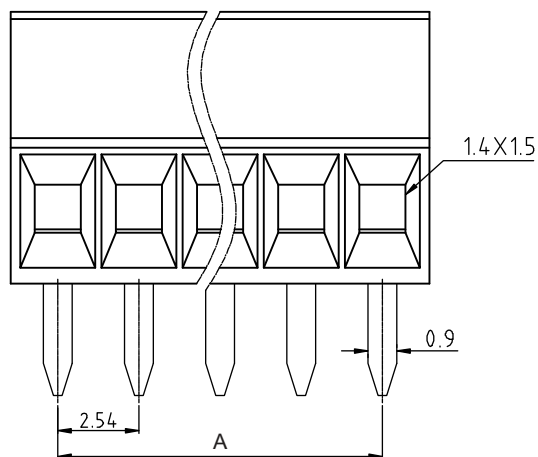
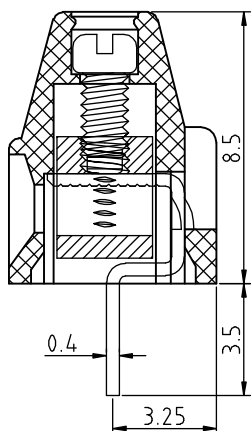

PCB LAYOUT - COMPONENT VIEW

## TECHNICAL CHARACTERISTICS

MATERIAL  
 INSULATOR: PA 66  
 FLAMMABILITY RATING: UL94-V0  
 COLOR: GREEN  
 METAL HOUSING: BRASS (CuZn)  
 TERMINAL SCREW: STEEL ZINC PLATING "+-" SLOT TYPE  
 CONTACTS: BRASS  
 SURFACE OF SOLDER TAIL PLATING: TIN

ENVIRONMENTAL  
 OPERATING TEMPERATURE: -40 UP TO 105°C  
 COMPLIANCE: LEAD FREE AND ROHS

ELECTRICAL  
 CURRENT RATING: 6 A  
 WORKING VOLTAGE: 150 VAC  
 WITHSTANDING VOLTAGE: 1.3 KV  
 CONTACT RESISTANCE: 20 mOhm MAX

STANDARD  
 cULus CERTIFIED E315414

MECHANICAL  
 SOLID WIRE: 30-18 AWG / 0.0509-0.823 MM<sup>2</sup>  
 STRANDED WIRE: 30-18 AWG / 0.0509-0.823 MM<sup>2</sup>  
 TORQUE: 1.3 Lb.In / 0.15 Nm

WIRE STRIPE LENGTH: 4-5 MM  
 SCREW: M1.6  
 PITCH: 2.54 MM

SOLDERING  
 JEDEC LEAD FREE WAVE SOLDERING PROCESS

PACKAGING  
 BOX

DIMENSION  
 A = (NB. PIN -1) x2,54  
 B = (NB. PIN x2,54) + 0,4

RoHS Compliant

G				PROJECTION: 	GENERAL TOLERANCE .X = +/- 0.2 .XX = +/- 0.15		DESCRIPTION: SERIE 2109 - 2.54MM HORIZONTAL ENTRY WITH RISING CLAMP CAGE CLAMP - WR-TBL	SIZE <b>A4</b>
F								
E								
D								
C								
B	31-JUL-15	UPDATE	AK	APPROVAL: FBr	UNIT: MM	WERI PART NO: 691 210 910 0xx		
A	12-OCT-09	PDF	JP		SCALE:			
REV	DATE	FILE	BY		DRAW: MARVIN			

1

2

3

4

5

## Cautions and Warnings:

This electronic component is designed and developed with the intention for use in general electronics equipments.

Before incorporating the components into any equipments in the field such as aerospace, aviation, nuclear control, submarine, transportation, (automotive control, train control, ship control), transportation signal, disaster prevention, medical, public information network etc. where higher safety and reliability are especially required or if there is possibility of direct damage or injury to human body, Würth Elektronik must be asked for a written approval.

In addition, even electronic component in general electronic equipments, when used in electrical circuits that require high safety, reliability functions or performance, the sufficient reliability evaluation-check for the safety must be performed before by the user before usage.

A

B

C

RoHS Compliant

G				PROJECTION: 	GENERAL TOLERANCE .X = +/- 0.2 .XX = +/- 0.15		
F							
E							
D							
C				APPROVAL: JC	UNIT: MM	DESCRIPTION: DISCLAIMER	SIZE <b>A4</b>
B					SCALE:		
A	10-SEP-14	PDF	QL		SHEET: 2/2	WERI PART NO: DISCLAIMER	
REV	DATE	FILE	BY		DRAW: QL		

D