

THIS DRAWING IS UNPUBLISHED. RELEASED FOR PUBLICATION 20
 © COPYRIGHT 20 BY - ALL RIGHTS RESERVED.

LOC	DIST	REVISIONS					
GP	00	P	LTR	DESCRIPTION	DATE	DWN	APVD
		6		UPDATE	25JUN2013	JY	AC
		A		INITIAL RELEASE	16DEC2014	JY	MC

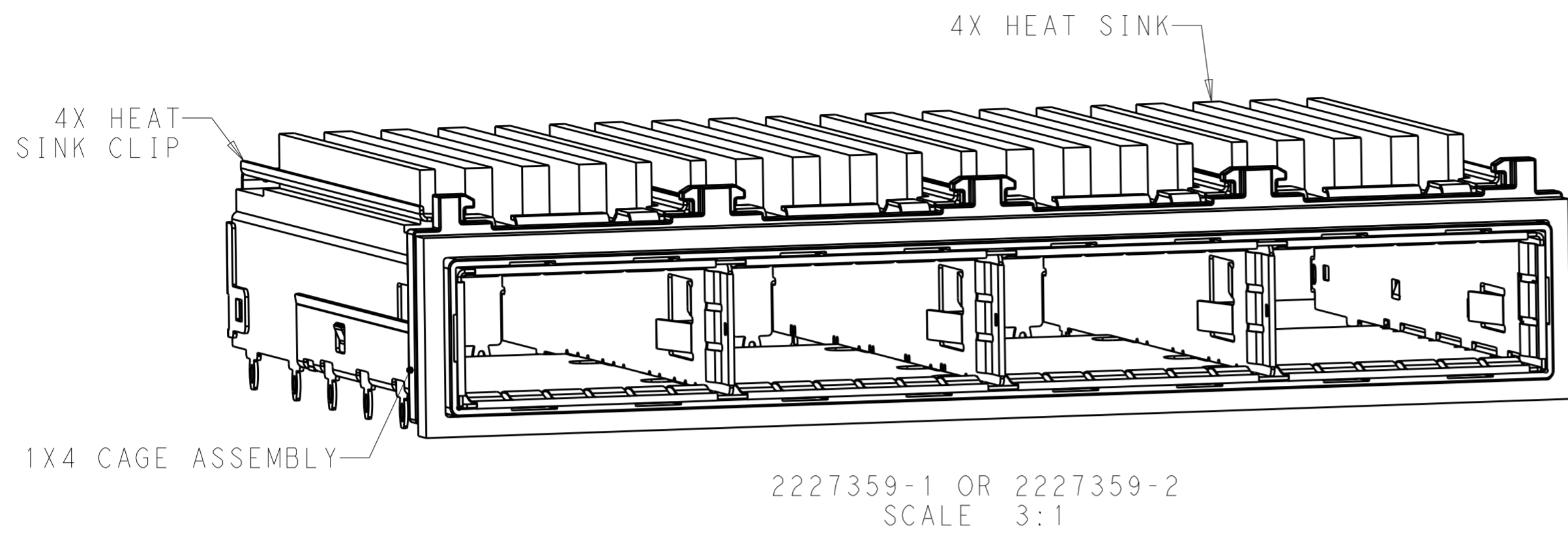

- COMPONENTS
 CAGE ASSEMBLY: NICKEL-SILVER ALLOY
 HEAT SINK: ALUMINUM/NICKEL PLATE
 HEAT SINK CLIP: STAINLESS STEEL
 EMI SPRING: COPPER ALLOY/TIN PLATE
 FRONT FLANGE: STAINLESS STEEL
 EMI GASKET: SILVER PLATED URETHANE
- REFERENCE APPLICATION SPECIFICATION 114-32046 FOR RECOMMENDED DRILL HOLE DIAMETER AND PLATING THICKNESS
- DATUM AND BASIC DIMENSION ESTABLISHED BY CUSTOMER
- WITH MODULE INSERTED IN CAGE
- HEAT SINKS, HEAT SINK CLIPS ARE SHIPPED ASSEMBLED ON CAGE

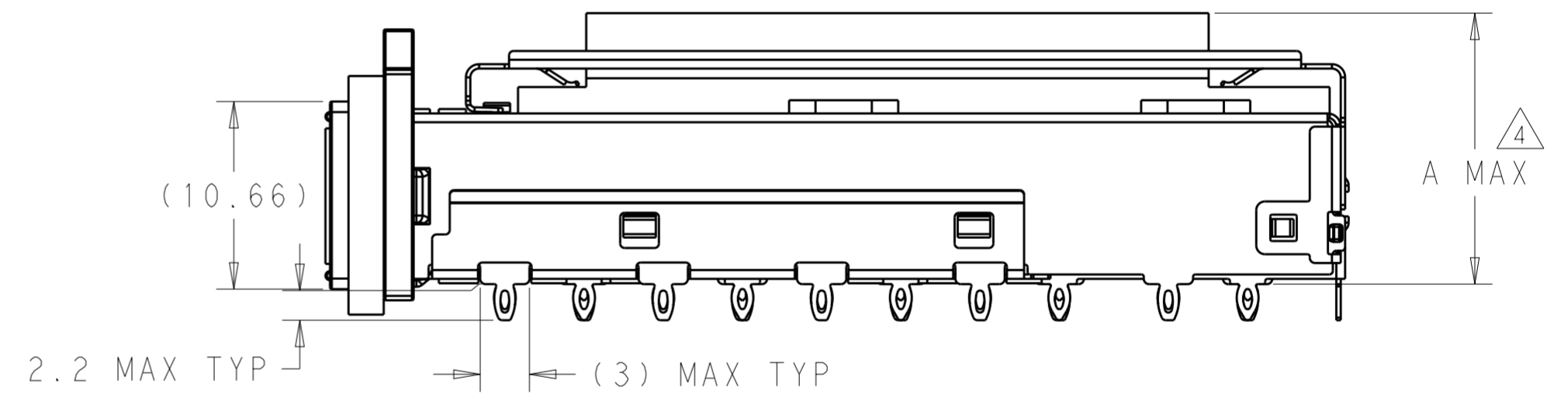
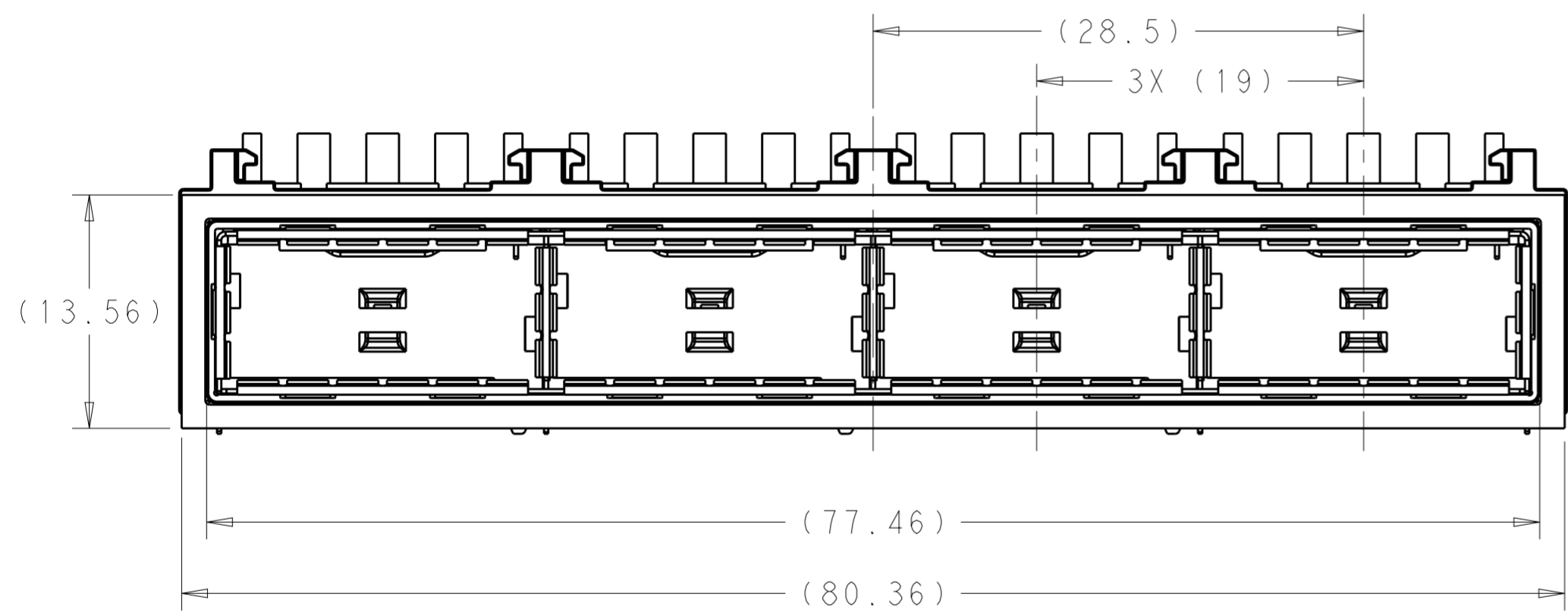

18.61	2227359-2
16.66	2227359-1
DIM A	PART NUMBER

THIS DRAWING IS A CONTROLLED DOCUMENT.

DIMENSIONS:	TOLERANCES UNLESS OTHERWISE SPECIFIED:	DWN	10OCT2012	TE Connectivity
mm	0 PLC ±	CHK	M.E. COWHER	
	1 PLC ±	APVD	M.D. MORRISON	
	2 PLC ±	APVD	M.D. MORRISON	
	3 PLC ±	PRODUCT SPEC	108-19428	NAME
	4 PLC ±	APPLICATION SPEC	-	RECEPTACLE ASSEMBLY, THRU BEZEL, 1X4, QSF28
	ANGLES ±	WEIGHT	-	SIZE
	FINISH	Customer Drawing	-	A200779
SEE NOTES	SEE NOTES	SCALE	3:1	DRAWING NO
		SHEET	1	C-2227359
		OF	5	RESTRICTED TO
		REV	A	-

THIS DRAWING IS UNPUBLISHED. RELEASED FOR PUBLICATION 20
 © COPYRIGHT 20 BY - ALL RIGHTS RESERVED.

LOC	DIST	REVISIONS					
GP	00	P	LTR	DESCRIPTION	DATE	DWN	APVD
		-		SEE SHEET 1			

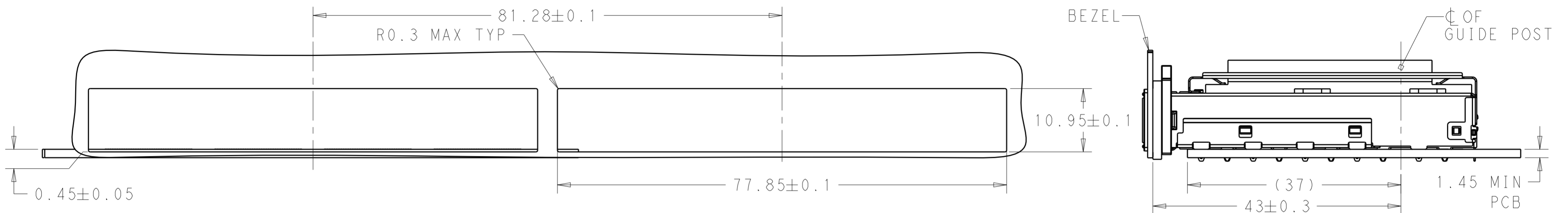

SHOWN IN SINGLE SIDE
 BEZEL/PCB CONFIGURATION
 SCALE 2:1

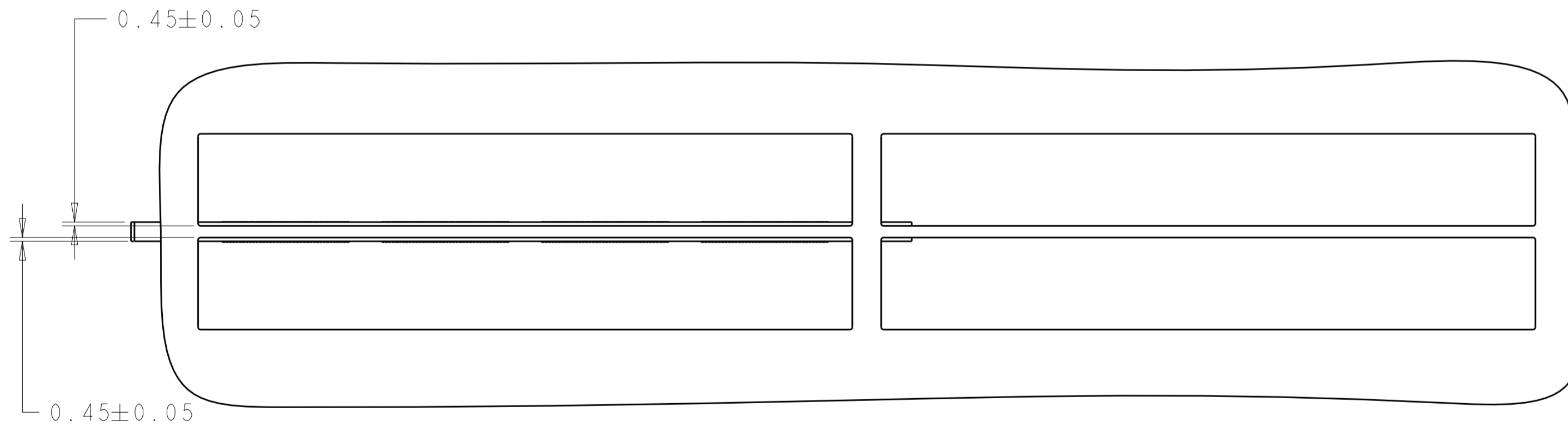

SHOWN IN BELLY TO BELLY
 BEZEL/PCB CONFIGURATION
 SAME AS ABOVE, EXCEPT AS SHOWN
 SCALE 2:1

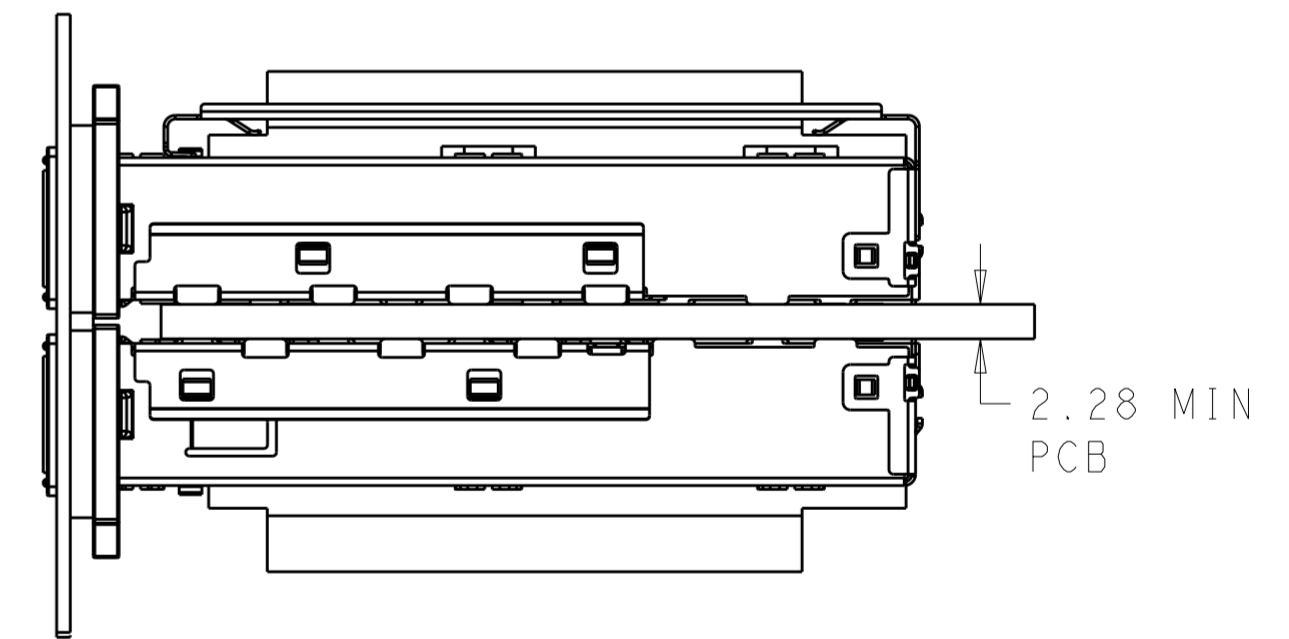

THIS DRAWING IS A CONTROLLED DOCUMENT.		DWN M. E. COWHER 10OCT2012	TE Connectivity	
DIMENSIONS: mm		CHK M. D. MORRISON 10OCT2012		
TOLERANCES UNLESS OTHERWISE SPECIFIED:		APVD M. D. MORRISON 10OCT2012	NAME RECEPTACLE ASSEMBLY, THRU BEZEL, 1X4, QSFP28	
0 PLC ±	1 PLC ±	PRODUCT SPEC 108-19428	SIZE A200779	DRAWING NO C-2227359
2 PLC ±	3 PLC ±	APPLICATION SPEC	RESTRICTED TO	
4 PLC ±	ANGLES ±	WEIGHT	-	
MATERIAL	FINISH	Customer Drawing	SCALE 3:1	SHEET 2 OF 5
SEE NOTES	SEE NOTES			REV A

THIS DRAWING IS UNPUBLISHED. RELEASED FOR PUBLICATION 20
 © COPYRIGHT 20 BY - ALL RIGHTS RESERVED.

LOC	DIST	REVISIONS					
GP	00	P	LTR	DESCRIPTION	DATE	DWN	APVD
		-		SEE SHEET 1			

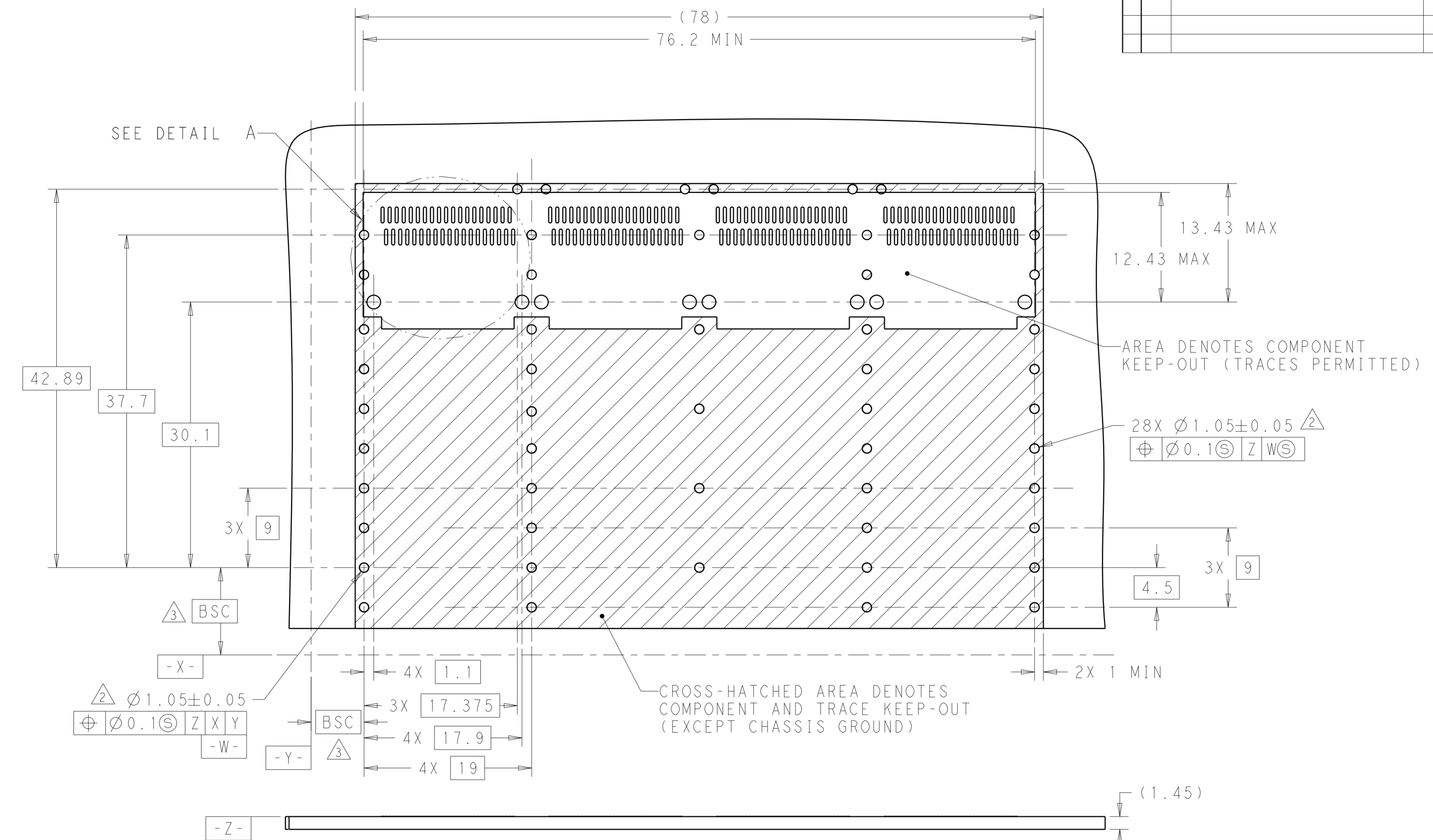

RECOMMENDED PCB LAYOUT
 SINGLE SIDE MOUNTED CONFIGURATION
 SCALE 3:1

THIS DRAWING IS A CONTROLLED DOCUMENT.		DWN M. E. COWHER 10OCT2012	TE Connectivity	
DIMENSIONS: mm		CHK M. D. MORRISON 10OCT2012		
TOLERANCES UNLESS OTHERWISE SPECIFIED:		APVD M. D. MORRISON 10OCT2012	NAME RECEPTACLE ASSEMBLY, THRU BEZEL, 1X4, QSF28	
0 PLC ± 1 PLC ± 2 PLC ± 3 PLC ± 4 PLC ± ANGLES ± FINISH ±		PRODUCT SPEC 108-19428	SIZE A200779	DRAWING NO C-2227359
MATERIAL SEE NOTES		WEIGHT -	RESTRICTED TO -	SCALE 3:1
SEE NOTES		Customer Drawing	SHEET 3 OF 5	REV A

THIS DRAWING IS UNPUBLISHED. RELEASED FOR PUBLICATION 20
 © COPYRIGHT 20 BY - ALL RIGHTS RESERVED.

LOC	DIST	REVISIONS					
GP	00	P	LTR	DESCRIPTION	DATE	DWN	APVD
		-		SEE SHEET 1			

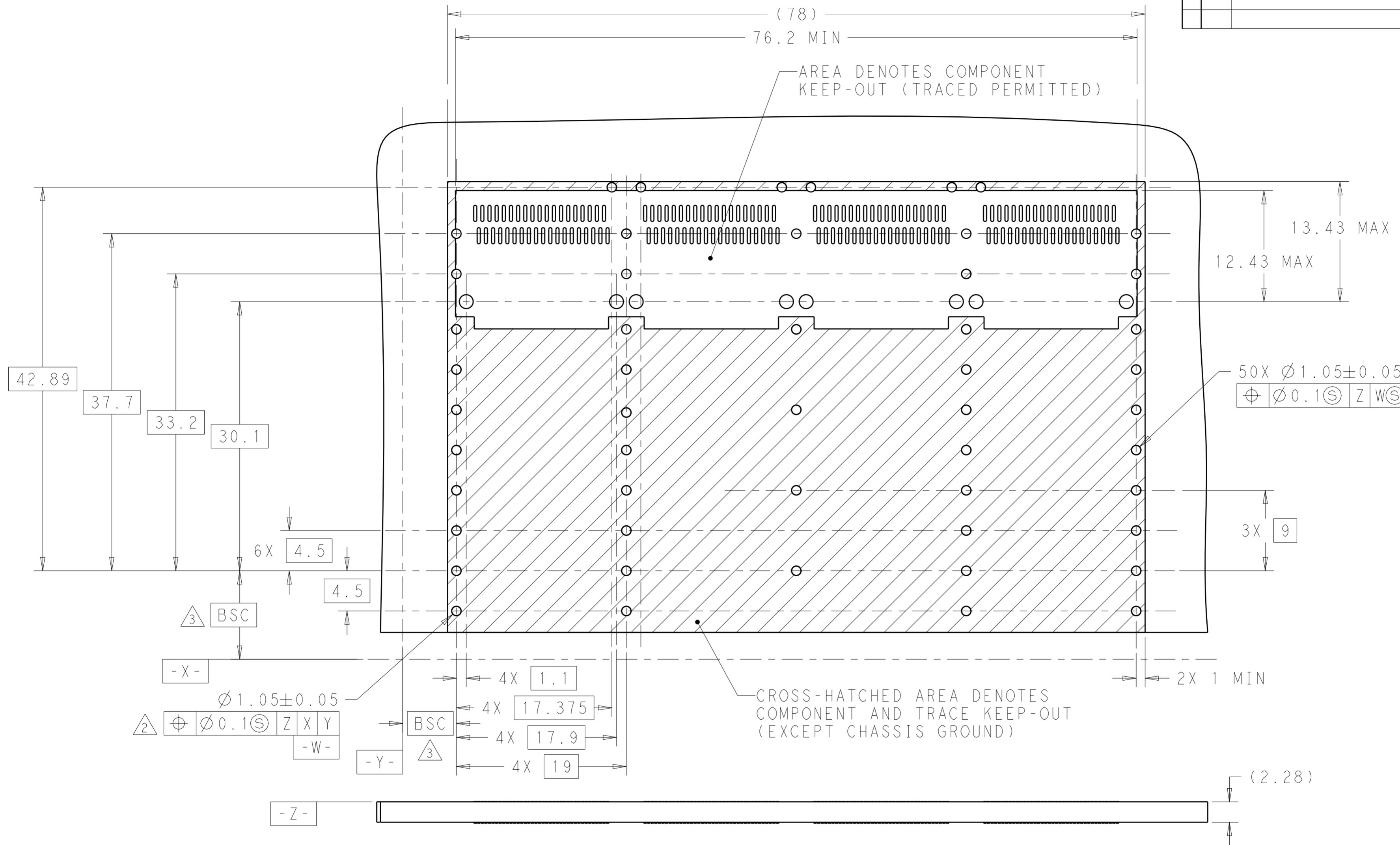

RECOMMENDED PCB LAYOUT
 BELLY TO BELLY MOUNTED CONFIGURATION
 SCALE 3:1

THIS DRAWING IS A CONTROLLED DOCUMENT.		DWN M. E. COWHER 10OCT2012	TE Connectivity	
DIMENSIONS: mm		CHK M. D. MORRISON 10OCT2012		
TOLERANCES UNLESS OTHERWISE SPECIFIED:		APVD M. D. MORRISON 10OCT2012	NAME RECEPTACLE ASSEMBLY, THRU BEZEL, 1X4, QSFP28	
0 PLC ± 1 PLC ± 2 PLC ± 3 PLC ± 4 PLC ± ANGLES ± FINISH ±		PRODUCT SPEC 108-19428	SIZE A200779	DRAWING NO C-2227359
MATERIAL SEE NOTES		WEIGHT -	RESTRICTED TO -	SCALE 3:1
SEE NOTES		Customer Drawing	SHEET 4 OF 5	REV A

THIS DRAWING IS UNPUBLISHED. RELEASED FOR PUBLICATION 20
 © COPYRIGHT 20 BY - ALL RIGHTS RESERVED.

LOC	DIST	REVISIONS					
GP	00	P	LTR	DESCRIPTION	DATE	DWN	APVD
		-		SEE SHEET 1	-	-	-

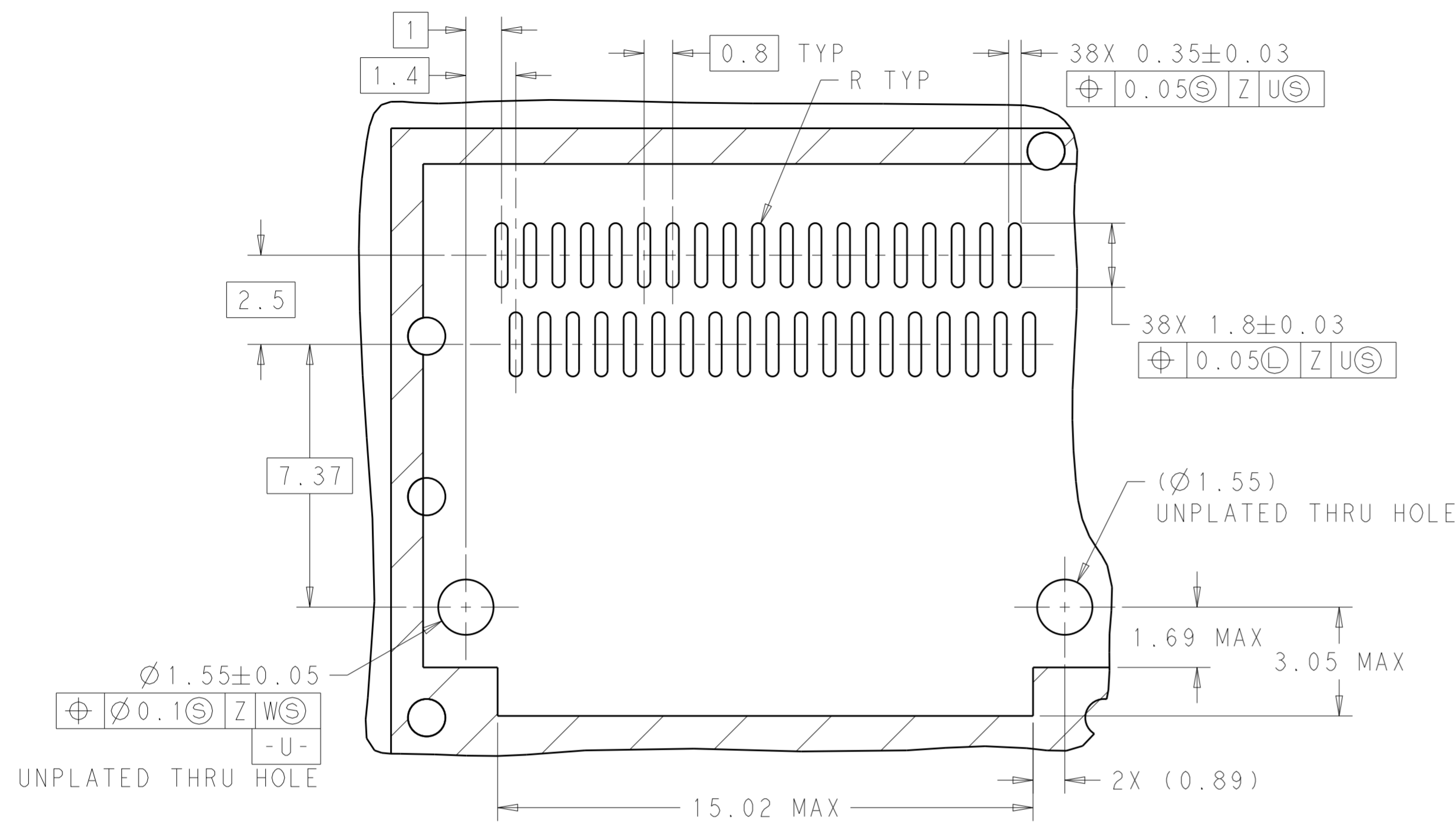

DETAIL A
 RECOMMENDED CONNECTOR LAYOUT
 (APPLIES TO ALL PCB LAYOUTS)
 4X INDIVIDUALLY
 SCALE 8:1

THIS DRAWING IS A CONTROLLED DOCUMENT.		DWN M. E. COWHER 10OCT2012	 TE Connectivity	
DIMENSIONS: mm		CHK M. D. MORRISON 10OCT2012		
TOLERANCES UNLESS OTHERWISE SPECIFIED:		APVD M. D. MORRISON 10OCT2012	NAME RECEPTACLE ASSEMBLY, THRU BEZEL, 1X4, QSFP28	
0 PLC ± 1 PLC ± 2 PLC ± 3 PLC ± 4 PLC ± ANGLES ± FINISH ±		PRODUCT SPEC 108-19428	SIZE A200779	DRAWING NO C-2227359
MATERIAL SEE NOTES		WEIGHT -	RESTRICTED TO -	SCALE 3:1
SEE NOTES		Customer Drawing	SHEET 5 OF 5	REV A