

- 1
- 2
- 3
- 4
- 5
- 6
- 7
- 8
- 9
- 10
- 11
- 12
- 13
- 14
- 15
- RH
-

MATERIAL

High-strength, reinforced phenolic based (PF) Duroplast, black colour, glossy finish.

RING

Matte anodised aluminium.
(ELESA Original design - Reg. U.S. Pat. & TM Off.)

STANDARD EXECUTION

Safety coupling bushing with "Pull-coupling" assembly GN 000.5 hardened steel with ground sliding surfaces, reamed assembly hole and keyway in compliance with DIN 6885/2 tolerance P9.
Revolving handle I.301+x in Duroplast.

SPECIAL EXECUTIONS ON REQUEST

These handwheels can be supplied with "Push-coupling". By inserting the bushing the other way round, the handwheel operates opposite to the standard way.

INSTRUCTIONS OF USE

Safety handwheels are designed in accordance with accident prevention rules: in case of push or accidental pressure when the machine is operating, the handwheel is disengaged and is in the rest position. Only by "Pulling" the handwheel parallel to the axis can the shaft operate: the two toothed elements inside the bushing fit into each other in order to couple the handwheel to the shaft. The handwheel returns automatically to its rest position when it is released after the operation.

ERGONOMY

The rim with internal rear scallops makes the grip and the manoeuvre of the handwheel easier.



ELESA Original design

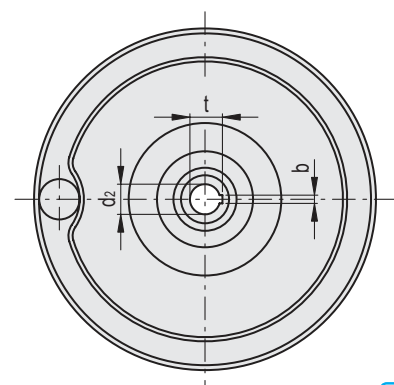
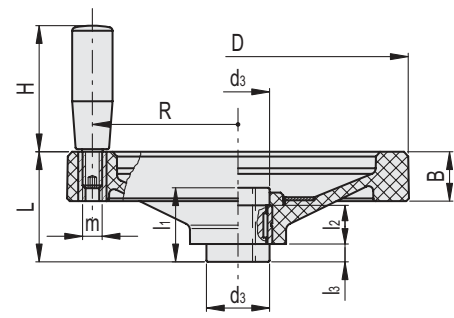
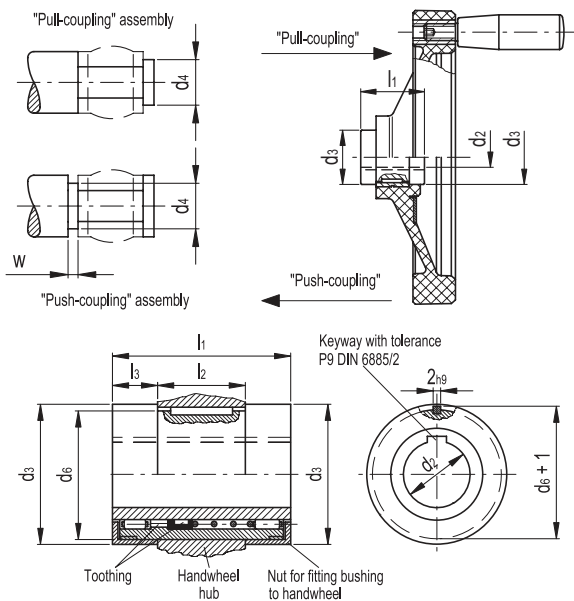

Conversion Table
1 mm = 0.039 inch

METRIC

Code	Description	D	d2 H7	L	B	d3	d4 max	d6	l1	l2 ±0.2	l3	H	m	R	wmin	t	b	Δ
73728	VDN.125 FP+I+ST12	125	12	58	28	29	17	25 -0.05	42	18	12	65	M8	50	4	13.1	4	465
73738	VDN.150 FP+I+ST14	150	14	67	30	33	21	29 -0.05	48	20	14	65	M8	62	4	15.3	5	650
73748	VDN.175 FP+I+ST14	175	14	69	32	33	21	29 -0.05	48	20	14	80	M10	72.5	4	15.3	5	810
73758	VDN.200 FP+I+ST18	200	18	72	32	39	26	35 -0.05	50	24	13	90	M10	82	4	19.7	6	1220
73778	VDN.250 FP+I+ST22	249	22	82	36	46	30	41 -0.05	54	28	13	90	M10	106	4	23.7	6	1670

Operating elements