

REV.	DESCRIPTION	DATE
A	New Drawing	2010/02/08

LTR	Part Name	Material	Description	QTY
1	Housing	Nylon UL94V-0	260°C for 10 Seconds . Initial : 1000M Ohms Min. After Test : 500M Ohms Min.	1
2	Contact	Brass	Current Rating : 3.0A Initial : 20m Ohms Max. After Test : 40m Ohms Max.	xx

Temperature Rating : -40°C ~ +125°C .  
Dielectric Withstanding Voltage : 1000V AC/Min .

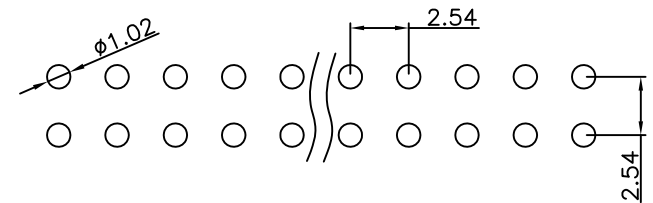

P.C.B LAYOUT

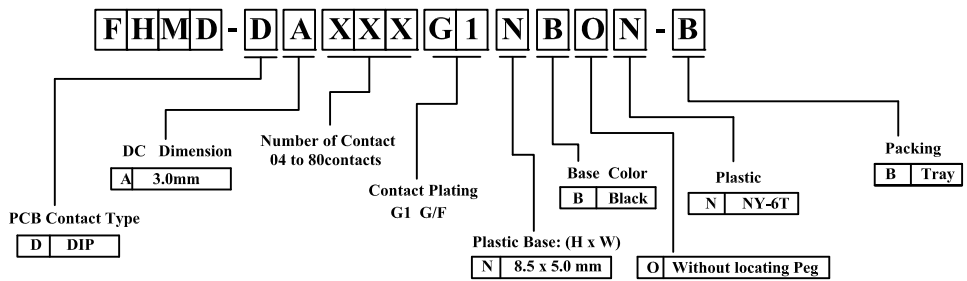

RoHS compliant

**Superior Tech Co., Ltd.**

General Tolerance		TITLE		
X. ± 0.5	DRAWN	2.54x2.54mm Female Header Dual Row DIP Type		DATE
.X ± 0.3		Zhanghonglan	02-08-10'	
.XX ± 0.2	CHECK	DATE	NO.	
.XXX ± 0.1	APPROVED	DATE	PART NO.	
Angle ± 5°			CUSTOMER NO.	

REV.	UNIT	SCALE	
A	mm	3:1	

REV.	DESCRIPTION	DATE
A	New Drawing	2022/05/30

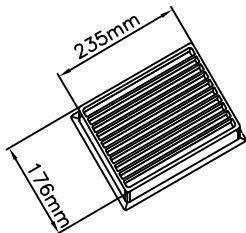

Blister box cover

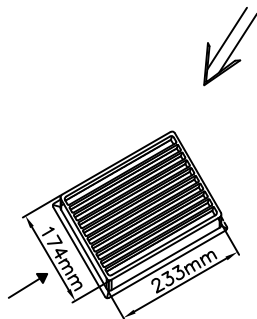

Blister box bottom

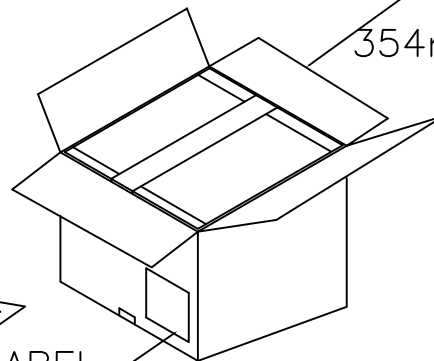

BOX DIMENSIONS:  
354mm X 354mm X 330mm

RoHS compliant

Packing instructions

PIN NO.	Each box (PCS)	Each case (PCS)
2*3Pin	520pcs	18720pcs
2*4Pin	400pcs	14400pcs
2*5Pin	320pcs	11520pcs
2*10Pin	160pcs	5760pcs

19 PCS Vacuum disc

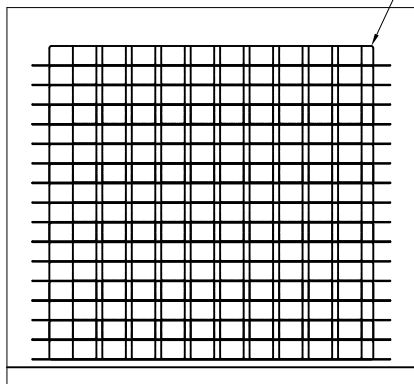

finished product

**Superior Tech Co., Ltd.**

General Tolerance		TITLE	FHMD-DAXXXG1NBON-B_Packing	
X. ± 0.5		DRAWN	DATE	NO.
.X ± 0.3		Tom	2022/05/30	002
.XX ± 0.2		CHECK	DATE	PART NO.
.XXX ± 0.1		APPROVED	DATE	FHMD-DAXXXG1NBON-B
Angle	± 5°			CUSTOMER NO.
				DK

REV.	UNIT	SCALE	
A	mm	1:10	