



Sensor Board Guide for the VEML3328

INTRODUCTION

The VEML3328 sensor board is intended to be used in conjunction with Vishay’s SensorXplorer demonstration kit, or as a standalone unit, to evaluate the capabilities of the VEML3328 color sensor.

SensorXplorer™

The SensorXplorer (Fig. 1) is a demonstration kit designed to help evaluate Vishay’s digital sensors featured on Vishay’s sensor boards. These boards, along with their respective software modules, can be used to demonstrate and test each sensor’s functionalities, allowing the user to quickly understand how various settings affect the sensor’s results. The SensorXplorer board includes an USB to I²C interface chip, a 3.3 V regulator, several indicator LEDs, as well as multiple GPIOs to control the functionality of each board and allow data to be read and displayed on a PC. To get an overview of available sensor boards, as well as to download the software modules and board design files, please visit: www.vishay.com/optoelectronics/SensorXplorer. Here you will also find a link next to each board showing its availability at each of our distributors.

Complete information about the SensorXplorer kit as well as all available sensor boards is available at www.vishay.com/optoelectronics/SensorXplorer. The same page also allows you to check inventory of SensorXplorer kits and Vishay sensor boards at our distributors.

The SensorXplorer installation guide is available for download from the following link: www.vishay.com/doc?84922

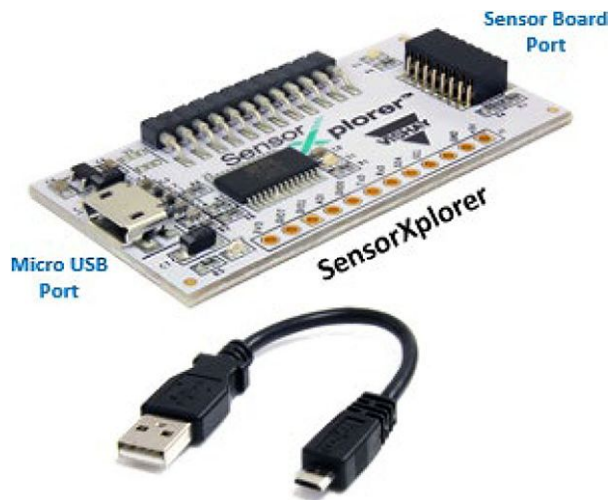

Fig. 1 - SensorXplorer

USING THE SENSOR BOARD WITH THE SensorXplorer

Following the instructions in the SensorXplorer installation guide, install the SensorXplorer software on your PC, then connect the SensorXplorer evaluation board to your PC and the Vishay sensor board.

The respective demo board software module can then be downloaded from: www.vishay.com/landingpage/SensorXplorer/

Once the module is unzipped the software can be run without the need for further installation.

You are now ready to explore the sensor and its different settings to see how they will work in your application.

HOW TO USE THE DEMOSOFTWARE

Tabs to switch between the various functions of the software module
 Graph plots the results of the active measurement
 Controls to change the settings of the color sensor
 Displays the measurement results of the different channels
 Turn on / off the assembled external white, RGB and infrared LEDs
 Controls to active measurements and clear the graph

Fig. 2 - Demosoftware GUI

USING THE SENSOR BOARD FOR ITSELF

If you want to use the sensor board within your own application and with own self-written software for communication with the sensor you just need to connect the board to power (3.3 V, GND) and the I²C lines (SDA, SCL) as you can see in the figure below.

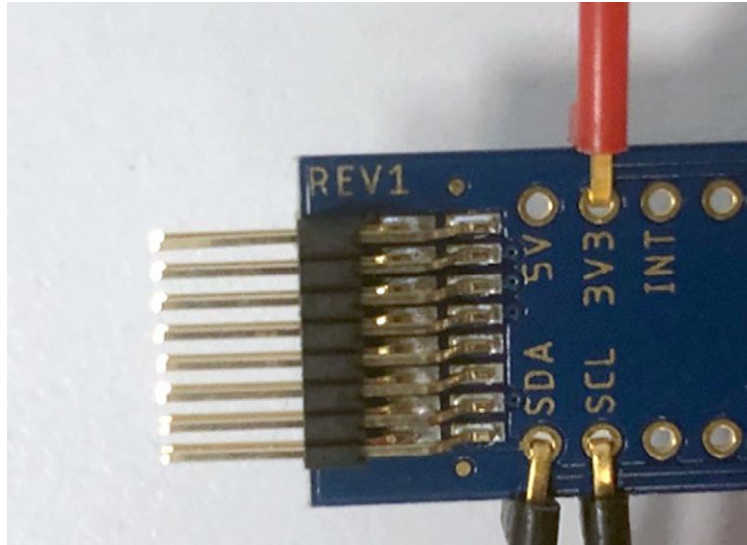

Fig. 3 - Connection of the Sensor Board (power supply and I²C lines)

SCHEMATIC OF THE VEML3328 SENSOR BOARD

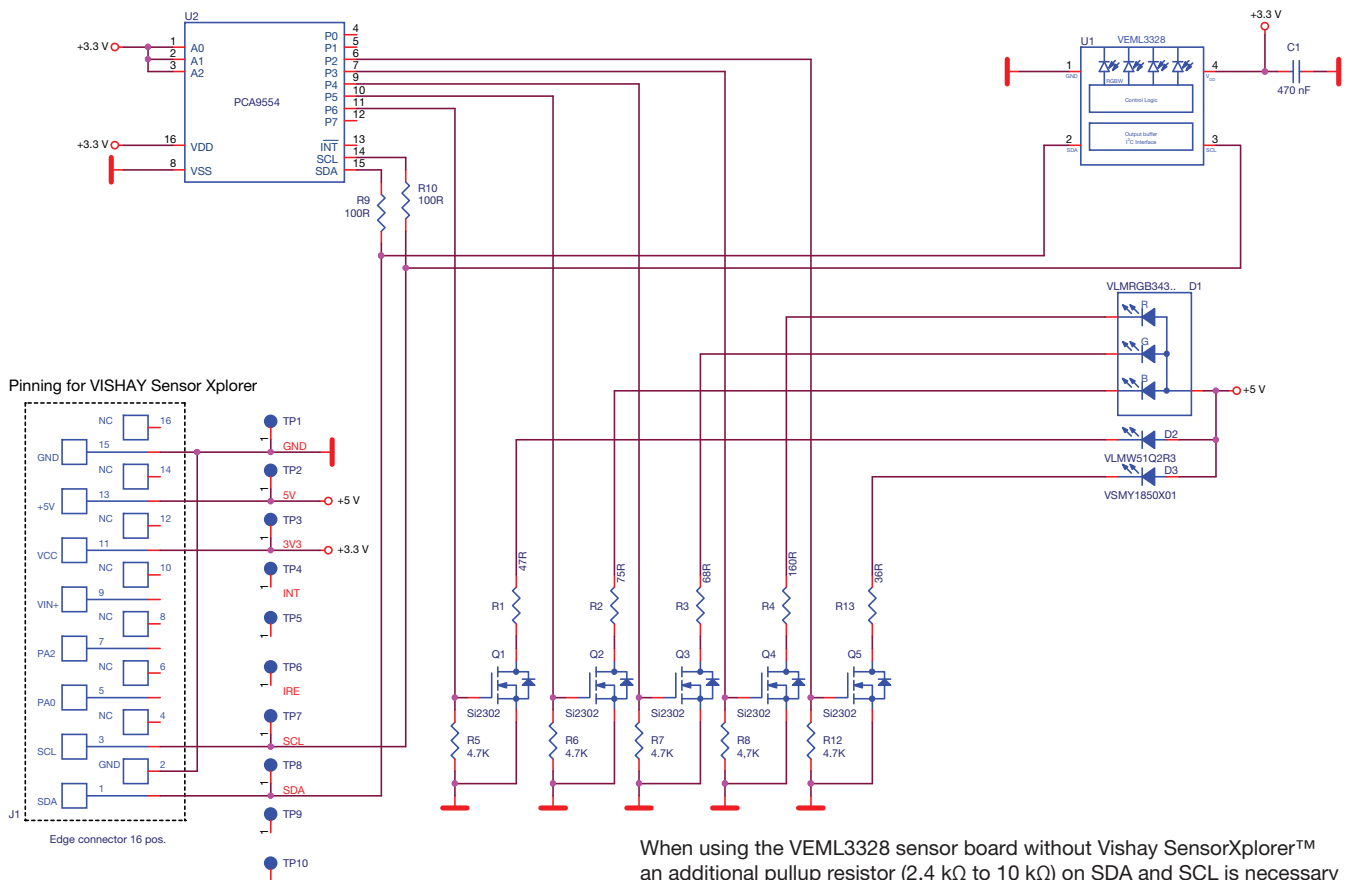
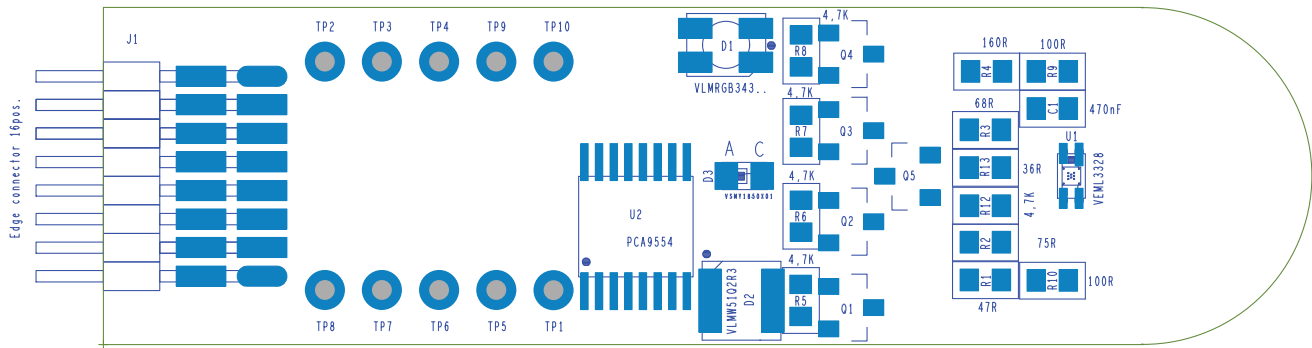

Fig. 4 - Schematic of the VEML3328-SB, Rev. 3

ASSEMBLY OF THE VEML3328 SENSOR BOARD

VEML3328 sensor board, rev. 3.0



Assembly top

BILL OF MATERIALS					
ITEM	QUANTITY	REFERENCE	COMPONENT CLASS	VALUE	PACKAGE
1	1	C1	Capacitor NP	470 nF	SMC0603
2	1	D1	LED RGB	VLMRGB343	PLCC-4
3	1	D2	LED white	VLMW51Q2R3	PLCC-2 plus
3	1	D3	LED IR 850 nm	VSMY1850X01	SMD0805
4	1	R1	Resistor	47R	SMR0603
5	1	R2	Resistor	75R	SMR0603
6	1	R3	Resistor	68R	SMR0603
7	1	R4	Resistor	160R	SMR0603
8	1	R5	Resistor	4.7K	SMR0603
9	1	R6	Resistor	4.7K	SMR0603
10	1	R7	Resistor	4.7K	SMR0603
11	1	R8	Resistor	4.7K	SMR0603
12	1	R9	Resistor	100R	SMR0603
13	1	R10	Resistor	100R	SMR0603
11	1	R12	Resistor	4.7K	SMR0603
11	1	R13	Resistor	36R	SMR0603
14	1	Q1	Transistor	Si2302	SMSOT23GSD
15	1	Q2	Transistor	Si2302	SMSOT23GSD
16	1	Q3	Transistor	Si2302	SMSOT23GSD
17	1	Q4	Transistor	Si2302	SMSOT23GSD
17	1	Q5	Transistor	Si2302	SMSOT23GSD
19	1	U1	Sensor	VEML3328	SMD
18	1	U2	IC	PCA9554	TSSOP16
20	1	J1	Edge connector	2 x 8 pos.	SMD header strip