



A421 Series Standard Electronic Temperature Controls

Installation Instructions

A421ABC-x, A421AEC-x,
A421GBF-x, A421GEF-x

Part No. 24-7664-3019, Rev. B
Issued November 6, 2015

Refer to the [QuickLIT website](http://www.QuickLIT.com) for the most up-to-date version of this document.

Applications

IMPORTANT: Use this A421 Series Electronic Temperature Control only as an operating control. Where failure or malfunction of the A421 control could lead to personal injury or property damage to the controlled equipment or other property, additional precautions must be designed into the control system. Incorporate and maintain other devices, such as supervisory or alarm systems or safety or limit controls, intended to warn of or protect against failure or malfunction of the A421 control.

IMPORTANT: Utiliser CE A421 Series Electronic Temperature Control uniquement en tant que dispositif de régulation. Lorsqu'une défaillance ou un dysfonctionnement du A421 control risque de provoquer des blessures ou d'endommager l'équipement contrôlé ou un autre équipement, la conception du système de contrôle doit intégrer des dispositifs de protection supplémentaires. Veiller dans ce cas à intégrer de façon permanente d'autres dispositifs, tels que des systèmes de supervision ou d'alarme, ou des dispositifs de sécurité ou de limitation, ayant une fonction d'avertissement ou de protection en cas de défaillance ou de dysfonctionnement du A421 control.

The A421 Series Electronic Temperature Controls are single-stage, electronic temperature controls with a single-pole, double-throw (SPDT) output relay.

A421 controls feature a backlit LCD with adjustable brightness and three-button touchpad interface that can be set up to restrict user adjustments. An LED indicates the output relay's On/Off status.

A421 controls have simple On and Off temperature settings for heating or cooling, an adjustable anti-short cycle delay, temperature setback, and sensor offset capability. The temperature control range is 40 to 212°F or -40 to 100°C.

The A421 controls are available either in Type 1 (NEMA), IP20 (CE), high-impact plastic enclosures suitable for surface or DIN rail mounting (Figure 1) or in Type 4X (NEMA), IP66 (CE) watertight, corrosion resistant surface mount enclosures (Figure 2).

Dimensions

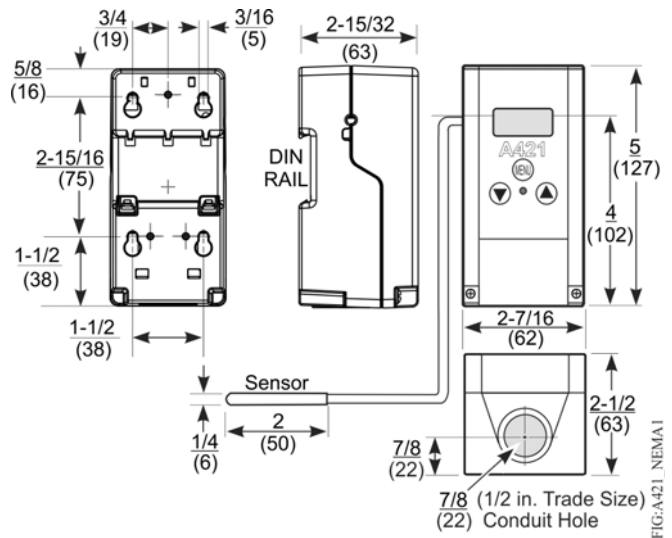

Figure 1: A421 Control with Type 1 (NEMA), IP20 Enclosure Dimensions, in. (mm)

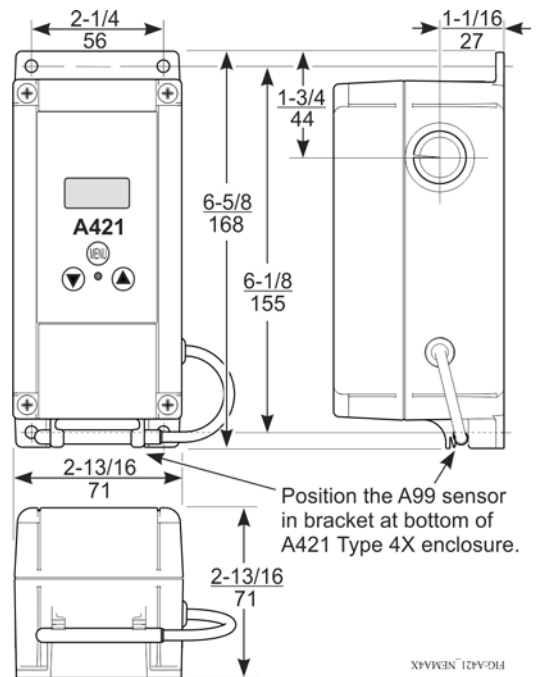

Figure 2: A421 Control with Type 4X (NEMA), IP66 Enclosure Dimensions, in. (mm)

Parts Included

Each A421 Control includes a Johnson Controls/ PENN® A99 Series temperature sensor. See [A99 Series Temperature Sensors](#), [Wiring](#), and [Technical Specifications](#) for more information about A99 sensors.

A99 Series Temperature Sensors

The A421 controls require an A99 sensor, and each A421 control includes an A99 sensor. Any A99 Series sensor works with the A421 Series controls. Do **not** replace an A99 Series sensor with any other brand, series, or type of temperature sensor. See [Ordering Information](#) for available A99 Series sensor models.

The sensor leads may be extended in the field. See Table 1 for recommended wire sizes and lengths. On long sensor cable runs, use shielded cable to reduce Electro-Magnetic Interference (EMI). Observe EMI best practices when routing sensor leads.

The A99 Series sensors are moisture tolerant and splash resistant, but do **not** completely immerse the A99 sensor in water or any other liquid. Immersing the sensor can allow liquid to enter the sensor probe where the stainless steel tube meets the wire cable and result in sensor failure, which voids any warranty.

In applications where the sensor may be exposed to a lot of moisture, splashing, or rain, we recommend mounting the sensor in a vertical position with the cable at the bottom routed downward to allow moisture to drain away from the stainless steel probe. Use a suitable bulb well for complete fluid immersion applications. See [Ordering Information](#) for a recommended bulb well.

The A99 Series sensors are positive temperature coefficient (PTC) sensors. To test an A99 sensor, disconnect the sensor from the control and measure the resistance between the sensor leads:

- When the temperature at the sensor is 77°F (25°C), the resistance should be 1,035 ohms.
- When the temperature at the sensor is 32°F (0°C), the resistance should be 855 ohms.

See [Troubleshooting](#) for more information.

When an A99 sensor is connected to a standard A421 control, the range of usable values is restricted by the control to -40 to 212°F (-40 to 100°C).

See [Wiring](#), [Technical Specifications](#), and refer to the *A99B Series Temperature Sensors Product/Technical Bulletin (LIT-125186)* for more information regarding A99 Series sensors.

Mounting

Observe the following guidelines when locating and mounting an A421 control:

- Ensure that the mounting surface can support the control, DIN rail, mounting hardware, and any (user-supplied) panel or enclosure.
- Mount the control in a vertical, upright orientation wherever possible. DIN rail mounting is strongly recommended for Type 1 controls.
- In direct-mount applications, mount the control on a flat and even surface.

Mount the control in a location free of corrosive vapors and observe the ambient operating conditions listed in [Technical Specifications](#) for both the A421 control and the A99 sensor.

- Allow sufficient space for connecting and routing wires, viewing the LCD, and using the touchpad.
- Do not mount the control on surfaces that are prone to vibration or in a location where high-voltage relays, motor starters, other sources of electromagnetic emissions, or strong radio frequency may cause interference.
- Do not install the control in an airtight enclosure.
- Do not install heat generating devices with the control in an enclosure that may cause the ambient temperature to exceed 150°F (66°C).

To mount a Type 1/IP20 control on DIN rail:

1. Provide a section of 35 mm DIN rail that is longer than the control width, and mount the DIN rail in a suitable location using appropriate mounting hardware.
2. Clip the control module on the rail, position the module's upper DIN rail clips on the top rail, and gently snap the lower clips on to the bottom of the rail.

To direct-mount a Type 1/IP20 control to a wall or other flat surface using the four keyhole slots:

1. Remove the enclosure cover, place the control vertically against the wall surface in a suitable location, and mark the keyhole slot locations on the mounting surface.
2. Install appropriate screws or fasteners, leaving the screw heads approximately one or two turns away from flush to the mounting surface.

3. Position the control mounting slots over the screw heads, and then carefully tighten the mounting screws to secure the control to the surface.
4. When mounting the control on an uneven surface, use shims to mount the control evenly on the surface.

Additional Guidelines for Mounting Type 4X/IP66 Controls

The Type 4X models may be mounted to flat vertical surfaces using the four holes at the enclosure corners. Place the control against a flat wall surface in a suitable location, and mark the mounting screw hole locations on the mounting surface. Use appropriate screws and shims to mount the control evenly on the surface.

On Type 4X models, select the knockout to be removed. Place a screwdriver blade on the knockout near the edge. Apply a sharp blow to the screwdriver handle to loosen the knockout. Be careful not to damage the control’s interior components.

An additional low-voltage, two-wire cable is required to operate the A421 control’s temperature setback (BIN) function. On Type 4X/IP66 enclosures, you must install a suitable watertight fitting in an available knockout to pass the two-wire cable through the enclosure wall.

The control enclosure base on the Type 4X/IP66 models can be easily rotated 180° relative to the control enclosure cover and LCD, allowing you to bring the electrical connection to either the top or bottom of the mounted control.

Note: Do not twist the wiring harness between the enclosure base and cover more than 180°.

Wiring



WARNING: Risk of Electric Shock.

Disconnect or isolate all power supplies before making electrical connections. More than one disconnection or isolation may be required to completely de-energize equipment. Contact with components carrying hazardous voltage can cause electric shock and may result in severe personal injury or death.

AVERTISSEMENT : Risque de décharge électrique.

Débrancher ou isoler toute alimentation avant de réaliser un raccordement électrique. Plusieurs isolations et débranchements sont peut-être nécessaires pour -couper entièrement l'alimentation de l'équipement. Tout contact avec des composants porteurs de tensions dangereuses risque d'entraîner une décharge électrique et de provoquer des blessures graves, voire mortelles.

IMPORTANT: Use copper conductors only. Make all wiring in accordance with local, national, and regional regulations.

IMPORTANT: Do not exceed the A421 control’s electrical ratings. Exceeding the electrical ratings can result in permanent damage to the control and void any warranty.

IMPORTANT: Run all low-voltage wiring and cables separate from all high-voltage wiring. Shielded cable is strongly recommended for input (sensor) cables that are exposed to high electromagnetic or radio frequency noise.

IMPORTANT: Electrostatic discharge can damage A421 controls. Use proper Electrostatic Discharge (ESD) precautions during installation and servicing to avoid damaging A421 controls.

IMPORTANT: Do not connect supply power to the A421 controls before checking all wire connections. Short circuits or improperly connected wires can result in damage to the modules and void any warranty.

IMPORTANT: When connecting an A99 sensor with a shielded cable to an A421 Control, connect the cable shield drain lead to the COM (common) terminal on the sensor and binary input terminal block (TB3). Do not connect the shield at any other point along the cable, and isolate and insulate the shield along the entire length of the sensor cable. Connecting a cable shield at more than one point can enable transient currents to flow through the sensor cable shield, which can cause erratic control operation.

Observe the wire size restrictions listed in Table 2 on page 5 and the Electrical Ratings listed in *Technical Specifications*.

Observe the following guidelines, procedures, and illustrations when wiring an A421 Series control and A99 Series sensor.

- Select only the A99 sensors that are designed to operate in the ambient operating range that your A421 control is intended to monitor and control as shown in Table 7. See *Technical Specifications* for more information.
- Keep the sensor leads as short as possible in your application. The additional resistance in long sensor cables creates an offset between the actual temperature and the displayed temperature. See Table 1 when extending sensor leads.
- A99 sensors are not polarity specific. Either lead can be connected to the SEN or COM terminals.

- We recommend 22 AWG, stranded, twisted-pair cable with a shield for extending sensor cable runs.

Table 1: Maximum Recommended Sensor Cable Lengths and Wire Sizes

Wire Gauge	Maximum Sensor Cable Length ¹ , Feet (Meters)
16 AWG	500 (150)
18 AWG	300 (100)
20 AWG	200 (60)
22 AWG	125 (40)

1. At the listed maximum cable lengths, there is less than 1F° (0.6C°) error between the temperature sensed at the A99 sensor and the temperature displayed on the LCD.

TB2 Terminal Block and SPDT Relay Output

The terminals (LC, LNO, and LNC) on the TB2 terminal block are connected to a SPDT dry-contact relay in the A421 control (Figure 3). The control does not provide any internal power to the TB2 terminals or relay contacts. The A421 control simply energizes and de-energizes the relay to open and close the contacts based on the On/OFF temperature values.

Relay De-energized (Off) = LC open to LNO (as shown in Figure 3) and the relay status LED is off

Relay Energized (On) = LC closed to LNO and the relay status LED is on

Figure 4 shows how to wire the A421 control to use the same power source that powers the controlled equipment to also power the A421 control.

TB2 Terminal Block
Showing Internal SPDT Relay
(Normally Closed Position:
Green Relay Status LED is off.)

A power source for the controlled equipment must be connected to LC.
In typical applications, LNO supplies power (from LC) to the controlled equipment when the relay is energized.

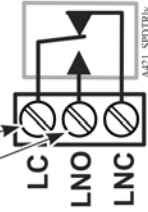

You can also provide an independent power source for the A421 control on the TB1 terminals and then wire the TB2 relay terminals to a separate power source for switching and powering the controlled equipment circuit.

Figure 3: TB2 Terminal Block Showing Connections to the Internal SPDT Relay

Table 2: A421 Control Wiring Terminals and Wire Size Information

Terminal Block	Label	Description, Function, and Requirements	Recommended Wire Sizes
TB1 24 VAC Models	LN	Low-Voltage 24 VAC Control Power (Common): Connect the 24 VAC supply power to operate the control.	28 AWG to 12 AWG 0.08 mm ² to 4.0 mm ²
	24V	Low-Voltage 24 VAC Control Power (Hot): Connect 24 VAC supply power to operate the control (via jumper from LC in Figure 4).	
TB1 120/240 VAC Models	LN	Line-Voltage Power Source (Common): Connect the neutral wire for 120 VAC supply power applications. Connect the L1 supply power lead for all 208/240 VAC supply power applications.	28 AWG to 12 AWG 0.08 mm ² to 4.0 mm ²
	120V	Line-Voltage 120 VAC Control Power (Hot): Connect the 120 VAC supply power (hot) for 120 VAC supply power applications (via jumper from LC in Figure 4).	
	240V	Line-Voltage 240 VAC Control Power (L2) Terminal: Connect the L2 supply power connection for 208/240 VAC supply power applications (via jumper from LC in Figure 4).	

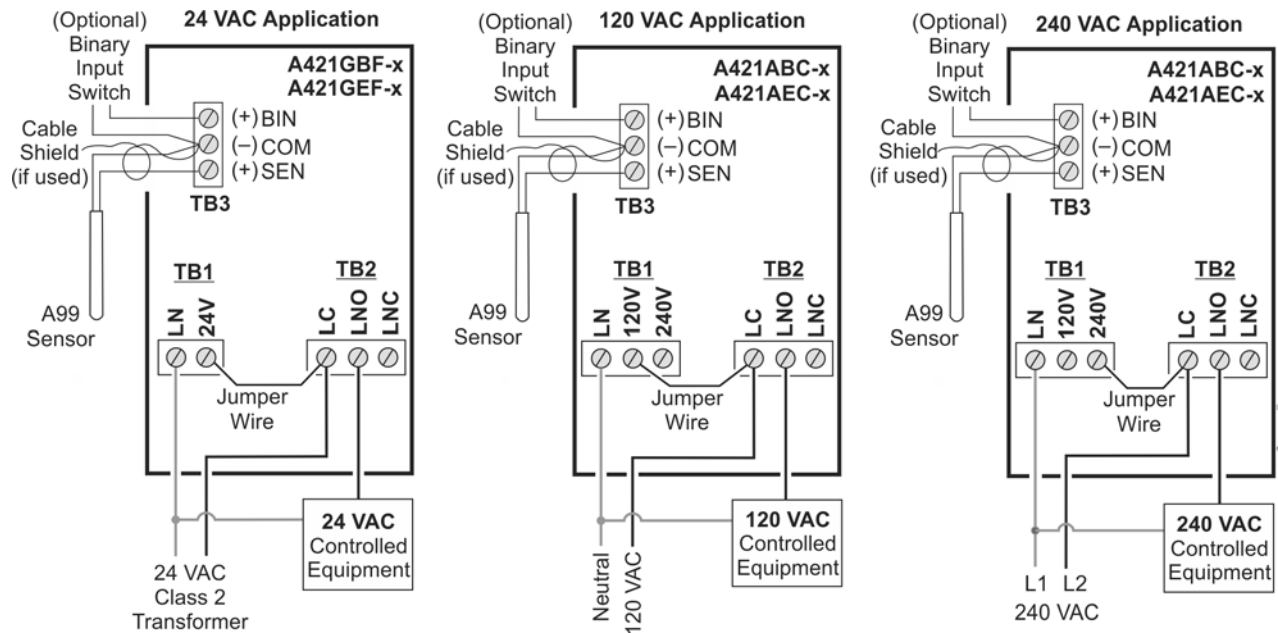

Figure 4: Wiring the A421 Series Controls Using the Same Power Source to Power the Control Operation and Power the Controlled Equipment

Table 2: A421 Control Wiring Terminals and Wire Size Information

Terminal Block	Label	Description, Function, and Requirements	Recommended Wire Sizes
TB2	LC	Line-Voltage SPDT Relay Common Contact: Connect power supply to power the controlled load. Connect 24 VAC (hot) for 24 VAC applications. Connect 120 VAC (hot) for 120 VAC applications. Connect L2 for 208/240 VAC applications.	28 AWG to 12 AWG 0.08 mm ² to 4.0 mm ²
	LNO	Line-Voltage SPDT Relay Normally Open Contact: Connects controlled equipment to the Line-Voltage Normally Open (LNO) contact on the SPDT relay. When LC is closed to LNO, the relay is energized and the green LED is on. The LNO terminal typically provides power to the controlled equipment in both cooling and heating applications.	
	LNC	Line-Voltage SPDT Relay Normally Closed Contact: Connects controlled equipment to the Line-Voltage Normally Closed (LNC) contact on the SPDT relay. When LC is closed to LNC, the relay is de-energized and the green LED is off. The LNC terminal is not typically wired to the controlled equipment.	
TB3	BIN	Detects a switch closure between the BIN and COM terminals and enables the selected temperature setback (tSb) value.	22 AWG (0.34 mm ²) stranded, shielded cable recommended
	COM	Connects low-voltage common from the sensor and binary input.	
	SEN	Connects low-voltage input signal wire from control sensors.	

Replacing an A419 Control with an A421 Control:
Terminal Locations and Labels

The A421 Series Electronic Temperature Controls are the next generation of the A419 Series Electronic Temperature Controls.

If you need to replace an A419 control with an A421 control, be sure to note that wiring terminals on the TB1 and TB2 terminal blocks on A421 controls are in different positions and have different terminal labels from the wiring terminals on the A419 controls. Table 3 provides a cross-reference for matching the terminal labels on A419 controls to the terminal labels on A421 controls.

Note: The low-voltage signal terminals on the TB3 terminal block are labeled the same on both A419 controls and A421 controls.

See Figure 4 for terminal block and terminal positions on the A421 control.

Table 3: A419 and A421 Wiring Terminal Labels

Terminal Block	A419 Terminal Label	A421 Terminal Label
TB1 (24 VAC)	T1	LN
	T2	24V
TB1 (120/240 VAC)	120	120V
	240	240V
	AC COM	LN
TB2 (All Voltages)	C	LC
	NO	LNO
	NC	LNC

Setup and Adjustments

Front Panel

The front panel of the A421 Series Electronic Temperature Control has a simple LCD and a three-button user interface (Figure 5).

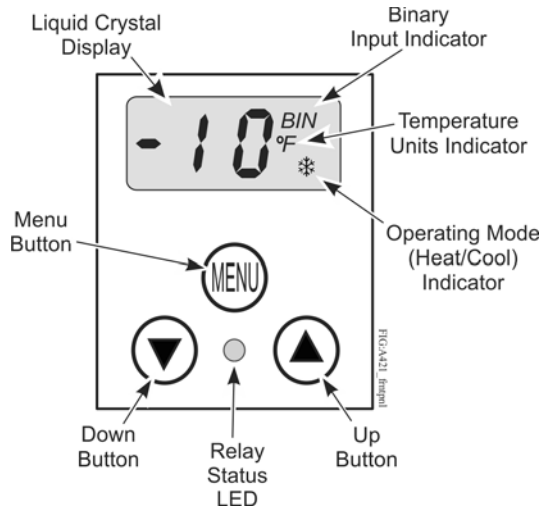

Figure 5: A421 Control Front Panel with LCD and Three-Button User Interface

Liquid Crystal Display

The A421 Series Control has a backlit LCD screen (Figure 5). The LCD brightness is adjustable. During normal operation, the LCD displays the Main screen, which provides following information:

- the temperature sensed at the A99 sensor
- the selected temperature units (°F or °C)
- the mode of operation (Flame = Heating mode, Snowflake = Cooling mode)
- Binary Input status (BIN) when a (user-supplied) binary input (switch) is connected and closed to enable the temperature setback feature.

During setup and adjustment, the LCD displays the parameter code screens and the parameter value screens. See the [A421 Control Parameter Setup Menus](#) on page 9 for more information.

Three-Button Touchpad

The touchpad has three buttons for setup and adjustment of the A421 control (Figure 5). See [Menu Navigation Guidelines](#) on page 9 for more information on using the three-button touchpad.

Relay Status LED

The green LED on the front panel illuminates when the SPDT output relay is energized and the LC and LNO contacts are closed. See Figure 5.

Parameter Codes and Modes of Operation

Relay Off Temperature (OFF): Select the temperature at which the output relay de-energizes, the LC to LNO relay contacts open (cutout), and the green LED goes off. The range of usable temperature values is -40 to 212 °F (-40 to 100 °C) in 1° increments.

Relay On Temperature (On): Select the temperature at which the output relay energizes, the LC to LNO relay contacts close (cut in), and the green LED lights. The range of usable temperature values is -40 to 212 °F (-40 to 100 °C) in 1° increments.

Heating or Cooling Mode of Operation: When you select your desired **On** and **OFF** values, the control automatically determines the mode of operation and displays the proper mode icon on the Main screen.

Note: The A421 Series controls do **not** have jumpers for setting up the heating or cooling mode.

The heating or cooling mode is determined by the **On** and **OFF** value relationship as follows:

- **OFF > On** = Heating mode = Flame icon
- **OFF < On** = Cooling mode = Snowflake icon

IMPORTANT: During normal operation, just the **On** value or just the **OFF** value on the A421 control changes the differential between **On** and **OFF**, and can potentially change the mode of operation from heating to cooling or cooling to heating. To maintain a constant differential between **On** and **OFF**, you must adjust both the **On** value and **OFF** value by an equal number of degrees; or set up the control in the Restricted Adjustment Mode. See [Restricting User Adjustment](#).

Anti-Short Cycle Delay (ASd): Select the minimum time that the output relay remains off (de-energized) before the next on-cycle can start. The ASd interval overrides any load demand (On) and does not allow the output relay to go on until the selected ASd interval has elapsed. See Figure 6.

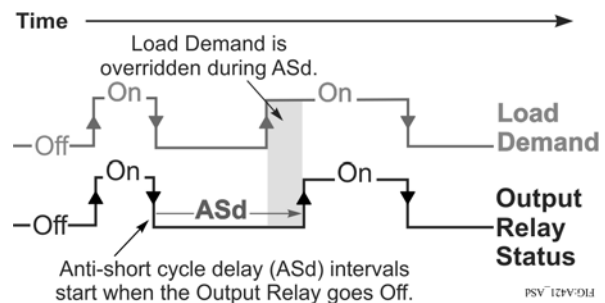

Figure 6: Anti-Short Cycle Delay

Anti-short cycle delay is typically used for refrigeration applications to allow the system pressure to equalize before restarting the compressor.

Note: When the ASd value is greater than 0, the delay interval is initiated every time that the A421 control is powered on and every time that an off-cycle begins. When the ASd interval is activated, the temperature sensed at the A99 sensor and the parameter code **ASd** flash (alternately) on the LCD. The ASd interval can be set from 0 to 12 minutes, in 1-minute increments.

Sensor Failure Mode (SF): Select how the control's output relay operates (energized or de-energized) in the event of a sensor or sensor wiring failure. When the control detects a sensor circuit failure, the output relay operates in the selected sensor failure mode. The LCD flashes **SF** and **OP** if the sensor circuit is open or **SF** and **SH** if the sensor circuit is shorted.

Temperature Units (Un): Select the desired temperature scale for your application. Select either the Fahrenheit (°F) or Celsius (°C) temperature scale.

Note: After changing the temperature units value (Un), confirm that the temperature values for the other parameter codes are still correct for your application.

Low Temperature Stop (LtS): Select the lowest temperature value that the On/OFF control band can be adjusted to when control adjustment is restricted.

High Temperature Stop (HtS): Select the highest temperature value that the On/OFF control band can be adjusted to when control adjustment is restricted.

Restricted Adjustment Mode: The HtS and LtS values define the restricted adjustment temperature range and are enforced only when the A421 control is set to the restricted adjustment mode (Figure 9). See *Restricting User Adjustment*.

Note: We recommend leaving HtS and LtS at their default values, unless you intend to use the restricted adjustment mode.

Note: If you use the Temperature Setback feature in the Restricted Adjustment Mode, the **effective** On and OFF setback values (On + tBs and OFF + tBs) can be greater than the selected HtS value or less than the selected LtS value.

Temperature Setback (tSb) Select a temperature value for *setting back* the On and OFF temperature values. When a (user-supplied) switch between the BIN and COM terminals closes:

- the Main screen displays BIN in the upper-right corner of the LCD.
- the temperature setback feature is enabled and the control uses the **effective** On and OFF setback values (On + tSb and OFF + tSb) to control the relay.

Note: The control displays only the original On and OFF values in both the normal and setback modes. The **effective** setback On and OFF values (On + tSb and OFF + tSb) are never displayed on the control LCD.

The temperature setback adjustment range is from -50 to 50 F° (-30 to 30 C°). Typically, heating applications require a negative temperature setback (tSb) value, and cooling applications require a positive value.

Sensor Offset Adjustment (So): Sensor offset allows you to compensate for any difference between the displayed temperature value and the temperature sensed at the A99 sensor. Select a temperature value to offset the temperature displayed on the LCD from the temperature sensed at the sensor. The sensor offset adjustment range is from -5 to 5 F° (-3 to 3 C°) in 1° increments.

Backlight Brightness Level (bLL): The backlight brightness level feature allows you to adjust the LCD backlight intensity. At level 0 the backlight is off. Level 10 is the brightest backlight setting and the system default. The selected backlight brightness level is applied to the LCD during normal operation. When you enter the programming menus to set up the control or press any key, the LCD automatically goes to the brightest level. If no key is pressed for 30 seconds, the main screen is displayed and the backlight setting reverts to the selected brightness level.

Table 4: Standard Parameter Setup Codes, Descriptions, Range of Values, and Default Values (Part 1 of 2)

Parameter Code	Parameter Description (Menu)	Range of Usable Values	Factory Default Values Shown
Un	Temperature Units (Advanced only)	°F or °C	°F
OFF	Relay Off Temperature (Basic, Advanced, and Restricted)	-40 to 212 °F (-40 to 100 °C)	25 °F

Table 4: Standard Parameter Setup Codes, Descriptions, Range of Values, and Default Values (Part 2 of 2)

Parameter Code	Parameter Description (Menu)	Range of Usable Values	Factory Default Values Shown
On	Relay On Temperature (Basic and Advanced)	-40 to 212 °F (-40 to 100 °C)	30 °F
ASd	Anti-Short Cycle Delay (Basic and Advanced)	0 to 12 (minutes)	0 (minute)
tSb	Temperature Setback (Advanced only)	-50 to 50 °F (-30 to 30 °C)	0 (°F)
So	Sensor Offset Adjustment (Advanced only)	-5 to 5 °F (-3 to 3 °C)	0 (°F)
HtS	High Temperature Stop (Advanced only)	-40 to 212 °F (-40 to 100 °C)	212 °F
LtS	Low Temperature Stop (Advanced only)	-40 to 212 °F (-40 to 100 °C)	-40 °F
SF	Sensor Failure Action (Basic and Advanced)	0 = output relay de-energized 1 = output relay energized	1 (output relay energized)
bLL	LCD Backlight Brightness Level Adjustment (Advanced only)	0 to 10; 0 = backlight off, 10 = brightest backlight setting	10 (brightest backlight)

A421 Control Parameter Setup Menus

The A421 temperature controls provide a Basic and an Advanced setup menu that allow you to scroll through the parameter setup codes, view and edit parameter values, and set up your control for your application requirement. The control also has a Restricted (adjustment) menu. See *Restricting User Adjustment* for more information.

Note: The A421 control retains a copy of the saved parameter values in memory. When you change and save a new value, the new value immediately overwrites the previous value and is saved to memory. In the event of a power failure, brown out, or when you disconnect power from the control, all of the current parameter values in memory are retained. Reconnecting power to the control restores all of the saved values.

Menu Navigation Guidelines

The A421 control buttons and display operate the same in Basic and Advanced menu options. While in any parameter **code** screen, the following behavior is observed:

- The parameter code flashes on and off.
- Press ▲ or ▼ to navigate through all of the parameter code screens.

- To exit either menu and return to the Main screen, press ▲ and ▼ simultaneously.

While in any parameter **value** screen, the following behavior is observed:

- The parameter value flashes on and off.
- Press ▲ or ▼ to scroll through all of the available parameter values for the associated parameter code.
- With the preferred parameter value displayed, press **MENU** to save the value and go to the next parameter code screen.

Note: If you do not press **MENU** to save a new value, the control reverts to the last saved value.

After 30 seconds of inactivity, while in any screen, the control reverts to the Main screen.

Basic Menu

The Basic menu allows you to quickly edit the **On** and **OFF** temperature values, as well as the Sensor Failure Mode (**SF**) and Anti-Short Cycle Delay (**ASd**) value.

See *Parameter Codes and Modes of Operation* and Table 4 for more information regarding parameter codes, usable parameter values, and default values.

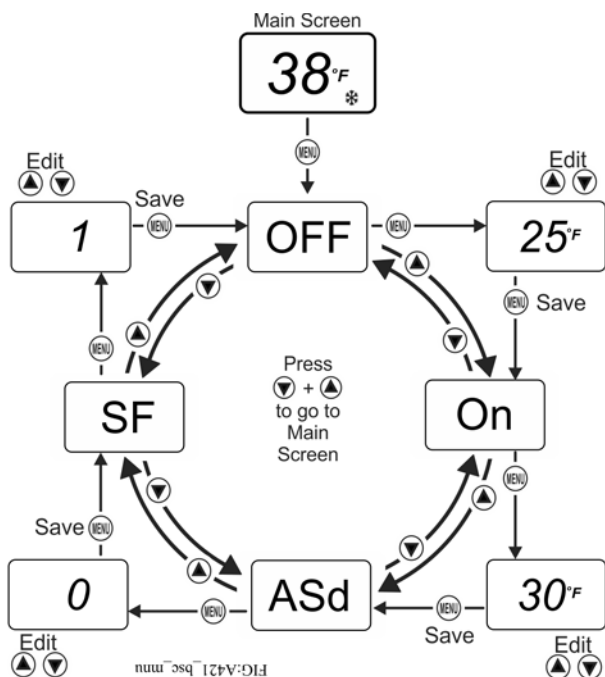

Figure 7: Navigating the Basic Menu (Factory Default Values Shown)

Viewing and Changing Values in the Basic Menu

To access the Basic menu and view and change the Basic parameter values, follow these steps:

1. With the Main screen displayed, press **MENU**. The LCD displays **OFF**, which is the first parameter code screen displayed in the Basic menu.
 -
 -
2. Press **▲** or **▼** to scroll through all of the Basic parameter codes and display the preferred code.
 -
 -
3. With the preferred parameter code displayed, press **MENU** to display the current parameter value for the code.
 -
 -
4. With the current parameter value displayed, press **▲** or **▼** to scroll through all of the parameter's usable values and display the preferred value.
 -
 -
5. With the preferred parameter value displayed, press **MENU** to save the displayed value and go to the next parameter code.
 -
 -

To exit the Basic menu and go directly into the Advanced menu, simultaneously press **▲** and **▼**, and hold them for 5 seconds.

Advanced Menu

The Advanced menu allows you to change the parameter values in the Basic menu and the parameter values for the Advanced parameter codes; including Temperature Units (**Un**), Temperature Setback (**tSb**), Sensor Offset (**So**), High Temperature Setpoint Stop (**HtS**), Low Temperature Setpoint Stop (**LtS**), and Backlight Level (**bLL**).

See *Parameter Codes and Modes of Operation* and Table 4 for more information regarding parameter codes, usable parameter values, and default values.

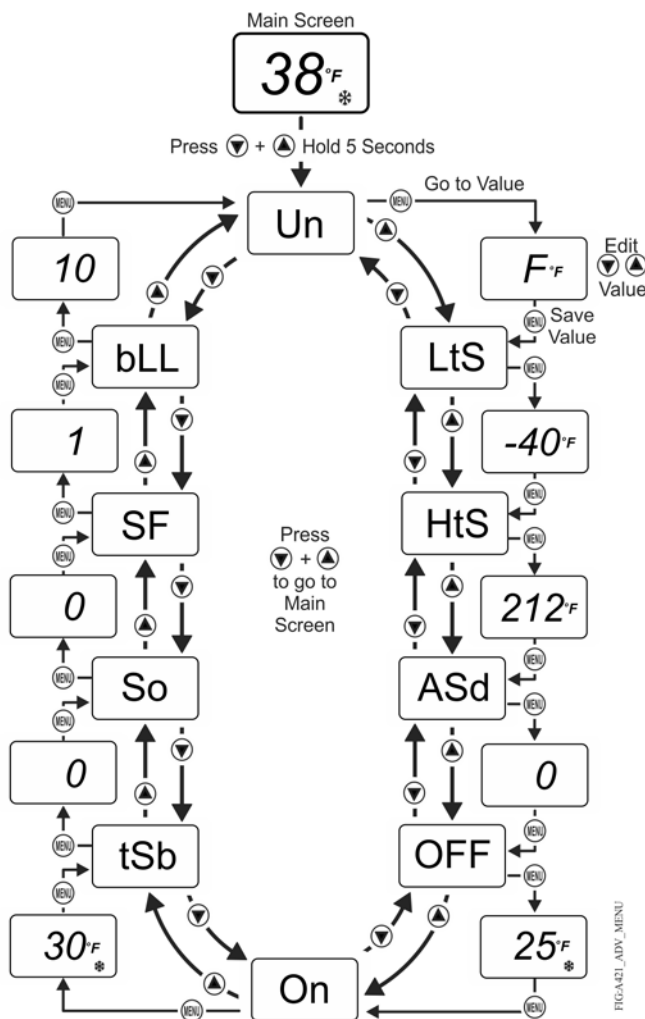











Figure 8: Navigating the Advanced Menu (Factory Default Values Shown)

Viewing and Changing Values in the Advanced Menu

To access the Advanced menu and view and change the parameter values, follow these steps:

1. With the Main screen displayed, press and hold ▲ and ▼ simultaneously for 5 seconds. The LCD displays **Un**, which is the first parameter code screen displayed in the Advanced menu.
 

2. Press ▲ or ▼ to scroll through all of the Advanced parameter codes and display the preferred code.
 

3. With the preferred parameter code displayed, press **MENU** to display the current parameter value for the code.
 

4. With the current parameter value displayed, press ▲ or ▼ to scroll through all of the parameter code's usable values and display the preferred value.
 

5. With the preferred parameter value displayed, press **MENU** to save the displayed value and go to the next parameter code.
 

Restricting User Adjustment

You can restrict user adjustment of the A421 control to either just OFF value (control band) only and limit the range of this value (Figure 9).

You set the A421 control into the restricted adjustment mode by positioning the jumper located on the circuit board next to the TB3 terminal block. See [Setting the Control to Restricted Adjustment Mode](#).

Note: Setting the A421 control up in the Restricted Mode prevents casual users from over-adjusting the control in your application, or from inadvertently changing the mode of operation from cooling to heating or heating to cooling (by over-adjusting the **On** value or **OFF** value).

When the A421 control is set up in the restricted adjustment mode, the following behavior is enforced:

- The restricted temperature adjustment range is defined by the selected High Temperature Stop (**HtS**) and Low Temperature Stop (**LtS**) values.
- The control band (differential) is defined by the **On** and **OFF** values, and the control band between On and OFF remains fixed (not adjustable).
- Only the **OFF** value can be adjusted, the control band remains fixed, and the On value automatically shifts equal to the OFF value adjustment.
- The **OFF** value can only be adjusted to values that maintain the entire control band within the restricted temperature adjustment range defined by HtS and LtS. See Figure 9.
- The basic and advanced menus are not available. Only the restricted adjustment mode menu is available and only the **OFF** value can be adjusted. See Figure 11.

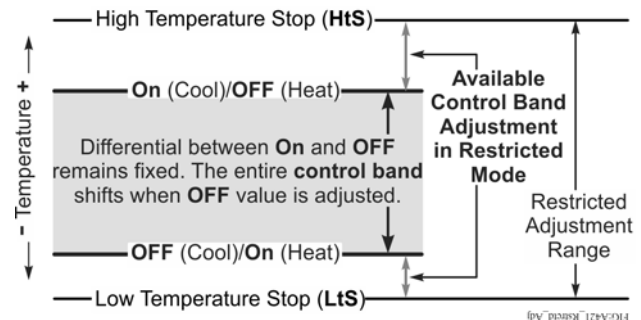

Figure 9: Adjustment Behavior in Restricted Adjustment Mode

Setting the Control to Restricted Adjustment Mode

To set up the restricted adjustment feature:

1. Ensure that the A421 is not in the restricted mode (the jumper is positioned on both pins). See Figure 10.
2. Select the **OFF** and **On** values that define the application's required control band (Figure 9).
3. Change the **HtS** and **LtS** temperature values to define the restricted adjustment range (Figure 9).

4. Disconnect power to the control and reposition the jumper to one pin (Figure 10). Reconnect power.

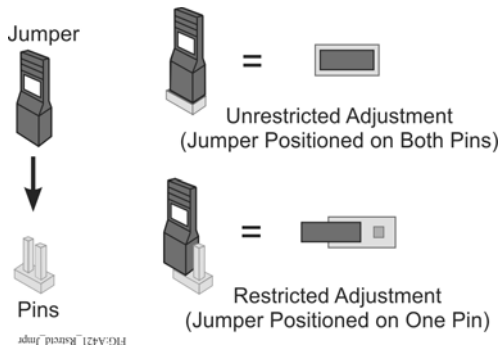

Figure 10: Repositioning the Jumper to Restrict Control Adjustment

Control adjustment is now restricted to changing only the **OFF** value, which shifts the On/OFF control band within the restricted adjustment range defined by HtS and LtS (Figure 9).

Note: To completely restrict (and lockout) all user adjustment on the control, set HtS = On or OFF and LtS = OFF or On. Then the (On to OFF) control band is equal to the restricted adjustment range (LtS to HtS) and the OFF value cannot be adjusted in the restricted mode.

Adjusting the Control In Restricted Mode

To adjust the **OFF** value (and shift the On/OFF control band) within the restricted adjustment range, when the control is in the restricted adjustment mode:

1. In the Main Screen, press **MENU** to go to the restricted adjustment mode menu and display the **OFF** parameter code screen (Figure 11).

Table 5: Fault Codes Defined

Fault Code	Definition	System Status	Solution
SF flashing alternately with OP	Open temperature sensor or sensor wiring	Output functions according to the selected sensor failure mode (SF)	See <i>Troubleshooting Procedure</i> . Cycle power to reset the control.
SF flashing alternately with SH	Shorted temperature sensor or sensor wiring	Output functions according to the selected sensor failure mode (SF)	See <i>Troubleshooting Procedure</i> . Cycle power to reset the control.
EE	Program failure	Output is off	Reset control by pressing the MENU button. If problems persist, replace the control.

Troubleshooting Procedure

1. Check for proper voltage to the A421 control.
 - a. Remove the cover by loosening the two captive cover screws.
 - b. Use an AC voltmeter to check the voltage between the COM and 120V or 240V terminals on line-voltage models and the two 24V terminals on low-voltage models. See Figure 4.
 - c. The voltage must be between:
 - 20 and 30 VAC for 24 VAC applications

2. Press **MENU** again to go to the **OFF** value screen.
3. In the **OFF** value screen, press **▲** or **▼** to change the **OFF** value (only within the restricted adjustment range).
4. Press **MENU** to save the selected **OFF** value and return to the **OFF** code screen.
5. Press **▲** and **▼** simultaneously to return to the Main screen.

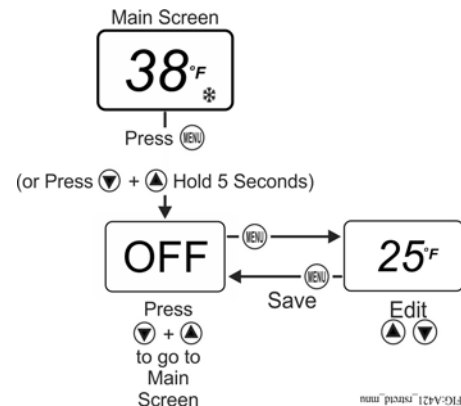

Figure 11: Adjusting Temperature in the Restricted Menu (Factory Default Values Shown)

Troubleshooting

Fault Codes

A421 Series controls display fault codes on the LCD as described in Table 5.

- 102 and 132 VAC for 120 VAC applications
 - 177 and 264 VAC for 208/240 VAC applications
- d. If the voltage reading is not within the required range, check the power source and input power wires for problems.
2. Check for proper sensor operation.
 - a. Disconnect all power sources to control.
 - b. Using an accurate thermometer, take a temperature reading at the sensor location.
 - c. Disconnect the sensor from the control.
 - d. Using an ohmmeter, measure the resistance across the two sensor leads while the sensor is at the temperature taken in Step 2b.
 - e. Consult Figure 12 to verify that the measured temperature and resistance conform to established temperature and resistance values.
 - f. If the measured values conform to the values in Figure 12, proceed to Step 3.
 - g. If the sensor's measured resistance value is substantially different from the expected value for that temperature, check the sensor wiring. If sensor wiring is correct, replace the sensor.

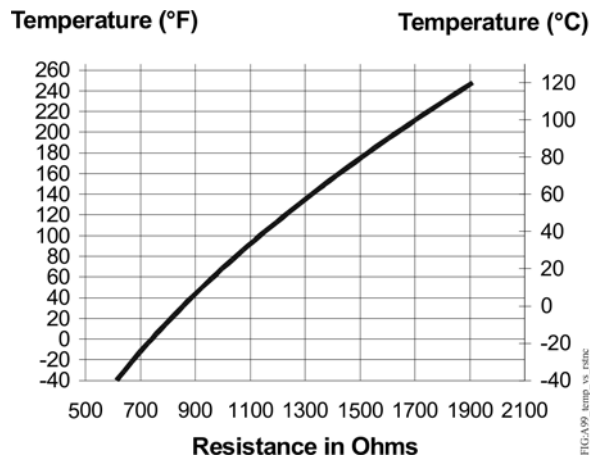

Figure 12: Temperature versus Sensor Resistance

3. Check the A421 for proper operation.

Note: Perform Troubleshooting Steps 1 and 2 before performing this step.

- a. Disconnect the load from the output relay terminals.
- b. Ensure that the Parameter Adjustments jumper is installed, so that access to adjust parameters is unrestricted.
- c. Reconnect the sensor leads and supply power to the control.
- d. Replace the cover.
- e. Check the control settings for proper values.
- f. Press **MENU** until **On** appears. Press **MENU** again to display the **On** value.
- g. Press **▲** and **▼** to change the **On** temperature above and below the sensor temperature until the relay energizes and de-energizes.

Note: If the anti-short cycle delay is set to a value other than 0 minutes, when the control is powered On, the relay does not energize until the time delay has elapsed.

- h. If the output relay does not perform as expected, replace the A421 control.
- i. If proper operation of the A421 control is verified, reconnect the load and consult the equipment manufacturer's instructions for troubleshooting the controlled equipment.

Repair Information

Do not attempt to repair or recalibrate the A421 temperature control. In case of a defective or improperly functioning control, contact your nearest Authorized Johnson Controls/PENN Distributor or Sales Representative.

When contacting your Johnson Controls/PENN Distributor, have the model number of the control available. This number can be found on the label inside the cover of the control.

Ordering Information

See Table 6 to order a standard A421 Series Electronic Temperature Control. See Table 7 and Table 8 to order A99 sensors, mounting hardware, and other accessories used to install A421 controls. Contact your nearest Johnson Controls/PENN distributor or sales representative to order these products.

Table 6: A421 Series Standard Electronic Temperature Controls Selection Chart

Product Type	Description
A421ABC-02C	Line-Voltage Type 1 Electronic Temperature Control: Type 1 (NEMA), IP20 standard enclosure for DIN rail and surface-mount applications. Rated for 120/240 VAC. Includes an A99BB-200C temperature sensor with 6.6 ft (2.0 m) cable.
A421ABC-03C	Line-Voltage Type 1 Electronic Temperature Control: Type 1 (NEMA), IP20 standard enclosure for DIN rail and surface-mount applications. Rated for 120/240 VAC. Includes an A99BB-300C temperature sensor with 9.75 ft (3.0 m) cable.
A421ABC-04C	Line-Voltage Type 1 Electronic Temperature Control: Type 1 (NEMA), IP20 standard enclosure for DIN rail and surface-mount applications. Rated for 120/240 VAC. Includes an A99BB-400C temperature sensor with 13.1 ft (4.0 m) cable.
A421ABC-06C	Line-Voltage Type 1 Electronic Temperature Control: Type 1 (NEMA), IP20 standard enclosure for DIN rail and surface-mount applications. Rated for 120/240 VAC. Includes an A99BB-600C temperature sensor with 19.5 ft (6.0 m) cable.
A421AEC-01C	Line-Voltage Type 4X Electronic Temperature Control: Type 4X (NEMA), IP66 watertight enclosure for surface-mount applications. Rated for 120/240 VAC. Includes an A99BB-25C temperature sensor with 9-7/8 in. (0.25 m) cable.
A421AEC-02C	Line-Voltage Type 4X Electronic Temperature Control: Type 4X (NEMA), IP66 watertight enclosure for surface-mount applications. Rated for 120/240 VAC. Includes an A99BB-200C temperature sensor with 6.6 ft (2.0 m) cable.
A421GBF-02C	Low-Voltage Type 1 Electronic Temperature Control: Type 1 (NEMA), IP20 standard enclosure for DIN rail and surface-mount applications. Rated for 24 VAC Class 2, Safety Extra Low Voltage. Includes an A99BB-200C temperature sensor with 6.6 ft (2.0 m) cable.
A421GEF-01C	Low-Voltage Type 4X Electronic Temperature Control: Type 4X (NEMA), IP66 watertight enclosure for surface-mount applications. Rated for 24 VAC Class 2, Safety Extra Low Voltage. Includes an A99BB-25C temperature sensor with 9-7/8 in. (0.25 m) cable.
A421GEF-02C	Low-Voltage Type 4X Electronic Temperature Control: Type 4X (NEMA), IP66 watertight enclosure for surface-mount applications. Rated for 24 VAC Class 2, Safety Extra Low Voltage. Includes an A99BB-200C temperature sensor with 6.6 ft (2.0 m) cable.

Table 7: A99 Temperature Sensors Selection Chart¹ (Part 1 of 2)

Product Code	Description
A99BA-200C	PTC Temperature Sensor: Standard probe 2 in. (5.1 cm) with 6.6 ft (2.0 m) shielded PVC cable; Ambient operating temperature range: -40 to 212°F (-40 to 100°C)
A99BB-25C	PTC Temperature Sensor: Standard probe 2 in. (5.1 cm) with 9-7/8 in. (0.25 m) PVC cable; Ambient operating temperature range: -40 to 212°F (-40 to 100°C)
A99BB-200C	PTC Temperature Sensor: Standard probe 2 in. (5.1 cm) with 6.6 ft (2.0 m) PVC cable; Ambient operating temperature range: -40 to 212°F (-40 to 100°C)
A99BB-300C	PTC Temperature Sensor: Standard probe 2 in. (5.1 cm) with 9.8 ft (3.0 m) PVC cable; Ambient operating temperature range: -40 to 212°F (-40 to 100°C)
A99BB-400C	PTC Temperature Sensor: Standard probe 2 in. (5.1 cm) with 13.1 ft (4.0 m) PVC cable; Ambient operating temperature range: -40 to 212°F (-40 to 100°C)
A99BB-600C	PTC Temperature Sensor: Standard probe 2 in. (5.1 cm) with 19.7 ft (6.0 m) PVC cable; Ambient operating temperature range: -40 to 212°F (-40 to 100°C)

Table 7: A99 Temperature Sensors Selection Chart¹ (Continued) (Part 2 of 2)

Product Code	Description
A99BC-25C ¹	PTC Temperature Sensor: Standard probe 2 in. (5.1 cm) with 9-7/8 in. (0.25 m) high-temperature silicon cable; Ambient operating temperature range: -40 to 248°F (-40 to 100°C)
A99BC-100C ¹	PTC Temperature Sensor: Standard probe 2 in. (5.1 cm) with 3.3 ft (1.0 m) high-temperature silicon cable; Ambient operating temperature range: -40 to 248°F (-40 to 120°C)
A99BC-300C ¹	PTC Temperature Sensor: Standard probe 2 in. (5.1 cm) with 9.8 ft (3.0 m) high-temperature silicon cable; Ambient operating temperature range: -40 to 248°F (-40 to 120°C)
A99BC-500C ¹	PTC Temperature Sensor: Standard probe 2 in. (5.1 cm) with 16.4 ft (5.0 m) high-temperature silicon cable; Ambient operating temperature range: -40 to 248°F (-40 to 120°C)
A99BC-1500C ¹	PTC Temperature Sensor: Standard probe 2 in. (5.1 cm) with 49.2 ft (15.0 m) high-temperature silicon cable; Ambient operating temperature range: -40 to 248°F (-40 to 120°C)
A99CB-200C	PTC Temperature Sensor: Extended probe 6 in. (15.2 cm) with 6.6 ft (2.0 m) PVC cable; Ambient operating temperature range: -40 to 212°F (-40 to 100°C)
A99CB-600C	PTC Temperature Sensor: Extended probe 6 in. (15.2 cm) with 19.7 ft (6.0 m) PVC cable; Ambient operating temperature range: -40 to 212°F (-40 to 100°C)

1. When any A99 Series Temperature Sensor is connected to a standard A421 control model, the range of displayed temperature values is -40 to 212°F or -40 to 100°C.

Table 8: Accessories for the A421 Controls

Product Code	Description
BKT287-1R	12 in. (305 mm) long DIN rail section
BKT287-2R	36 in. (914 mm) long DIN rail section
PLT344-1R	Two End Clamps for DIN rail sections
A99-CLP-1	Surface Mounting Clip for A99B and A99C Series Temperature Sensors
SHL10-603R	Sun Shield for A99B and A99C Series Temperature Sensors
BOX10A-603R	PVC Enclosure for A99B and A99C Series Temperature Sensors
WEL11A-601R	Immersion well for applying sensor in fluid applications

Technical Specifications

Table 9: A421 Series Electronic Temperature Controls

Power Consumption	1.8 VA Maximum
Supply Power	Low-Voltage Models: 24 VAC (20 to 30 VAC), 50/60 Hz, Class 2 or Safety Extra-Low Voltage Line-Voltage Models: 110/120 or 208/230/240 VAC, 50/60 Hz
Ambient Conditions	Operating: Type 1 Models: -40 to 150°F (-40 to 66°C), 0 to 95% RH Non-condensing Type 4X Models: -40 to 140°F (-40 to 60°C), 0 to 95% RH Non-condensing Shipping and Storage: All Models: -40 to 185°F (-40 to 85°C), 0 to 95% RH Non-condensing
Temperature Control Range	-40 to 212°F or -40 to 100°C
Input Signal	1,035 ohm at 77°F (25°C) for A99 PTC temperature sensors
Accuracy	Combined accuracy of A421 control and A99 sensor: ±2°F (±1°C) between 5°F and 167°F (-15°C and 75°C); diverging to ±3°F (±2°C) at -40°F (-40°C) and ±3°F (±2°C) at 212°F (100°C)
Sensor Offset Range	±5°F or ±3°C
Enclosure Material	Type 1, IP20 High-Impact Thermoplastic or Type 4X, IP66 Watertight, Corrosion-Resistant, High-Impact Thermoplastic
Compliance	North America: cULus Listed; UL 60730, File E27734, Vol. 1; FCC Compliant to CFR47, Part 15, Subpart B, Class B Industry Canada (IC) Compliant to Canadian ICES-003, Class B limits Europe: CE Mark – Johnson Controls, Inc. declares that this product is in compliance with the essential requirements and other relevant provisions of the EMC Directive; Low Voltage Directive. Australia: Regulatory Compliant Mark (RCM)

Table 10: A421 Temperature Control Output Relay Contacts Electrical Ratings

Agency and File	UL 60730 and EN 60730			
	24 VAC	120 VAC	208 VAC	240 VAC
Applied AC Voltage at 50/60 Hz				
Horsepower LC/LNO (LC/LNC)	--	1 (0.25)	1 (0.3)	1 (0.5)
Full Load Amperes LC/LNO (LC/LNC)	--	16 (5.8)	9.2 (4)	8 (4.9)
Locked Rotor Amperes LC/LNO (LC/LNC)	--	96 (34.8)	55.2 (24)	48 (29.4)
Resistive Amperes LC/LNO (LC/LNC)	15 (10)	15 (10)	10 (10)	10 (10)
Pilot Duty VA LC/LNO (LC/LNC)	125 (50)	125 (125)	125 (125)	125 (125)

Table 11: UL Conformity Declaration Information

Information	Description
Purpose of Control	Sensing Control / Operating Control
Construction of Control	Electronic Independently Mounted Control
Number of Cycles	30,000 Cycles
Method of Mounting Control	Mounting Screws or DIN Rail
Type 1 or Type 2 Action	Type 1.B (Micro-disconnection)
External Pollution Situation	All Models: A421 [] B: Pollution Degree 3 All Models: A421 [] E: Pollution Degree 4
Internal Pollution Situation	Pollution Degree 2
Heat and Fire Resistance Category	D
Rated Impulse Voltage	4000 V
Ball Pressure Temperature	128 C
Cover Screw Torque Requirements Instruction	All Models: A421 [] E: To Maintain Type 4X / IP66 Rating, Tighten Enclosure Screws to: 10 - 12 in·lb

Table 12: A99B Series Positive Temperature Coefficient Sensors

Sensing Range¹	Type A99BA and A99BB: -40 to 212°F (-40 to 100°C) Type A99BC: -40 to 248°F (-40 to 120°C)
Reference Resistance	1,035 ohms at 77°F (25°C) and 855 ohms at 32°F (0°C)
Accuracy	0.9°F (0.5°C) between 5°F and 167°F (-15°C and 57°C). Refer to the <i>A99B Series Temperature Sensors Product/Technical Bulletin (LIT-125186)</i> for accuracy rating outside of this temperature range.
Sensor Construction	Probe: Stainless Steel
Sensor Cable Sheath	Type A99BA: Shielded PVC Cable Type A99BB: PVC Cable Type A99BC: High Temperature Silicon Cable
Wire Gauge	22 AWG
Ambient Operating Conditions	Type A99BA and A99BB: -40 to 212°F (-40 to 100°C); 0 to 100% RH, Condensing Type A99BC: -40 to 248°F (-40 to 120°C); 0 to 100% RH, Condensing
Ambient Storage Conditions	Type A99BA and A99BB: -40 to 221°F (-40 to 105°C); 0 to 100% RH, Condensing Type A99BC: -40 to 266°F (-40 to 130°C); 0 to 100% RH, Condensing
Shipping Weight	1.4 oz (41 g) for 6 1/2 ft (2 m) sensor
Accessories	See Table 8

1. When any A99 Series Temperature Sensor is connected to a standard A421 control model, the range of displayed temperature values is -40 to 212°F or -40 to 100°C.

The performance specifications are nominal and conform to acceptable industry standards. For application at conditions beyond these specifications Johnson Controls, Inc. shall not be liable for damages resulting from misapplication or misuse of its products.

United States Emissions Compliance

This equipment has been tested and found to comply with the limits for a Class B digital device, pursuant to Part 15 of the FCC Rules. These limits are designed to provide reasonable protection against harmful interference in a residential installation. This equipment generates, uses and can radiate radio frequency energy and, if not installed and used in accordance with the instructions, may cause harmful interference to radio communications. However, there is no guarantee that interference will not occur in a particular installation. If this equipment does cause harmful interference to radio or television reception, which can be determined by turning the equipment off and on, the user is encouraged to try to correct the interference by one or more of the following measures:

- Reorient or relocate the receiving antenna.
- Increase the separation between the equipment and receiver.
- Connect the equipment into an outlet on a circuit different from that to which the receiver is connected.
- Consult the dealer or an experienced radio/TV technician for help.

Canadian Emissions Compliance

This Class (B) digital apparatus meets all the requirements of the Canadian Interference-Causing Equipment Regulations. Cet appareil numérique de la Classe (B) respecte toutes les exigences du Règlement sur le matériel brouilleur du Canada.



Building Efficiency

507 E. Michigan Street, Milwaukee, WI 53202

Johnson Controls® and PENN® are registered trademarks of Johnson Controls, Inc. in the United States of America and/or other countries. All other trademarks used herein are the property of their respective owners. © Copyright 2015 by Johnson Controls, Inc. All rights reserved.