

NOTES:

1. COIL WOUND USING COPPER MAGNET WIRE WITH CLASS 155 SINGLE BUILD POLYURETHANE INSULATION.
2. FINISH WIRE ON COIL IS SECURED WITH BLUE DOT OF PAINT.
3. BOBBIN IS FULLY ANNEALED HYMU80 WITH PARYLENE COATING.
4. WITH A POSITIVE DC VOLTAGE APPLIED TO THE "FINISH" WIRE, THE MAGNETIC FIELD WILL ATTRACT A COMPASS NEEDLE AS SHOWN.
5. START AND FINISH WIRE TO LIE TIGHT AGAINST COIL.
6. COIL TO BE DIPPED AT LEAST 4 TIMES WITH 13-863 (CONATHANE CE-1164) TO PROVIDE A UNIFORM LAYER OF PROTECTION ON COIL WIRES.
7. SENSITIVITY MEASUREMENT IN dB re 1.0 VOLT WITH A MAGNETIC FIELD STRENGTH OF 1 A/M APPLIED TO THE COIL, LONG AXIS OF THE TELECOIL IS PARALLEL TO THE TEST MAGNETIC FIELD.
8. SOLDER SHALL NOT CONTAIN LEAD. MUST BE ROHS COMPLIANT.

ELECTRICAL CHARACTERISTICS

| # OF TURNS | WIRE SIZE           | INDUCTANCE @ 1KHZ (mH)±15% | DCR@25°C (ohms)±10% | SENSITIVE @ 1KHZ (dB) ±2dB | w/10k Ω LOAD |
|------------|---------------------|----------------------------|---------------------|----------------------------|--------------|
| 9300       | 56H HIGH RESISTANCE | 510                        | 5400                | -57.00                     | -61.2        |

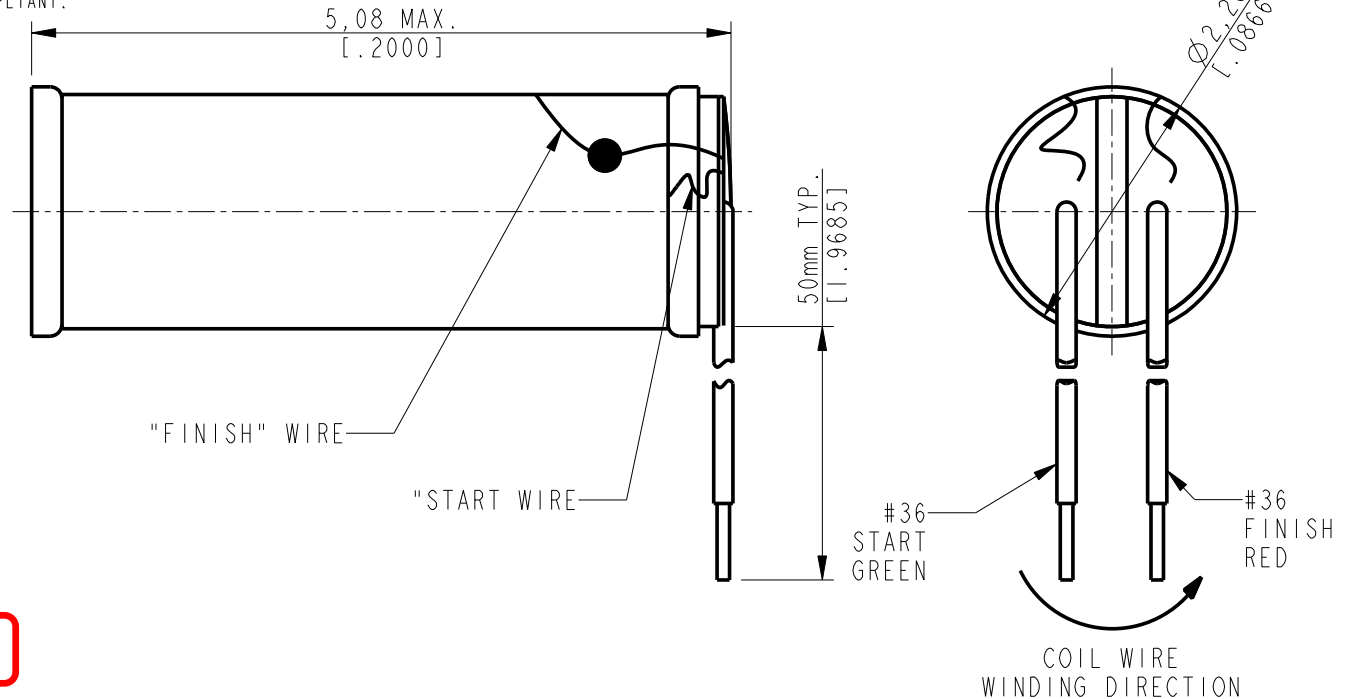
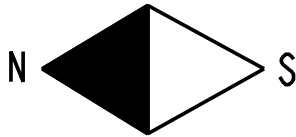

**RED CONTROLLED**

|   |           |          |      |                                       |      |   |
|---|-----------|----------|------|---------------------------------------|------|---|
|   |           |          |      | SCALE: 20:1                           |      | MATERIAL: - - -                                     |
|   |           |          |      | FUNDAMENTAL TOLERANCE: ± 0.03 [0.001] |      | HEAT TREATMENT:                                     |
|   |           |          |      | ANGLE TOLERANCE: ± 1°                 |      | FINISH:   |
|   |           |          |      | MISMATCH TOLERANCE: ± 0.03 [0.001]    |      | TITLE:  |
| C   | C10110669 | 1-7-10   | SDZ  | DATE                                  | NAME | <b>FINISHED 04 STYLE COIL W/RADIAL TERMINAL PAD</b> |
| B   | C10104995 | 11/03/06 | BCS  | DESIGNED 01/10/06                     | BCS  |   |
| A   | C10103768 | 01/12/06 | BCS  | CHECKED 01/10/06                      | BCS  |   |
| REV.  | CHANGE #  | DATE     | NAME | RELEASED 01/10/06                     | TDS  |   |
| PROPRIETARY NOTE: THIS DOCUMENT CONTAINS INFORMATION WHICH IS THE PROPRIETARY PROPERTY OF KNOWLES ELECTRONICS, LLC. OR ITS AFFILIATED ENTITIES. IT IS ISSUED IN STRICT CONFIDENCE AND SHALL NOT BE REPRODUCED, COPIED, USED, OR DISCLOSED TO ANY THIRD PARTY PARTIALLY OR WHOLLY IN ANY MANNER WITHOUT PRIOR WRITTEN PERMISSION OF, AND MUST BE RETURNED UPON REQUEST BY, KNOWLES ELECTRONICS, LLC. |           |          |      |                                       |      | RELEASED LEVEL: Active                              |
|   |           |          |      |                                       |      | DRAWING NUMBER: 5100-253630                         |
|   |           |          |      |                                       |      | SHEETS: 1 of 1                                      |