

APPROVAL SHEET



WLFW2012
Wire Wound Ferrite Chip Inductors

*Contents in this sheet are subject to change without prior notice.

FEATURES

1. General Purpose Inductor for any electronic device.
2. Wire Wound structure with Lower DCR High Q
3. Standard Chip size

APPLICATIONS

1. General Purposes in Analog signal process
2. LC Filter, EMI rejection and Noise rejection notch.

SHAPE and DIMENSION

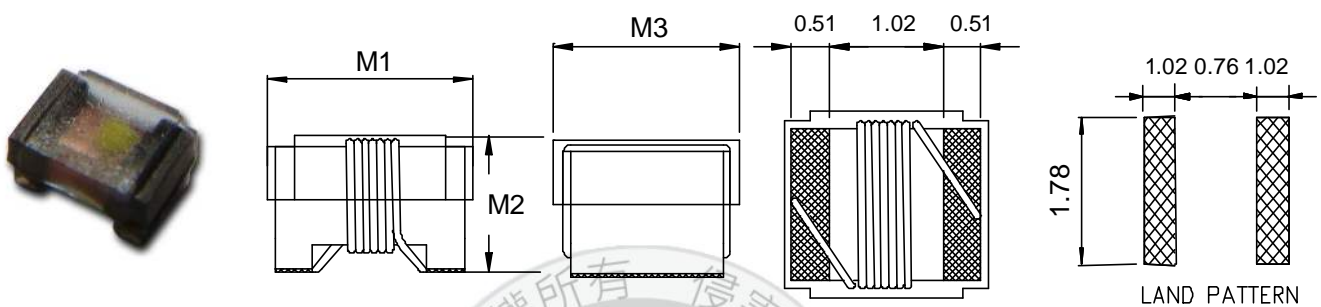

Unit: mm

Series	M1	M2	M3
WLFW2012	2.29(MAX)	1.60(MAX)	1.91(MAX)

MARKING

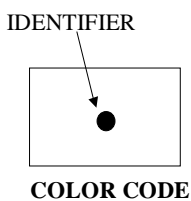

Example : WLFW2012Z0□78NPB

MARKING : BLACK

MARK COLOR CODE IN COMPOSITE SPECIFICATION

ORDERING INFORMATION

WL	FW	2012	Z0	J	78N	P	B
Product Code	Series	Dimensions	Series extension	Tolerance	Value	Packing Code	
WL: Inductor	Wire Wound Ferrite Chip inductor.	2.0 * 1.2 mm 2012 :EIA 0805	STD	J: ± 5% K: ± 10%	78N =78nH =0.078uH R11=0.11uH 1R0=1.0uH 100 = 10uH	P= 7" Plastic Tape	B:STD

Electrical Characteristics

● WLFW2012 series

Walsin Part Number	L (uH)	Tolerance	Q (Min)	Measuring Frequency (MHz)	SRF (MHz) Min	RDC Max (Ω)	Irms (mA)	COLOR CODE
WLFW2012Z0□78NPB	0.078	J、K	19	7.9	1440	0.042	2000	BLACK
WLFW2012Z0□R11PB	0.11	J、K	19	7.9	1400	0.05	2000	BROWN
WLFW2012Z0□R18PB	0.18	J、K	15	7.9	1000	0.15	500	GRAY
WLFW2012Z0□R22PB	0.22	J、K	15	7.9	1000	0.15	500	VIOLET
WLFW2012Z0□R33PB	0.33	J、K	15	7.9	862	0.25	300	WHITE
WLFW2012Z0□R39PB	0.39	J、K	15	7.9	800	0.30	500	BLACK
WLFW2012Z0□R47PB	0.47	J、K	19	7.9	500	0.31	720	RED
WLFW2012Z0□R56PB	0.56	J、K	12	7.9	800	1.20	300	RED
WLFW2012Z0□R68PB	0.68	J、K	20	7.9	400	0.46	590	ORANGE
WLFW2012Z0□R82PB	0.82	J、K	12	7.9	600	1.00	300	YELLOW
WLFW2012Z0□1R0PB	1.0	J、K	20	7.9	340	0.69	500	YELLOW
WLFW2012Z0□1R2PB	1.2	J、K	20	7.9	400	0.75	800	BLACK
WLFW2012Z0□1R5PB	1.5	J、K	20	7.9	275	0.83	490	GREEN
WLFW2012Z0□1R8PB	1.8	J、K	20	7.9	246	1.15	410	BLUE
WLFW2012Z0□2R2PB	2.2	J、K	20	7.9	106	1.28	365	VIOLET
WLFW2012Z0□2R7PB	2.7	J、K	20	7.9	105	1.48	350	GRAY
WLFW2012Z0□3R3PB	3.3	J、K	20	7.9	83	1.57	330	WHITE
WLFW2012Z0□3R9PB	3.9	J、K	20	7.9	52	1.70	300	BLACK
WLFW2012Z0□4R7PB	4.7	J、K	20	7.9	50	1.87	280	BROWN
WLFW2012Z0□5R6PB	5.6	J、K	18	7.9	40	2.00	270	BLUE
WLFW2012Z0□6R8PB	6.8	J、K	20	7.9	35	2.25	260	RED
WLFW2012Z0□8R2PB	8.2	J、K	18	2.5	27	2.55	250	ORANGE
WLFW2012Z0□100PB	10	J、K	18	2.5	21	3.45	200	YELLOW
WLFW2012Z0□120PB	12	J、K	18	2.5	37	3.80	220	BROWN
WLFW2012Z0□150PB	15	J、K	18	2.5	17	5.03	180	GREEN
WLFW2012Z0□180PB	18	J、K	18	2.5	23	4.48	180	ORANGE
WLFW2012Z0□220PB	22	J、K	18	2.5	13	6.18	150	BLUE
WLFW2012Z0□270PB	27	J、K	15	2.5	11	11.04	120	VIOLET

Tolerance : :K±10%、J±5%

※ MSL : LEVEL1

RATING TEMPERATURE

OPERATING TEMPERATURE RANGE : -40°C ~ +125°C

TEST INSTRUMENT

L、Q TEST BY HP4291B

SRF TEST BY HP 8753E

DCR TEST BY ZENTECH 502BC

RELIABILITY PERFORMANCE

Reliability Experiment For Electrical

Test Item	Test Condition	Standard Source
Humidity Test	+40°C ± 2°C, humidity of 90% ± 5% (total 96 hours).	MIL-STD-202G Method 103B Test Condition B
High Temperature Test	1. Temperature: +125°C ± 2°C 2. Test time: 48 ± 2hrs	IEC 68-2 Test Condition B
Low Temperature Test	1. Temperature: -40°C ± 2°C 2. Test time: 48 ± 2hrs	IEC 68-2 Test Condition A
Thermal Shock	+125°C ± 5°C (30 minutes) ~ -40 ± 5°C (30 minutes), temperature switch time: 5 minutes (total 50 cycles).	MIL-STD-202G Method 107G Test Condition B-2
Life Test	+70°C ± 5°C (250Hours)	MIL-STD-202G Method 108A Test Condition B

Reliability Experiment For Physical

Test Item	Test Condition	Standard Source
Vibration Test	10-55-10HZ, amplitude: 1.5mm, direction: X, Y, Z axes, each axis 2 hours (total 6 hours).	MIL-STD-202G Method 201A
Solder Heat Resistance Test	IR/convection reflow: Peak Temp 250 ± 5°C for 5Sec in air, Through 2 Cycle. Temperature Ramp: +1~4°C/sec; Above 183°C, must keep 90 s - 120 s	MIL-STD-202G Method 210F Test Condition (Reflow)
Solder Ability Test	Soak in 245 °C solder pot of 3Sec, PAD must have 95% above coverage.	J-STD-003B

TYPICAL RoHS REFLOW PROFILE

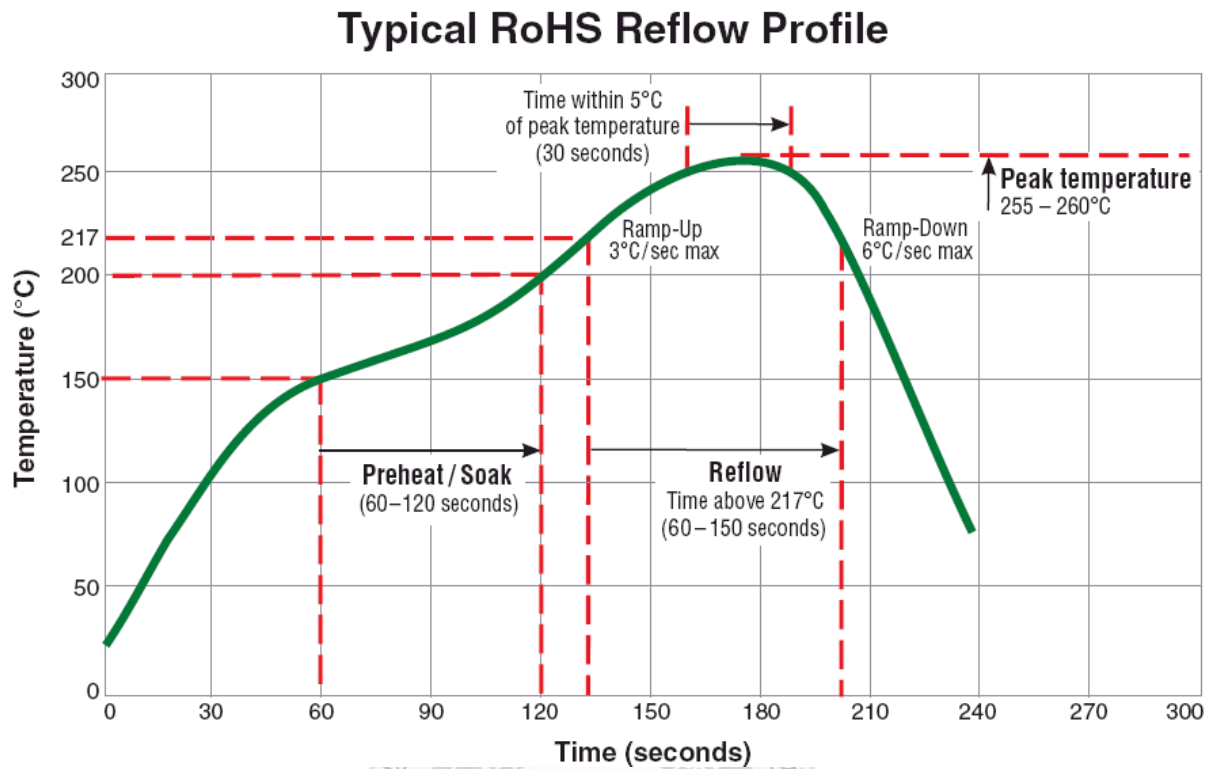

PACKAGING SPECIFICATION

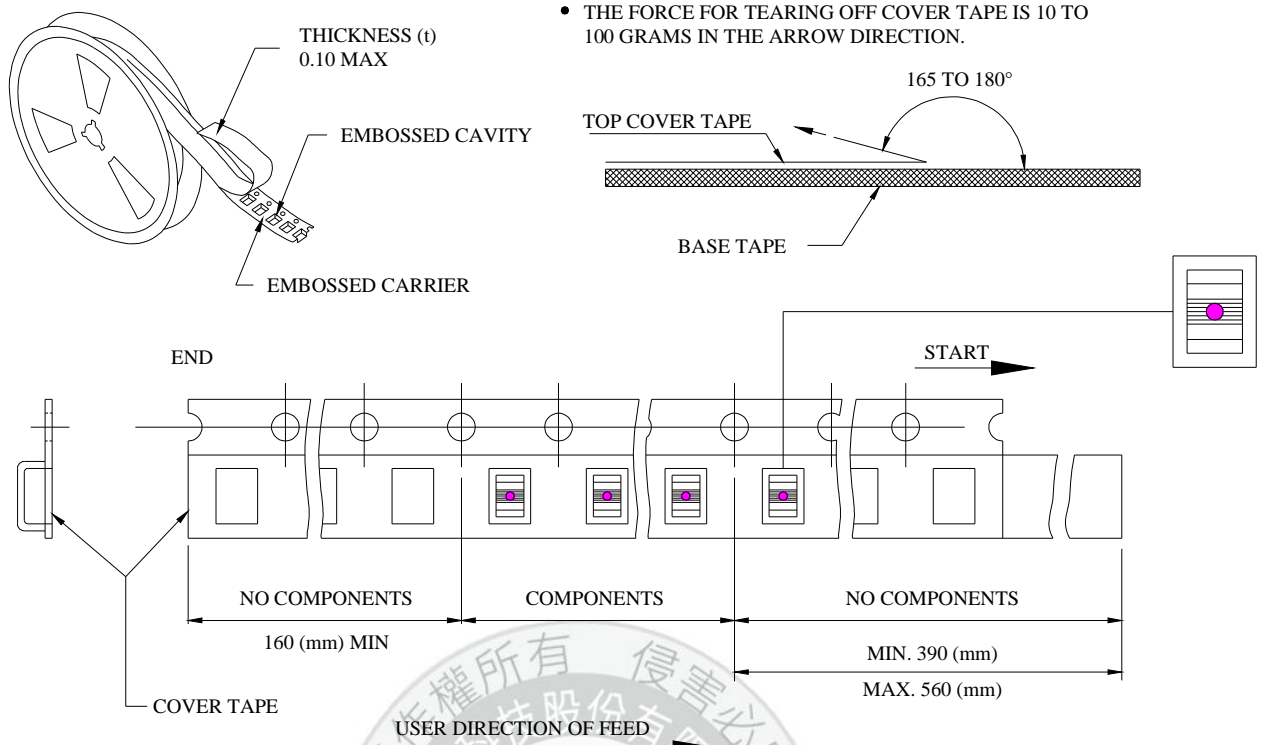

■ CARRIER TAPE REELS (mm)

MATERIAL: PLASTIC

■ DIMENSIONS OF CARRIER TAPE (mm)

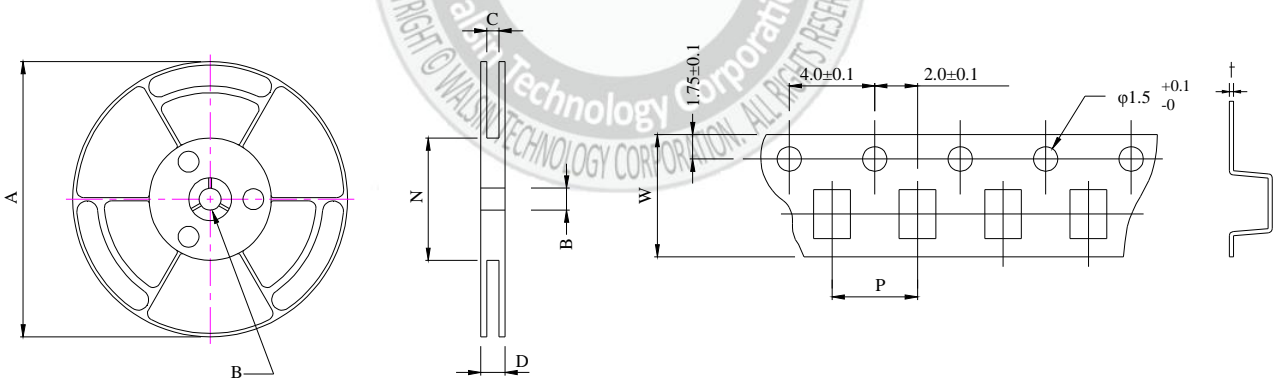

UNIT : mm

	A	B	C	D	N	P	W	t
DIM.	178	13.0	8.4	12.5	75	4.0	8.0	0.25
TOL.	±2.0	±0.8	+1.0-0	MAX	±1.5	±0.1	±0.2	±0.05

Quantity per reel : 3K pcs / reel