

DO NOT SCALE FROM THIS PRINT

DESIGNED & DIMENSIONED IN MILLIMETERS [INCHES]

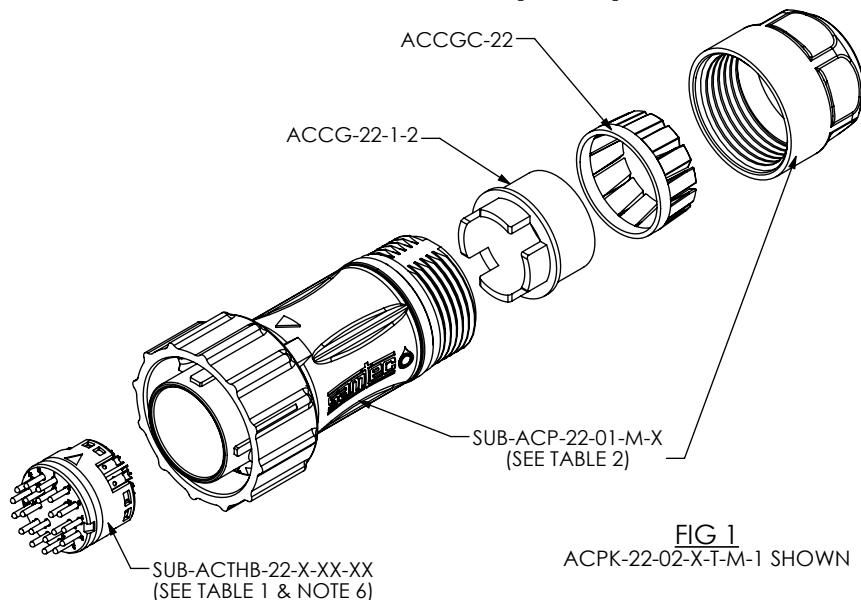

ACPK-22-XX-X-X-M-X

PLUG KIT

SIZE

KEY FEATURE

- (SEE NOTE 2, SEE SHT. 4)
- 1: ORANGE
- 2: GREEN
- 3: BLUE
- 4: YELLOW

STYLE

-M: METAL

GENDER

- T: TERMINAL
- S: SOCKET

PLATING

- G: 10µ" GOLD ON CONTACT
- H: 30µ" GOLD ON CONTACT

LEAD STYLE

- 01: 30 POS (1.0 TERM/SKT), 20 - 24 AWG
- 02: 20 POS (1.0 TERM/SKT), 20 - 24 AWG
- 03: 8 POS PWR (1.5 TERM/SKT), 14 - 18 AWG
- * -04: 6 POS (COAX PLUG/JACK), CCA-316
- 05: 20 POS COMBO (4 X 1.5 TERM/SKT, 14 - 18 AWG) (16 X 1.0 TERM/SKT, 20 - 24 AWG)
- * -06: 16 POS COMBO (4 X COAX PLUG/JACK, CCA-316) (12 X 1.0 TERM/SKT, 20 -24 AWG)

* = NOT RELEASED FOR PRODUCTION

TABLE 2

KEY FEATURE	SUB-ACP-22-XX-M-X
-1	SUB-ACP-22-01-M-1
-2	SUB-ACP-22-01-M-2
-3	SUB-ACP-22-01-M-3
-4	SUB-ACP-22-01-M-4

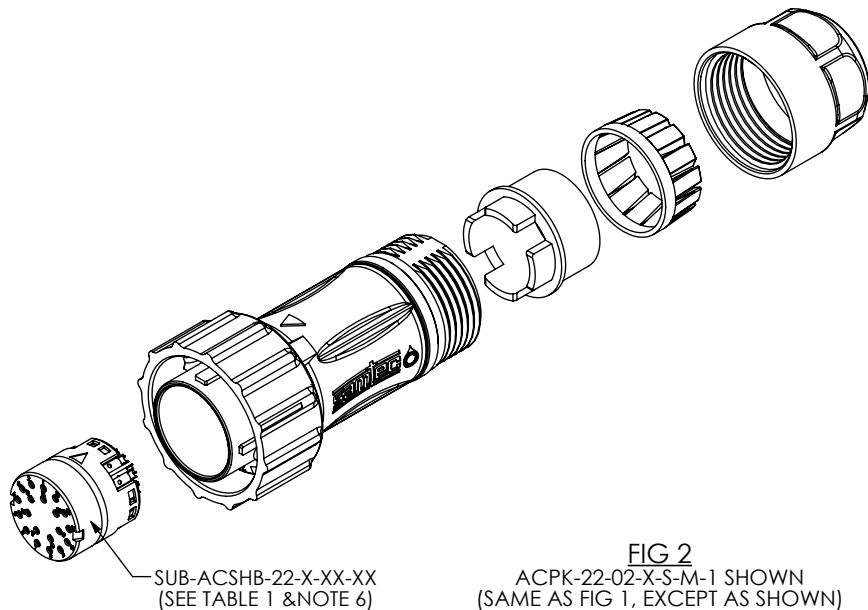

NOTES:

1. KIT COMPONENTS TO BE PACKAGED IN BAGS PER PACKAGING STANDARD CO-RF-WI-3001-M.
2. KEY FEATURE DETERMINES COLOR OF KEY RING AND DUSTCAP LANYARD IF APPLICABLE.
3. REFER TO DCA-ACP-22-M-X PRINT FOR DUST CAP.
4. TORQUE SPECIFICATION FOR CABLE NUT: 1.1Nm [10.00 IN-LB] - 1.7Nm [15.00 IN-LB].
5. CABLE DIAMETER SPECIFICATION: 8.38 [.330] - 14.22 [.560].
6. RECOMMENDED INSERTION TOOL: CAT-AC-22-M.
7. NOTE DELETED.

TABLE 1

LEAD STYLES	GENDER	SUB-ASSEMBLY/HOLDER BODY PART #		COAX PLUG/JACK PART #	
		PLATING		AC-X-C-H-ST-CA1	QTY
		-G	-H		
-01	-T	SUB-ACHTB-22-G-01	SUB-ACHTB-22-H-01	NA	
-02	-T	SUB-ACHTB-22-G-02	SUB-ACHTB-22-H-02	NA	
-03	-T	SUB-ACHTB-22-G-03	SUB-ACHTB-22-H-03	NA	
* -04	-T	ACTHB-22-6	ACTHB-22-6	AC-P-C-H-ST-CA1	6
-05	-T	SUB-ACHTB-22-G-05	SUB-ACHTB-22-H-05	NA	
* -06	-T	SUB-ACHTB-22-G-06	SUB-ACHTB-22-H-06	AC-P-C-H-ST-CA1	4
-01	-S	SUB-ACSHB-22-G-01	SUB-ACSHB-22-H-01	NA	
-02	-S	SUB-ACSHB-22-G-02	SUB-ACSHB-22-H-02	NA	
-03	-S	SUB-ACSHB-22-G-03	SUB-ACSHB-22-H-03	NA	
* -04	-S	ACSHB-22-6	ACSHB-22-6	AC-J-C-H-ST-CA1	6
-05	-S	SUB-ACSHB-22-G-05	SUB-ACSHB-22-H-05	NA	
* -06	-S	SUB-ACSHB-22-G-06	SUB-ACSHB-22-H-06	AC-J-C-H-ST-CA1	4

UNLESS OTHERWISE SPECIFIED, DIMENSIONS ARE IN MILLIMETERS. TOLERANCES ARE:
 DECIMALS ANGLES
 X.X: ±0.3 [.01] 2°
 X.XX: ±0.13 [.005]
 X.XXX: ±0.051 [.0020]

PROPRIETARY NOTE
 THIS DOCUMENT CONTAINS CONFIDENTIAL AND PROPRIETARY INFORMATION AND ALL DESIGN, MANUFACTURING, REPRODUCTION, USE, PATENT RIGHTS AND SALES RIGHTS ARE EXPRESSLY RESERVED BY SAMTEC, INC. THIS DOCUMENT SHALL NOT BE DISCLOSED, IN WHOLE OR PART, TO ANY UNAUTHORIZED PERSON OR ENTITY NOR REPRODUCED, TRANSFERRED OR INCORPORATED IN ANY OTHER PROJECT IN ANY MANNER WITHOUT THE EXPRESS WRITTEN CONSENT OF SAMTEC, INC.



520 PARK EAST BLVD, NEW ALBANY, IN 47150
 PHONE: 812-944-6733 FAX: 812-948-5047
 e-Mail: info@SAMTEC.com code 53322

MATERIAL: DO NOT SCALE DRAWING SHEET SCALE: 3:4
 CABLE SUB-ASM SHELLS/LOCKING SLEEVE/NUT: ZAMAK 3
 RETAINING RING: CARBON STEEL
 COLOR RING: SILICONE
 GROMMET CAGE: NYLON, COLOR: BLACK
 INSULATOR: PBT, COLOR: BLACK
 TERMINALS: BRASS
 CONTACTS: BRASS/BeCu
 GROMMET: NITRILE

DESCRIPTION:
 ACCLIMATE CIRC. FIELD TERM. KIT
 DWG. NO.
ACPK-22-XX-X-X-M-X
 BY: ROY LUO 6/17/2011 SHEET 1 OF 4

-T END OPTIONS

-01: 30 POS
Ø 1.0 TERMINALS

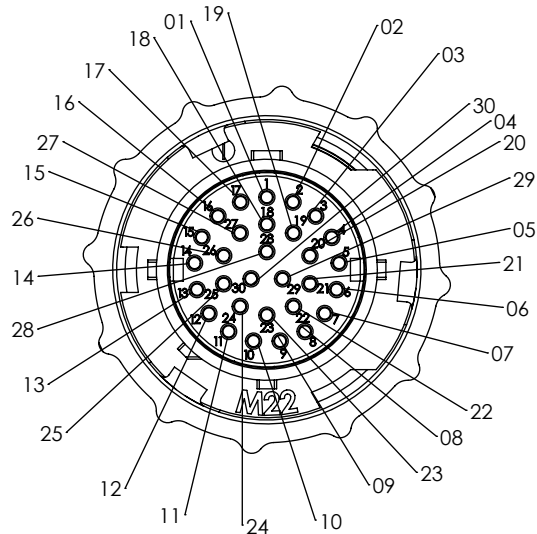

-02: 20 POS
Ø 1.0 TERMINALS

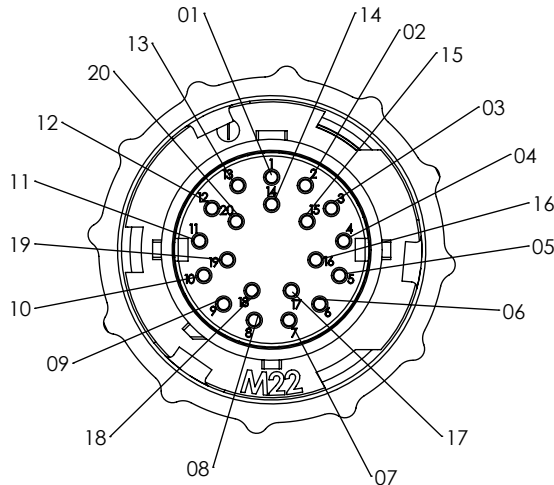

-03: 8 POS
Ø 1.5 TERMINALS

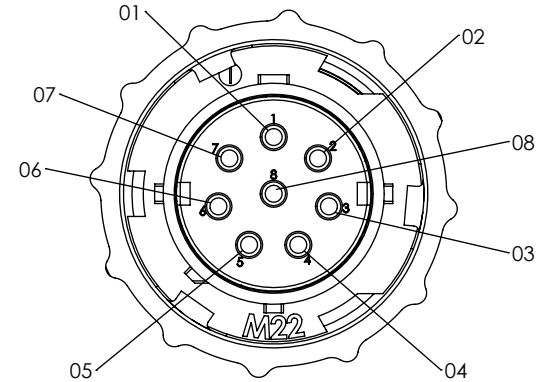

*-04: 6 POS
COAX PLUG

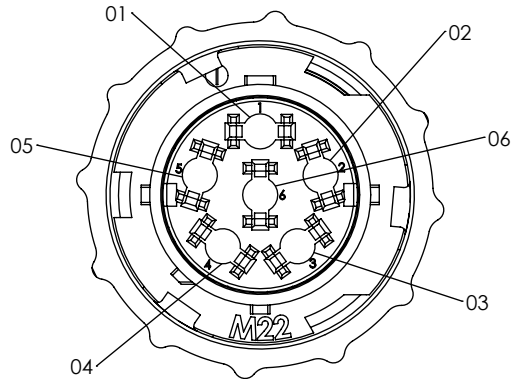

-05: 20 POS COMBO
4 X Ø 1.5 TERMINALS
16 X Ø 1.0 TERMINALS

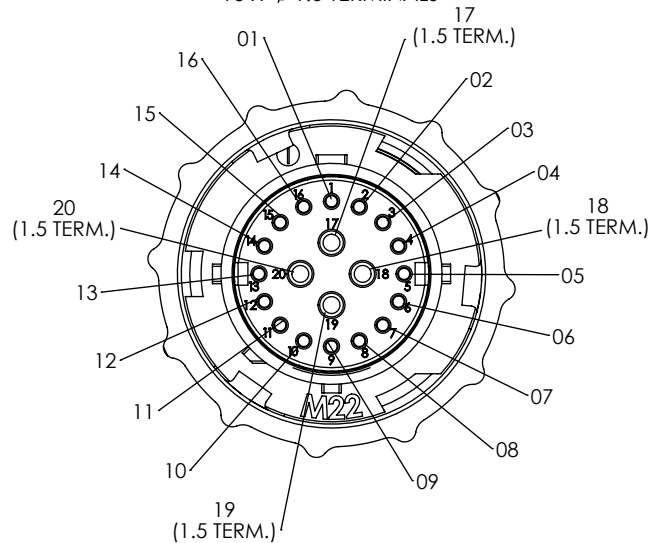

*-06: 16 POS COMBO
4 X COAX PLUG
12 X Ø 1.0 TERMINALS

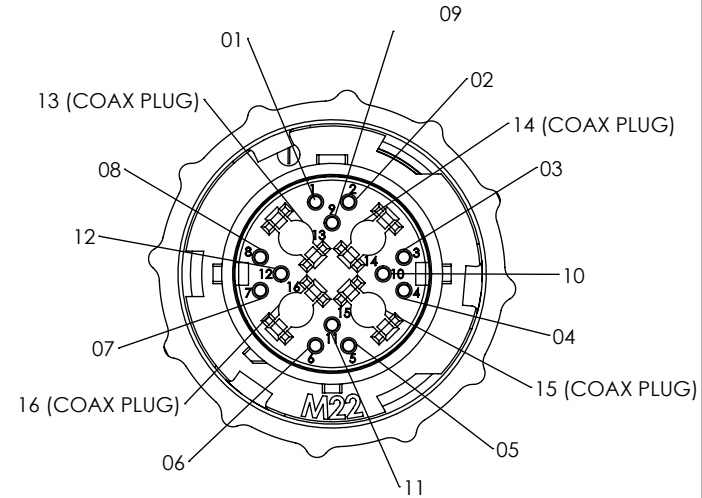

* = NOT RELEASED FOR PRODUCTION

<p>PROPRIETARY NOTE</p> <p>THIS DOCUMENT CONTAINS CONFIDENTIAL AND PROPRIETARY INFORMATION AND ALL DESIGN, MANUFACTURING, REPRODUCTION, USE, PATENT RIGHTS AND SALES RIGHTS ARE EXPRESSLY RESERVED BY SAMTEC, INC. THIS DOCUMENT SHALL NOT BE DISCLOSED, IN WHOLE OR PART, TO ANY UNAUTHORIZED PERSON OR ENTITY NOR REPRODUCED, TRANSFERRED OR INCORPORATED IN ANY OTHER PROJECT IN ANY MANNER WITHOUT THE EXPRESS WRITTEN CONSENT OF SAMTEC, INC.</p> <p>DO NOT SCALE DRAWING</p> <p>SHEET SCALE: 3:2</p>	 <p>520 PARK EAST BLVD. NEW ALBANY, IN 47150 PHONE: 812-944-6733 FAX: 812-948-5047 e-Mail info@SAMTEC.com code 55322</p>	
	<p>DESCRIPTION: ACCLIMATE CIRC. FIELD TERM. KIT</p>	
	<p>DWG. NO. ACPK-22-XX-X-X-M-X</p>	
	<p>BY: ROY LUO 6/17/2011</p>	<p>SHEET 2 OF 4</p>

-S END OPTIONS

-01: 30 POS
Ø 1.0 SOCKETS

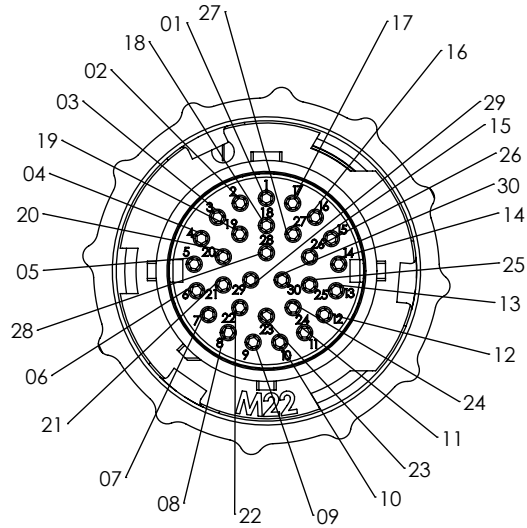

-02: 20 POS
Ø 1.0 SOCKETS

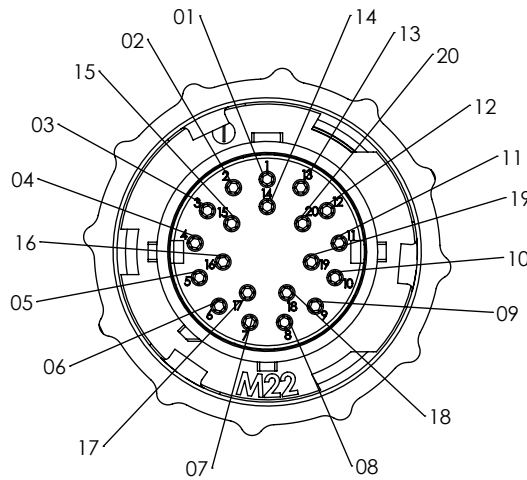

-03: 8 POS
Ø 1.5 SOCKETS

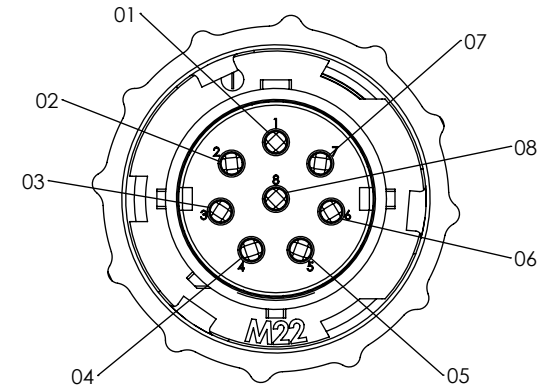

*-04: 6 POS
COAX JACK

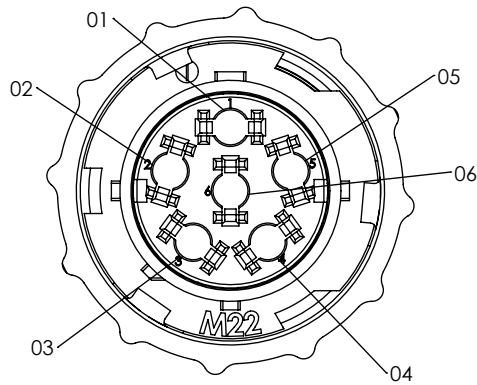

-05: 20 POS COMBO
4 X Ø 1.5 SOCKETS
16 X Ø 1.0 SOCKETS

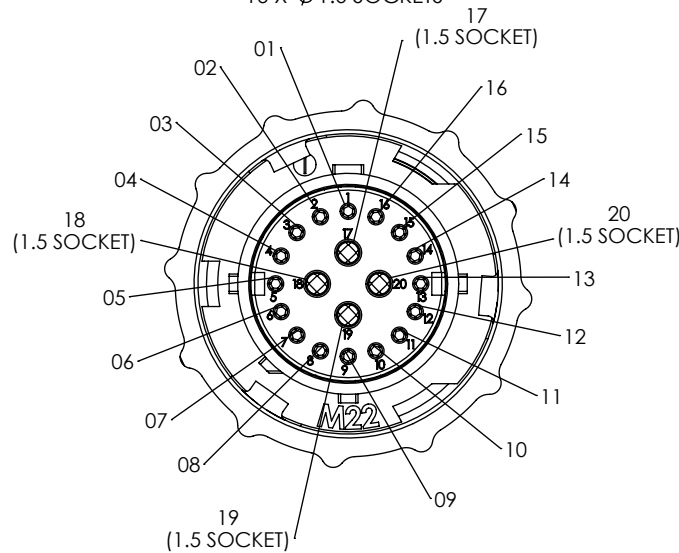

*-06: 16 POS COMBO
4 X COAX JACK
12 X Ø 1.0 SOCKETS

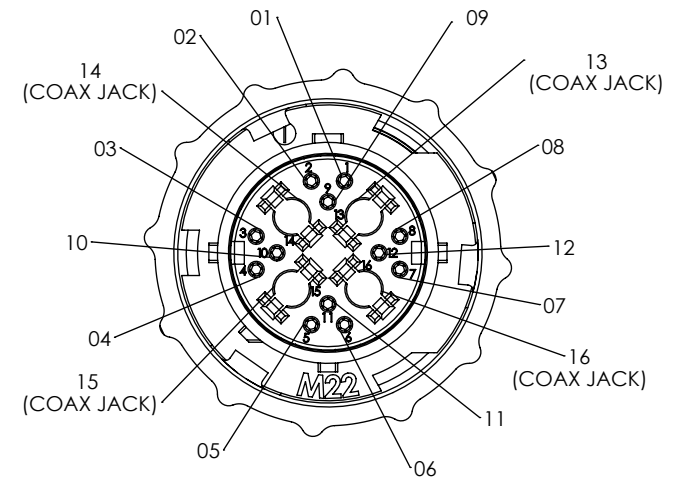

* = NOT RELEASED FOR PRODUCTION

PROPRIETARY NOTE
THIS DOCUMENT CONTAINS CONFIDENTIAL AND PROPRIETARY INFORMATION AND ALL DESIGN, MANUFACTURING, REPRODUCTION, USE, PATENT RIGHTS AND SALES RIGHTS ARE EXPRESSLY RESERVED BY SAMTEC, INC. THIS DOCUMENT SHALL NOT BE DISCLOSED, IN WHOLE OR PART, TO ANY UNAUTHORIZED PERSON OR ENTITY NOR REPRODUCED, TRANSFERRED OR INCORPORATED IN ANY OTHER PROJECT IN ANY MANNER WITHOUT THE EXPRESS WRITTEN CONSENT OF SAMTEC, INC.

DO NOT SCALE DRAWING

SHEET SCALE: 3:2

samtec

520 PARK EAST BLVD. NEW ALBANY, IN 47150
PHONE: 812-944-6733 FAX: 812-948-5047
e-Mail: info@SAMTEC.com code 55322

DESCRIPTION: ACCLIMATE CIRC. FIELD TERM. KIT

DWG. NO. ACPK-22-XX-X-X-M-X

BY: ROY LUO 6/17/2011 SHEET 3 OF 4

KEY FEATURE
(SEE NOTE 2)

-1
ORANGE KEY RING

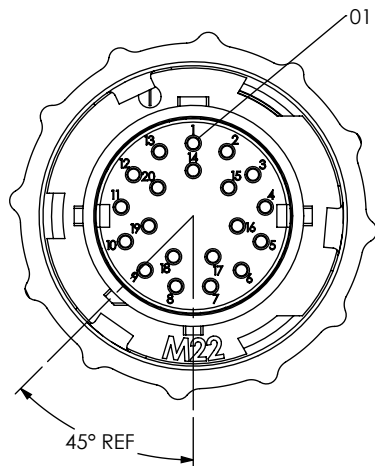

-2
GREEN KEY RING

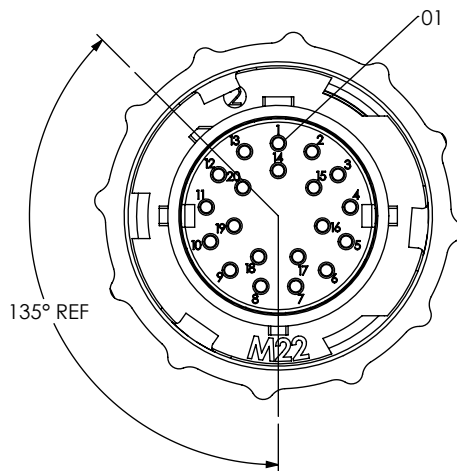

-3
BLUE KEY RING

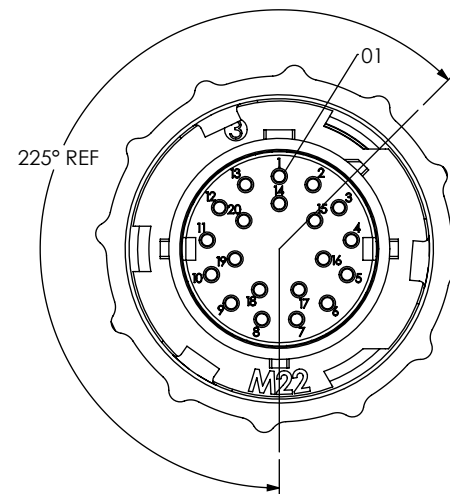

-4
YELLOW KEY RING

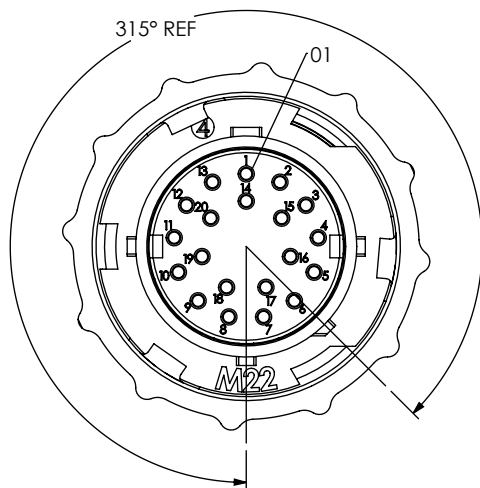

PROPRIETARY NOTE
THIS DOCUMENT CONTAINS CONFIDENTIAL AND PROPRIETARY INFORMATION AND ALL DESIGN, MANUFACTURING, REPRODUCTION, USE, PATENT RIGHTS AND SALES RIGHTS ARE EXPRESSLY RESERVED BY SAMTEC, INC. THIS DOCUMENT SHALL NOT BE DISCLOSED, IN WHOLE OR PART, TO ANY UNAUTHORIZED PERSON OR ENTITY NOR REPRODUCED, TRANSFERRED OR INCORPORATED IN ANY OTHER PROJECT IN ANY MANNER WITHOUT THE EXPRESS WRITTEN CONSENT OF SAMTEC, INC.

DO NOT SCALE DRAWING

SHEET SCALE: 1.5:1

samtec

520 PARK EAST BLVD. NEW ALBANY, IN 47150
PHONE: 812-944-6733 FAX: 812-948-5047
e-Mail info@SAMTEC.com code 55322

DESCRIPTION: ACCLIMATE CIRC. FIELD TERM. KIT

DWG. NO. ACPK-22-XX-X-X-M-X

BY: ROY LUO 6/17/2011 SHEET 4 OF 4