

THIS DRAWING IS UNPUBLISHED. RELEASED FOR PUBLICATION. COPYRIGHT BY TYCO ELECTRONICS CORPORATION. ALL RIGHTS RESERVED.

| PART NUMBER | REV | FIRST USED |
|-------------|-----|------------|
| 680874-1 | E | 122500-1 |
| 680874-2 | E | 565435-5 |
| 680874-3 | E | 354500-1 |

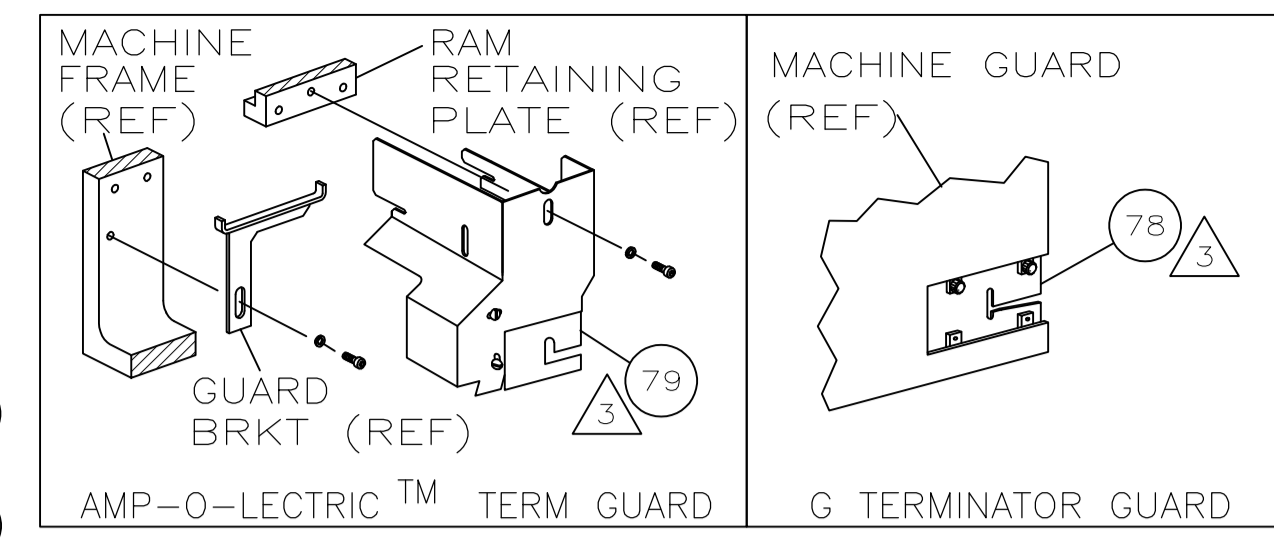

| TERMINAL NAME: TERMINAL SOCKET | | CRIMP DATA (NON-AMP TERMINAL-AMP SPEC) | | | |
|--------------------------------|----------------|--|--------------------------|-------------|--------|
| AMP | MFG | PAD LTR | CRIMP HEIGHT | WIRE SIZE | |
| 286833 | 12084912 | A | .053 ±.002 [1.34 ±.05mm] | 18 | |
| | | B | NOT | USED | |
| | | C | NOT | USED | |
| | | D | NOT | USED | |
| CRIMP | SIZE | TYPE | RANGE | | |
| | .070 [1.78mm] | F | 18 | | |
| WIRE | INSUL | | | | |
| | .080 [2.03mm] | F | .080 MAX | | |
| WIRE STRIP LENGTH | TERM APPL SPEC | FEED | APPL INSTRUCTION | SET UP GAGE | LAYOUT |
| .1875-.219 | NONE | .315 | 408-8040 | 458637-1 | L2282 |

| LOC | DIST | REVISIONS | | | |
|-----|------|---------------|--------|----|------|
| F | LTR | DESCRIPTION | DATE | BY | APPV |
| A | 66 | ECR-07-010264 | 5-2007 | MY | TE |

| | | |
|----|---------------|----------------|
| -1 | LEADMAKER | MECH POST FEED |
| -2 | BENCH MODEL K | MECH PRE FEED |
| -3 | BENCH MODEL G | MECH PRE FEED |

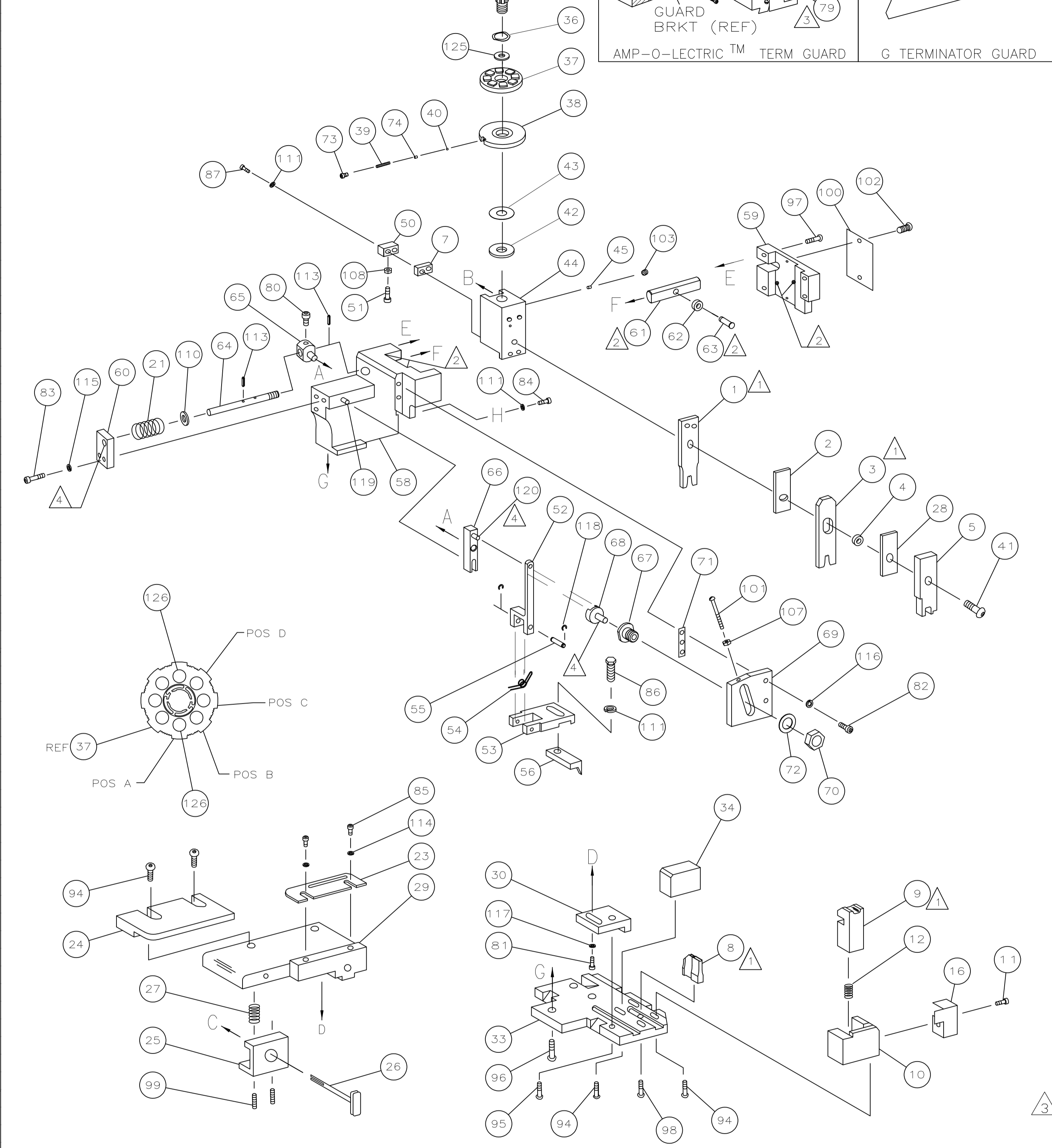

| QTY | REF | REF | REF | REF | DESCRIPTION | ITEM NO |
|-----|-----|-----|-----|------------|---------------------------------|---------|
| 2 | 2 | 2 | - | 2-354779-2 | PIN, WIRE DISK ".3100"A | 126 |
| 1 | 1 | 1 | - | 986950-1 | WASHER, FLAT PRECISION | 125 |
| 1 | 1 | 1 | - | 217238-1 | GENERAL INSTRUCTION PACKAGE | 124 |
| 1 | 1 | 1 | - | 4088040 | SF APPL INST 408-8040 | 123 |
| REF | REF | REF | - | 1-21030-1 | PIN,DOWEL(Ø.187x.50)LEVER | 122 |
| REF | REF | REF | - | 1-21030-6 | PIN,DOWEL(Ø.187x1.25)HOUSING | 121 |
| REF | REF | REF | - | 21045-3 | RING,RET "C"(Ø.187)FD FING PIN | 120 |
| 1 | 1 | 1 | - | 21024-5 | WASHER, LOCK(#10)ADJ BLOCK | 119 |
| REF | REF | REF | - | 21024-5 | WASHER,LOCK(#10)ADJ PLATE | 118 |
| REF | REF | REF | - | 21024-5 | WASHER,LOCK(#10)FEED GDE ROD | 117 |
| 2 | 2 | 2 | - | 21024-2 | WASHER,LOCK(#4)FRONT STP GUIDE | 116 |
| REF | REF | REF | - | 5-21028-1 | PIN,SLT SPR(Ø.125x.50)ADJ ROD | 115 |
| 4 | 4 | 4 | - | 21024-4 | WASHER,LOCK(#8)STRIPPER | 114 |
| REF | REF | REF | - | 21899-4 | WASHER,FLAT(Ø5/16)SCREW ADJ | 113 |
| 1 | 1 | 1 | - | 21018-5 | NUT,HEX(NO.6)HOLDDOWN | 112 |
| REF | REF | REF | - | 21068-5 | NUT,HEX(6-32)FEED ADJ | 111 |
| 1 | 1 | 1 | - | 21009-2 | SCR,SKT SET(1/4-20x.25 LW)RAM | 110 |
| 2 | 2 | 2 | - | 21017-2 | SCR,DRIVE(#2x.19)ID PLATE | 109 |
| REF | REF | REF | - | 6-23715-5 | SCR,PAN HD(6-32x1.50)FEED ADJ | 108 |
| 1 | 1 | 1 | - | 461264-1 | PLATE, IDENTIFICATION | 107 |
| 2 | 2 | 2 | - | 5-21006-6 | SCR,SET(10-32x.75)DRAG | 106 |
| 1 | 1 | 1 | - | 22733-8 | SCR,BHC(8-32x.38 LW)ANVIL | 105 |
| REF | REF | REF | - | 2-21002-9 | SCR,BHC(10-32x.75)CAP | 104 |
| REF | REF | REF | - | 2-22733-8 | SCR,BHC(1/4-20x.62)HOUSING | 103 |
| REF | REF | REF | - | 2-21002-7 | SCR,BHC(10-32x.50)SG ADJ BLOCK | 102 |
| 6 | 6 | 6 | - | 2-21002-2 | SCR,BHC(8-32x.50)TERM H DWN | 101 |
| 1 | 1 | 1 | - | 1-21002-7 | SCR,BHC(6-32x.38)CAM | 100 |
| 2 | 2 | 2 | - | 2-21000-8 | SCR,SHC(8-32x.63) | 99 |
| 1 | 1 | 1 | - | 2-22603-0 | SCR,HEX HD(8-32x.31)FEED FINGER | 98 |
| 2 | 2 | 2 | - | 1-21000-3 | SCR,SHC(4-40x.25)F ST GUIDE | 97 |
| 1 | 1 | 1 | - | 2-21000-7 | SCR,SHC(8-32x.50)STRIPPER | 96 |
| REF | REF | REF | - | 3-21000-7 | SCR,SHC(10-32x.75)FEED ROD GD | 95 |
| REF | REF | REF | - | 3-21000-6 | SCR,SHC(10-32x.62)FD ADJ BLK | 94 |
| 1 | 1 | 1 | - | 3-21000-4 | SCR,SHC(10-32x.38)SG ADJ BL | 93 |
| REF | REF | REF | - | 3-21000-4 | SCR,SHC(10-32x.38)PIVOT BLK | 92 |
| - | REF | - | - | 455749-1 | GUARD, WINDOW | 91 |
| REF | - | - | - | 679532-1 | INSERT, GUARD | 90 |
| 1 | 1 | 1 | - | 690603-1 | SPRING, ASSIST | 89 |
| 1 | 1 | 1 | - | 23030-1 | SCR,SHC(6-32x.25 SL)INS DISC | 88 |
| REF | REF | REF | - | 458109-1 | WASHER, SPECIAL | 87 |
| REF | REF | REF | - | 690517-1 | SPACER | 86 |
| -3 | -2 | -1 | U/M | PART NO | DESCRIPTION | ITEM NO |

| QTY | REF | REF | REF | REF | DESCRIPTION | ITEM NO |
|-----|-----|-----|-----|------------|-----------------------------|---------|
| 1 | 1 | 1 | - | 458537-2 | PAWL, FEED | 129 |
| REF | REF | REF | - | 240628-1 | PLATE, ADJUSTMENT | 128 |
| REF | REF | REF | - | 240626-1 | SHAFT, PIVOT | 127 |
| REF | REF | REF | - | 240633-1 | BUSHING | 126 |
| REF | REF | REF | - | 455680-1 | LEVER, INTERMEDIATE | 125 |
| REF | REF | REF | - | 240629-1 | BLOCK, PIVOT | 124 |
| REF | REF | REF | - | 240632-2 | SCREW, ADJ FEED ROD | 123 |
| REF | REF | REF | - | 240659-3 | PIN, CAM ROLLER | 122 |
| REF | REF | REF | - | 240658-1 | ROLLER, CAM | 121 |
| REF | REF | REF | - | 454398-2 | ROD, FEED | 120 |
| REF | REF | REF | - | 454178-1 | GUIDE, FEED ROD | 119 |
| REF | REF | REF | - | 454220-1 | CAP, RAM | 118 |
| REF | REF | REF | - | 454485-1 | HOUSING | 117 |
| 1 | 1 | 1 | - | 458537-2 | PAWL, FEED | 129 |
| REF | REF | REF | - | 240624-1 | PIN, FEED FINGER | 126 |
| REF | REF | REF | - | 691499-1 | SPRING, FEED FINGER | 125 |
| REF | REF | REF | - | 690541-1 | HOLDER, FEED FINGER | 124 |
| REF | REF | REF | - | 455679-1 | LEVER, TERMINAL FEED ARM | 123 |
| 1 | 1 | 1 | - | 811242-2 | BUMPER, HOLDDOWN | 122 |
| 1 | 1 | 1 | - | 690753-1 | SPACER, TONKER | 121 |
| 1 | - | - | - | 690602-6 | CAM, PRE-FEED 1 5/8 ST | 120 |
| - | 1 | - | - | 690602-5 | CAM, PRE-FEED 1 1/8 ST | 119 |
| - | - | 1 | - | 690501-4 | CAM, POST-FEED 1 5/8 ST | 118 |
| 1 | 1 | 1 | - | 459456-1 | APPLICATOR, BASIC (SUBASSY) | 117 |
| 1 | 1 | 1 | - | 690191-1 | PLUG, NYLON | 116 |
| 1 | 1 | 1 | - | 455673-1 | RAM | 115 |
| 1 | 1 | 1 | - | 690125-1 | WASHER, LAMINATED | 114 |
| 1 | 1 | 1 | - | 690124-1 | WASHER, RAM | 113 |
| 1 | 1 | 1 | - | 7-21002-9 | BOLT, CRIMPER(5/16x1.00) | 112 |
| 1 | 1 | 1 | - | 23241-6 | BALL, STEEL | 111 |
| 1 | 1 | 1 | - | 690170-1 | SPRING, COMPRESSION | 110 |
| 1 | 1 | 1 | - | 690142-1 | DISC, INSULATION | 109 |
| 1 | 1 | 1 | - | 354777-1 | WIRE DISC, PLASTIC | 108 |
| 1 | 1 | 1 | - | 22480-5 | WASHER, SPRING | 107 |
| 1 | 1 | 1 | - | 690212-1 | POST, RAM | 106 |
| 1 | 1 | 1 | - | 690786-1 | SUPPORT, TERMINAL | 105 |
| REF | REF | REF | - | 455675-1 | PLATE, BASE | 104 |
| REF | REF | REF | - | 455689-1 | BLOCK, STRIP GUIDE ADJ | 103 |
| 1 | 1 | 1 | - | 318756-1 | PLATE, STRIP GUIDE ASSY | 102 |
| 1 | 1 | 1 | - | 2-455888-2 | SPACER, FRONT SHEAR DEP | 101 |
| 2 | 2 | 2 | - | 1-22284-0 | SPRING, DRAG | 100 |
| 1 | 1 | 1 | - | 690546-1 | LEVER, DRAG RELEASE | 99 |
| 1 | 1 | 1 | - | 240792-1 | DRAG, TERMINAL | 98 |
| 1 | 1 | 1 | - | 6-690504-0 | GUIDE, STRIP (REAR) | 97 |
| 1 | 1 | 1 | - | 690438-1 | GUIDE, STRIP (FRONT) | 96 |
| - | - | 1 | - | 690472-2 | STRIPPER | 95 |
| REF | REF | REF | - | 4-22284-9 | SPRING, FEED RETURN | 94 |
| 1 | 1 | - | - | 691353-1 | STRIPPER | 93 |
| 1 | 1 | 1 | - | 318563-1 | GUARD, CHIP, FRONT | 92 |
| 1 | 1 | 1 | - | 3-22280-3 | SPRING, SHEAR | 91 |
| 1 | 1 | 1 | - | 690461-1 | STOP, SHEAR | 90 |
| 1 | 1 | 1 | - | 690459-1 | HOLDER, SHEAR (FRONT) | 89 |
| 1 | 1 | 1 | - | 454276-1 | SHEAR, FLOAT (FRONT) | 88 |
| 1 | 1 | 1 | - | 2-662185-6 | ANVIL | 87 |
| 1 | 1 | 1 | - | 2-240641-4 | SPACER, DEPRESSOR (REAR) | 86 |
| 1 | 1 | 1 | - | 1-455889-4 | DEPRESSOR, SHEAR (FRONT) | 85 |
| 1 | 1 | 1 | - | 2-238011-2 | SPACER, BLOCK CRIMPER | 84 |
| 1 | 1 | 1 | - | 5-456134-4 | CRIMPER, INSULATION | 83 |
| 1 | 1 | 1 | - | 1-455888-0 | SPACER, CRIMPER | 82 |
| 1 | 1 | 1 | - | 4-456404-3 | CRIMPER, WIRE | 81 |
| -3 | -2 | -1 | U/M | PART NO | DESCRIPTION | ITEM NO |

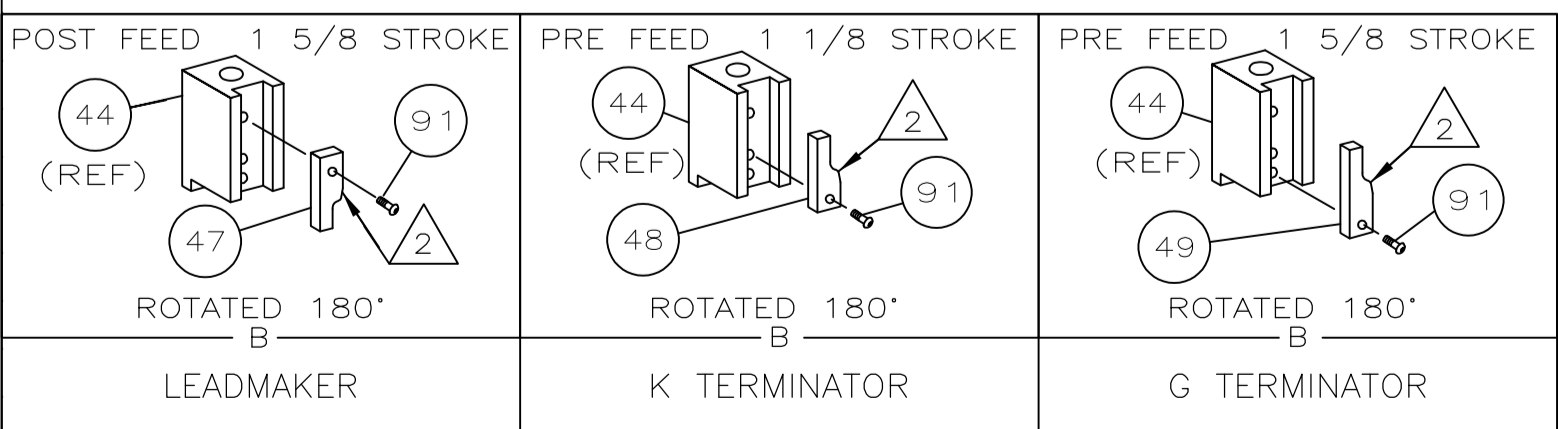

- 1 RECOMMENDED SPARE PARTS.
 - 2 GREASE LIGHTLY.
 - 3 GUARD MUST BE IN PLACE WHEN OPERATING APPLICATOR IN A BENCH MACHINE.
 - 4 LUBRICATE DAILY USING NO. 20 MACHINE OIL.
5. ITEMS WITH QTY OF REF SPECIFIED (EXCEPT ITEMS 78 AND 79) ARE USED ON ITEM 46.

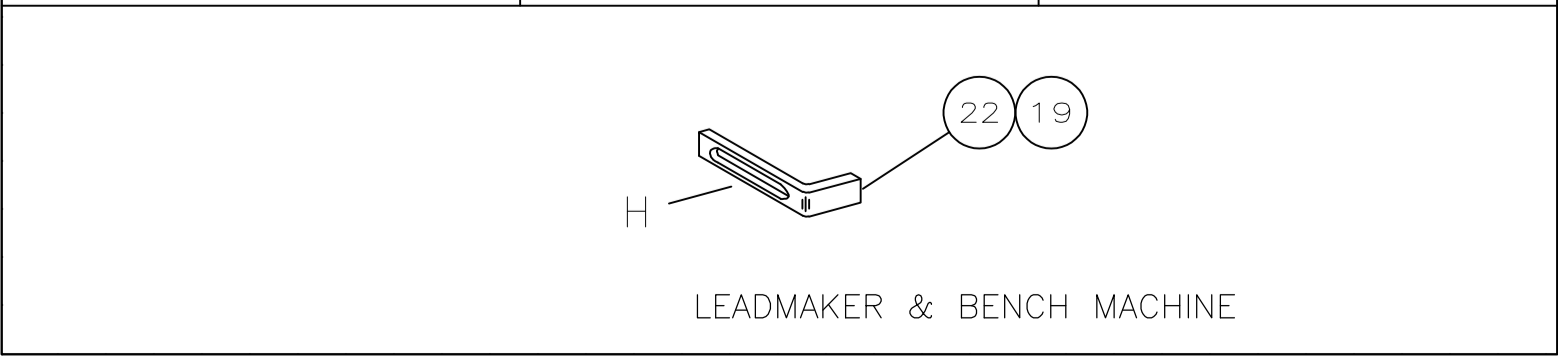

| DIMENSIONS: INCHES | | TOLERANCES UNLESS OTHERWISE SPECIFIED: | | MATERIAL | | FINISH | |
|--------------------|---------|--|--------|----------|--------|--------|---------|
| 0 PLC | ± .005 | 1 PLC | ± .002 | 2 PLC | ± .001 | 3 PLC | ± .0005 |
| 4 PLC | ± .0002 | ANGLES | ± .001 | | | | |

| | | | | | |
|--|--|------------|-----------|---|---------------|
| THIS DRAWING IS A CONTROLLED DOCUMENT. | | DIN T.KINT | 19AUG99 | Tyco Electronics Corporation Harrisburg, PA 17105-3608 | |
| APVD T.ELBIN | | 19AUG99 | NAME | SIDE FEED HDM APPLICATOR | |
| APPLICATION SPEC | | SIZE | CAGE CODE | DRAWING NO | RESTRICTED TO |
| WEIGHT | | A1 | 00779 | 680874 | |
| CUSTOMER DRAWING | | SCALE | SHEET | 1 of 1 | REV E |