

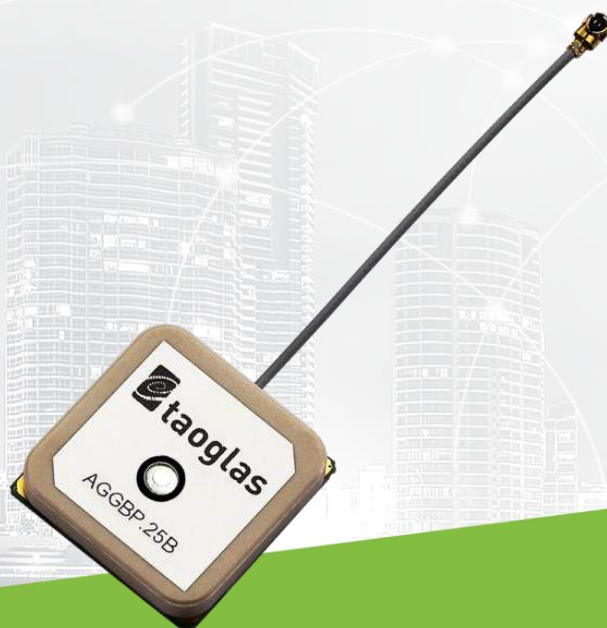

TAOGLAS®



Datasheet

Part No:
AGGBP.25B.07.0060A

Description

25x25mm Two Stage GPS-GLONASS-GALILEO-BeiDou
Embedded Active Patch Antenna Module with Front-End SAW Filter

Features:

- Full GPS-GLONASS-GALILEO-BeiDou Coverage
- 28dB two stage LNA
- Ceramic patch Element
- Front-end SAW filter to reduce out of band noise
- Wide input voltage 1.8V to 5.5V
- 25.1 x 25.1 x 7.9mm
- 60mm Ø1.13 IPEX MHFI (U.FL)
- Automotive TS16949 Production and Quality Approved
- Cable length and connector type customizable
- RoHS Compliant

1.	Introduction	2
2.	Specification	3
3.	Passive Antenna Characteristics	5
4.	Radiation Patterns	9
5.	LNA Characteristics	13
6.	Mechanical Drawing	15
7.	Packaging	16
<hr/>		
	Changelog	17

Taoglas makes no warranties based on the accuracy or completeness of the contents of this document and reserves the right to make changes to specifications and product descriptions at any time without notice. Taoglas reserves all rights to this document and the information contained herein. Reproduction, use or disclosure to third parties without express permission is strictly prohibited.



1. Introduction



The AGGBP.25B is an internal GPS/GLONASS/GALILEO/BeiDou active patch antenna with $\varnothing 1.13$ cable and IPEX MHFI connector. It is the ideal antenna for next generation GNSS devices to achieve good sensitivity across all bands in a small form factor.

The active patch antenna, by means of a double resonance design, has a wide-band operation over GPS/GLONASS/GALILEO/BeiDou systems from 1561MHz to 1606MHz. It includes a two-stage LNA and front-end SAW filter to reduce out of band noise, such as from nearby cellular transceivers. This antenna offers better protection from nearby radiated power surges and greatly reduces the probability of damaging your GPS/GLONASS/BeiDou receiver due to nearby transmissions.

The patch, the ground plane, the LNA, and front-end SAW components are all integrated in a dimension of 25.1 x 25.1 x 7.9 mm, connecting with a $\varnothing 1.13$ 60mm long coaxial cable and an IPEX MHFI connector. The AGGBP.25B is manufactured and tested in a TS16949 first tier automotive approved facility. The cable length and connector type can be adjusted for a MOQ.

For further optimization to customer specific device environments, custom tuned patch antennas can be supplied, again to a MOQ. For more details please contact your regional Taoglas sales office.

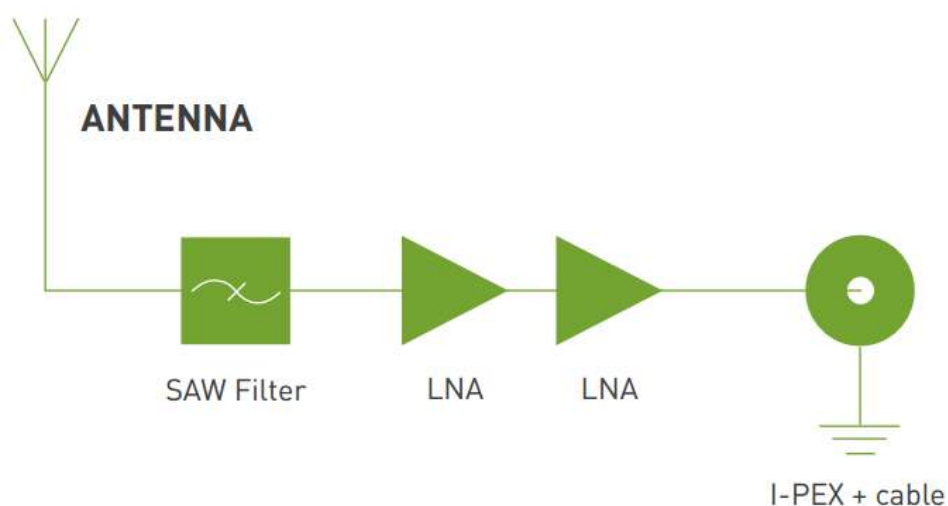

2. Specification

GNSS Frequency Bands					
GPS	L1 1575.42 MHz	L2 1227.6 MHz	L5 1176.45 MHz		
	■	□	□		
GLONASS	G1 1602 MHz	G2 1248 MHz	G3 1207 MHz		
	■	□	□		
Galileo	E1 1575.24 MHz	E5a 1176.45 MHz	E5b 1201.5 MHz	E6 1278.75 MHz	
	■	□	□	□	
BeiDou	B1C 1575.42 MHz	B1I 1561 MHz	B2a 1176.45 MHz	B2b 1207.14 MHz	B3 1268.52 MHz
	■	■	□	□	□
L-Band	L-Band 1542 MHz				
	□				
QZSS (Regional)	L1 1575.42 MHz	L2C 1227.6 MHz	L5 1176.45 MHz	L6 1278.75e6	
	■	□	□	□	
IRNSS (Regional)	L5 1176.45 MHz				
	□				
SBAS	L1/E1/B1 1575.42 MHz	L5/B2a/E5a 1176.45 MHz	G1 1602 MHz	G2 1248 MHz	G3 1207 MHz
	■	□	■	□	□

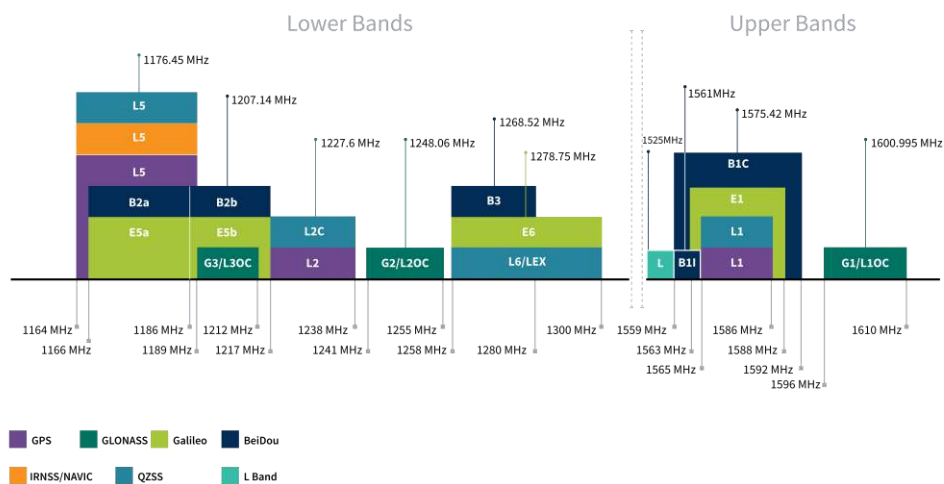

GNSS Bands and Constellations

GNSS Electrical

Frequency (MHz)	1561	1575.42	1602
Passive Antenna Efficiency (%)	37	64	81
Gain (dBi)	-0.6	1.0	2.9
Group Delay Mean (ns)	12.0	9.9	10.5
Impedance	50 Ω		

LNA and Filter Electrical Properties

Frequency (MHz)	1561	1575.42	1602
Gain@3.0V (dB)	28.9	30.3	29.3
Noise Figure@3.0V (dB)	3.1	2.5	2.8
P1dB@3.0V (dBm)	-30.5	-32.0	-31.0

Mechanical

Ceramic Dimension	25.1 x 25.1 x 4.7mm
Total Dimension (including shielding case)	25.1 x 25.1 x 7.9mm
Connector	IPEX MHFI (U.FL)
Cable	Coaxial cable \varnothing 1.13, length 60mm
Weight (grams)	11.46

Environmental

Operation Temperature	-40°C to 85°C
Storage Temperature	-40°C to + 85°C
Humidity	Non-condensing 65°C 95% RH

3. Passive Antenna Characteristics

3.1 Test Setup

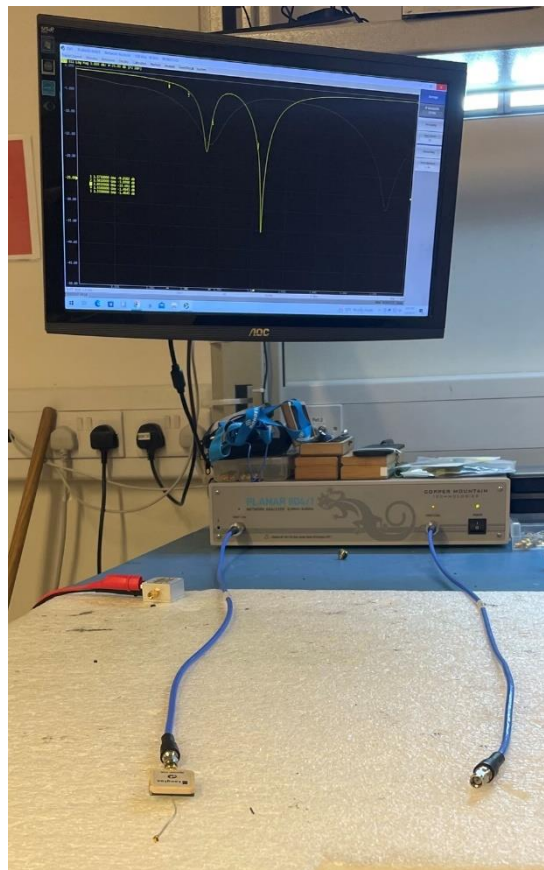
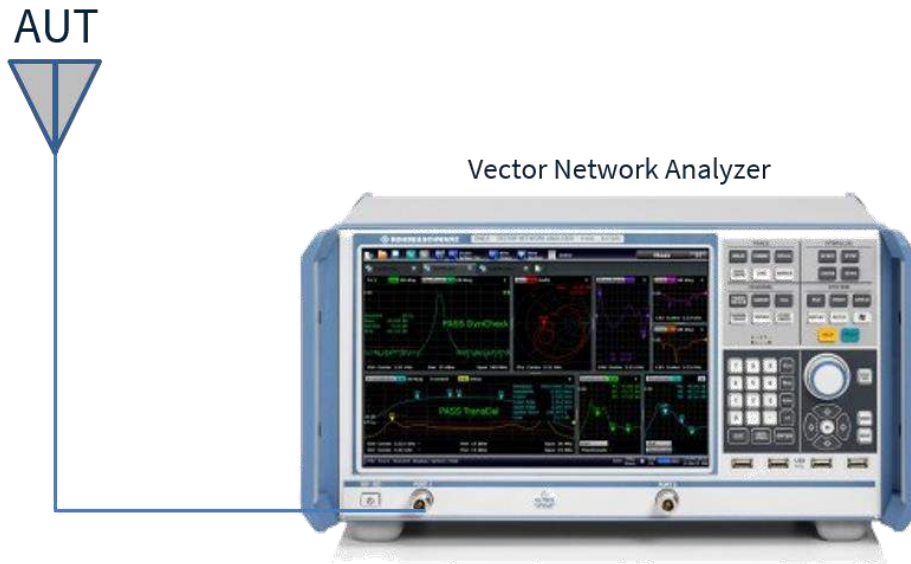

3.2 Return Loss

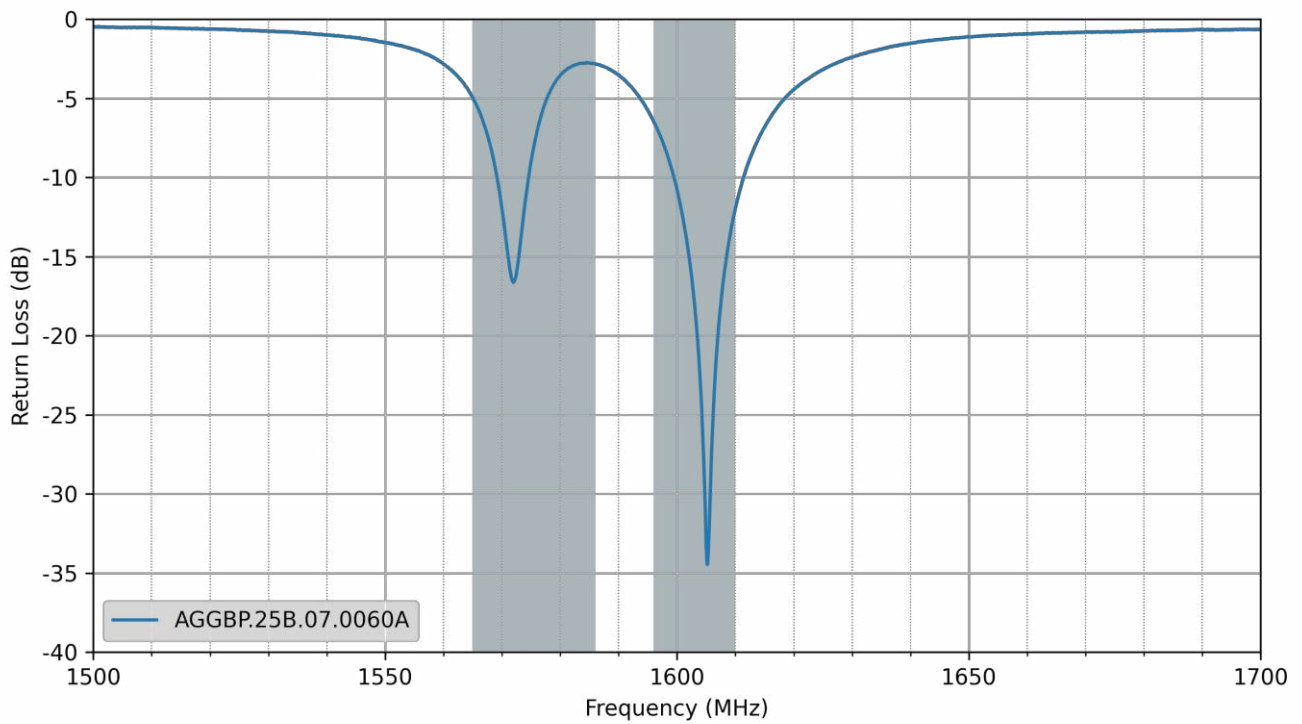

3.3 VSWR

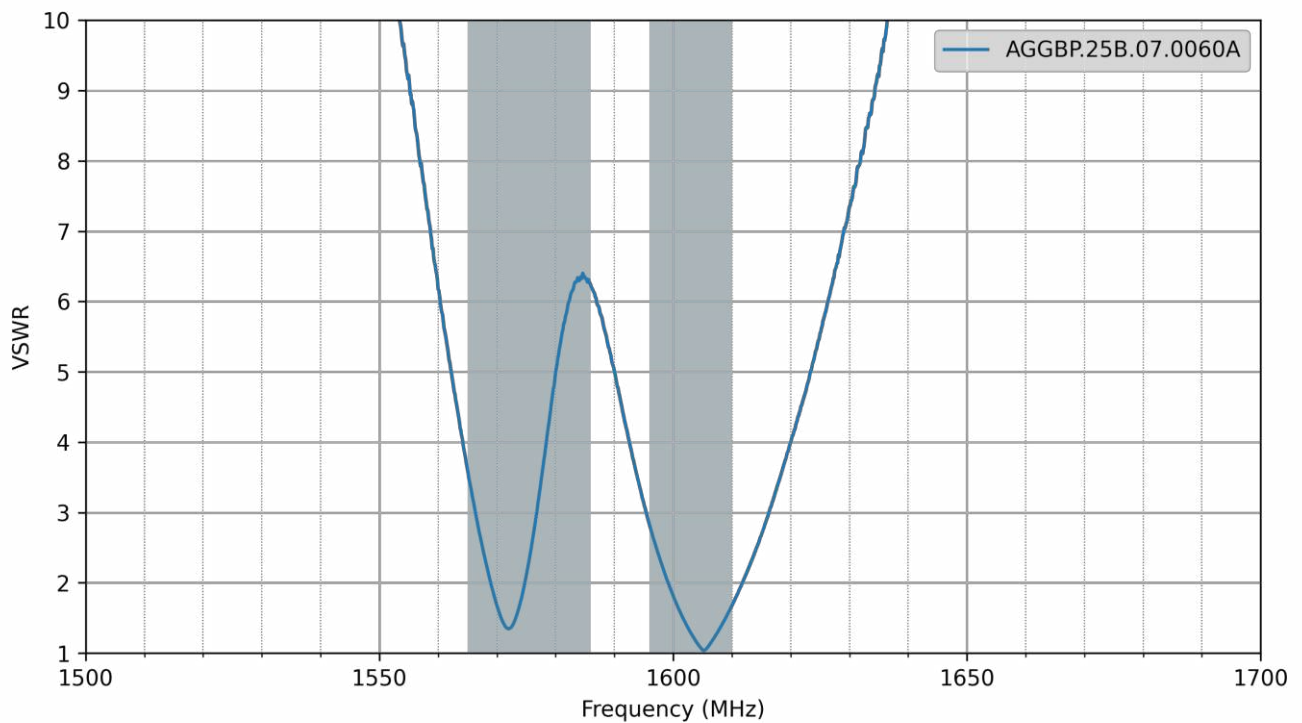

3.4 Efficiency

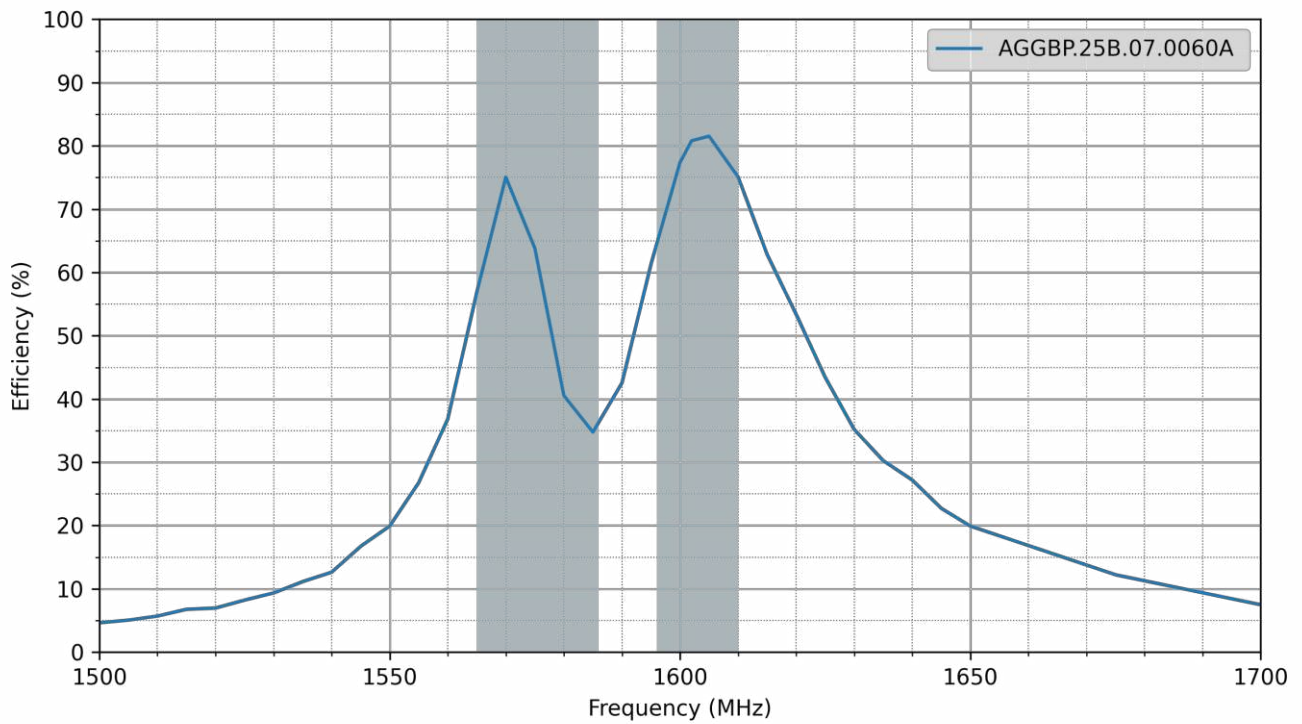

3.5 Average Gain

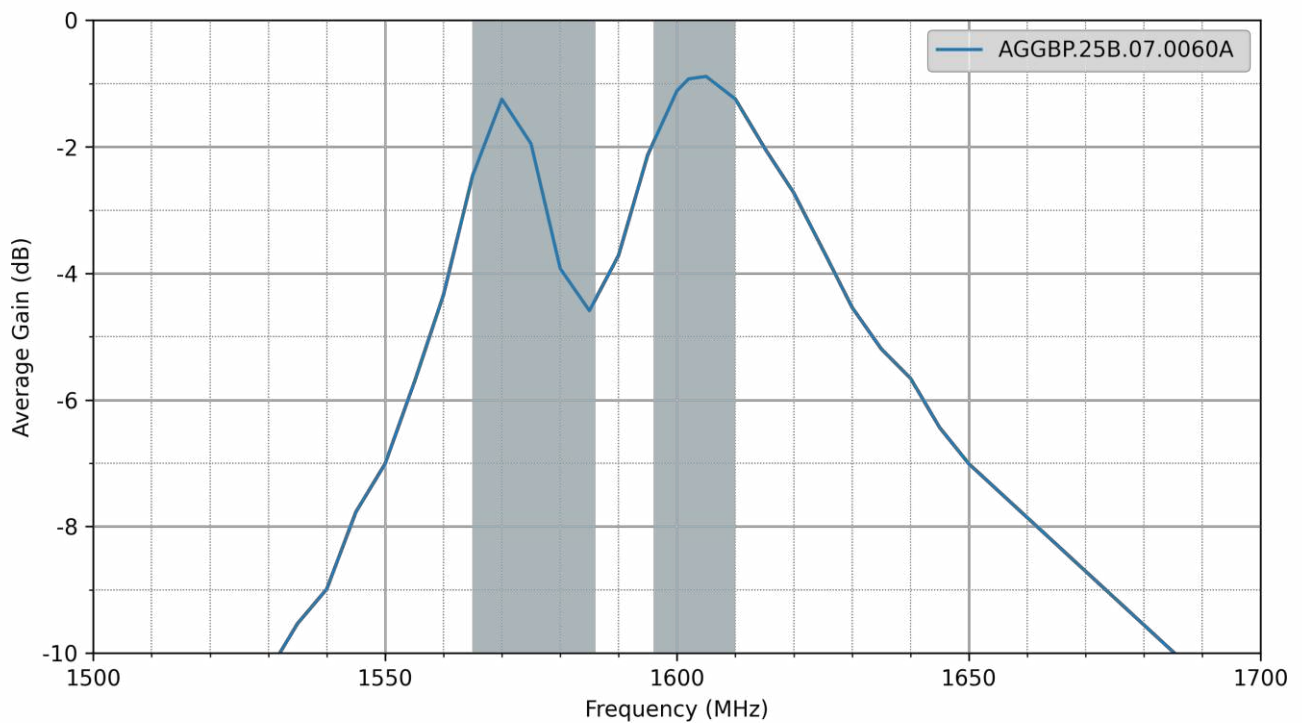

3.6 Peak Gain

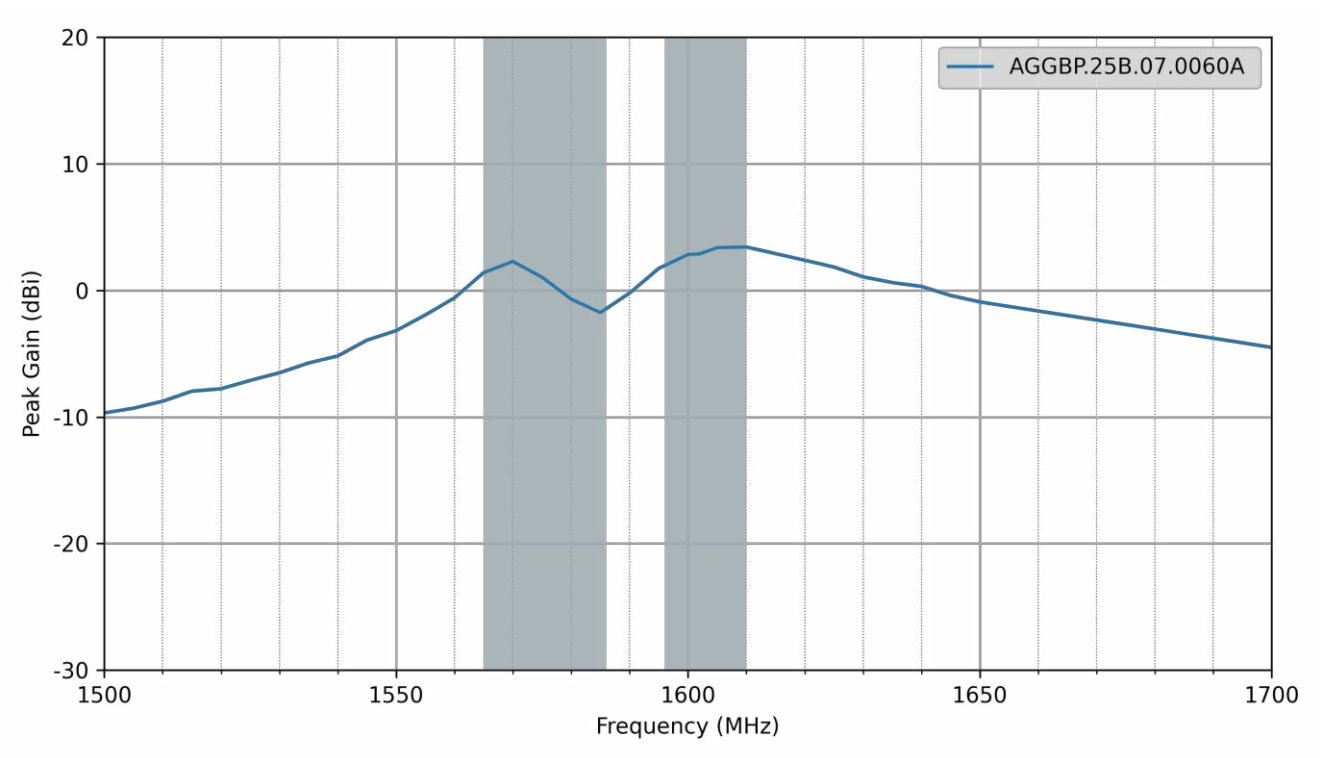

4. Radiation Patterns

4.1 Test Setup

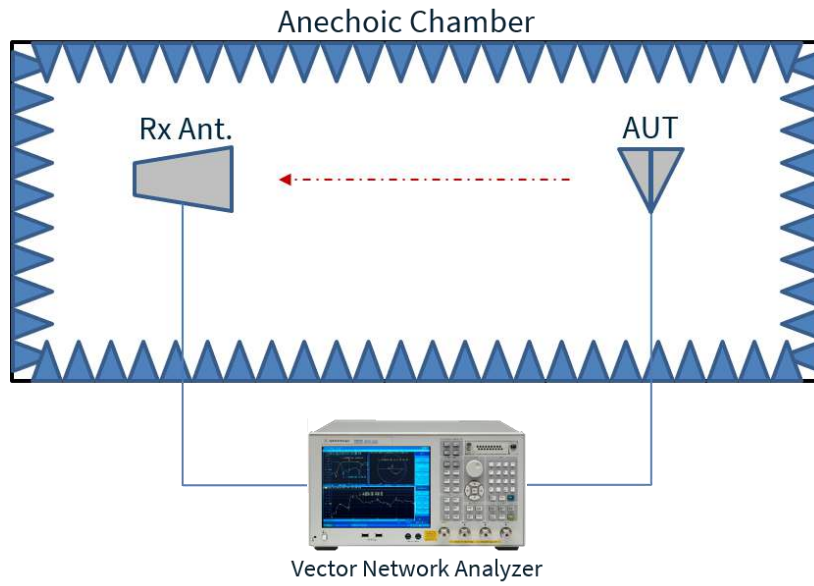

4.1 AGGBP.25B.07.0060A Patterns at 1560 MHz

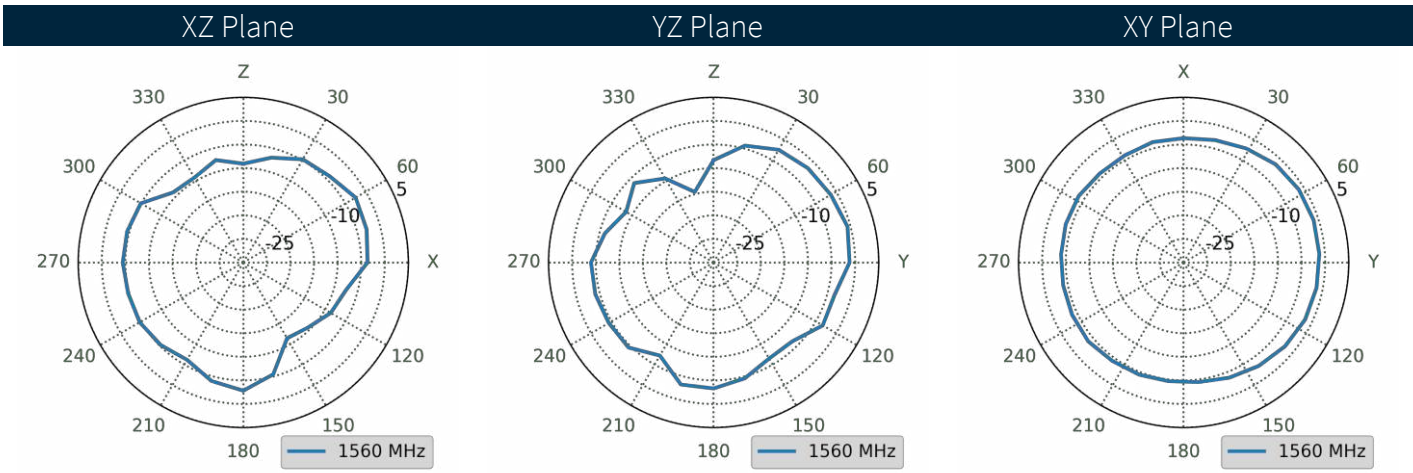
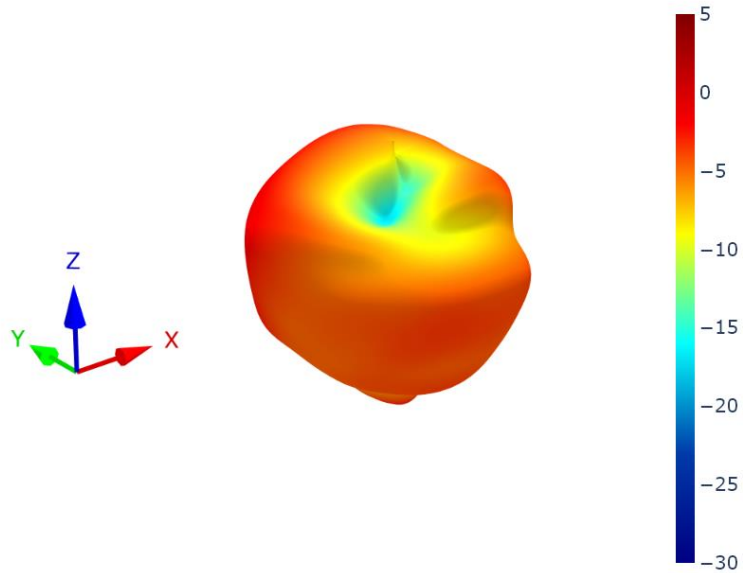

4.2 AGGBP.25B.07.0060A Patterns at 1575 MHz

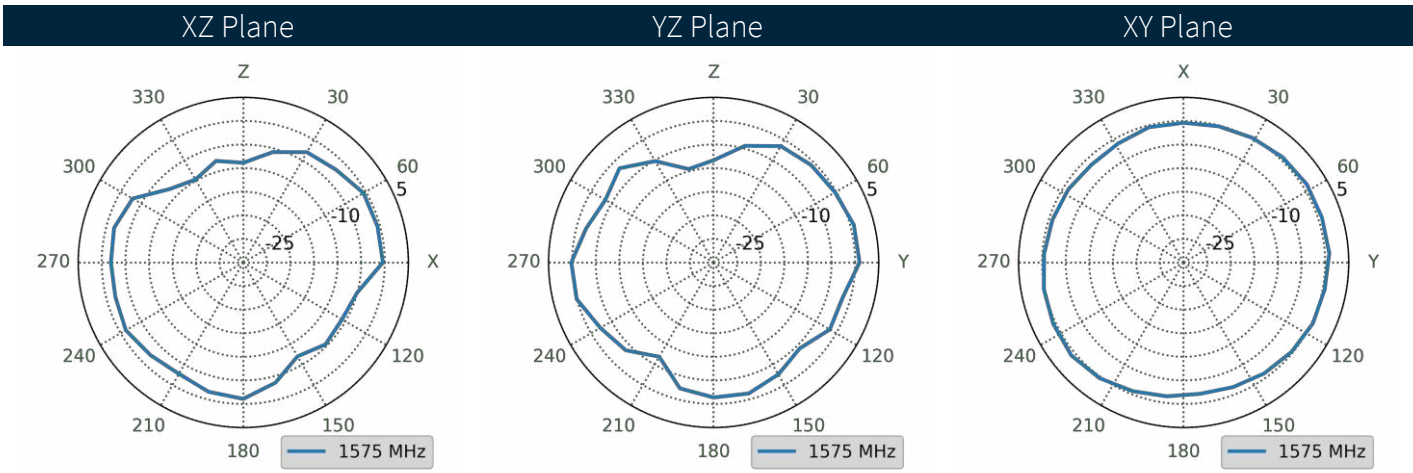
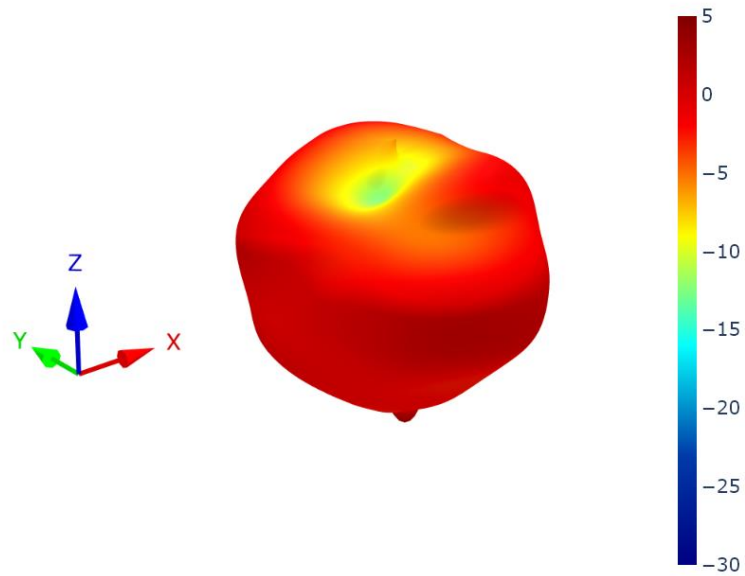

4.3 AGGBP.25B.07.0060A Patterns at 1602 MHz

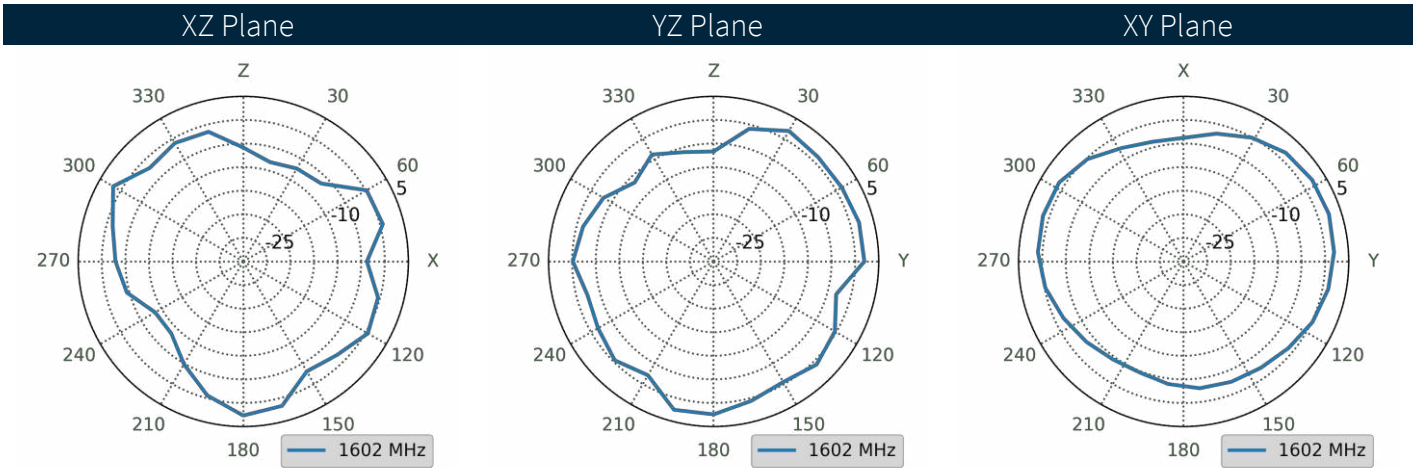
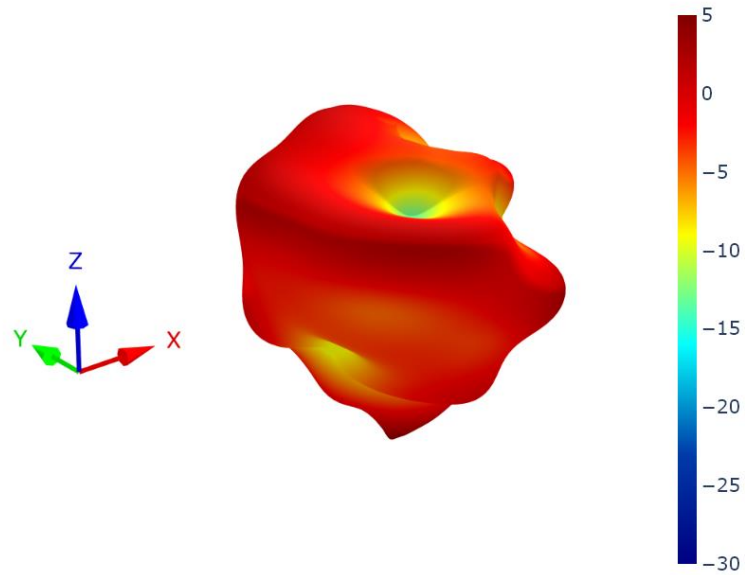

5. LNA Characteristics

5.1 LNA Gain @3.0V

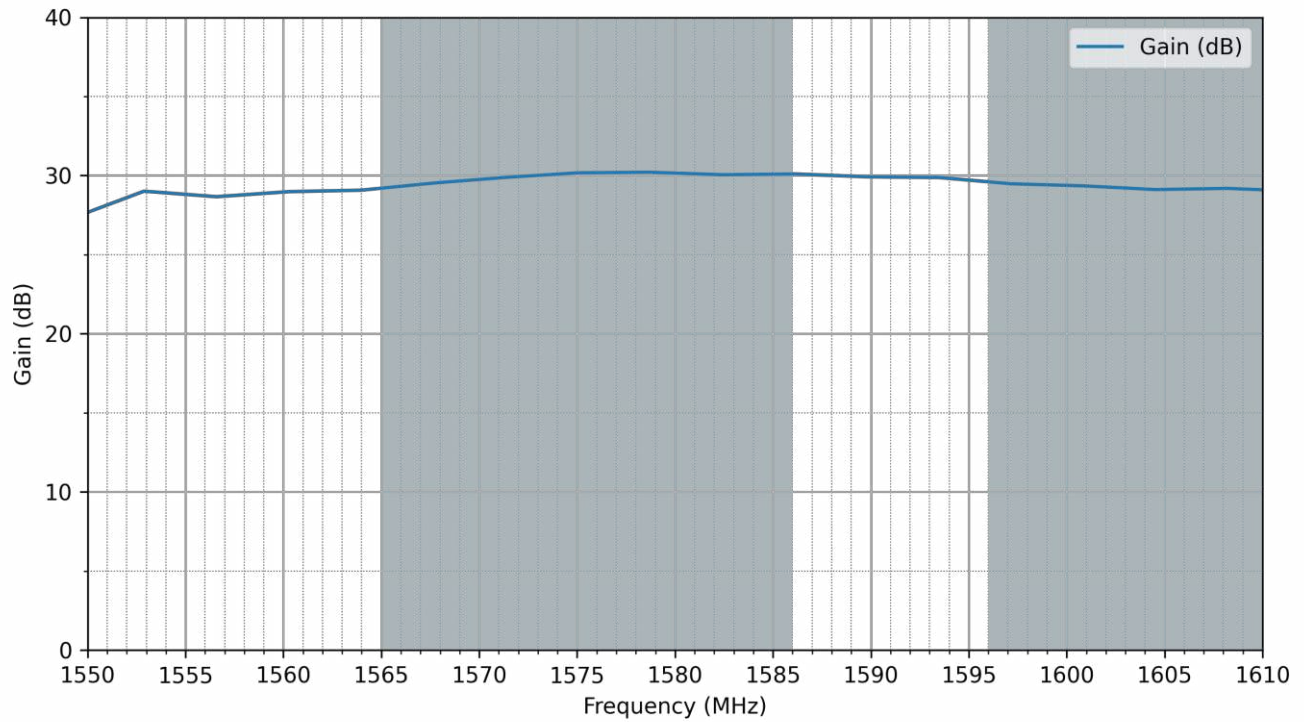

5.2 Noise Figure @3.0V

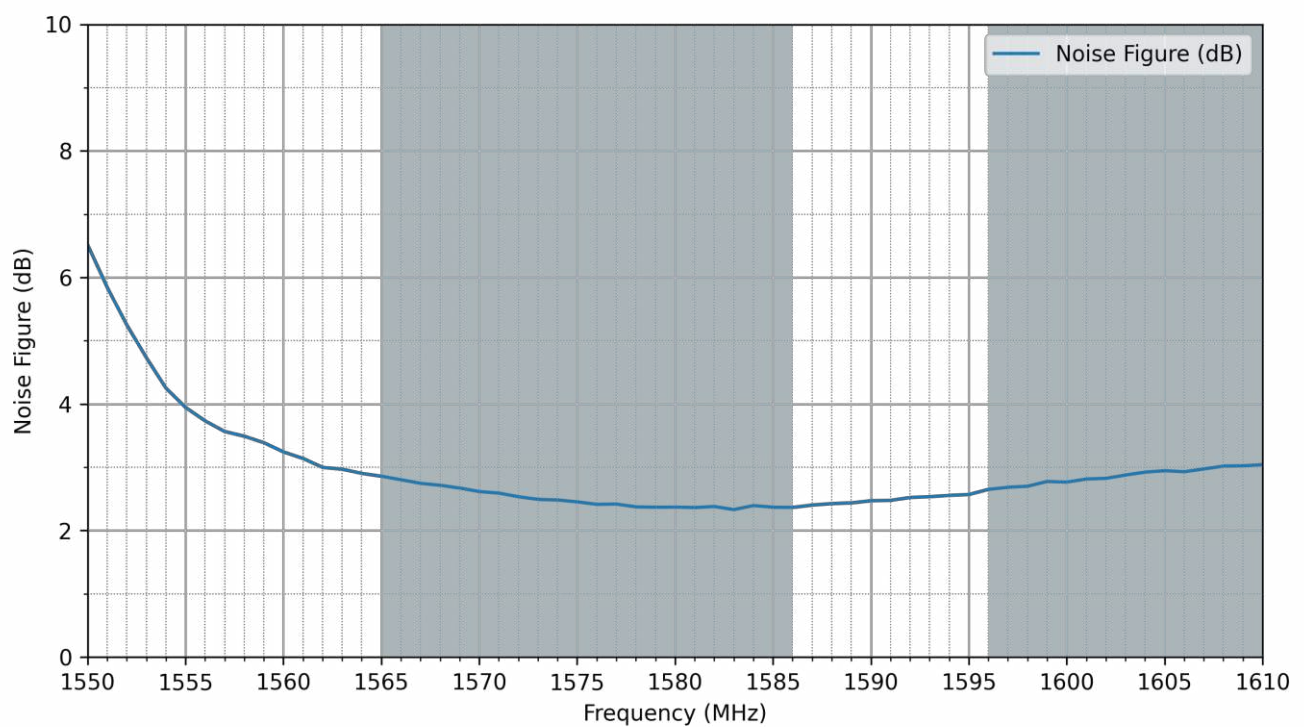

5.3 Out of Band attenuation @3.0V

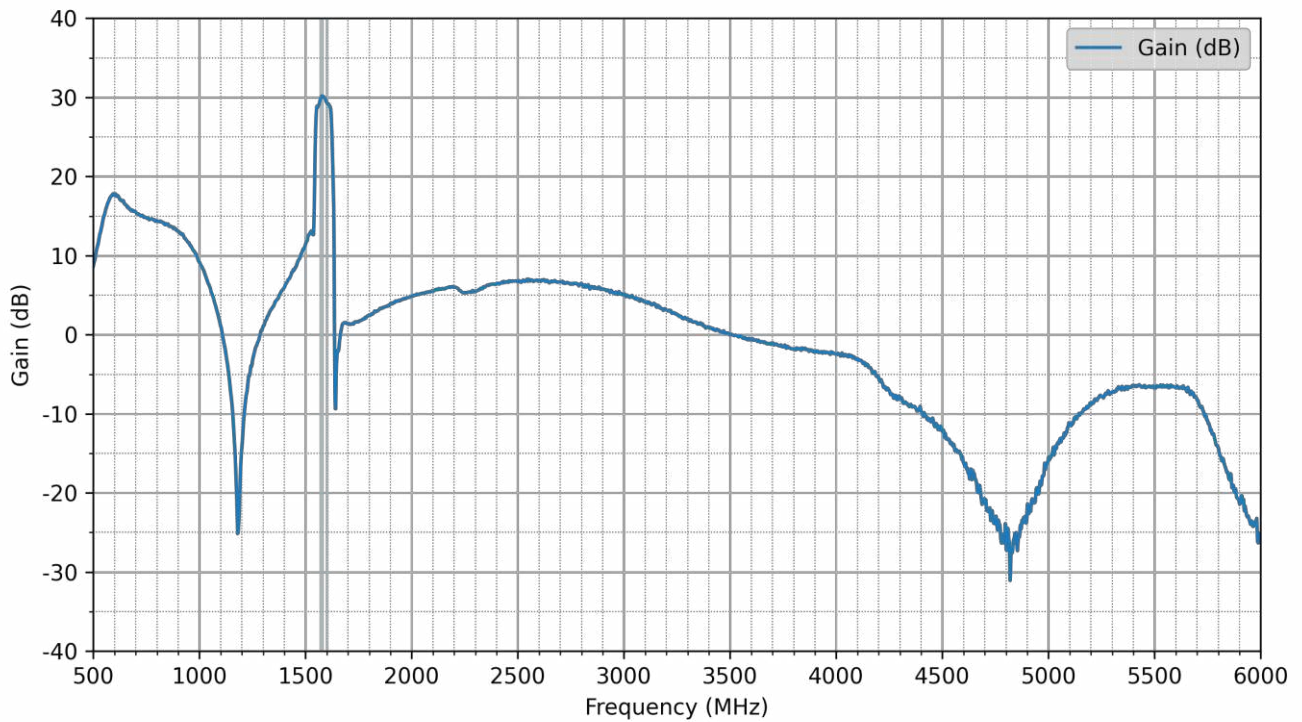

5.4 P1dB (1575.42MHz) @3.0V

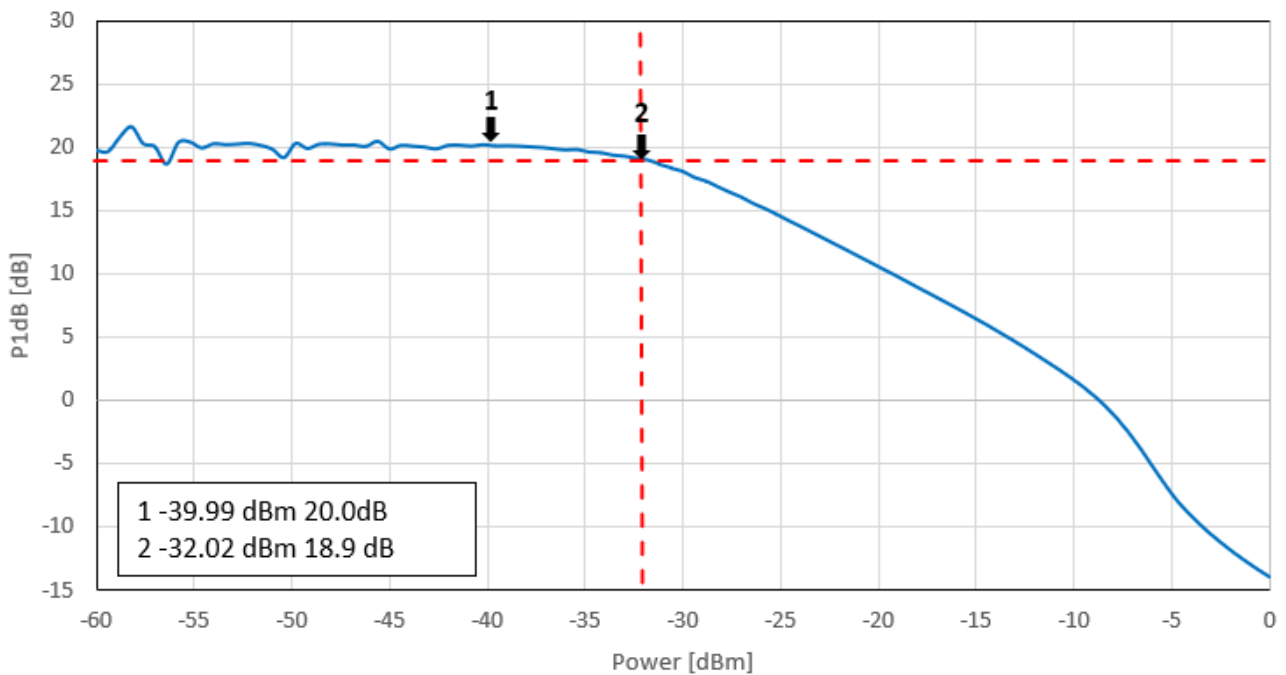

6. Mechanical Drawing

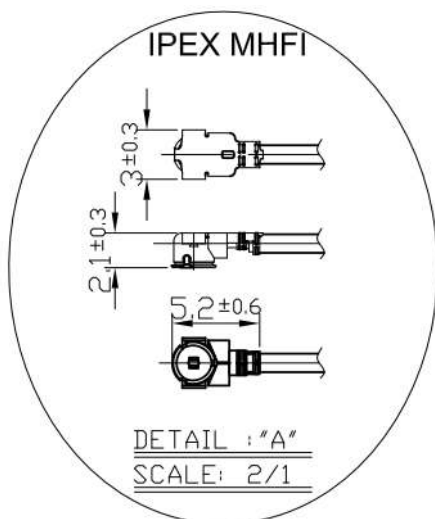
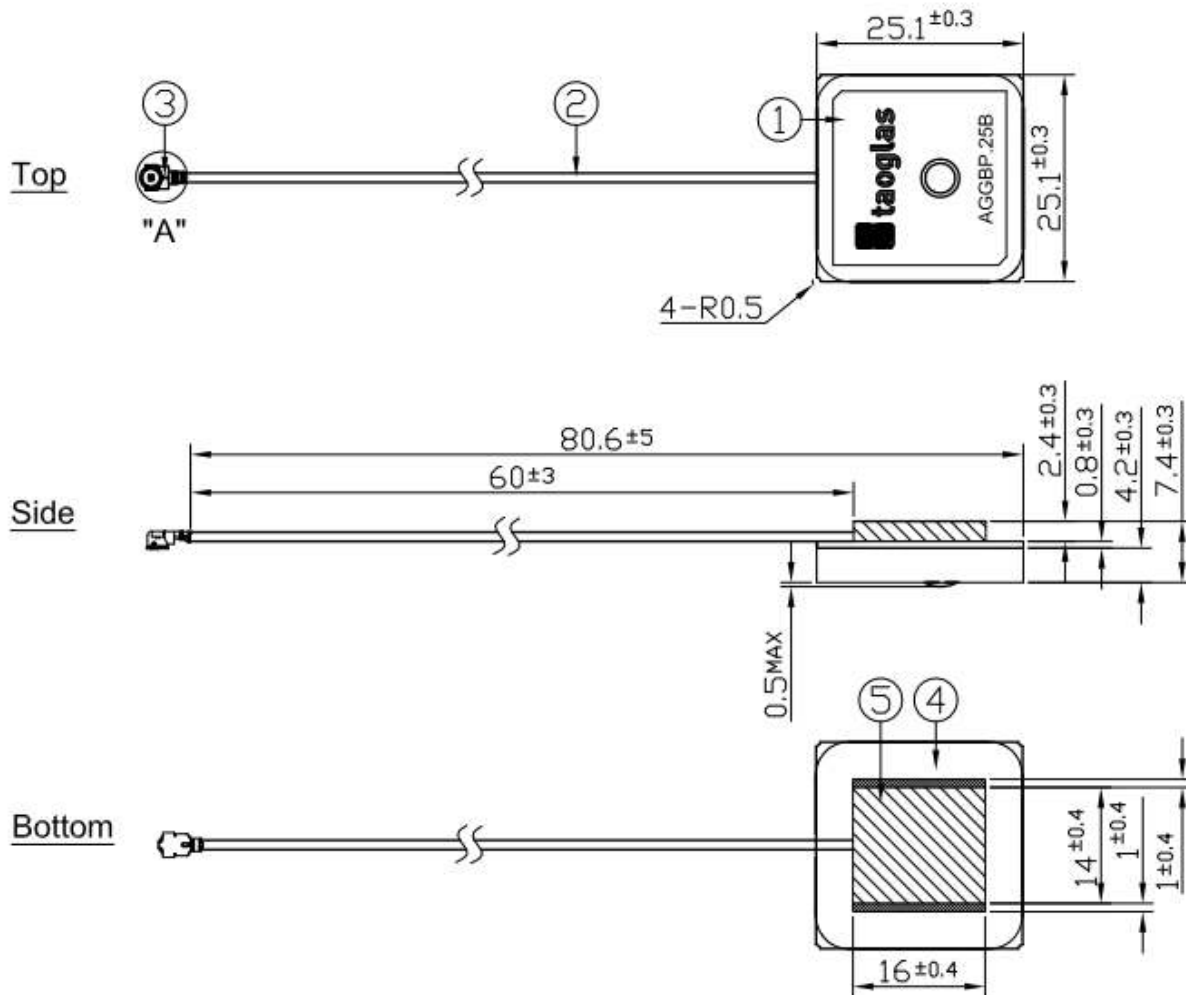

	Name	Material	Finish	QTY
1	Patch (25*25*4mm)	Ceramic	Clear	1
2	1.13 Coaxial Cable	FEP	Gray	1
3	IPEX MHF1	Brass	Gold	1
4	PCB	FR4 0.8t	Green	1
5	Shielding Case	(Tin)SPTE	Tin Plated	1

7. Packaging

Packaging Specifications

30 pcs per tray
 5 Trays per PE bag
 Tray Dimensions - 370*305*25mm
 Weight - 421g

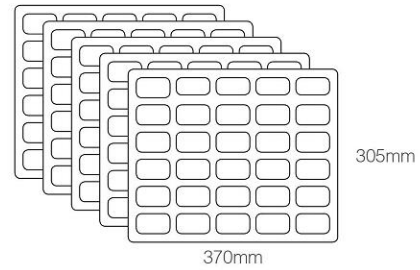

5 Trays per Carton - 150 pcs
 Carton Dimensions - 390*320*290mm

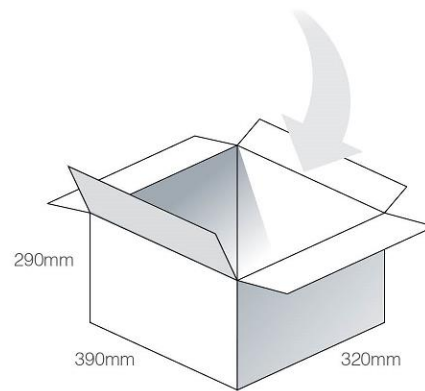

Pallet Dimensions 1100*1100*1310mm
 24 Cartons per Pallet
 4 Cartons per layer
 6 Layers

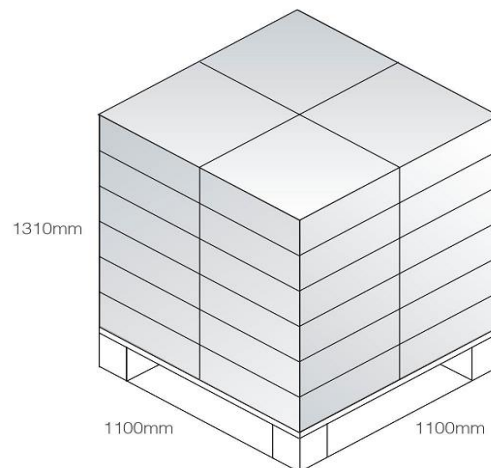

Changelog for the datasheet

SPE-15-8-022 – AGGBP.25B.07.0060A

Revision: B (Current Version)

Date:	2023-05-16
Changes:	Full datasheet update
Changes Made by:	Gary West

Previous Revisions

Revision: A (Original First Release)

Date:	2015-04-15
Notes:	
Author:	Unknown



www.taoglas.com

