

REVISIONS				
P.	LTN	DESCRIPTION	DATE	APVD
C		REVISED PER ECO-14-005095	14APR2014	AP RP
D		REVISED PER ECO-16-008845	20SEP2016	AP RP

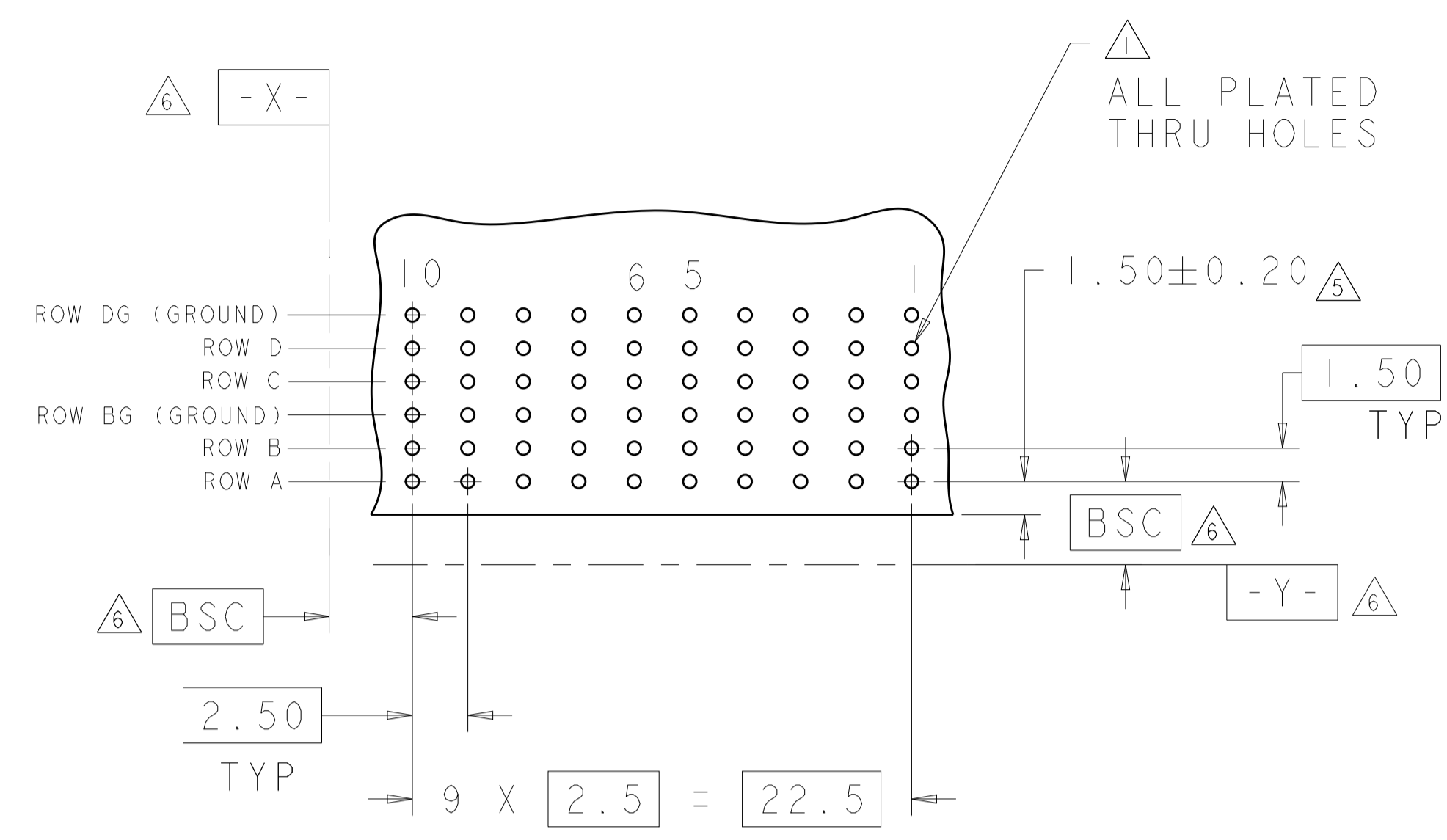

RECOMMENDED PC BOARD LAYOUT,
 DAUGHTER BOARD,
 COMPONENT SIDE SHOWN
 SCALE 4:1

- △ REFERENCE APPLICATION SPEC 114-13059 FOR RECOMMENDED PLATED THRU HOLE DIAMETER AND PLATING THICKNESSES.
- △ MATERIAL:
 SHIELD - PHOSPHOR BRONZE
 CONTACT - COPPER-NICKEL-SILICON
 HOUSING, CHICKLET AND CHICKLET COVER - GLASS FILLED POLYESTER, UL 94V-0 RATED.
- △ FINISH: CONTACT AND SHIELD
 MATING AREA - 1.27µm MIN GOLD OVER 1.27µm MIN NICKEL
 COMPLIANT PIN AREA - 0.5µm MIN MATTE TIN OVER 1.27µm MIN NICKEL
- △ CONNECTOR MARKED WITH PART NUMBER AND DATE CODE IN APPROXIMATE AREA SHOWN
- △ DIMENSION APPLIES TO CENTERLINE OF THRU HOLE.
- △ DATUMS AND BASIC DIMENSIONS ESTABLISHED BY CUSTOMER.
- △ CONTACT AREA LUBRICATED WITH BELLCORE APPROVED LUBRICANT. TECHNICAL REFERENCE: GR-1217-CORE, ISSUE 1, NOVEMBER 1995.
- △ FINISH: CONTACT AND SHIELD
 MATING AREA - 2.54µm MIN GOLD OVER 1.27µm MIN NICKEL
 COMPLIANT PIN AREA - 0.5µm MIN MATTE TIN OVER 1.27µm MIN NICKEL

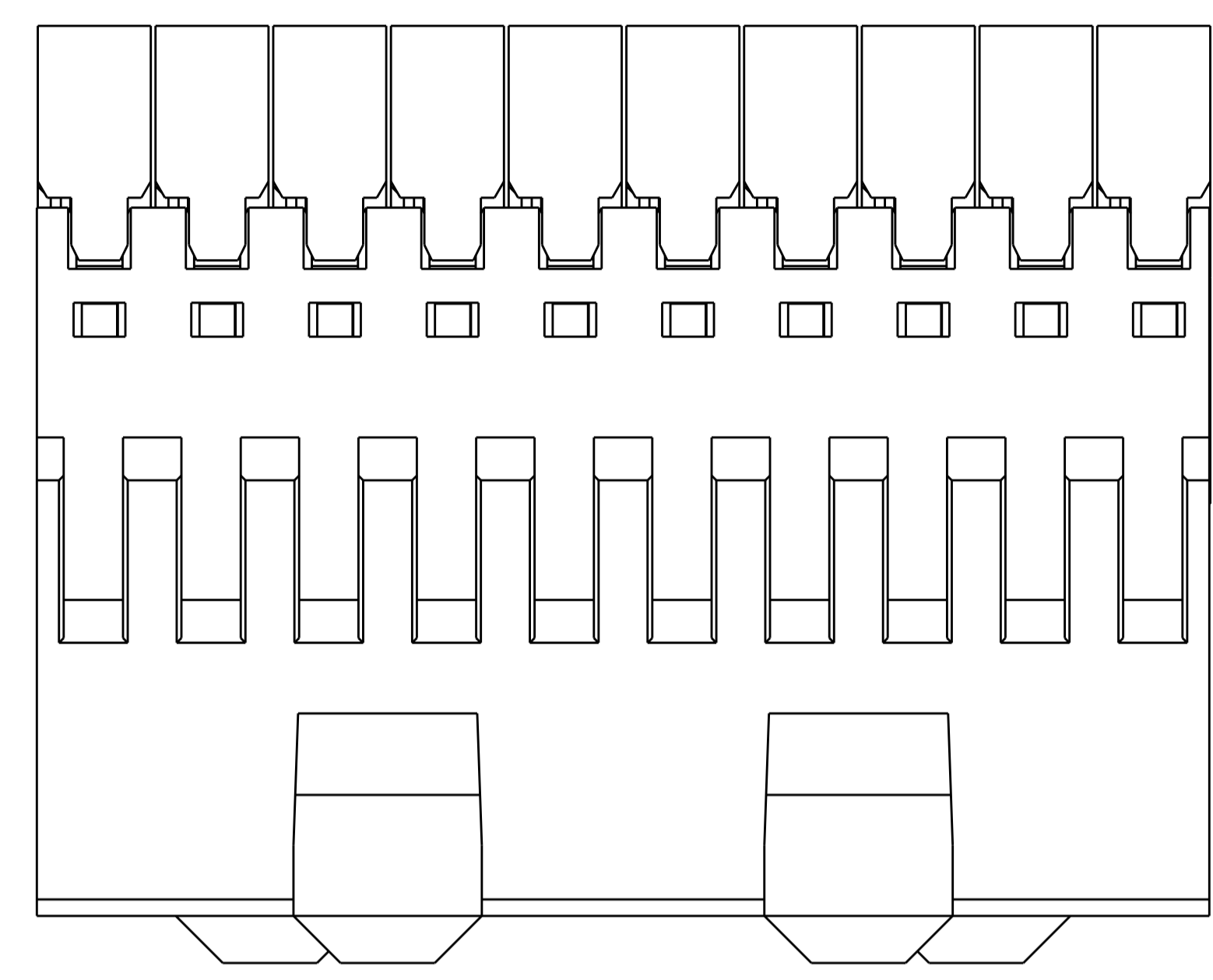
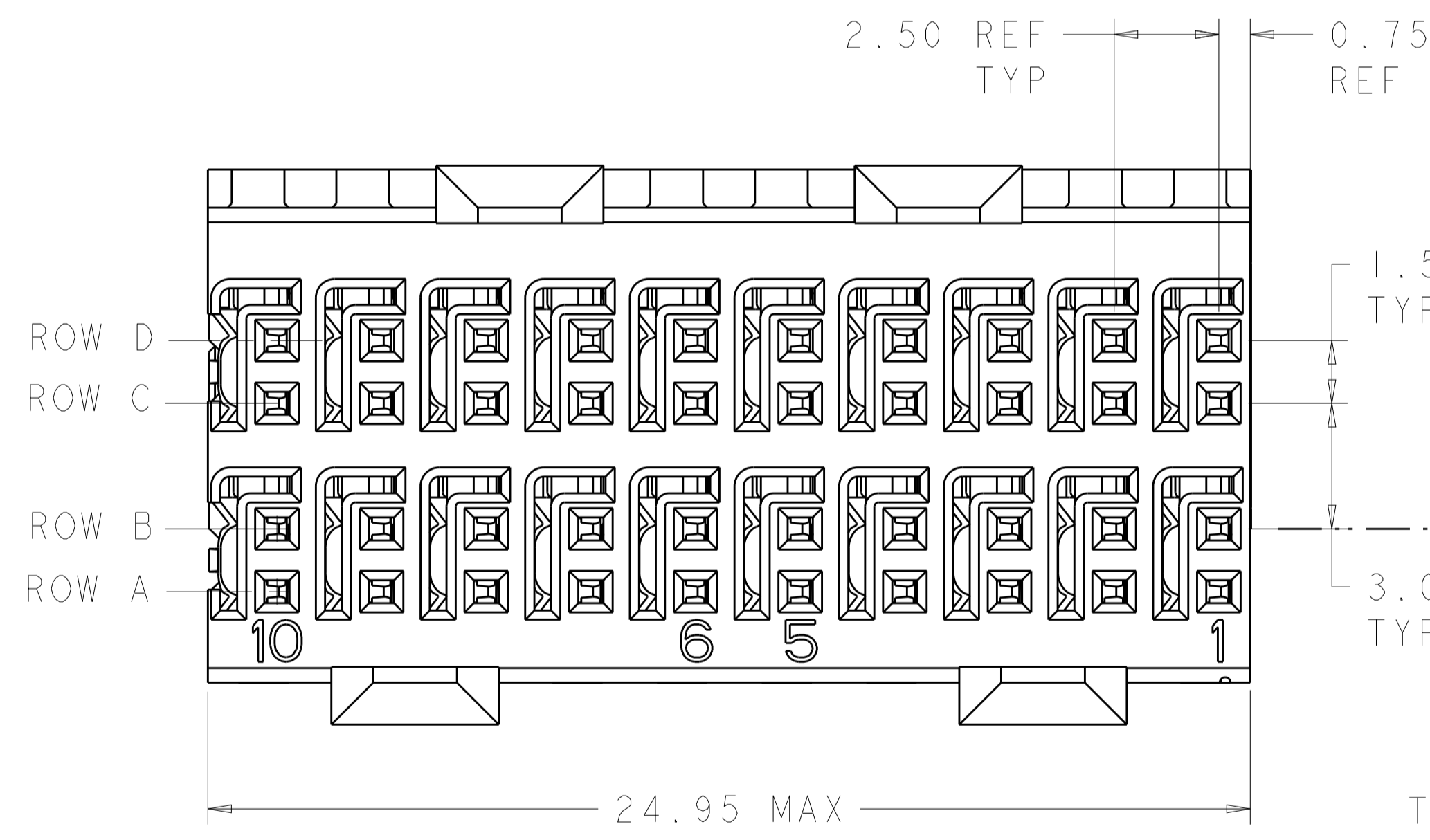

TOP SURFACE OF DAUGHTER CARD

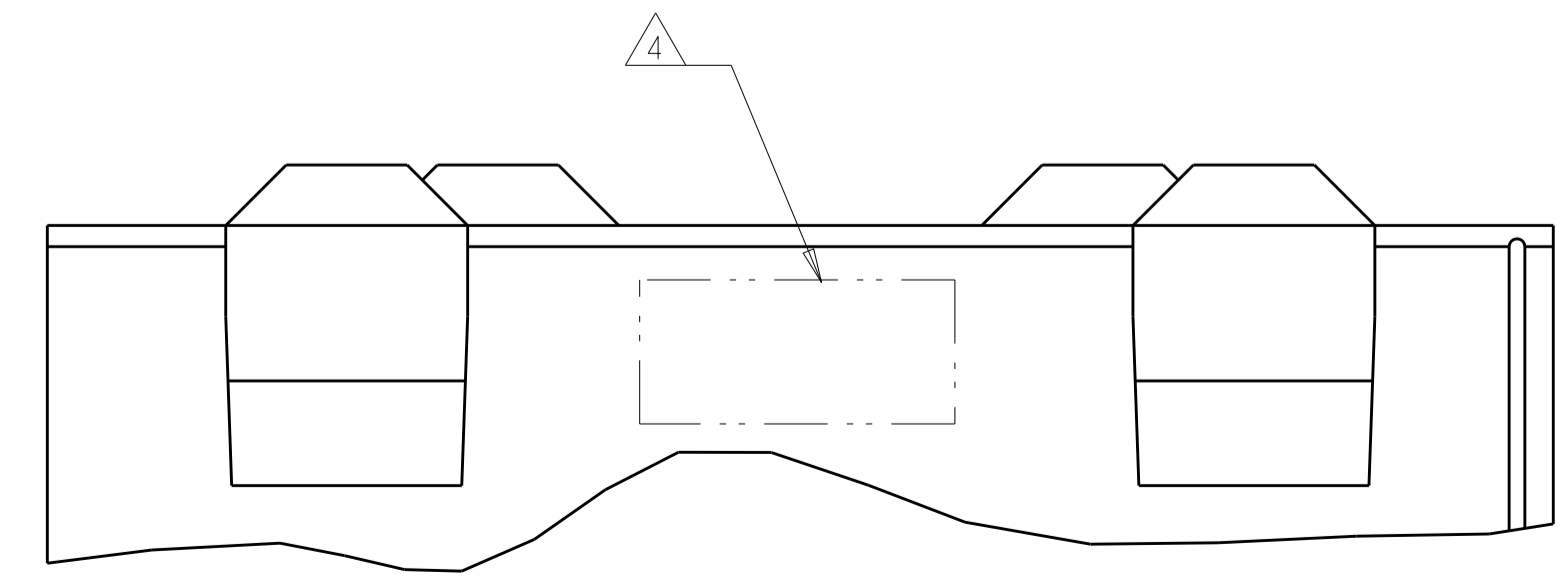
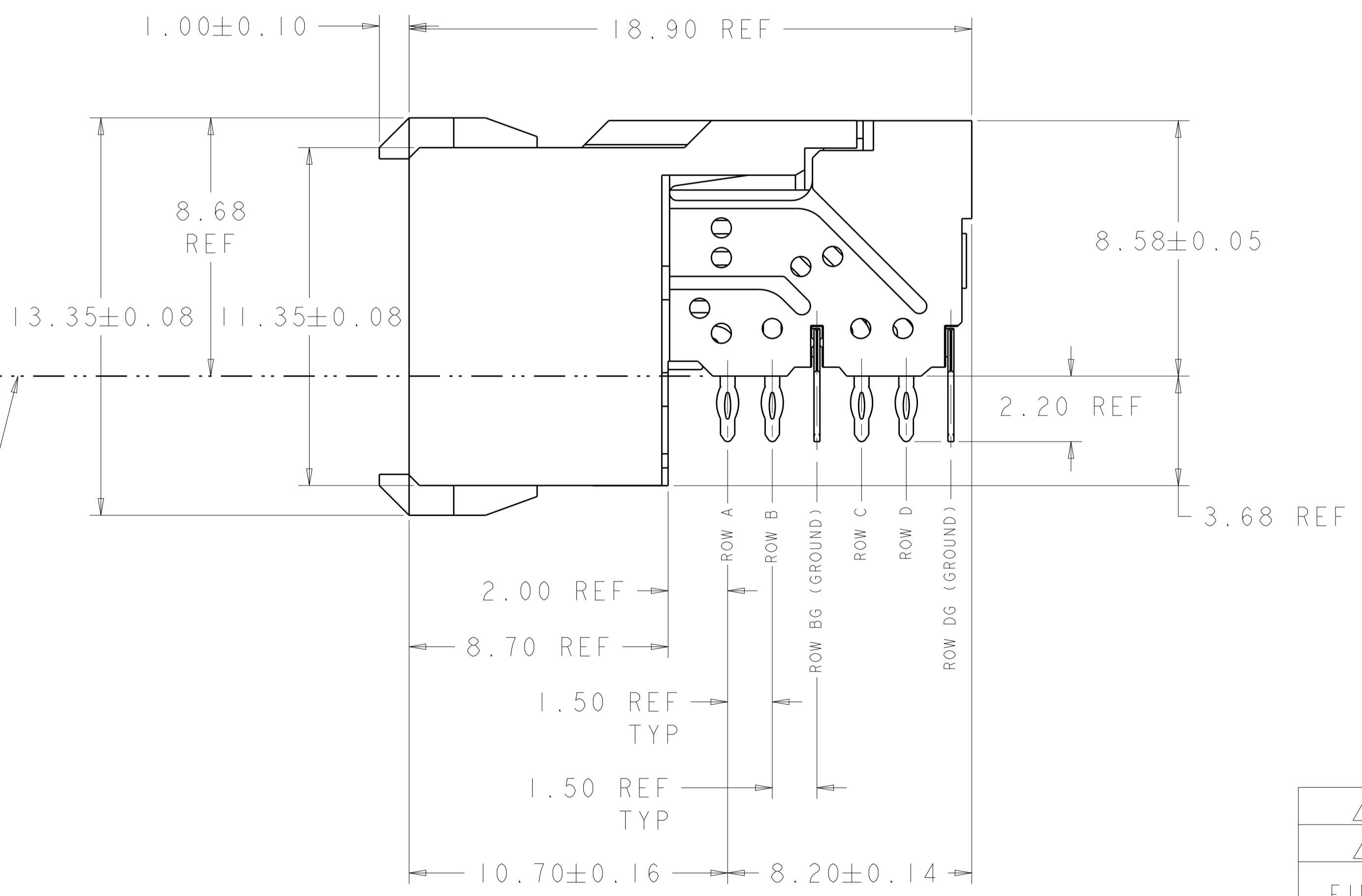

△ 8	1645599-2
△ 3	1645599-1
FINISH	PART NUMBER

THIS DRAWING IS A CONTROLLED DOCUMENT.

DIMENSIONS:	TOLERANCES UNLESS OTHERWISE SPECIFIED:	OWN: D. HUMBERT 09FEB2011	CHK: J. EARY 09FEB2011	APVD: J. EARY 09FEB2011
mm	0 PLC ± 1 PLC ± 2 PLC ± 3 PLC ± 4 PLC ± ANGLES ±	NAME: RECEPTACLE ASSEMBLY, 2 PAIR, 25mm, HMZd	SIZE: A1	CAGE CODE: 1645599
MATERIAL:	FINISH:	WEIGHT:	CUSTOMER DRAWING	SCALE: 8:1

STE TE Connectivity

RESTRICTED TO

SHEET 1 OF 1 REV D