

DA7202

10W Mono Class D amplifier for 2S battery operated portable devices

DA7202 is a powerful, highly efficient, low EMI, standalone high performance mono Class-D speaker driver designed to drive 10W into 4Ω loads directly from a 2S lithium-ion battery pack.

DA7202 targets a variety of two cell portable applications such as Ultrabooks™ and tablets.

DA7202 uses a fully-differential switched mode amplifier architecture with a fixed +18 dB gain and differential analogue inputs. It also has a PWM modulator and an H bridged switched power output stage that delivers 3.8 W_{rms} into an 8 Ω load (10.2W into a 4 Ω load), making a speaker sound louder in portable devices.

DA7202 can be directly connected between the two-cell battery and the speaker. Noise suppression circuitry to reduce audible pops and clicks at the speaker is also included.

DA7202 is available in 9 bump WL-CSP package, 0.5mm pitch, enabling low cost PCB technology, ideal for portable applications requiring small footprints.

Block Diagram

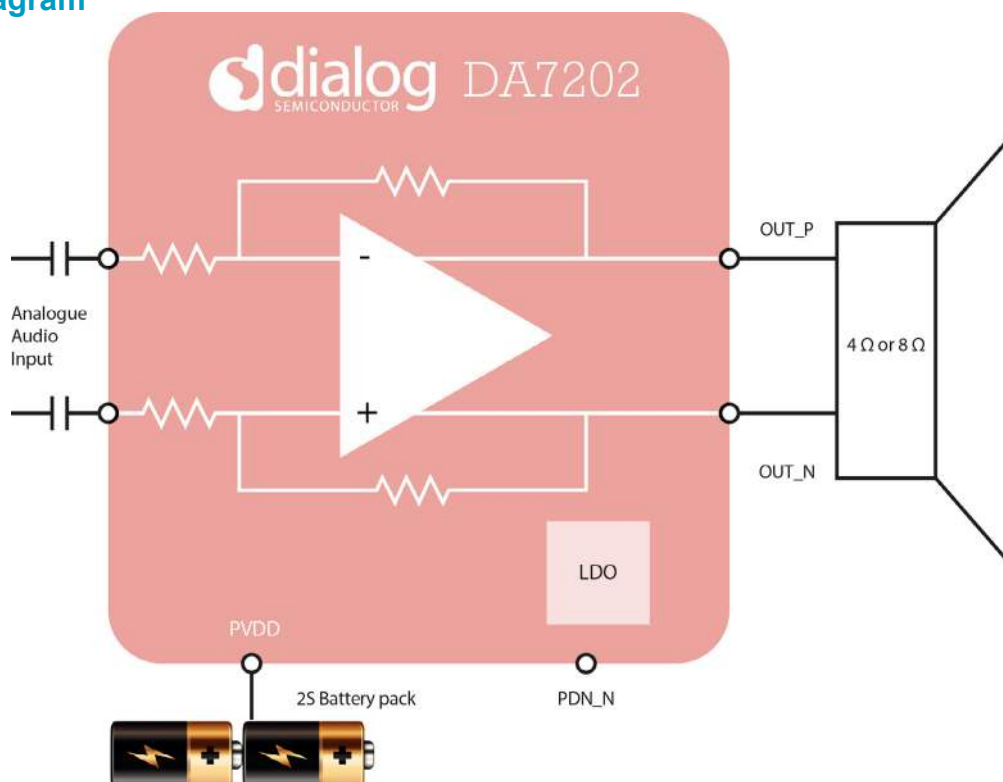

Features

- ▶ Low Component Count
- ▶ Small PCB area due to 9 bump WLCSP 0.5mm pitch package
- ▶ Good PSRR and THD+N
- ▶ Differential Audio inputs
- ▶ Low EMI
- ▶ Short circuit and thermal overload protection with auto recovery

Applications

- ▶ UltrabooksTM
- ▶ Tablets
- ▶ Personal Navigation Devices
- ▶ Speaker Accessories
- ▶ Handheld Gaming
- ▶ Mobile Computing

Functions

- ▶ Supports 4Ω and 8Ω loads
- ▶ Input supply range: 4.5 to 9.0V
- ▶ Prms : 9.0W into 4Ω load @ 8.2V, 1% THD+N
- ▶ Prms : 10.2W into 4Ω load @ 8.2V, 10% THD+N
- ▶ Prms : 3.8W into 8Ω load @ 8.2V, 1% THD+N
- ▶ Prms : 5.0W into 8Ω load @ 8.2V, 10% THD+N
- ▶ Efficiency: 85% @ Pout = 7.0W @ 8.2V, 4Ω
- ▶ Efficiency: 90% @ Pout = 3.5W @ 8.2V, 8Ω
- ▶ Ultra-low standby current : 7μA
- ▶ SNR (A-weighted) 104dB
- ▶ THD+N: 90dB
- ▶ PSRR: 78dB
- ▶ Fixed +18db gain



THD+N vs Output Power for different battery configurations

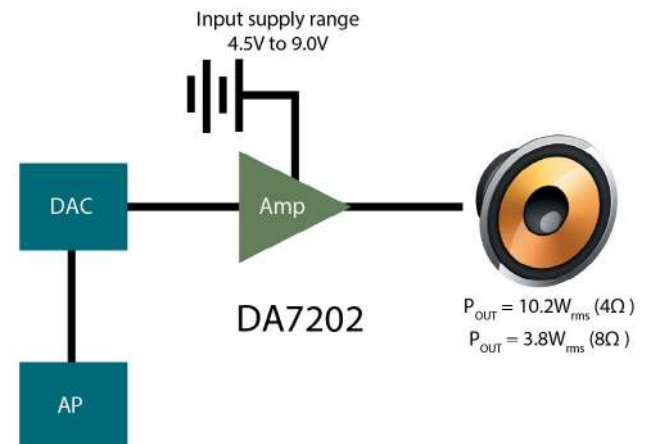

Audio system diagram

Dialog Semiconductor Worldwide Sales Offices - www.dialog-semiconductor.com

email: info@diasemi.com

United Kingdom
Phone: +44 1793 757700

The Netherlands
Phone: +31 73 640 88 22

Japan
Phone: +81 3 5425 4567

Singapore
Phone: +65 648 499 29

Korea
Phone: +82 2 3469 8200

Germany
Phone: +49 7021 805-0

North America
Phone: +1 408 845 8500

Taiwan
Phone: +886 281 786 222

Hong Kong
Phone: +852 3769 5200

China (Shenzhen)
Phone: +86 755 2981 3669

China (Shanghai)
Phone: +86 21 5424 9058

This publication provides outline information only, which unless agreed by Dialog Semiconductor may not be used, applied or reproduced for any purpose, or be regarded as a representation relating to products. Please refer to Dialog standard supply terms on the company website (www.dialog-semiconductor.com).

© Dialog Semiconductor 2015. All rights reserved. 0415XXX