

THIS DRAWING IS UNPUBLISHED. RELEASED FOR PUBLICATION 20
 © COPYRIGHT 20 BY TYCO ELECTRONICS CORPORATION. ALL RIGHTS RESERVED.

LOC	DIST	REVISIONS			
P	LTR	DESCRIPTION	DATE	DWN	APVD
E	B	F	ECR-06-023739	27JUL2006	MJG JA
		G	ECR-08-031520	11/12/08	MJG JA

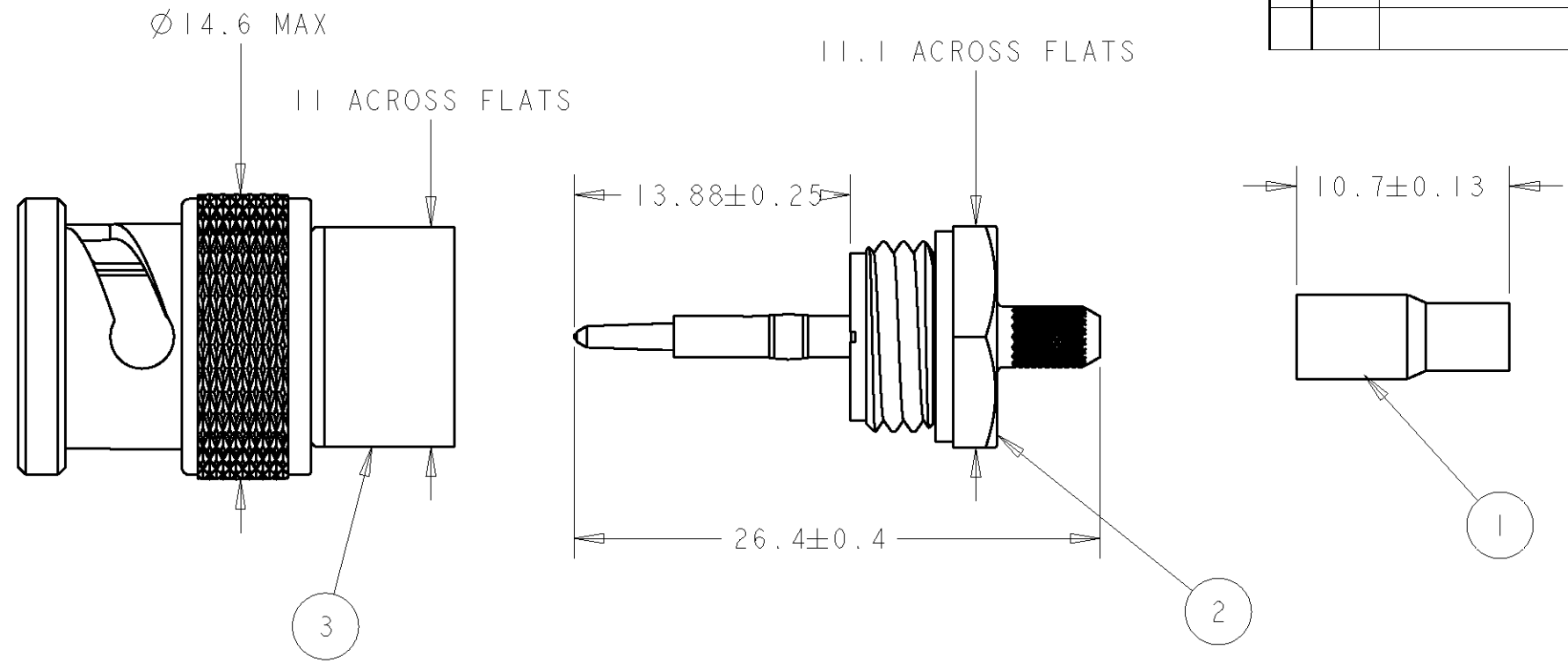

RECOMMENDED CABLE PREPARATION
 DENUDAGE RECOMMANDE

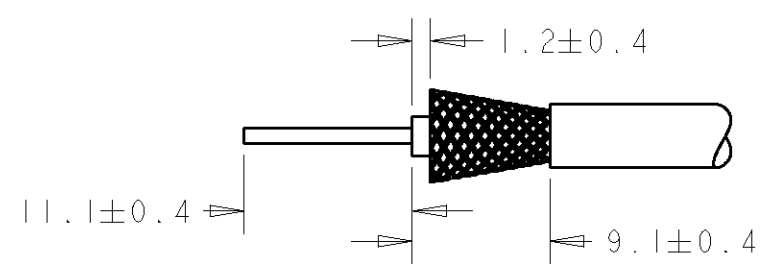

NOTES:

- FOR USE WITH RG-188 KX22 KX3 CABLE
 UTILISER AVEC CABLE RG-188 KX22 KX3
- CRIMP WITH HAND TOOL Pt No 476408 OR 69710-1 + INSET 476410
 PINCE A SERTIR REF: 476408 ou 69710-1 + MATRICE 476410
- INSTRUCTION SHEET 408-1799-1
 INSTRUCTION DE SERTISSAGE: 408-1799-1

131036	BNC PLUG ASSY	330949	3
	JACK CRIMP END	131044-2	2
	FERRULE	328666	1
ASSY NO	DESCRIPTION	PART NO	ITEM

<small>THIS DRAWING IS A CONTROLLED DOCUMENT FOR TYCO ELECTRONICS CORPORATION IT IS SUBJECT TO CHANGE AND THE CONTROLLING ENGINEERING ORGANIZATION SHOULD BE CONTACTED FOR THE LATEST REVISION.</small>		DWN M GREENER 27JUL2006 CHK J AMBROSE 27JUL2006 APVD J AMBROSE 27JUL2006		Tyco Electronics Tyco Electronics Bideford Devon EX31 2NY	
DIMENSIONS: mm		TOLERANCES UNLESS OTHERWISE SPECIFIED: 0 PLC ±- 1 PLC ±0.3 2 PLC ±0.3 3 PLC ±0.3 4 PLC ± ANGLES ±1		NAME BNC SERIES STRAIGHT PLUG SINGLE CRIMP	
MATERIAL -		FINISH -		PRODUCT SPEC 108-12002 APPLICATION SPEC -	
WEIGHT -		SIZE A300779		CAGE CODE C-131036	
CUSTOMER DRAWING		SCALE 2:1		SHEET 1 OF 1 REV G	