

SPECIFICATIONS

PARAMETERS	VALUES	UNIT
RATED VOLTAGE	3.6	V0-pk
OPERATING VOLTAGE RANGE	3 ~ 4.5	V0-pk
RATED CURRENT (MAX)	100	mA
COIL RESISTANCE	18 ± 5	OHM
MINIMUM SPL @ 10 CM	90	dB
RESONANT FREQUENCY	2830 ± 500	Hz
OPERATING TEMPERATURE	-20 ~ +70	°C
STORAGE TEMPERATURE	-40 ~ +85	°C
HOUSING MATERIAL	LCP (BLACK)	-
TERMINAL MATERIAL	GOLD PLATED BRASS	-
WEIGHT	0.8	grams

THIS DOCUMENT CONTAINS DATA PROPRIETARY TO PROJECTS UNLIMITED, INC. ANY USE OR REPRODUCTION, IN ANY FORM, WITHOUT PRIOR WRITTEN PERMISSION OF PROJECTS UNLIMITED, INC. IS PROHIBITED.
©2003, Projects Unlimited Inc.

REVISION HISTORY

LTR	DESCRIPTION	DATE	APPROVED
-	RELEASED FROM ENGINEERING	12/18/2014	
A	CORRECTION TO POLARITY	10/10/2019	M.L.
B	REVISED VOLTAGE UNITS AND RANGE	3/2/2020	M.V.

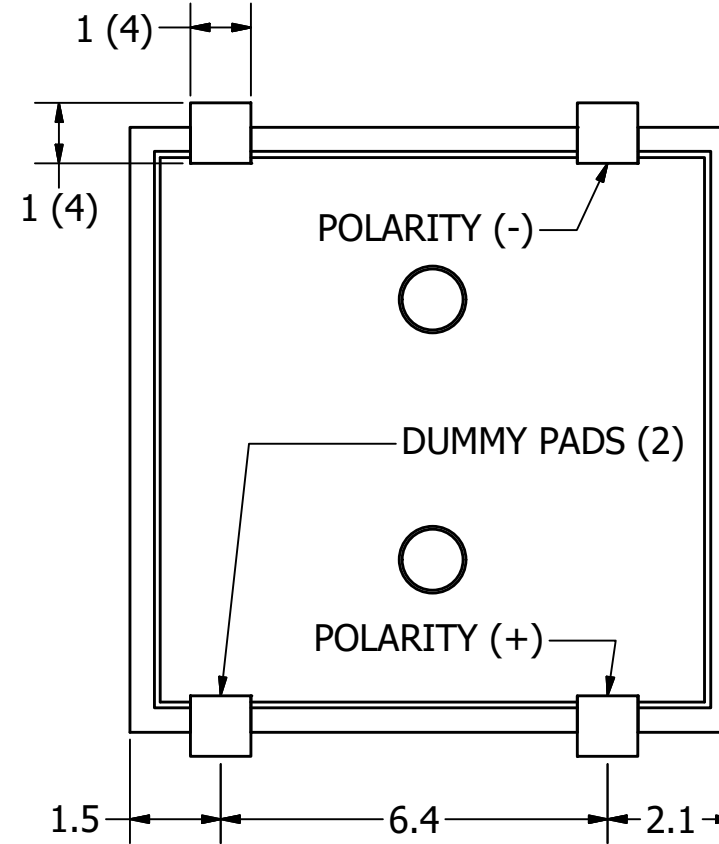
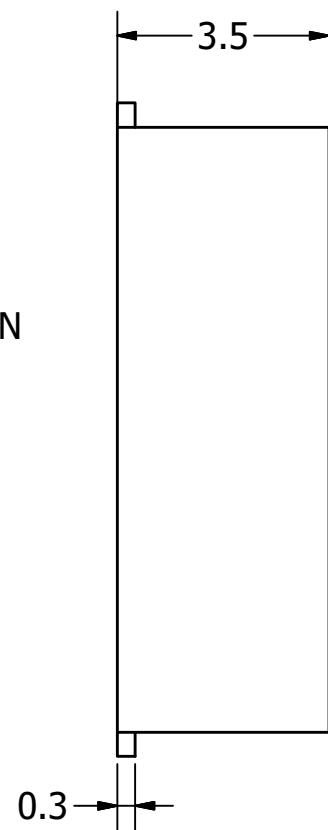
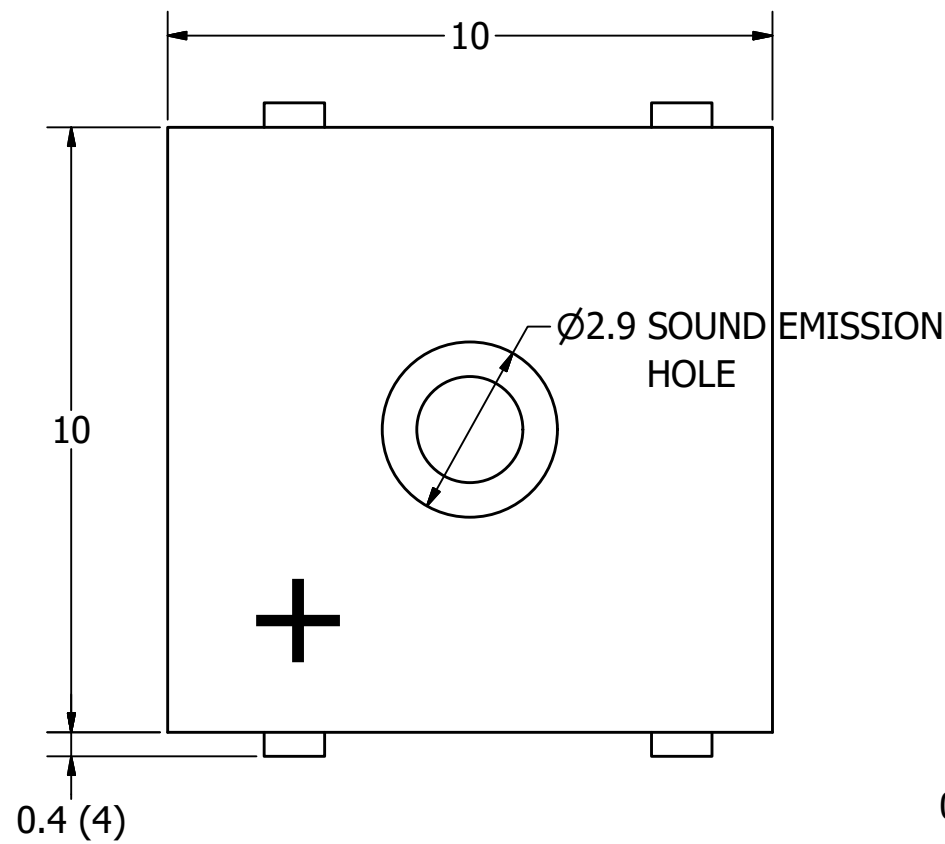
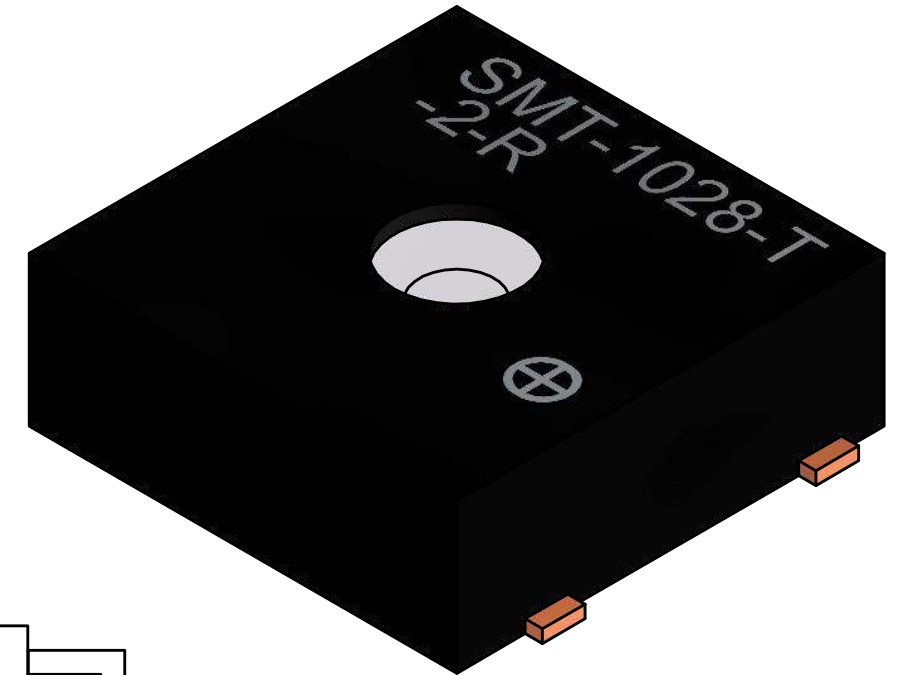

NOTES:

1. ALL DIMENSIONS ARE IN MILLIMETERS.
2. SPECIFICATIONS SUBJECT TO CHANGE OR WITHDRAWL WITHOUT NOTICE.
3. THIS PART IS RoHS 2011/65/EU COMPLIANT.

UNLESS OTHERWISE SPECIFIED:
ALL PURCHASES ARE SUBJECT TO AND INCORPORATE THE PUI AUDIO TERMS AND CONDITIONS SALE FOUND AT http://www.puiaudio.com/pdf/terms_conditions.pdf (paper copy available upon request).
DIMENSIONS ARE IN MILLIMETERS, TOLERANCES ARE ±0.5 AND ANGLES ARE ±3°.

SIZE
A3

Designed by	Date	Checked by	Date	Approved by	Date	Drawn Date
T.E.S.	12/18/2014	C.W.	12/18/2014	B.R.	12/18/2014	12/18/2014



SMT-1028-T-2-R

Transducer (Electro-Mech) Edition - Sheet 1 / 1

SMT-1028-T-2-R.idw