

REVISIONS				
REV.	ECO. NO	DESCRIPTION	DATE	BY
A	1750	INITIAL RELEASE	7-10-08	MNH
B	3859	ADD REF CONTACT GAP DIM, INSULATOR COLOR	6/4/2018	JH

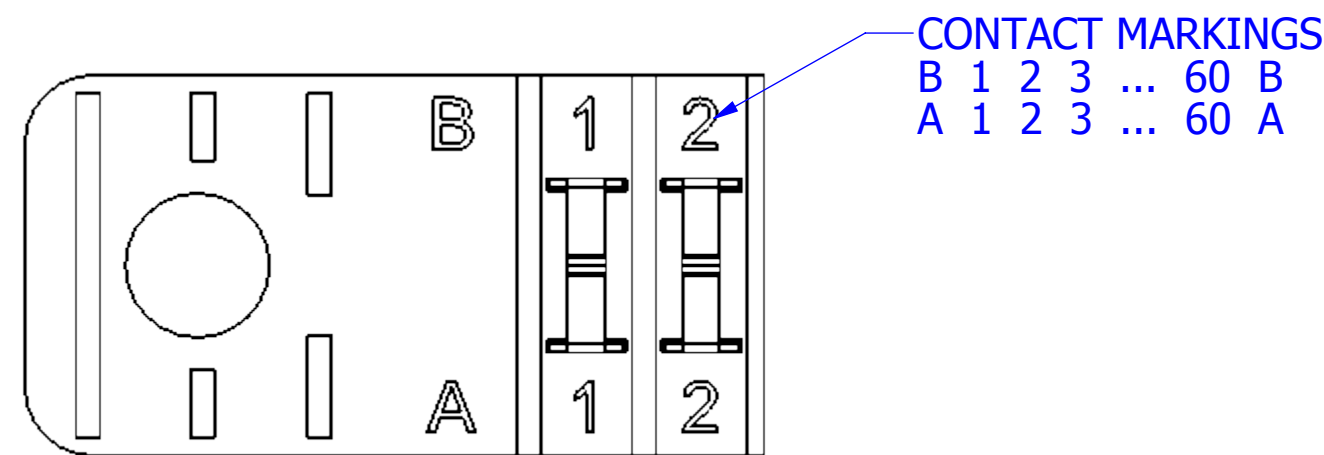
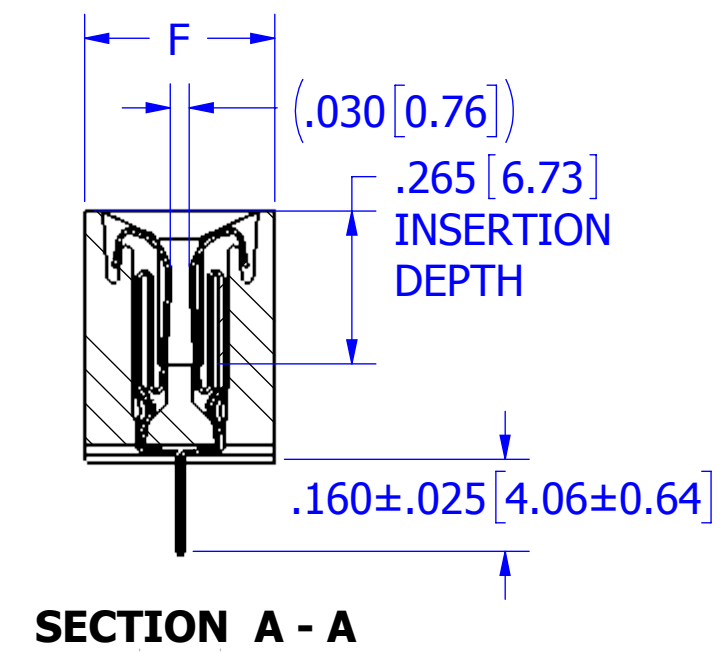
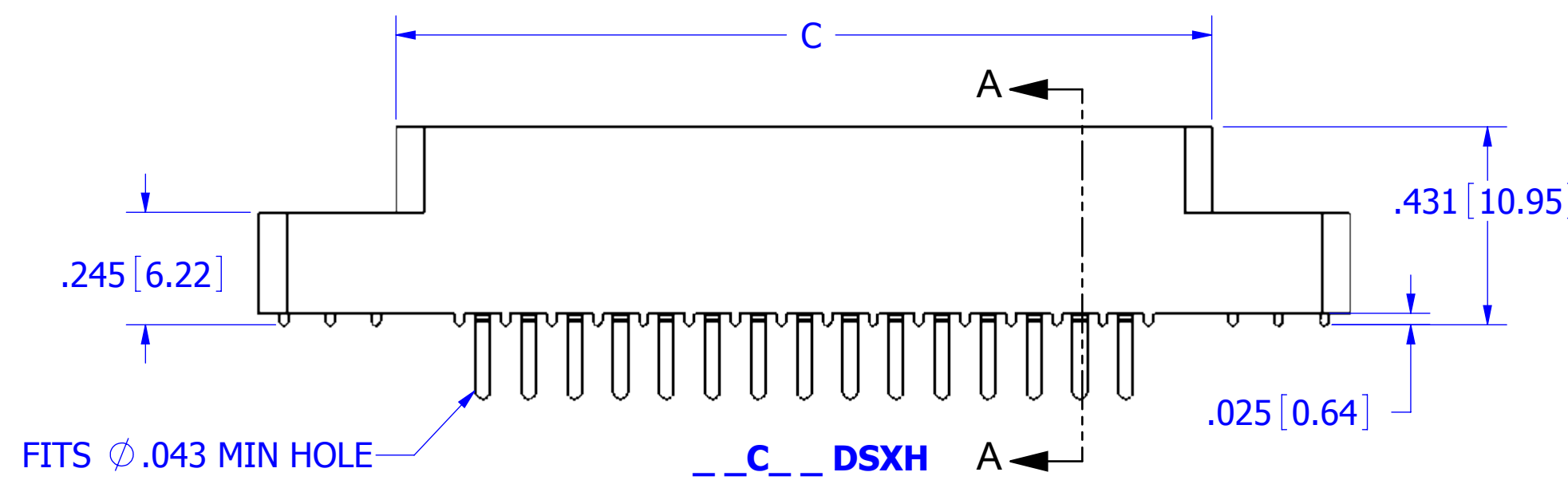
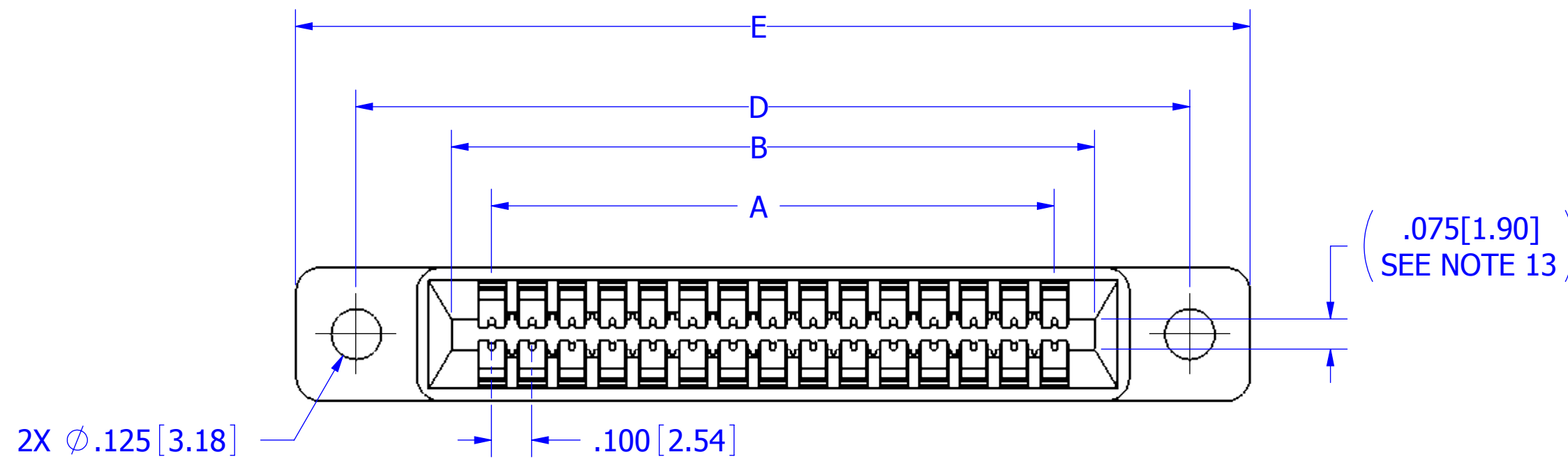

**NOTES:**

- INSULATOR MATERIAL: SEE PART NUMBER CODING
- CONTACT MATERIAL: SEE PART NUMBER CODING
- PLATING: SEE PART NUMBER CODING
- OPERATING TEMPERATURE: SEE PART NUMBER CODING
- PROCESSING TEMP: SEE PART NUMBER CODING
- UL FLAMMABILITY RATING: 94V-0
- OPERATING VOLTAGE: 700 VAC
- CURRENT RATING: 3 AMP
- CONTACT RESISTANCE: 30 MILLI OHMS MAX
- INSULATION RESISTANCE: 5000 MEGA OHMS
- DURABILITY: 500 CYCLES MINIMUM
- CONNECTOR IDENTIFICATION: THE PART SHALL BE MARKED WITH A PART NUMBER AND LOT CODE
- BOARD THICKNESS ACCOMMODATED:  $.062 \pm .008 [1.57 \pm 0.20]$
- INSERTION FORCE: 16 OZ MAX PER CONTACT PAIR WHEN USING A  $.062 [1.57]$  TEST BLADE  
INTERNAL INSPECTION TO BE PER SULLINS WORK INSTRUCTION WI-8.6-03
- WITHDRAWAL FORCE: 1 OZ MIN PER CONTACT PAIR USING  $.062 [1.57]$  TEST BLADE

**CONTACT ID  
SCALE 6:1**



UNLESS OTHERWISE SPECIFIED: DIMENSIONS ARE IN INCHES [MM]		DRAWN	DATE	NAME	
			7/10/2018	MNH	
TOLERANCES: ANGULAR: $\pm 1^\circ$ DECIMALS .XX = $\pm .02 [ .5]$ .XXX = $\pm .005 [ .13]$ .XXXX = $\pm .0005 [ .013]$					TITLE <b>CONNECTOR, .100 CC LP</b>
THE INFORMATION HEREIN CONTAINS PROPRIETARY INFORMATION OF SULLINS ELECTRONICS AND IS NOT TO BE REPRODUCED, USED OR DISCLOSED TO OTHERS FOR ANY PURPOSE EXCEPT AS SPECIFICALLY AUTHORIZED IN WRITING BY AN OFFICER OF SULLINS ELECTRONICS.					PART NUMBER <b>__C__DSX__</b>
SIZE	CAGE CODE	DWG. NO.	REV		
<b>C</b>	<b>54453</b>	<b>C11127</b>	<b>B</b>		
SCALE: 3:1		SHEET 1 OF 3			

**CUSTOMER COPY**

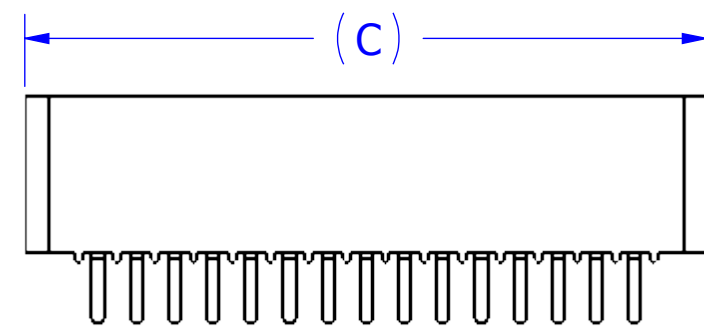
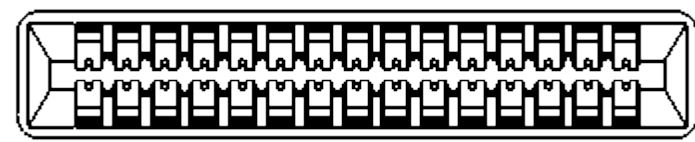

**\_\_C\_\_DSXN**

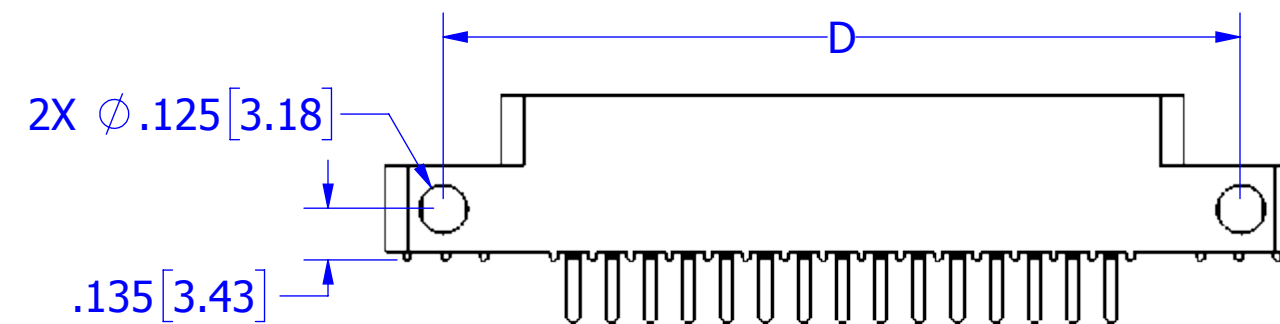

**\_\_C\_\_DSXS**

2X #4-40 THREADED  
INSERTS

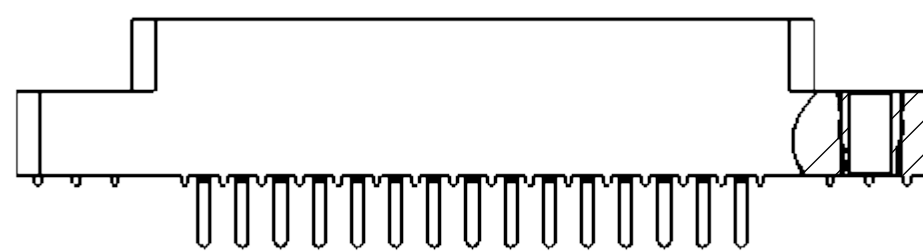
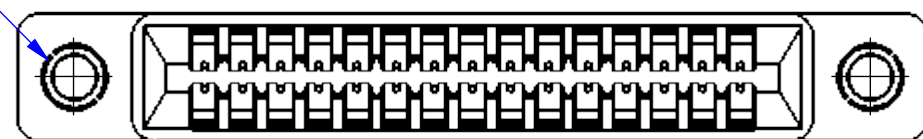

**\_\_C\_\_DSXI**

2X FLOATING BOBBIN  
Ø .116 [2.95] CLEARANCE  
FOR # 4 SCREW

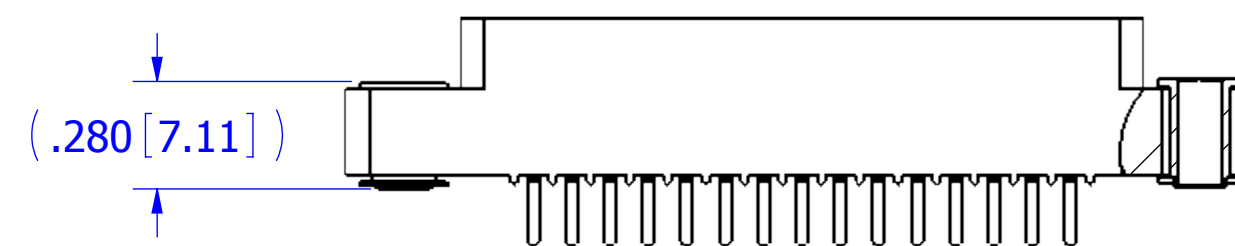

**\_\_C\_\_DSXF**

# CUSTOMER COPY



UNLESS OTHERWISE SPECIFIED:  
DIMENSIONS ARE IN INCHES [MM]

TOLERANCES:

ANGULAR: ± 1°

DECIMALS

.XX=± .02 [.5]

.XXX=± .005 [.13]

.XXXX=± .0005 [.013]

DRAWN DATE NAME  
7/10/2018 MNH

THE INFORMATION HEREIN CONTAINS  
PROPRIETARY INFORMATION OF  
SULLINS ELECTRONICS AND IS NOT  
TO BE REPRODUCED, USED OR  
DISCLOSED TO OTHERS FOR ANY  
PURPOSE EXCEPT AS SPECIFICALLY  
AUTHORIZED IN WRITING BY AN  
OFFICER OF SULLINS ELECTRONICS.

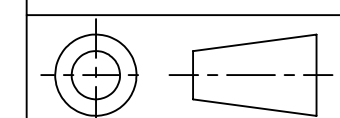

TITLE  
CONNECTOR, .100 CC LP

PART NUMBER  
\_\_C\_\_DSX\_\_

SIZE C	CAGE CODE 54453	DWG. NO. C11127	REV B
-----------	--------------------	--------------------	----------

SCALE: 2:1 SHEET 2 OF 3



PART NUMBER	NO. OF POS.	A ±.008[0.20]		B ±.008[0.20]		C ±.015[0.38]		D ±.010[0.25]		E ±.020[0.51]		F+.005/- .015[+0.13/-0.38]	
		IN	MM	IN	MM	IN	MM	IN	MM	IN	MM	IN	MM
C04DSX	4	0.300	7.62	0.500	12.70	0.675	17.15	0.975	24.77	1.275	32.39	0.330	8.38
C05DSX	5	0.400	10.16	0.600	15.24	0.775	19.69	1.075	27.31	1.375	34.93		
C06DSX	6	0.500	12.70	0.700	17.78	0.875	22.23	1.175	29.85	1.475	37.47		
C07DSX	7	0.600	15.24	0.800	20.32	0.975	24.77	1.275	32.39	1.575	40.01		
C08DSX	8	0.700	17.78	0.900	22.86	1.075	27.31	1.375	34.93	1.675	42.55		
C10DSX	10	0.900	22.86	1.100	27.94	1.275	32.39	1.575	40.01	1.875	47.63		
C12DSX	12	1.100	27.94	1.300	33.02	1.475	37.47	1.775	45.09	2.075	52.71		
C13DSX	13	1.200	30.48	1.400	35.56	1.575	40.01	1.875	47.63	2.175	55.25		
C15DSX	15	1.400	35.56	1.600	40.64	1.775	45.09	2.075	52.71	2.375	60.33		
C17DSX	17	1.600	40.64	1.800	45.72	1.975	50.17	2.275	57.79	2.575	65.41		
C18DSX	18	1.700	43.18	1.900	48.26	2.075	52.71	2.375	60.33	2.675	67.95		
C19DSX	19	1.800	45.72	2.000	50.80	2.175	55.25	2.475	62.87	2.775	70.49		
C20DSX	20	1.900	48.26	2.100	53.34	2.275	57.79	2.575	65.41	2.875	73.03		
C22DSX	22	2.100	53.34	2.300	58.42	2.475	62.87	2.775	70.49	3.075	78.11		
C23DSX	23	2.200	55.88	2.400	60.96	2.575	65.41	2.875	73.03	3.175	80.65		
C25DSX	25	2.400	60.96	2.600	66.04	2.775	70.49	3.075	78.11	3.375	85.73		
C26DSX	26	2.500	63.50	2.700	68.58	2.875	73.03	3.175	80.65	3.475	88.27		
C28DSX	28	2.700	68.58	2.900	73.66	3.075	78.11	3.375	85.73	3.675	93.35		
C30DSX	30	2.900	73.66	3.100	78.74	3.275	83.19	3.575	90.81	3.875	98.43		
C31DSX	31	3.000	76.20	3.200	81.28	3.375	85.73	3.675	93.35	3.975	100.97		
C35DSX	35	3.400	86.36	3.600	91.44	3.775	95.89	4.075	103.51	4.375	111.13		
C36DSX	36	3.500	88.90	3.700	93.98	3.875	98.43	4.175	106.05	4.475	113.67		
C40DSX	40	3.900	99.06	4.100	104.14	4.275	108.59	4.575	116.21	4.875	123.83		
C43DSX	43	4.200	106.68	4.400	111.76	4.575	116.21	4.875	123.83	5.175	131.45		
C44DSX	44	4.300	109.22	4.500	114.30	4.675	118.75	4.975	126.37	5.275	133.99		
C49DSX	49	4.800	121.92	5.000	127.00	5.175	131.45	5.475	139.07	5.775	146.69		
C50DSX	50	4.900	124.46	5.100	129.54	5.275	133.99	5.575	141.61	5.875	149.23		
C52DSX	52	5.100	129.54	5.300	134.62	5.475	139.07	5.775	146.69	6.075	154.31		
C60DSX	60	5.900	149.86	6.100	154.94	6.275	159.39	6.575	167.01	6.875	174.63		
C65DSX	65	6.400	162.56	6.600	167.64	6.775	172.09	7.075	179.71	7.375	187.33		

**PART NUMBER CODING**

**MATERIAL (INSULATOR/CONTACT)**

- E = BLUE PBT/PHOSPHOR BRONZE**  
OPERATING TEMP: -65°C TO +125°C  
PROCESSING TEMP: WAVE/MANUAL SOLDERING ONLY
- R = GREEN PPS/PHOSPHOR BRONZE**  
OPERATING TEMP: -65°C TO +125°C  
PROCESSING TEMP: 260°C MAX FOR 20 SECS
- G = BLACK PA9T/PHOSPHOR BRONZE**  
OPERATING TEMP: -65°C TO +125°C  
PROCESSING TEMP: 260°C MAX FOR 20 SECS
- H = BLUE PBT/BERYLLIUM COPPER**  
OPERATING TEMP: -65°C TO +125°C  
PROCESSING TEMP: WAVE/MANUAL SOLDERING ONLY
- A = GREEN PPS/BERYLLIUM COPPER**  
OPERATING TEMP: -65°C TO +150°C  
PROCESSING TEMP: 260°C MAX FOR 20 SECS
- J = BLACK PA9T/BERYLLIUM COPPER**  
OPERATING TEMP: -65°C TO +150°C  
PROCESSING TEMP: 260°C MAX FOR 20 SECS
- F = GREEN PPS/SPINODAL (CONSULT FACTORY)**  
OPERATING TEMP: -65°C TO +200°C  
PROCESSING TEMP: 260°C MAX FOR 20 SECS  
AVAILABLE IN OVERALL GOLD ONLY (S OR M PLATING CODE)  
CONSULT FACTORY FOR SPECIAL SOLDERING GUIDELINES
- C = GREEN PPS/BERYLLIUM NICKEL (CONSULT FACTORY)**  
OPERATING TEMP: -65°C TO +200°C  
PROCESSING TEMP: 260°C MAX FOR 20 SECS  
AVAILABLE IN OVERALL GOLD ONLY (S OR M PLATING CODE)
- W = TAN PEEK/BERYLLIUM NICKEL (CONSULT FACTORY)**  
OPERATING TEMP: -65°C TO +250°C  
PROCESSING TEMP: 260°C MAX FOR 20 SECS  
AVAILABLE IN OVERALL GOLD ONLY (M PLATING CODE)

**MOUNTING STYLE**

- H = .125" DIA. CLEARANCE HOLES (PAGE 1)
- I = #4-40 THREADED INSERT (PAGE 2)
- S = .125" DIA. SIDE MOUNTING (PAGE 2)
- N = NO MOUNTING EARS (PAGE 2)
- F = FLOATING BOBBIN (PAGE 2)

**NUMBER OF POSITION!  
(CONTACTS PER ROW)**

**PLATING**

- ALL PLATINGS HAVE .000050" NICKEL UNDERPLATE
- |   |                          |
|---|--------------------------|
| CONTACT SURFACE                         | TERMINATION              |
| G = .000010" GOLD                       | .000005" GOLD            |
| Y = .000030" GOLD                       | .000005" GOLD            |
| B = .000010" GOLD                       | .000100" PURE TIN, MATTE |
| C = .000030" GOLD                       | .000100" PURE TIN, MATTE |
| **E = .000100" PURE TIN, MATTE, OVERALL |                          |
| S = .000010" GOLD OVERALL               |                          |
| M = .000030" GOLD                       | .000010" GOLD OVERALL    |
- \*\* OVERALL TIN ONLY AVAILABLE ON MATERIAL CODES E, R AND G

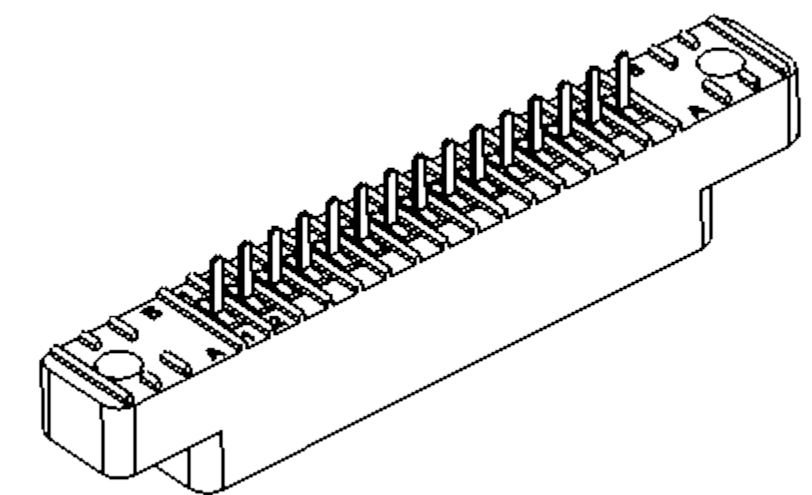

**CUSTOMER COPY**



UNLESS OTHERWISE SPECIFIED: DIMENSIONS ARE IN INCHES [MM]	DRAWN	DATE	NAME	
		7/10/2018	MNH	
TOLERANCES:  ANGULAR: ± 1°  DECIMALS .XX = ± .02 [.5] .XXX = ± .005 [.13] .XXXX = ± .0005 [.013]	<small>THE INFORMATION HEREIN CONTAINS PROPRIETARY INFORMATION OF SULLINS ELECTRONICS AND IS NOT TO BE REPRODUCED, USED OR DISCLOSED TO OTHERS FOR ANY PURPOSE EXCEPT AS SPECIFICALLY AUTHORIZED IN WRITING BY AN OFFICER OF SULLINS ELECTRONICS.</small>			<b>TITLE</b> CONNECTOR, .100 CC LP
	<b>PART NUMBER</b> _C_DSX_			<b>REV</b> B
<b>SIZE</b> C	<b>CAGE CODE</b> 54453	<b>DWG. NO.</b> C11127	<b>SCALE</b> 2:1	<b>SHEET 3 OF 3</b>