

REV A HD10-9-96P*-B009

REVISIONS			
SYM	DESCRIPTION	DATE	APPROVED
NC	NEW RELEASE PER E.O. P17374	8/02/01	R.D.R.
A	REVISED PER E.O. P20769	1-25-11	RDR

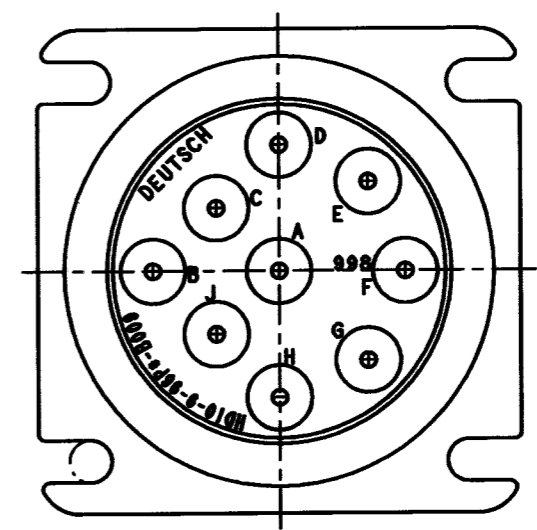

Ø.125±.015 4PL [3.18±.38] (PHANTOM LINE FOR CLARIFICATION ONLY)

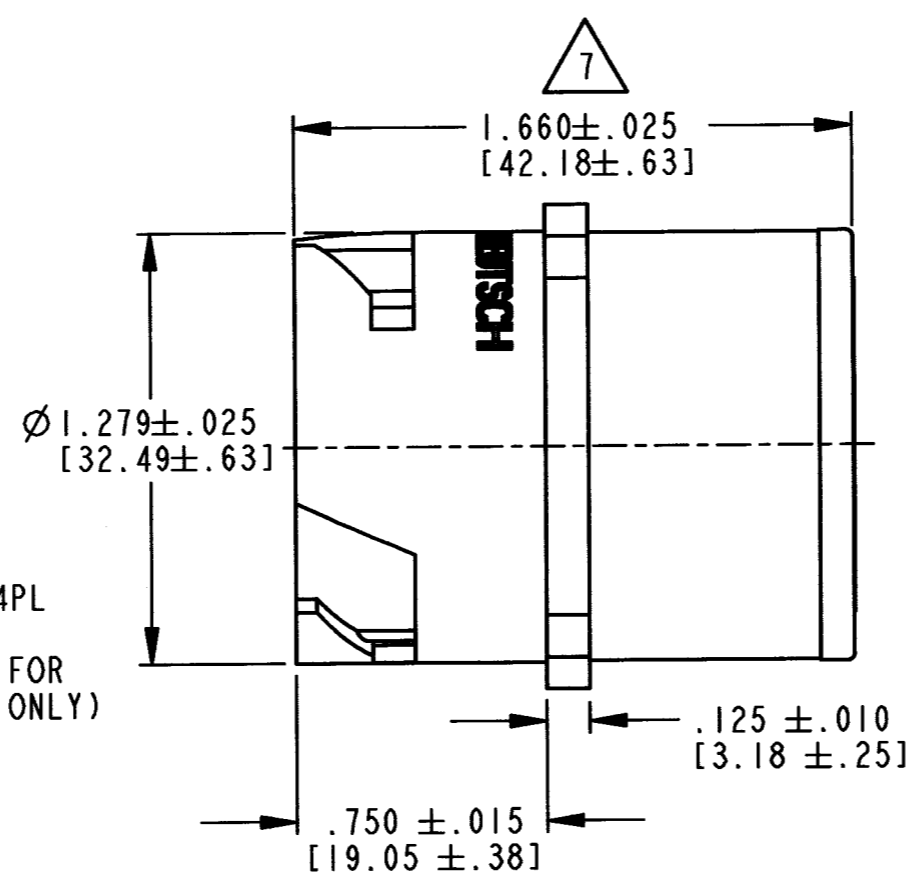
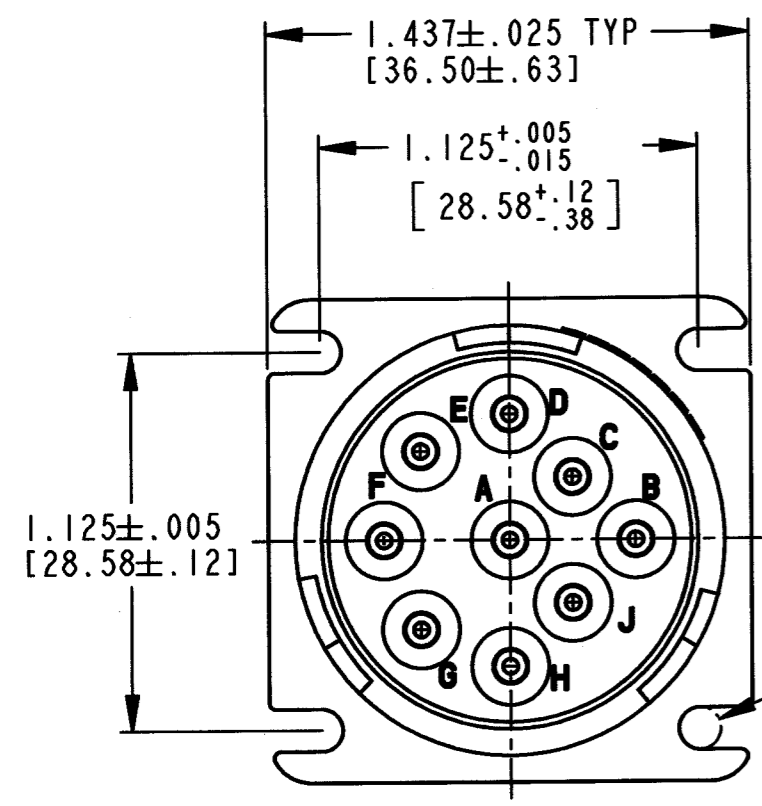
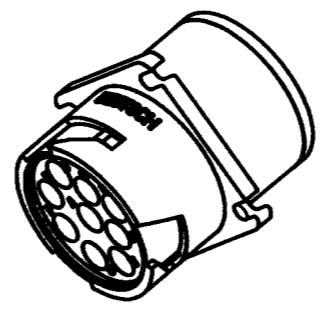

3-D VIEW

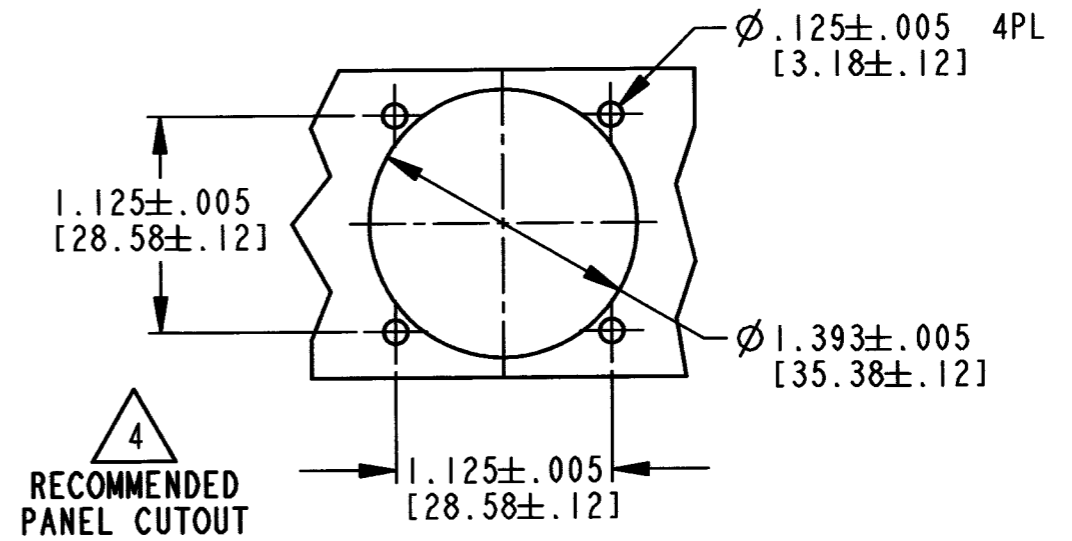

RECOMMENDED PANEL CUTOUT

- 9. MATERIAL: SHELL: PLASTIC, SEAL: RUBBER.
- 8. WHEN * = E: IDENTIFIES 'E' WIRE SEAL.
WHEN * = BLANK: IDENTIFIES 'NORMAL' WIRE SEAL.
- 7. OVERALL DIMENSION DOES NOT INCLUDE RUBBER GROMMET.
- 6. THIS RECEPTACLE MATES WITH HD16-9-96S*-**** PLUG (*=SEAL TYPE, ****= ALL MODIFICATIONS).
- 5. FOR "PERFORMANCE AND APPLICATION CHARACTERISTICS OF SOLID/STAMPED AND FORMED CONTACTS AND WIRES" SEE ENVELOPE DRAWING 0425-015-0000 THIS RECEPTACLE USES PIN CONTACTS ONLY.
- 4. MAXIMUM PANEL THICKNESS IS .250 [6.35].
- 3. ALL DIMENSIONS ARE IN INCHES [MILLIMETERS].
- 2. THIS CONNECTOR SERIES WILL ACCOMMODATE THE FOLLOWING WIRE INSULATION DIAMETERS:

SEAL TYPE	CONTACT SIZE	MIN. INSUL. O.D.	MAX. INSUL. O.D.	WIRE RANGE [mm ²] REF ONLY
NORMAL	16	.100 [2.54]	.150 [3.81]	14-20 AWG [2.0-.50]
E	16	.053 [1.35]	.120 [3.05]	14-20 AWG [2.0-.50]

NOTES: 1. CONSULT FACTORY FOR ELECTRICAL AND MATERIAL SPECIFICATIONS.

SIGNATURE & DATE	
DR	X. SANCHEZ 7/30/01
CHK	<i>Spencer</i> 1/25/11
PE	<i>X. Sanchez</i> 1/25/11
APPD	<i>Spencer</i> 1/25/11
SCALE	NONE WT

RECEPTACLE SQUARE FLANGE HD10 SERIES ARR. 9-96 -B009 MOD. COLOR: GREY ENVELOPE

EP	MATL. CODE
3850 INDUSTRIAL AVE. HEMET, CA 92545	
B HD10-9-96P*-B009	
DWG SIZE	CODE SHEET OF