

User Manual

WISE-4000 Series

IoT Ethernet I/O Module

ADVANTECH

Enabling an Intelligent Planet

Copyright

The documentation and the software included with this product are copyrighted 2015 by Advantech Co., Ltd. All rights are reserved. Advantech Co., Ltd. reserves the right to make improvements in the products described in this manual at any time without notice. No part of this manual may be reproduced, copied, translated or transmitted in any form or by any means without the prior written permission of Advantech Co., Ltd. Information provided in this manual is intended to be accurate and reliable. However, Advantech Co., Ltd. assumes no responsibility for its use, nor for any infringements of the rights of third parties, which may result from its use.

Acknowledgements

Intel and Pentium are trademarks of Intel Corporation.

Microsoft Windows and MS-DOS are registered trademarks of Microsoft Corp.

All other product names or trademarks are properties of their respective owners.

Product Warranty

Advantech warrants to you, the original purchaser, that each of its products will be free from defects in materials and workmanship for two years from the date of purchase.

This warranty does not apply to any products which have been repaired or altered by persons other than repair personnel authorized by Advantech, or which have been subject to misuse, abuse, accident or improper installation. Advantech assumes no liability under the terms of this warranty as a consequence of such events.

Because of Advantech's high quality-control standards and rigorous testing, most of our customers never need to use our repair service. If an Advantech product is defective, it will be repaired or replaced at no charge during the warranty period. For out-of-warranty repairs, you will be billed according to the cost of replacement materials, service time and freight. Please consult your dealer for more details.

If you think you have a defective product, follow these steps:

1. Collect all the information about the problem encountered. (For example, CPU speed, Advantech products used, other hardware and software used, etc.) Note anything abnormal and list any onscreen messages you get when the problem occurs.
2. Call your dealer and describe the problem. Please have your manual, product, and any helpful information readily available.
3. If your product is diagnosed as defective, obtain an RMA (return merchandise authorization) number from your dealer. This allows us to process your return more quickly.
4. Carefully pack the defective product, a fully-completed Repair and Replacement Order Card and a photocopy proof of purchase date (such as your sales receipt) in a shippable container. A product returned without proof of the purchase date is not eligible for warranty service.
5. Write the RMA number visibly on the outside of the package and ship it prepaid to your dealer.

Part No. 2003D40003

Printed in Taiwan

Edition 4

May 2016

Declaration of Conformity

CE

This product has passed the CE test for environmental specifications. We recommend the use of shielded cables.

FCC Class A

Note: This equipment has been tested and found to comply with the limits for a Class A digital device, pursuant to part 15 of the FCC Rules. These limits are designed to provide reasonable protection against harmful interference when the equipment is operated in a commercial environment. This equipment generates, uses, and can radiate radio frequency energy and, if not installed and used in accordance with the instruction manual, may cause harmful interference to radio communications. Operation of this equipment in a residential area is likely to cause harmful interference in which case the user will be required to correct the interference at his own expense.

KC

해당 무선설비는 전파혼신 가능성이 있으므로 인명안전과 관련된 서비스는 할 수 없습니다

Trade name or Applicant name: Advantech

Equipment name: IoT Wireless I/O Module

Basic model name:

- WISE-4012
- WISE-4050

Certificate number:

- WISE-4012: MSIP-CRM-AK0-WISE-4012
- WISE-4050: MSIP-CRM-AK0-WISE-4050

Manufacture / Country of Origin: Advantech Taiwan

The date for certificate issue: 2016

Type of identification: Wi-Fi I/O

Technical Support and Assistance

1. Visit the Advantech web site at www.advantech.com/support where you can find the latest information about the product.
2. Contact your distributor, sales representative, or Advantech's customer service center for technical support if you need additional assistance. Please have the following information ready before you call:
 - Product name and serial number
 - Description of your peripheral attachments
 - Description of your software (operating system, version, application software, etc.)
 - A complete description of the problem
 - The exact wording of any error messages

Safety Instructions

1. Read these safety instructions carefully.
2. Keep this User Manual for later reference.
3. Disconnect this equipment from any AC outlet before cleaning. Use a damp cloth. Do not use liquid or spray detergents for cleaning.
4. For plug-in equipment, the power outlet socket must be located near the equipment and must be easily accessible.
5. Keep this equipment away from humidity.
6. Put this equipment on a reliable surface during installation. Dropping it or letting it fall may cause damage.
7. The openings on the enclosure are for air convection. Protect the equipment from overheating. **DO NOT COVER THE OPENINGS.**
8. Make sure the voltage of the power source is correct before connecting the equipment to the power outlet.
9. Position the power cord so that people cannot step on it. Do not place anything over the power cord.
10. All cautions and warnings on the equipment should be noted.
11. If the equipment is not used for a long time, disconnect it from the power source to avoid damage by transient overvoltage.
12. Never pour any liquid into an opening. This may cause fire or electrical shock.
13. Never open the equipment. For safety reasons, the equipment should be opened only by qualified service personnel.
14. If one of the following situations arises, get the equipment checked by service personnel:
 - The power cord or plug is damaged.
 - Liquid has penetrated into the equipment.
 - The equipment has been exposed to moisture.
 - The equipment does not work well, or you cannot get it to work according to the user's manual.
 - The equipment has been dropped and damaged.
 - The equipment has obvious signs of breakage.
15. **DO NOT LEAVE THIS EQUIPMENT IN AN ENVIRONMENT WHERE THE STORAGE TEMPERATURE MAY GO BELOW -20° C (-4° F) OR ABOVE 60° C (140° F). THIS COULD DAMAGE THE EQUIPMENT. THE EQUIPMENT SHOULD BE IN A CONTROLLED ENVIRONMENT.**
16. **CAUTION: DANGER OF EXPLOSION IF BATTERY IS INCORRECTLY REPLACED. REPLACE ONLY WITH THE SAME OR EQUIVALENT TYPE RECOMMENDED BY THE MANUFACTURER, DISCARD USED BATTERIES ACCORDING TO THE MANUFACTURER'S INSTRUCTIONS.**
17. The sound pressure level at the operator's position according to IEC 704-1:1982 is no more than 70 dB (A).

DISCLAIMER: This set of instructions is given according to IEC 704-1. Advantech disclaims all responsibility for the accuracy of any statements contained herein.

Contents

Chapter 1	Product Overview	1
1.1	Introduction	2
1.2	Feature Highlights	2
	1.2.1 RESTful Web Service	2
	1.2.2 Data Storage Function	3
	1.2.3 IoT Cloud Function.....	3
1.3	Series Family and Specifications	4
	1.3.1 Series Family	4
1.4	Mechanical Design and Dimensions	5
	1.4.1 WISE-4000 Wireless Series Dimensions.....	5
	1.4.2 WISE-4000/LAN Dimensions.....	5
1.5	Switch.....	6
1.6	LED Definition	6
1.7	Certification and Safety Standard	7
1.8	Package Information	8
Chapter 2	Product Specifications.....	9
2.1	General Specifications	10
2.2	WISE-4010/LAN.....	12
	2.2.1 I/O Specification.....	12
	2.2.2 Application Wiring	13
	Figure 2.1 WISE-4010/LAN Current Input Wiring Diagram	13
	Figure 2.2 WISE-4010/LAN Digital Output Wiring Diagram.....	13
	2.2.3 Pin Assignment.....	14
	Figure 2.3 WISE-4010/LAN Pin Assignment	14
	2.2.4 Block Diagram.....	14
	Figure 2.4 WISE-4010/LAN Block Diagram.....	14
2.3	WISE-4050/LAN.....	14
	2.3.1 I/O Specification.....	14
	2.3.2 Application Wiring	15
	Figure 2.5 WISE-4050/LAN Digital Input Wiring Diagram	15
	Figure 2.6 WISE-4050/LAN Digital Output Wiring Diagram.....	15
	2.3.3 Pin Assignment.....	16
	Figure 2.7 WISE-4050/LAN Pin Assignment	16
	2.3.4 Block Diagram.....	16
	Figure 2.8 WISE-4050/LAN Block Diagram.....	16
2.4	WISE-4060/LAN.....	17
	2.4.1 I/O Specification.....	17
	2.4.2 Application Wiring	18
	Figure 2.9 WISE-4060/LAN Digital Input Wiring Diagram	18
	Figure 2.10 WISE-4060/LAN Relay Output Wiring Diagram	18
	2.4.3 Pin Assignment.....	19
	Figure 2.11 WISE-4060/LAN Pin Assignment	19
	2.4.4 Block Diagram.....	19
	Figure 2.12 WISE-4060/LAN Block Diagram.....	19
2.5	WISE-4012E	20
	2.5.1 I/O Specification.....	20
	2.5.2 Application Wiring	22
	Figure 2.13 WISE-4012E Voltage Input Wiring Diagram.....	22

	Figure 2.14WISE-4012E Digital Input Wiring Diagram.....	22
	Figure 2.15WISE-4012E Relay Output Wiring Diagram.....	22
2.5.3	Pin Assignment.....	23
	Figure 2.16WISE-4012E Pin Assignment.....	23
2.5.4	Block Diagram	23
	Figure 2.17WISE-4012E Block Diagram	23
2.6	WISE-4012.....	24
2.6.1	I/O Specification.....	24
2.6.2	Application Wiring	25
	Figure 2.18WISE-4012 Analog Input Wiring Diagram	25
	Figure 2.19WISE-4012 Digital Input Wiring Diagram	25
	Figure 2.20WISE-4012 Digital Output Wiring Diagram	25
2.6.3	Pin Assignment.....	26
	Figure 2.21WISE-4012 Pin Assignment	26
2.6.4	Block Diagram	26
	Figure 2.22WISE-4012 Block Diagram.....	26
2.7	WISE-4050.....	27
2.7.1	I/O Specification.....	27
2.7.2	Application Wiring	28
	Figure 2.23WISE-4050 Digital Input Wiring Diagram	28
	Figure 2.24WISE-4050 Digital Output Wiring Diagram	28
2.7.3	Pin Assignment.....	28
	Figure 2.25WISE-4050 Pin Assignment	28
2.7.4	Block Diagram	29
	Figure 2.26WISE-4050 Block Diagram.....	29
2.8	WISE-4051.....	29
2.8.1	I/O Specification.....	29
2.8.2	Application Wiring	30
	Figure 2.27WISE-4051 Digital Input Dry Contact Wiring Diagram .	30
	Figure 2.28WISE-4051 Digital Input Wet Contact Wiring Diagram	30
	Figure 2.29RS-485 Port Wiring Diagram.....	31
2.8.3	Pin Assignment.....	31
	Figure 2.30WISE-4051 Pin Assignment	31
2.8.4	Block Diagram	31
	Figure 2.31WISE-4051 Block Diagram.....	31
2.9	WISE-4060.....	32
2.9.1	I/O Specification.....	32
2.9.2	Application Wiring	33
	Figure 2.32WISE-4060 Digital Input Wiring Diagram	33
	Figure 2.33WISE-4060 Relay Output Wiring Diagram	33
2.9.3	Pin Assignment.....	33
	Figure 2.34WISE-4060 Pin Assignment	33
2.9.4	Block Diagram	34
	Figure 2.35WISE-4060 Block Diagram.....	34

Chapter 3 Hardware Installation..... 35

3.1	Interface Introduction	36
3.2	Mounting	36
3.2.1	DIN-Rail Mounting	36
	Figure 3.1 Mounting Kit Back View.....	36
	Figure 3.2 Installing the Mounting Kit for a DIN-Rail	36
	Figure 3.3 Mounting on the DIN-Rail	37
	Figure 3.4 Rear View of DIN-Rail Mounting	37

3.2.2	Wall Mounting	38
	Figure 3.5 Mounting Kit Dimensions	38
	Figure 3.6 Wall Mounting	39
	Figure 3.7 Wall Mounting Finished	39
3.2.3	Stack Mounting	40
	Figure 3.8 Stack Mounting	40
	Figure 3.9 Finished Stack Mounting	40
3.3	Wiring & Connections	41
3.3.1	Power Supply Wiring (Not for WISE-4012E)	41
	Figure 3.10 Power Supply Wiring	41
3.3.2	USB Power (WISE-4012E Only)	41
	Figure 3.11 USB Power Supply Wiring	42
3.3.3	I/O Units	42

Chapter 4 System Configuration43

4.1	Connection	44
4.2	Configure WISE Using the Web Interface	44
4.2.1	System Requirements	44
4.2.2	List of WISE-4000 Default Ethernet Ports	45
4.2.3	Factory Default Settings	45
4.2.4	Module Authorization	45
4.2.5	Operation Mode	45
4.2.6	Using a Browser to Configure the Module	46
4.2.7	Configuring the RS-485 Port of WISE-4051	61
	Figure 4.1 Application Scenario of WISE-4051 RS-485 Port with ADAM-4000 Modbus I/O Module	66
	Table 4.1: Application Scenario of WISE-4051 RS-485 Port with ADAM-4000 Modbus I/O Module	67
4.2.8	Configuring Cloud Server (WISE-4000 wireless series only)	79
4.3	Configure WISE-4000 with ADAM.NET Utility	82
4.3.1	Operation Framework	82
4.3.2	Configure WISE-4000	87
4.4	Site Survey Tool for WISE-4000 Wireless Series	90
4.4.1	Site Survey Architecture	90
4.4.2	Site Survey Mode	90
4.4.3	Site Survey Tool	91

Appendix A I/O Modbus Mapping Table93

A.1	Modbus Function Code Introduction	94
A.2	WISE-4010/LAN Modbus Mapping Table	94
A.3	WISE-4050/LAN Modbus Mapping Table	98
A.4	WISE-4060/LAN Modbus Mapping Table	100
A.5	WISE-4012E Wireless Modbus Mapping Table	102
A.6	WISE-4012 Wireless Modbus Mapping Table	105
A.7	WISE-4050 Wireless Modbus Mapping Table	110
A.8	WISE-4051 Wireless Modbus Mapping Table	112
A.9	WISE-4060 Wireless Modbus Mapping Table	114

Appendix B REST for WISE-4000 Series117

B.1	Introduction	118
B.2	REST Resources for WISE-4000 Series	119
B.2.1	Digital Input	119

B.2.2	Digital Output.....	124
B.2.3	Analog Input.....	129
B.2.4	RS-485 Port Expansion Data.....	135
B.2.5	Data Logger.....	143

Chapter 1

Product Overview

1.1 Introduction

WISE-4000 series is an Ethernet-based wired or wireless IoT device, which integrated with IoT data acquisition, processing, and publishing functions. Except various I/O type offering, WISE-4000 series provides data pre-scaling, data logic, and data logger functions. These data can be access via mobile devices and be published to cloud with security in anytime and anywhere.



1.2 Feature Highlights

1.2.1 RESTful Web Service

Representational State Transfer (REST) is a software architecture style widely used for creating scalable web services. With the advantage of scalability, simplicity and performance, it's already adopted in IoT applications. It is based on Hypertext Transfer Protocol (HTTP) and uses verbs, like GET, POST, PUT, DELETE, etc., for web browsers to get web pages or retrieve data with remote servers. The data can be retrieved by internet media like HTML, XML, or JSON. REST s a uniform resource identifier (URI) to identify the data. Like using "http://10.0.0.1/analoginput/ch0" to identify the analog input value of channel 0. Then the web server may retrieve a JSON file analog input value of channel 0.

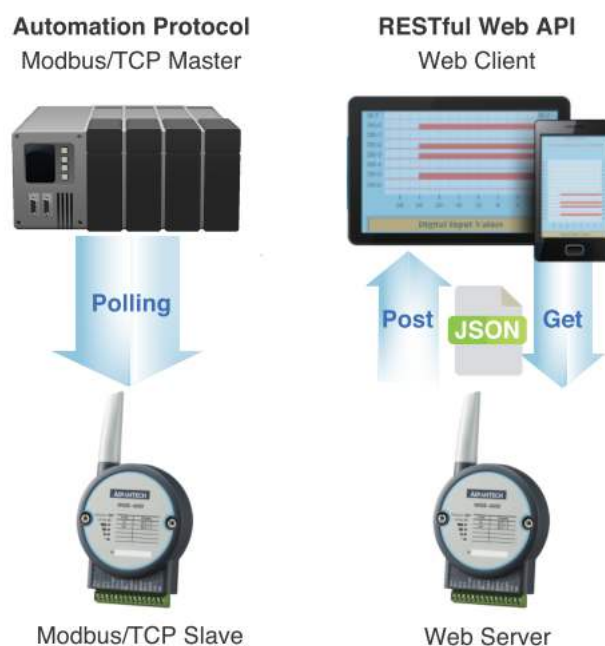

1.2.2 Data Storage Function

The internal flash of the WISE module can log up to 10,000 data samples with a time stamp. The I/O data can be logged periodically, and when the I/O status changes. Once the memory is full, users can choose to overwrite the old data to ring log or just stop the log function. When the module is powered-off, data can be kept in the module. When restarting, users can decide whether to clear all data or continue logging.

The definition of data in the IoT is not only the status of everything, but also includes time or location information. With a built-in Real Time Clock (RTC), WISE modules log data with a time stamp and the MAC address of the WISE module. The internal RTC can be calibrated by SNTP with time server. Once the module has been powered-off, the internal time can also be saved using the time backup battery. When users poll the data from the data logger, the time stamp will always be attached to the data.



1.2.3 IoT Cloud Function

Local storage data not only can be polled by the user, it can also be pushed to the cloud automatically. Once the logger reaches the upload criteria, Data Logger will push the data to public cloud services like Dropbox or Baidu. This data will be saved on the cloud using a *.csv file extension. Users can synchronize the data on the cloud using the application program provided by the cloud provider where it can be accessed from anywhere. With the provided RESTful API, users can configure their private cloud and push the data onto it. Cloud Logger provides a very flexible solution for cloud data storage. A WISE module is the only one stop from data acquisition to the cloud.



1.3 Series Family and Specifications

1.3.1 Series Family

Interface	Model	Description
WLAN	WISE-4012E	6-ch Input/Output IoT Wireless I/O Module for IoT Developers
	WISE-4012	4-ch Universal Input and 2-ch Digital Output IoT Wireless I/O Module
	WISE-4050	4-ch Digital Input and 4-ch Digital Output IoT Wireless I/O Module
	WISE-4051	8-ch Digital Input IoT Wireless I/O Module with 1-port RS-485
	WISE-4060	4-ch Digital Input and 4-ch Relay Output IoT Wireless I/O Module
LAN	WISE-4010/LAN	4-ch Current Input and 4-ch Digital Output IoT Ethernet I/O Module
	WISE-4050/LAN	4-ch Digital Input and 4-ch Digital Output IoT Ethernet I/O Module
	WISE-4060/LAN	4-ch Digital Input and 4-ch Relay Output IoT Ethernet I/O Module

1.4 Mechanical Design and Dimensions

1.4.1 WISE-4000 Wireless Series Dimensions

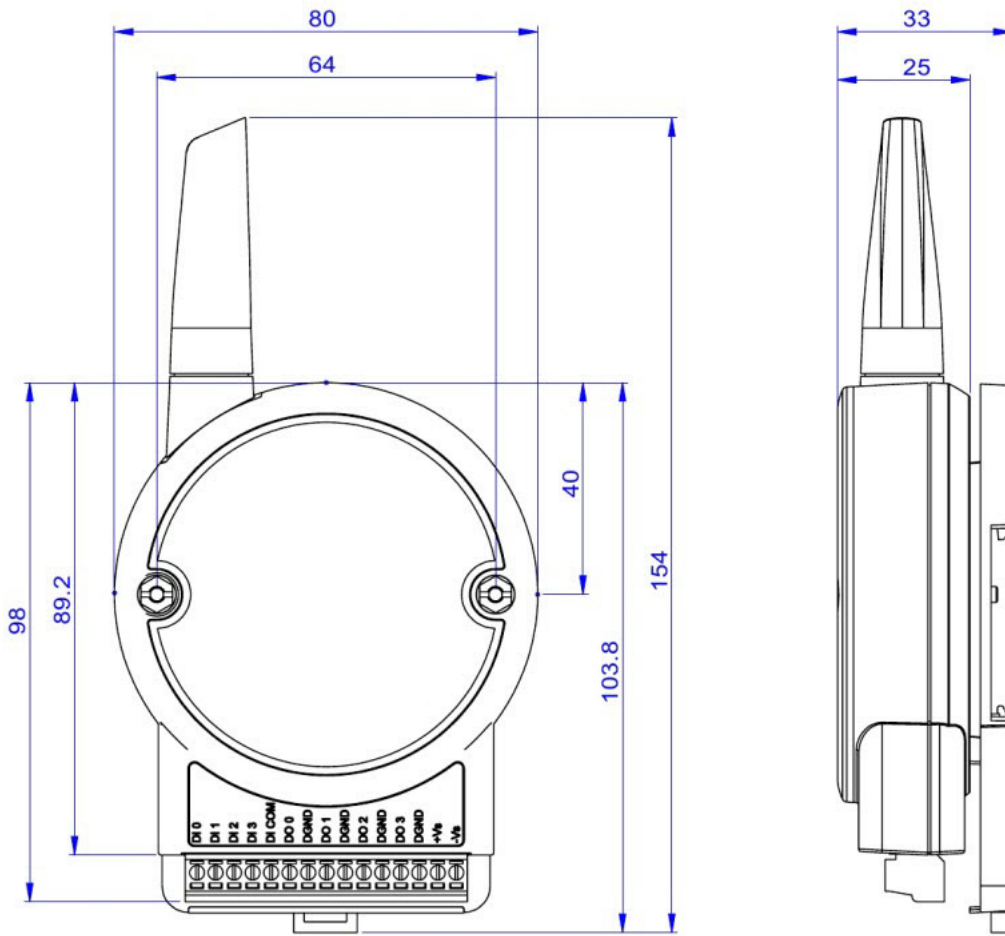

1.4.2 WISE-4000/LAN Dimensions

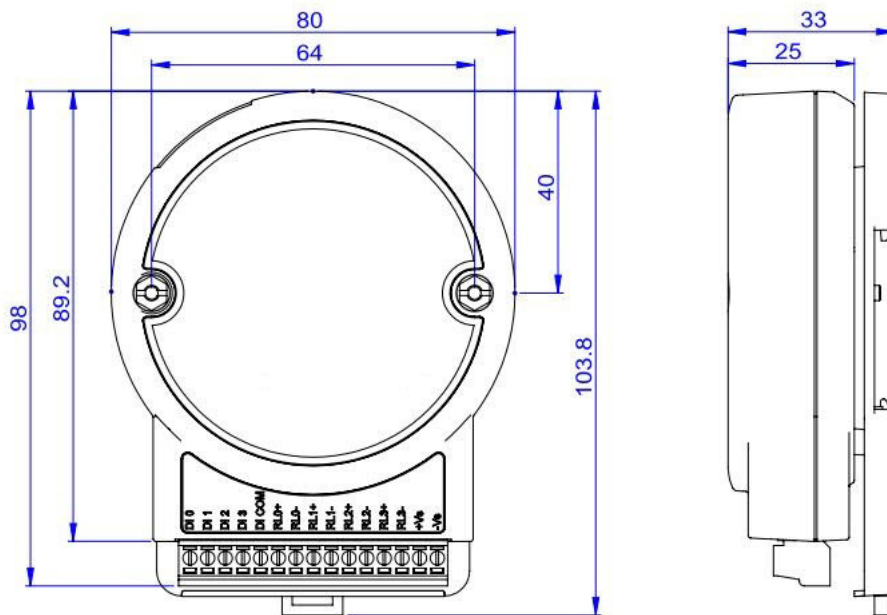

1.5 Switch

Switch	Description	Position	ON (Default)	OFF
SW1	Operation Mode	P1	Normal Mode	Initial Mode
		P2	N/A	N/A
SW2	DI Type (Ch0~3)	P1	Dry Contact	Wet Contact
		P2	Dry Contact	Wet Contact
SW3	DI Type (Ch4~7)	P1	Dry Contact	Wet Contact
		P2	Dry Contact	Wet Contact

Note 1 After the position 1 of SW1 been changed, user need to power on the module again to apply the operation mode

Note 2 SW2 is for WISE-4051, WISE-4050(/LAN), and WISE-4060(/LAN), all 4 channels have to be configured to dry contact or wet contact in the same time, and both P1 and P2 have to be changed together

Note 3 SW3 is for WISE-4051 only, all 4 channels have to be configured to dry contact or wet contact in the same time, and both P1 and P2 have to be changed together

1.6 LED Definition

■ WISE-4000 Wireless Series

LED	Color	Indication	Behavior
Status	Green	Blink	2Hz: Wait for connection 0.5Hz: Network Connected
		ON 30 Sec	When enable LOCATE function.
Com	Yellow	Blink	When TX/RX data in transmission
AP/Infra	Green	ON	Limited AP Mode
		OFF	Station Mode
Signal Strength	Green	ON *4	Full Signal
		ON *3	Good Signal
		ON *2	Okay Signal
		ON *1	Poor Signal
		All OFF	No Signal/ Limited AP Mode

■ WISE-4051 Only

LED	Color	Indication	Behavior
Tx	Yellow	Blink	RS-485 port is transmitting data
Rx	Green	Blink	RS-485 port is receiving data

■ WISE-4000/LAN Series

LED	Color	Indication	Behavior
Status	Green	Blink	Module is normally at work. (1Hz)
		ON 30 Sec	When enable LOCATE function.
Com	Yellow	Blink	When TX/RX data in transmission
Link	Green	ON	Both ends of devices are connected
Speed	Yellow	ON/OFF	ON: 100 Mbps OFF: Less than 10 Mbps

1.7 Certification and Safety Standard

WISE-4000/LAN Series

- FCC
 - FCC Part 15 Class A
 - IC ICES-003
- CE
 - EN 55011 (Group 1, CLASS A)
 - EN 55022
 - EN 61000-6-4
 - EN 61000-6-2
 - IEC 61000-4-2
 - IEC 61000-4-3
 - IEC 61000-4-4
 - IEC 61000-4-5
 - IEC 61000-4-6
 - IEC 61000-4-8
 - IEC 61000-4-11
 - RoHS
- China RoHS

WISE-4000 Wireless Series

- FCC
 - FCC Part 15 Class A
 - IC ICES-003
- CE
 - EN 55011 (Group 1, CLASS A)
 - EN 55022
 - EN 61000-6-4
 - EN 61000-6-2
 - IEC 61000-4-2
 - IEC 61000-4-3
 - IEC 61000-4-4
 - IEC 61000-4-5
 - IEC 61000-4-6
 - IEC 61000-4-8
 - IEC 61000-4-11
 - RoHS
- NCC
- SRRC
- China RoHS

1.8 Package Information

WISE-4000 Wireless Series

- WISE-4000 Module with bundle antenna and terminal connector x1
- Mounting bracket x1
- Quick startup manual with China RoHS declare

WISE-4000/LAN Series

- WISE-4000/LAN Module
- Mounting bracket x1
- Quick startup manual with China RoHS declare

WISE-4012

- WISE-4000 Module with bundle antenna and terminal connector x1
- Mounting bracket x1
- Quick startup manual with China RoHS declare
- 120Ohm precise resistors

WISE-4012E

- WISE-4012E Module with bundle antenna and terminal connector x1
- Quick startup manual with China RoHS declare
- USB drive with WebAccess (WISE-4012E-AE-WA only)
- USB power cable
- Extension board
- Screwdriver

Chapter 2

Product Specifications

2.1 General Specifications

WLAN Interface

- Standard Conformance:
 - 802.11b
 - 802.11g
 - 802.11n (2.4GHz only)
- Network Modes:
 - Limited AP (Wireless Server)
 - Station/Infrastructure (Wireless Client)
- Transmission Distance: 110 meters (In open areas with bundled external antenna)
- Wireless Security: WPA2 Personal & Enterprise
- Transmit Power
 - 802.11b: 15.00 dBm
 - 802.11g: 16.45 dBm
 - 802.11n: 16.39 dBm
- Antenna
 - Connector: Reverse SMA
 - Gain (Peak): 3.26 dBi

LAN Interface (WISE-4000/LAN Series)

- Ethernet: IEEE 802.3u 10/100Base-T(X)
- Connector: 1-port RJ-45

General

- I/O Connector: 3.5mm spacing, 15-pole, plug-in screw terminal block
- Power Connector: Micro-B USB for WISE-4012E, other modules use same connector as I/O
- Watchdog Timer
 - System: 1.6 second
 - Communication
 - Programmable (FSV)
- RTC Accuracy: 3 min/month (WISE-4012E does not provide RTC)
- Enclosure: PC
- Mounting: DIN 35 rail, wall, and stack
- Dimensions (W x H x D)
 - With bundle antenna: 80 x 148 x 25 mm
 - Without bundled antenna: 80 x 89 x 25 mm
- Operation Temperature:
 - WISE-4000 Wireless Series: -25~70°C (-13~158°F)
 - WISE-4000/LAN Series: -40~70°C (-40~158°F)
- Cold Start Temperature
 - WISE-4000 Wireless Series: -20~70°C (-4~158°F)
 - WISE-4000/LAN Series: -40~70°C (-40~158°F)
- Storage Temperature: -40~85°C (-40~185°F)
- Operating Humidity: 20~ 95% RH (non-condensing)

- Storage Humidity: 0~95% RH (non-condensing)

Note! *Equipment will operate below 30% humidity. However, static electricity problems occur much more frequently at lower humidity levels. Make sure you take adequate precautions when you touch the equipment. Consider using ground straps, anti-static floor coverings, etc. if you use the equipment in low humidity environments.*



Power

- Power Input Voltage
 - WISE-4012E: USB 5VDC
 - WISE-4012: 10~30 VDC (24 VDC Standard)
 - WISE-4050: 10~30 VDC (24 VDC Standard)
 - WISE-4051: 10~30 VDC (24 VDC Standard)
 - WISE-4060: 10~30 VDC (24 VDC Standard)
 - WISE-4010/LAN: 10~30 VDC (24 VDC Standard)
 - WISE-4050/LAN: 10~30 VDC (24 VDC Standard)
 - WISE-4060/LAN: 10~30 VDC (24 VDC Standard)
- Power Consumption
 - WISE-4012E: 2.2 W @ 5 VDC
 - WISE-4012: 2.5 W @ 24 VDC
 - WISE-4050: 2.2 W @ 24 VDC
 - WISE-4051: 2.2 W @ 24 VDC
 - WISE-4060: 2.5 W @ 24 VDC
 - WISE-4010/LAN: 1.2 W @ 24 VDC
 - WISE-4050/LAN: 2.2 W @ 24 VDC
 - WISE-4060/LAN: 2.5 W @ 24 VDC
- Reverse Power Protection (not for WISE-4012E)

Software

- Configuration Interface: Web Interface, Windows Utility
- Utility: WISE-4000/Apax .NET Utility
- Driver: WISE-4000 .NET Class Library
- Industrial Protocol: Modbus/TCP
- Supported Protocols: TCP/IP, UDP, HTTP, HTTPS, DHCP, ARP, SNTP
- Supports RESTful Web API in JSON format
- Supports Web Server in HTML5 with JavaScript & CSS3

Note! *RTC Accuracy: 3 min/month (WISE-4012E does not provide RTC)*



2.2 WISE-4010/LAN

2.2.1 I/O Specification

- Current Input
 - Channel: 4
 - Resolution: 12-bit
 - Sampling Rate: 10/100 Hz/channel
 - Accuracy: $\pm 0.2\%$ of FSR @ 25°C
 - Input Range: 0~20 mA, 4~20 mA (Select by Web Configuration)
 - Input Impedance: 120 Ω
 - Burn-out Detection: Yes (4~20 mA only)
 - Supports Data Scaling and Averaging

- Digital Output
 - Channels: 4
 - Open collector to 30 V, 400 mA max. for resistance load
 - Inductive loads require an external diode to eliminate back-EMF when the DO is turned off
 - On Resistance ($R_{DS(ON)}$): 0.7 Ω (max.) @ 400mA, 25°C, 10V
 - Supports 5 kHz Pulse Output
 - Supports High-to-Low and Low-to-High Delay Output

2.2.2 Application Wiring

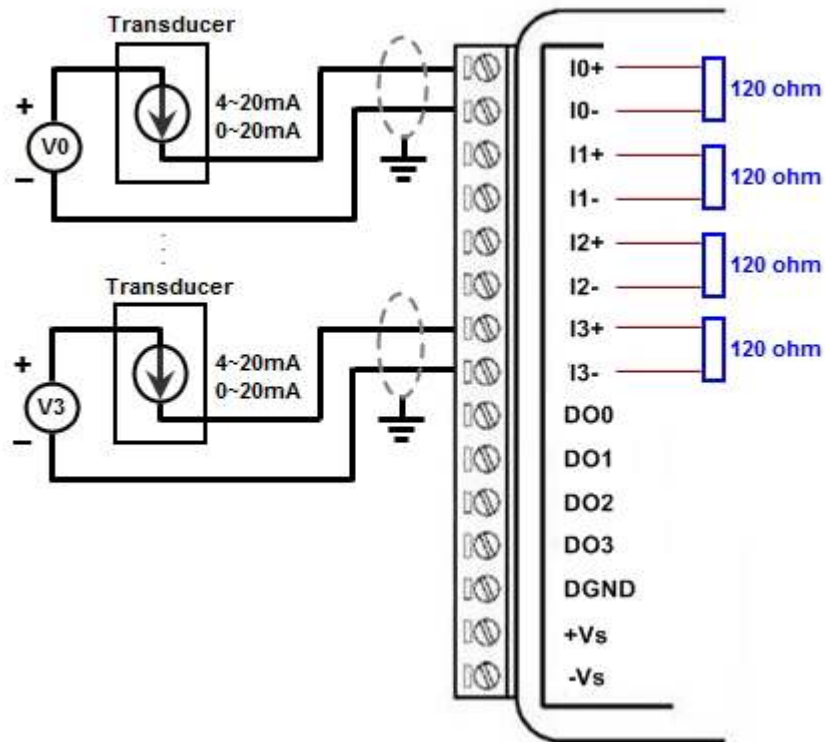

Figure 2.1 WISE-4010/LAN Current Input Wiring Diagram

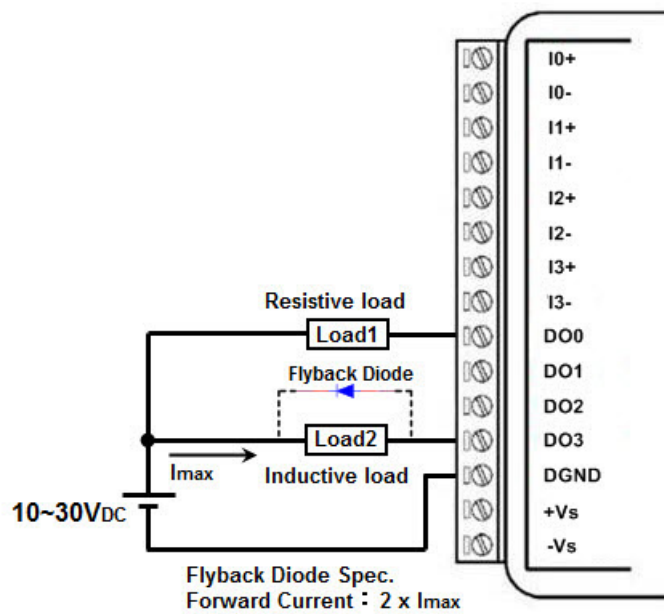

Figure 2.2 WISE-4010/LAN Digital Output Wiring Diagram

2.2.3 Pin Assignment

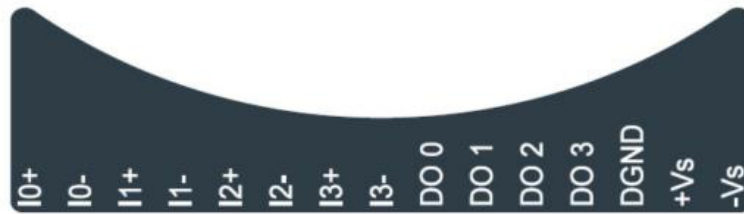

Figure 2.3 WISE-4010/LAN Pin Assignment

2.2.4 Block Diagram

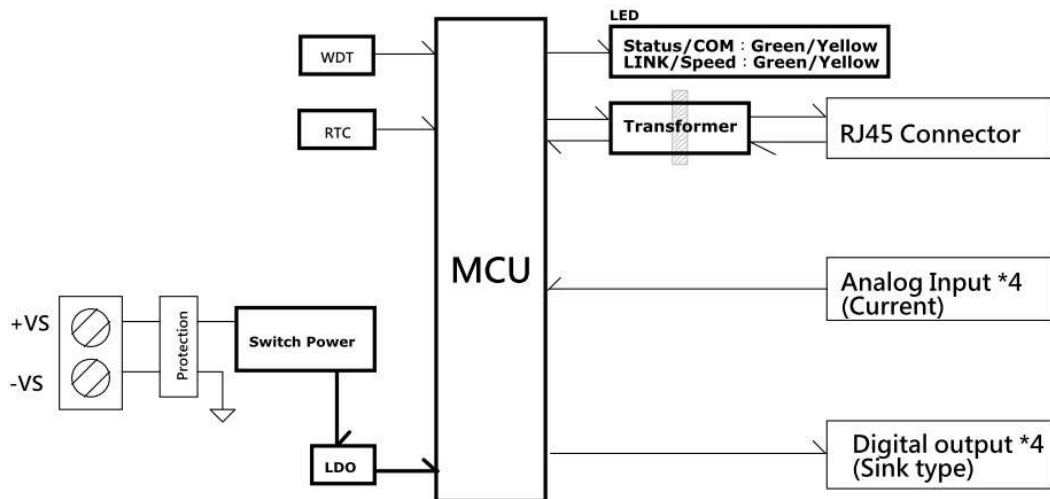

Figure 2.4 WISE-4010/LAN Block Diagram

2.3 WISE-4050/LAN

2.3.1 I/O Specification

- Digital Input
 - Channel: 4
 - Logic level
 - Dry Contact 0: Open
1: Close to DI COM
 - Wet Contact 0: 0~3 V_{DC} or -3~0 V_{DC}
1: 10~30 V_{DC} or -30~-10 V_{DC} (3 mA min.)
 - All 4 channels should be configured to dry contact or wet contact in the same time
 - Isolation: 3,000 V_{rms}
 - Supports 32-bit Counter Input Function (Maximum signal frequency 3 kHz)
 - Keep/Discard Counter Value when Power-off
 - Supports Frequency Input Function (Maximum frequency 3 kHz)
 - Supports Inverted DI Status

Digital Output

- Channels: 4
- Open collector to 30 V, 400 mA max. for resistance load
- Inductive loads require an external diode to eliminate back-EMF when the DO is turned off
- Isolation: 3,000 V_{rms}
- On Resistance ($R_{DS(ON)}$): 0.7 Ω (max.) @ 400mA, 25°C, 10V
- Supports 5 kHz Pulse Output
- Supports High-to-Low and Low-to-High Delay Output

2.3.2 Application Wiring

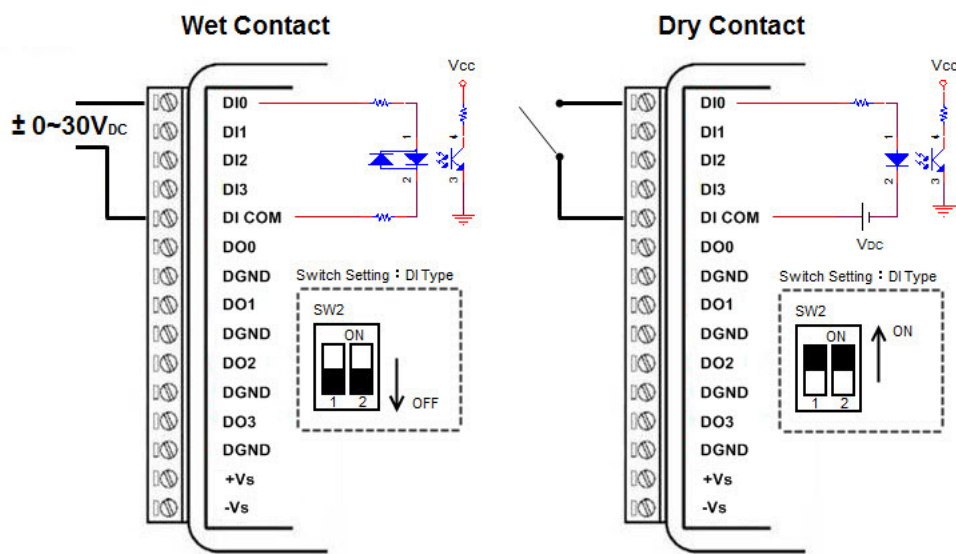

Figure 2.5 WISE-4050/LAN Digital Input Wiring Diagram

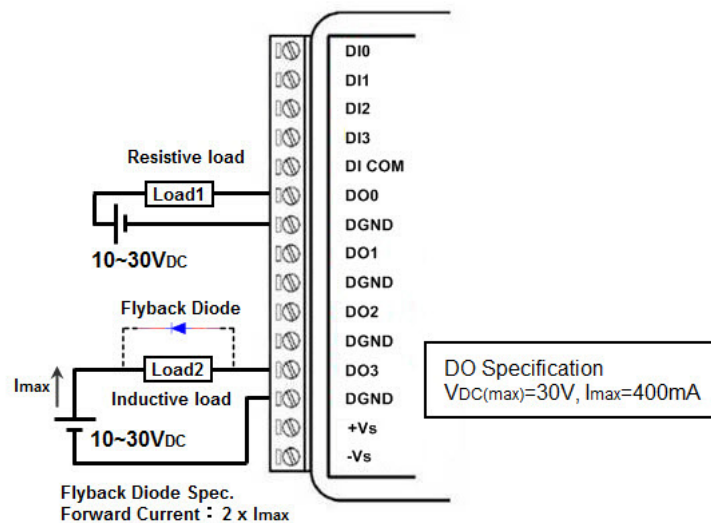

Figure 2.6 WISE-4050/LAN Digital Output Wiring Diagram

2.3.3 Pin Assignment

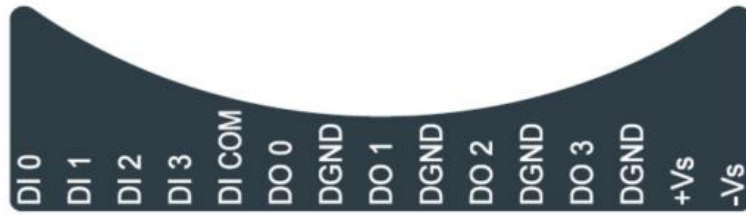

Figure 2.7 WISE-4050/LAN Pin Assignment

2.3.4 Block Diagram

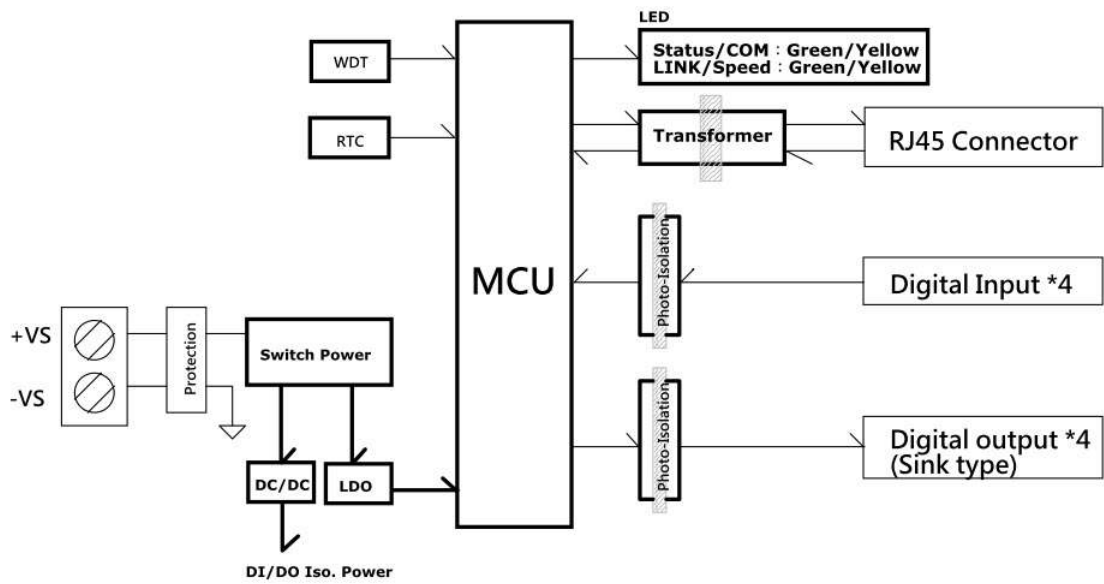

Figure 2.8 WISE-4050/LAN Block Diagram

2.4 WISE-4060/LAN

2.4.1 I/O Specification

- Digital Input
 - Channel: 4
 - Logic level
 - Dry Contact 0: Open
1: Close to DI COM
 - Wet Contact 0: 0~3 V_{DC} or -3~0 V_{DC}
1: 10~30 V_{DC} or -30~-10 V_{DC} (3 mA min.)
 - Isolation: 3,000 V_{rms}
 - Supports 32-bit Counter Input Function (Maximum signal frequency 3 kHz)
 - Keep/Discard Counter Value when Power-off
 - Supports Frequency Input Function (Maximum frequency 3 kHz)
 - Supports Inverted DI Status

Relay Output

- Channels: 4 (Form A)
- Contact Rating (Resistive Load)
 - 250 V_{AC} @ 5 A
 - 30 V_{DC} @ 3 A
- Relay On Time: 10 ms
- Relay Off Time: 5 ms
- Insulation Resistance: 1 GΩ min. @ 500 V_{DC}
- Dielectric Strength
 - Between Contacts: 1000 V_{AC} (1min)
 - Between Coil to Contact: 3000 V_{AC} (1min)
- Maximum Switching: 60 operations/minute
- Supports Pulse Output
- Supports High-to-Low and Low-to-High Delay Output

2.4.2 Application Wiring

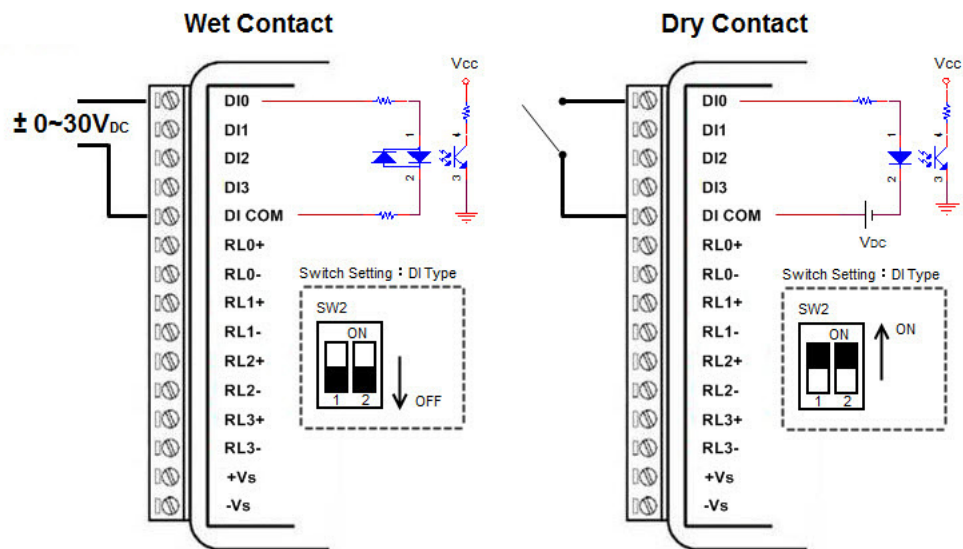

Figure 2.9 WISE-4060/LAN Digital Input Wiring Diagram

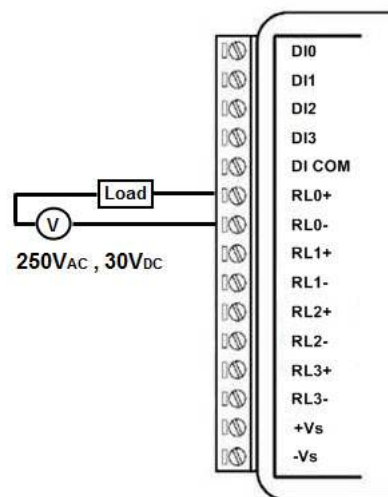

Figure 2.10 WISE-4060/LAN Relay Output Wiring Diagram

2.4.3 Pin Assignment

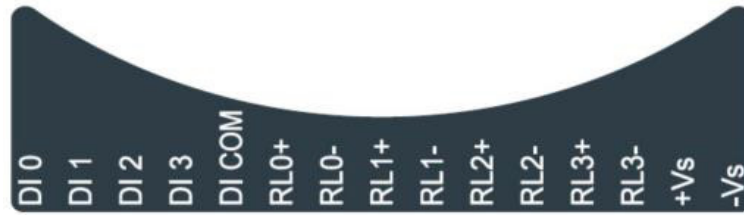

Figure 2.11 WISE-4060/LAN Pin Assignment

2.4.4 Block Diagram

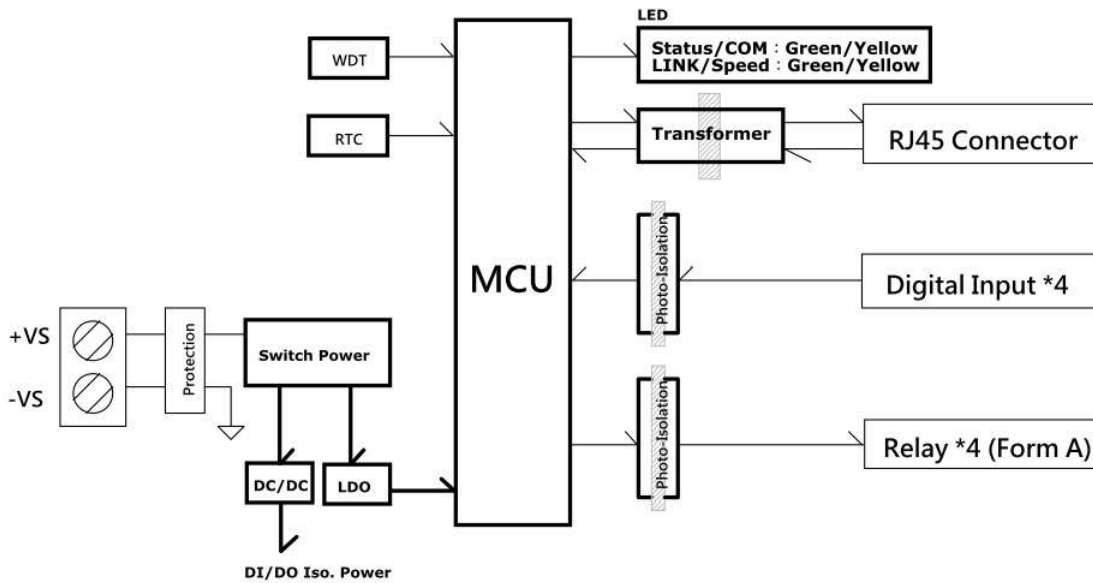

Figure 2.12 WISE-4060/LAN Block Diagram

2.5 WISE-4012E

2.5.1 I/O Specification

- Voltage Input
 - Channel: 2
 - Resolution: 12-bit
 - Sampling Rate: 10 Hz (Total)
 - Accuracy: $\pm 0.1 V_{DC}$
 - Input Range: $0 \sim 10 V_{DC}$
 - Input Impedance: 100 k Ω
 - Supports Data Scaling and Averaging

- Digital Input
 - Channel: 2
 - Logic level
 - Dry Contact 0: Open
 - 1: Close to GND
 - Supports 32-bit Counter Input Function (Maximum signal frequency 3 kHz)
 - Keep/Discard Counter Value when Power-off
 - Supports Frequency Input Function (Maximum frequency 3 kHz)
 - Supports Inverted DI Status

- Relay Output
 - Channels: 2 (Form A)
 - Contact Rating
 - $120 V_{AC}$ @ 0.5 A
 - $30 V_{DC}$ @ 1A
 - Relay On Time: 5 ms
 - Relay Off Time: 6 ms
 - Insulation Resistance: 1 G Ω min. @ 500 V_{DC}
 - Dielectric Strength
 - Between Contacts: 1000 V_{AC} (1min)
 - Between Coil to Contact: 1500 V_{AC} (1min)
 - Maximum Switching: 60 operations/minute
 - Supports Pulse Output
 - Supports High-to-Low and Low-to-High Delay Output

Note! *The analog input channels of the WISE-4012E do not support 50/60 Hz noise rejection. The following methods can help to reduce noise:*



- Power up WISE-4012E by power bank
- Supply sensor power by battery
- Wiring V0- and V1- pin to GND pin

Note! *The analog input channel of the WISE-4012E does not support inverted voltage protection, note that the input voltage should within $0\sim 10V_{DC}$*



2.5.2 Application Wiring

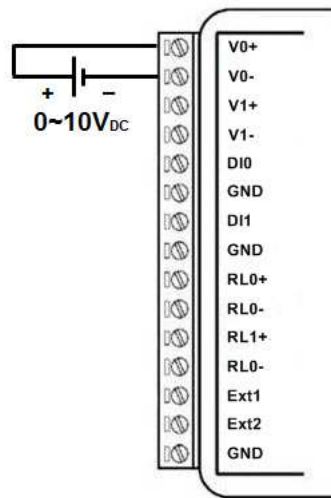

Figure 2.13 WISE-4012E Voltage Input Wiring Diagram

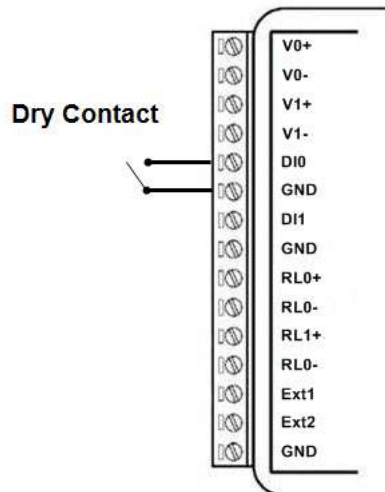

Figure 2.14 WISE-4012E Digital Input Wiring Diagram

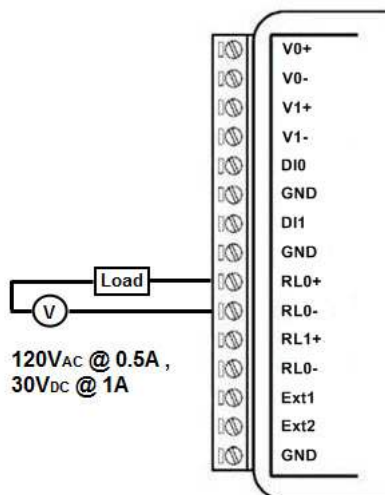

Figure 2.15 WISE-4012E Relay Output Wiring Diagram

2.5.3 Pin Assignment

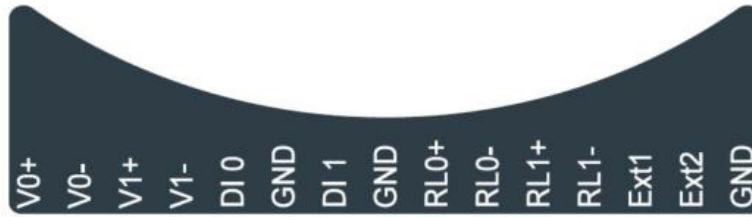

Figure 2.16 WISE-4012E Pin Assignment

2.5.4 Block Diagram

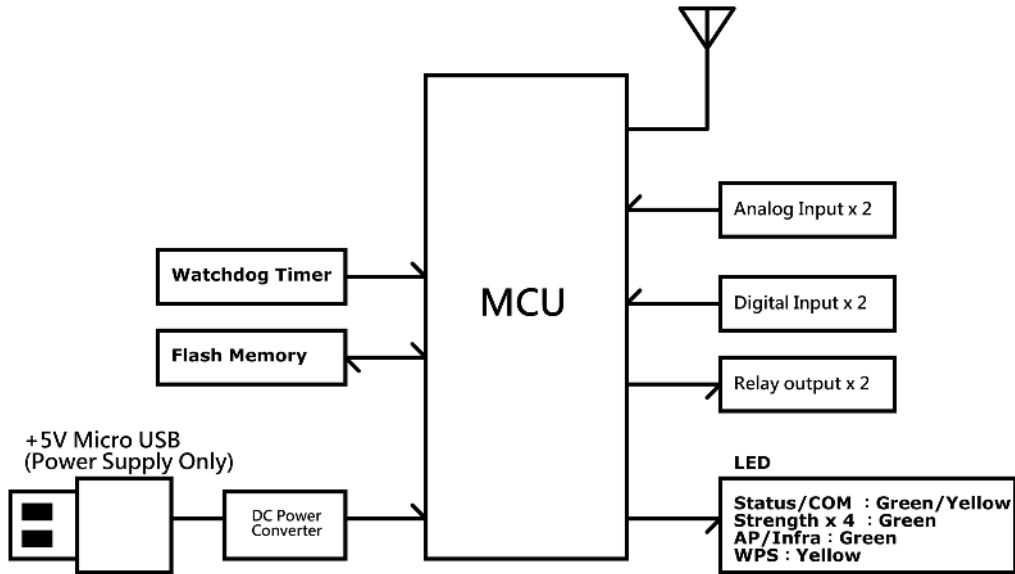

Figure 2.17 WISE-4012E Block Diagram

2.6 WISE-4012

2.6.1 I/O Specification

- Universal Input
 - Channel: 4
 - Resolution: 16-bit
 - Sampling Rate*
 - Universal Input 10Hz (Total)
 - Digital Input 2Hz (Per Channel)
 - Accuracy
 - Voltage $\pm 0.1\%$ of FSR
 - Current $\pm 0.2\%$ of FSR**
 - Input Type and Range
 - Voltage Input $\pm 150\text{mV}$, $\pm 500\text{mV}$, $\pm 1\text{V}$, $\pm 5\text{V}$, $\pm 10\text{V}$,
 $0\sim 150\text{mV}$, $0\sim 500\text{mV}$, $0\sim 1\text{V}$, $0\sim 5\text{V}$, $0\sim 10\text{V}$,
 - Current Input $0\sim 20\text{mA}$, $4\sim 20\text{mA}$, $\pm 20\text{mA}$
 - Digital Input (Dry Contact) 0: Open (Resistance $> 1.5\text{k}\Omega$)
1: Close to GND (Resistance $< 300\ \Omega$)
 - Input Impedance:
 - Voltage $> 10\text{M}\ \Omega$
 - Current $120\ \Omega$ (Need external resistor**)
 - Burn-out Detection for $4\sim 20\ \text{mA}$ input range
 - Supports Data Scaling and Averaging

* When the universal channel been configured as digital input, it will also share the sampling rate of analog input. And please be noted that the maximum sampling rate of digital input is 2Hz.

** For accuracy assurance in current mode, please use the $120\ \Omega$ precise resistors in the package list.

- Digital Output
 - Channel: 2
 - Open collector to 30 V, 400 mA max. for resistance load
 - Inductive loads require an external diode to eliminate back-EMF when the DO is turned off
 - Isolation: 3,000 Vrms
 - On Resistance ($R_{\text{DS(ON)}}$): $0.7\ \Omega$ (max.) @ 200mA, 25°C , 5V
 - Supports 5 kHz Pulse Output
 - Supports High-to-Low and Low-to-High Delay Output

2.6.2 Application Wiring

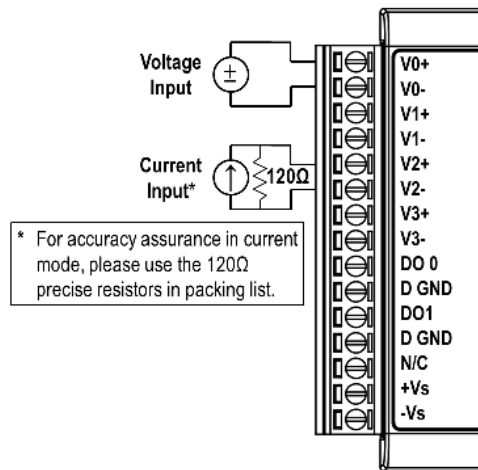

Figure 2.18 WISE-4012 Analog Input Wiring Diagram

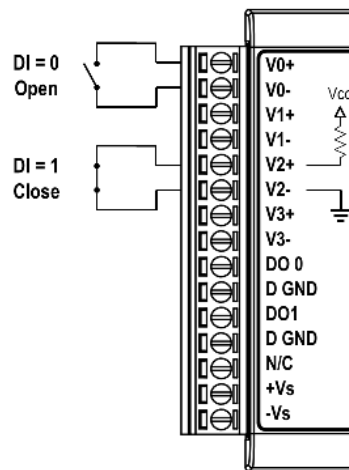

Figure 2.19 WISE-4012 Digital Input Wiring Diagram

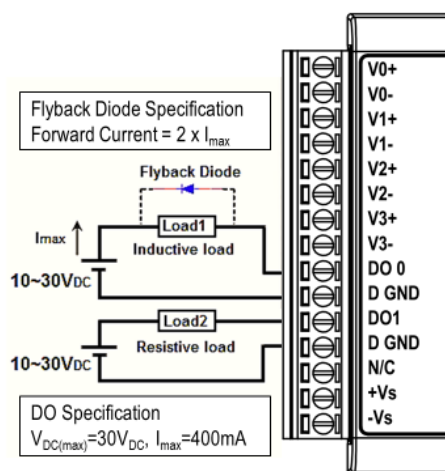

Figure 2.20 WISE-4012 Digital Output Wiring Diagram

2.6.3 Pin Assignment

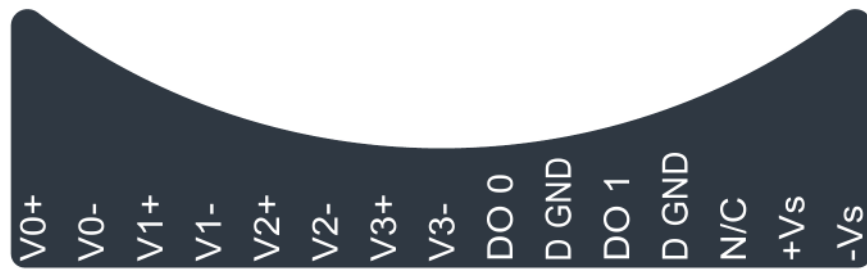

Figure 2.21 WISE-4012 Pin Assignment

2.6.4 Block Diagram

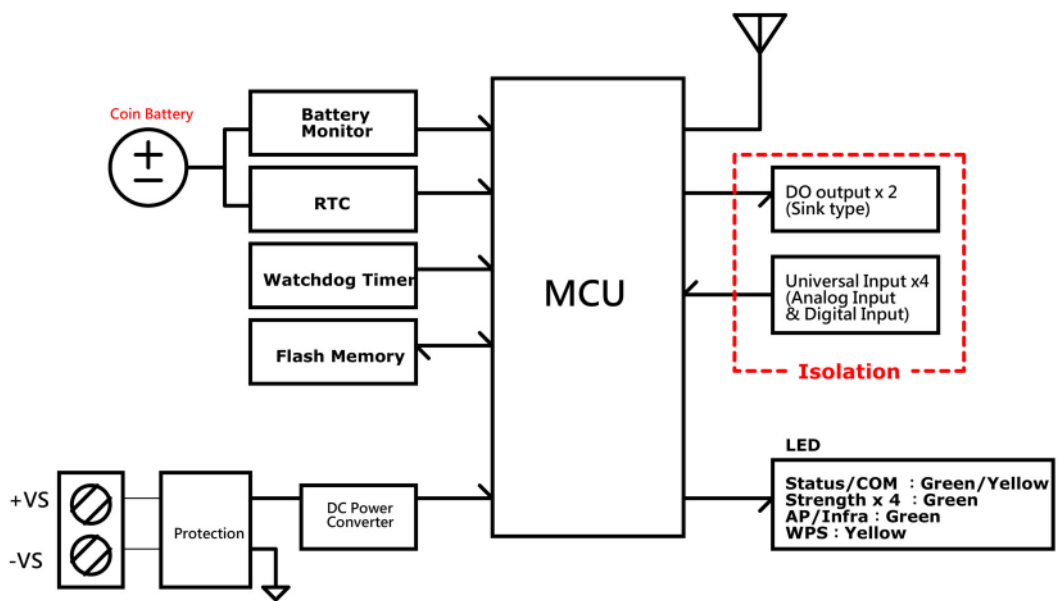

Figure 2.22 WISE-4012 Block Diagram

2.7 WISE-4050

2.7.1 I/O Specification

- Digital Input
 - Channel: 4
 - Logic level
 - Dry Contact 0: Open
 - 1: Close to DI COM
 - Wet Contact 0: $0\sim 3 V_{DC}$ or $-3\sim 0 V_{DC}$
 - 1: $10\sim 30 V_{DC}$ or $-30\sim -10 V_{DC}$ (3 mA min.)
 - All 4 channels should be configured to dry contact or wet contact in the same time
 - Isolation: $3,000 V_{rms}$
 - Supports 32-bit Counter Input Function (Maximum signal frequency 3 kHz)
 - Keep/Discard Counter Value when Power-off
 - Supports Frequency Input Function (Maximum frequency 3 kHz)
 - Supports Inverted DI Status

- Digital Output
 - Channels: 4
 - Open collector to 30 V, 500 mA max. for resistance load
 - Inductive loads require an external diode to eliminate back-EMF when the DO is turned off
 - Isolation: $3,000 V_{rms}$
 - On Resistance ($R_{DS(ON)}$): 0.7Ω (max.) @ 500mA, $25^{\circ}C$
 - Supports 5 kHz Pulse Output
 - Supports High-to-Low and Low-to-High Delay Output

2.7.2 Application Wiring

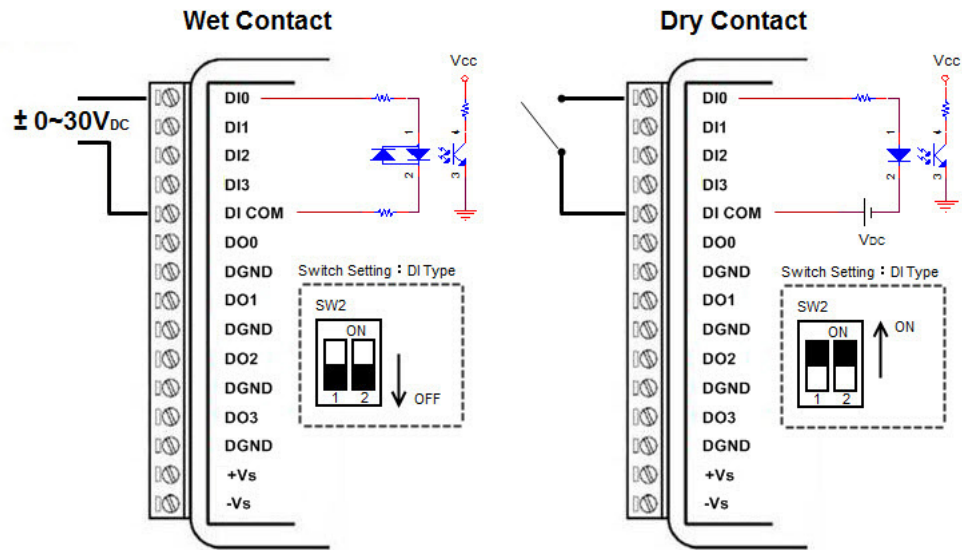

Figure 2.23 WISE-4050 Digital Input Wiring Diagram

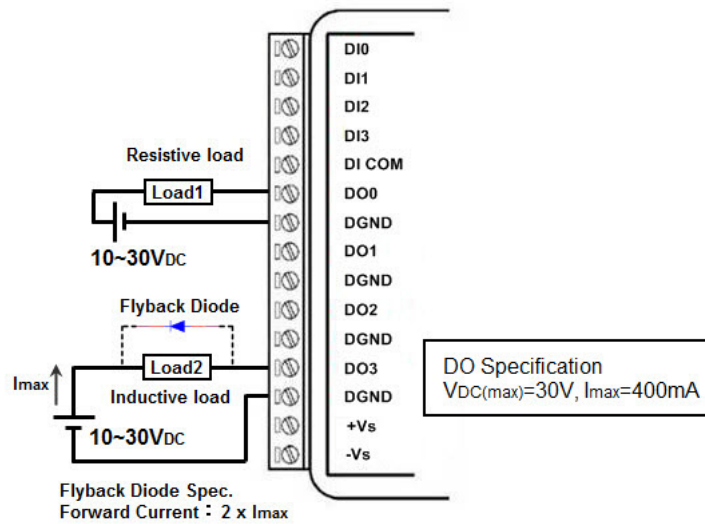

Figure 2.24 WISE-4050 Digital Output Wiring Diagram

2.7.3 Pin Assignment

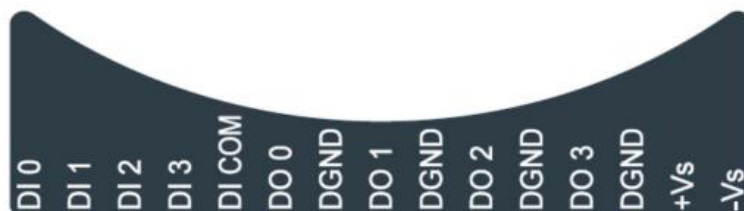

Figure 2.25 WISE-4050 Pin Assignment

2.7.4 Block Diagram

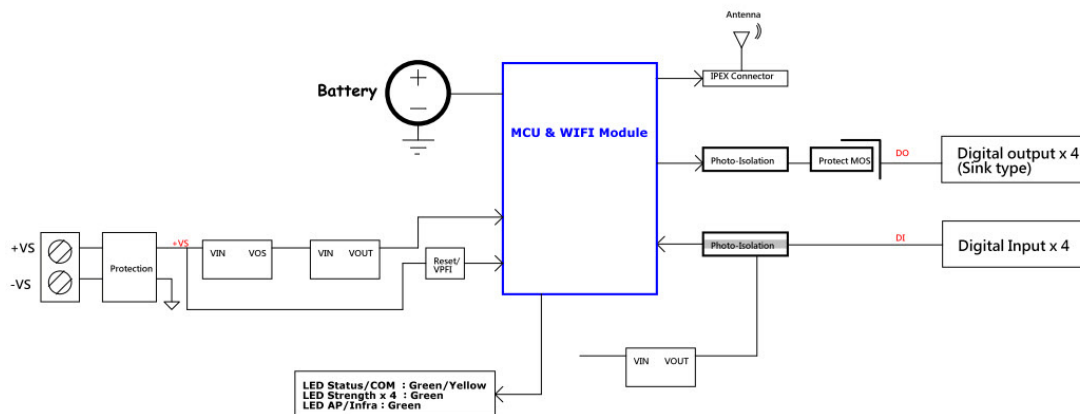

Figure 2.26 WISE-4050 Block Diagram

2.8 WISE-4051

2.8.1 I/O Specification

- Digital Input
 - Channel: 8
 - Logic level
 - Dry Contact 0: Open
 - 1: Close to DI COM
 - Wet Contact 0: 0~3 V_{DC} or -3~0 V_{DC}
 - 1: 10~30 V_{DC} or -30~-10 V_{DC} (3 mA min.)
 - Channel 0~3 should be configured to dry contact or wet contact in the same time
 - Channel 4~7 should be configured to dry contact or wet contact in the same time
 - Isolation: 3,000 V_{rms}
 - Supports 32-bit Counter Input Function (Maximum signal frequency 3 kHz)
 - Keep/Discard Counter Value when Power-off
 - Supports Frequency Input Function (Maximum frequency 3 kHz)
 - Supports Inverted DI Status
- RS-485 Port
 - Number of Ports: 1
 - Port Connector: 3.5mm spacing plug-in screw terminal block (shared with I/O and power)
 - Baud Rate (bps): 1200, 2400, 4800, 9600, 19200, 38400, 57600, 115200
 - Data Bits: 7, 8
 - Stop Bits: 1, 2
 - Parity: None, Odd, Even
 - Flow Control: Auto flow control
 - Signals: DATA+ and DATA-
 - Protection: 15 kV ESD
 - Supported Protocol:
 - Modbus/RTU (Total 32 address by max. 8 instructions)

2.8.2 Application Wiring

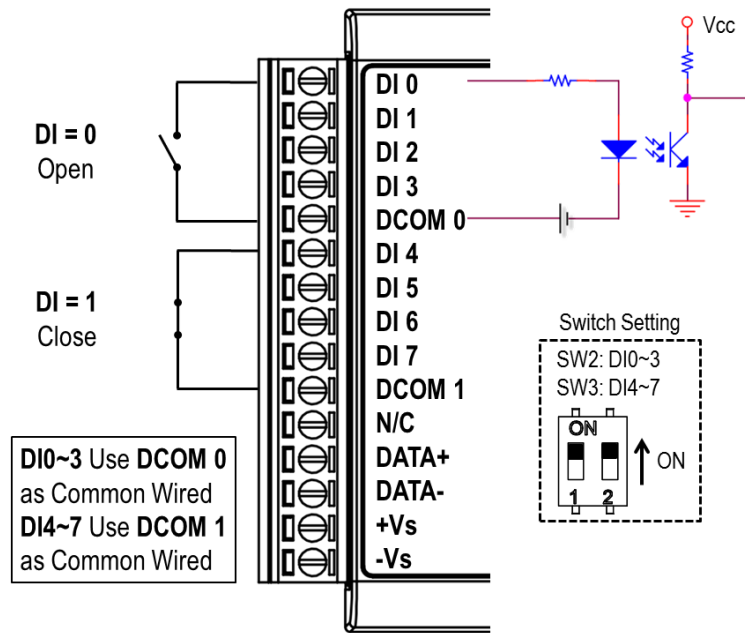

Figure 2.27 WISE-4051 Digital Input Dry Contact Wiring Diagram

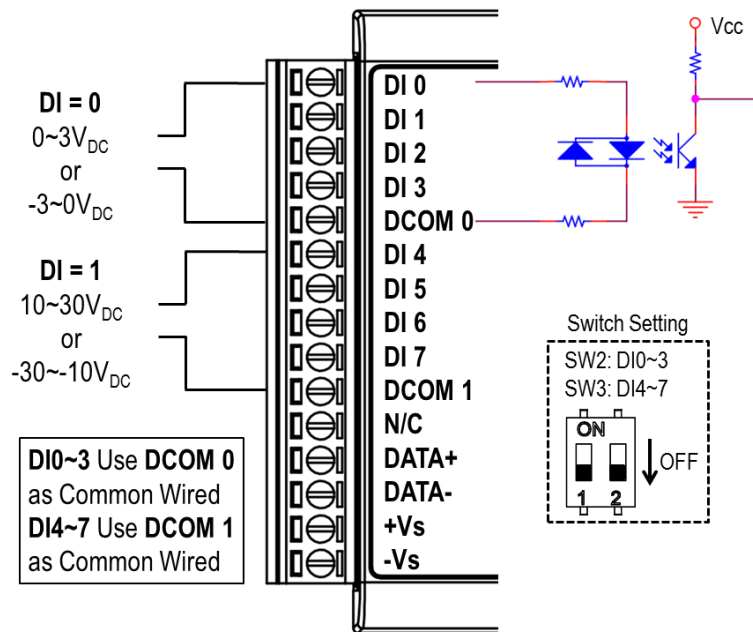

Figure 2.28 WISE-4051 Digital Input Wet Contact Wiring Diagram

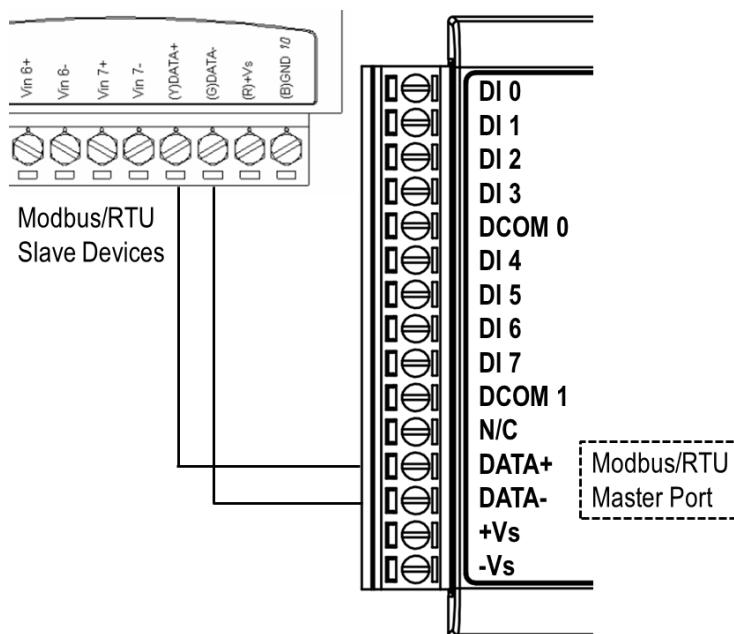

Figure 2.29 RS-485 Port Wiring Diagram

2.8.3 Pin Assignment



Figure 2.30 WISE-4051 Pin Assignment

2.8.4 Block Diagram

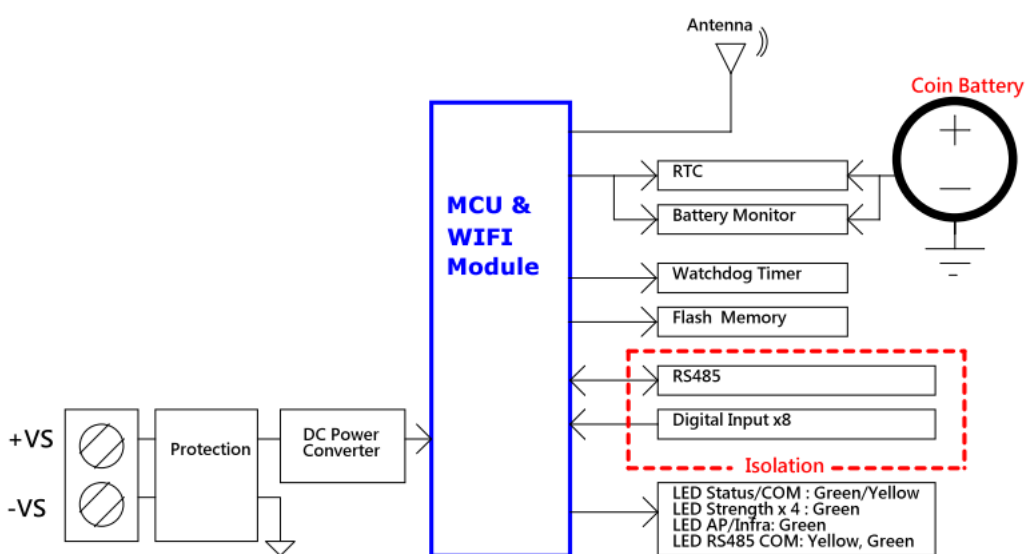

Figure 2.31 WISE-4051 Block Diagram

2.9 WISE-4060

2.9.1 I/O Specification

- Digital Input
 - Channel: 4
 - Logic level
 - Dry Contact 0: Open
1: Close to DI COM
 - Wet Contact 0: 0~3 V_{DC} or -3~0 V_{DC}
1: 10~30 V_{DC} or -30~-10 V_{DC} (3 mA min.)
 - Isolation: 3,000 V_{rms}
 - Supports 32-bit Counter Input Function (Maximum signal frequency 3 kHz)
 - Keep/Discard Counter Value when Power-off
 - Supports Frequency Input Function (Maximum frequency 3 kHz)
 - Supports Inverted DI Status
- Relay Output
 - Channels: 4 (Form A)
 - Contact Rating (Resistive Load)
 - 250 V_{AC} @ 5 A
 - 30 V_{DC} @ 3 A
 - Relay On Time: 10 ms
 - Relay Off Time: 5 ms
 - Insulation Resistance: 1 GΩ min. @ 500 V_{DC}
 - Dielectric Strength
 - Between Contacts: 1000 V_{AC} (1min)
 - Between Coil to Contact: 3000 V_{AC} (1min)
 - Maximum Switching: 60 operations/minute
 - Supports Pulse Output
 - Supports High-to-Low and Low-to-High Delay Output

2.9.2 Application Wiring

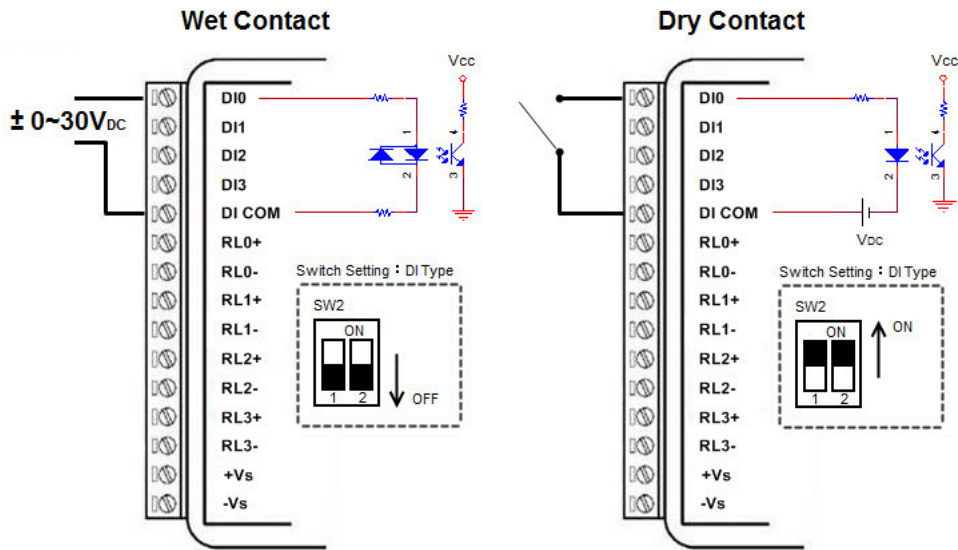

Figure 2.32 WISE-4060 Digital Input Wiring Diagram

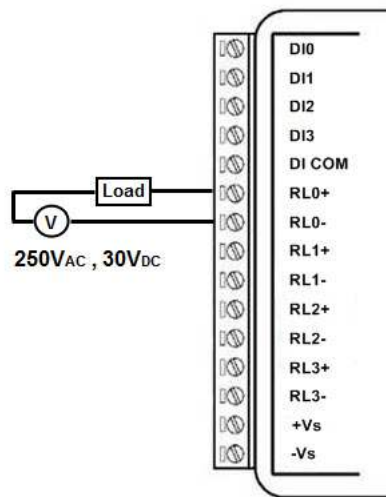

Figure 2.33 WISE-4060 Relay Output Wiring Diagram

2.9.3 Pin Assignment



Figure 2.34 WISE-4060 Pin Assignment

2.9.4 Block Diagram

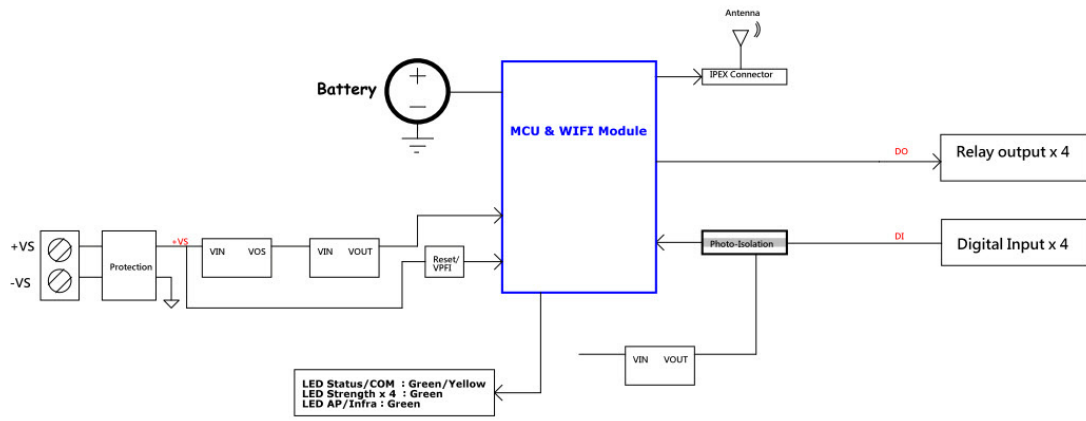

Figure 2.35 WISE-4060 Block Diagram

Chapter 3

Hardware Installation

3.1 Interface Introduction

3.2 Mounting

WISE-4000 modules are designed as compact units and are allowed to be installed in the field site under the following methods.

3.2.1 DIN-Rail Mounting

The WISE-4000 module can also be fixed to the cabinet by using mounting rails. You need to assemble the DIN rail adapter to WISE-4000 module with flathead screw driver as below. When the module is mounted on a rail, you may also consider using end brackets at each end of the rail to keep the module from sliding horizontally along the rail.

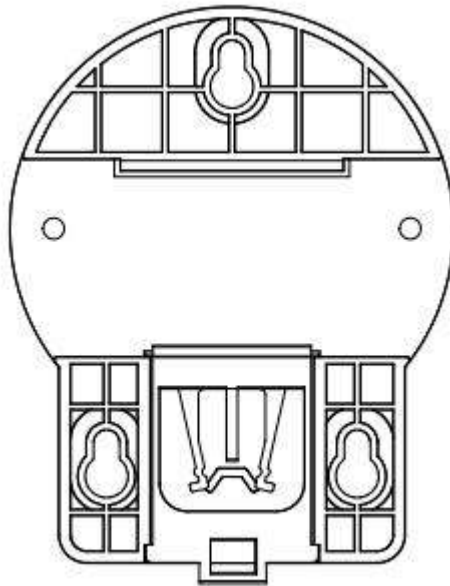

Figure 3.1 Mounting Kit Back View

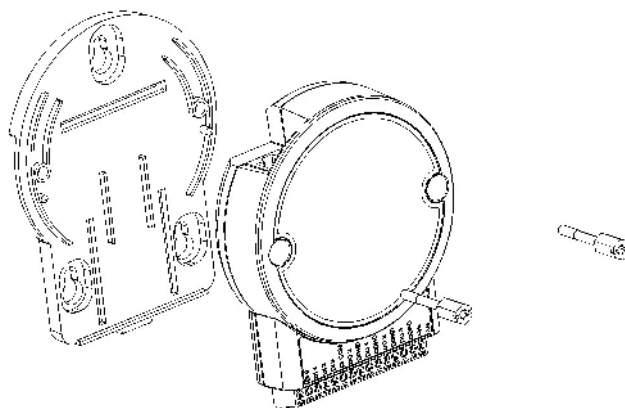

Figure 3.2 Installing the Mounting Kit for a DIN-Rail

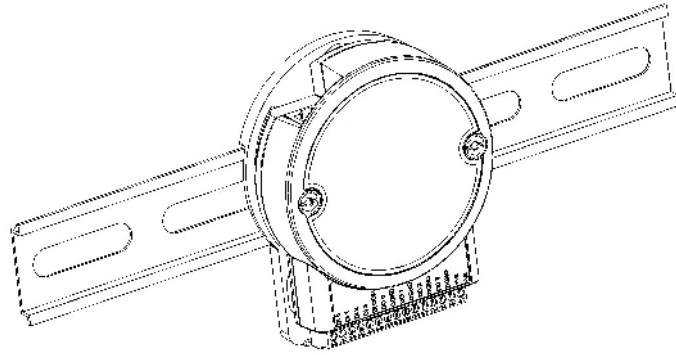

Figure 3.3 Mounting on the DIN-Rail

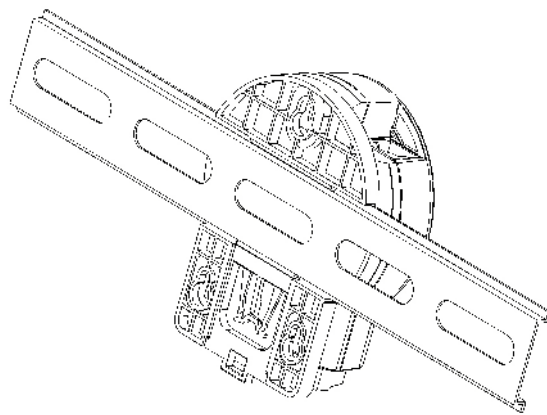

Figure 3.4 Rear View of DIN-Rail Mounting

3.2.2 Wall Mounting

Each WISE-4000 module is packed with a plastic wall mounting bracket. User can refer the bracket dimension and assembling figure to configure an optimal placement in a wall, panel, or cabinet.

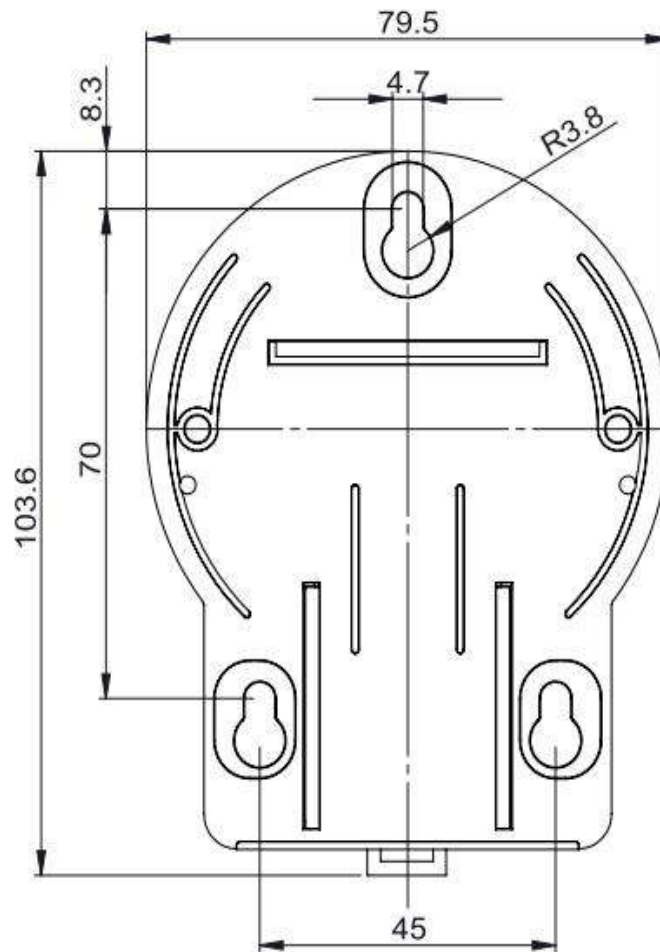

Figure 3.5 Mounting Kit Dimensions

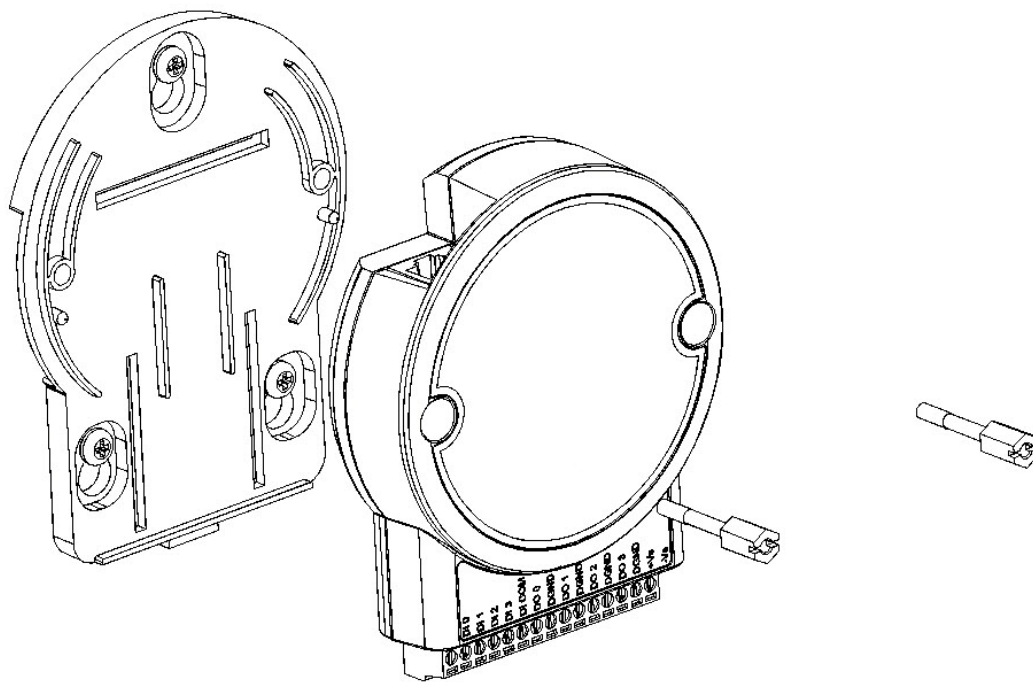

Figure 3.6 Wall Mounting

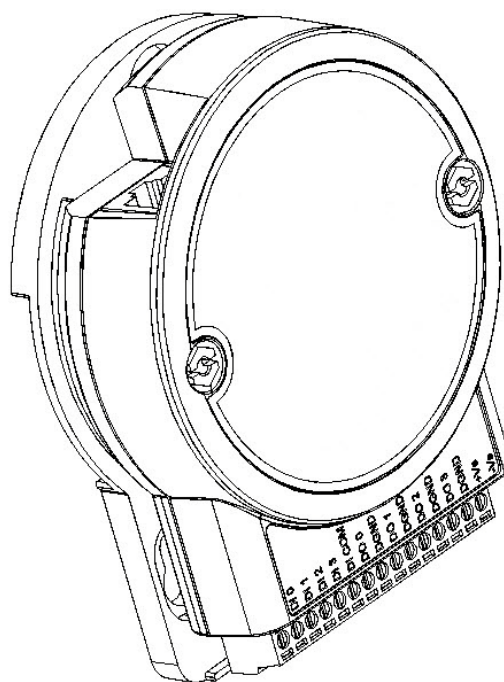

Figure 3.7 Wall Mounting Finished

3.2.3 Stack Mounting

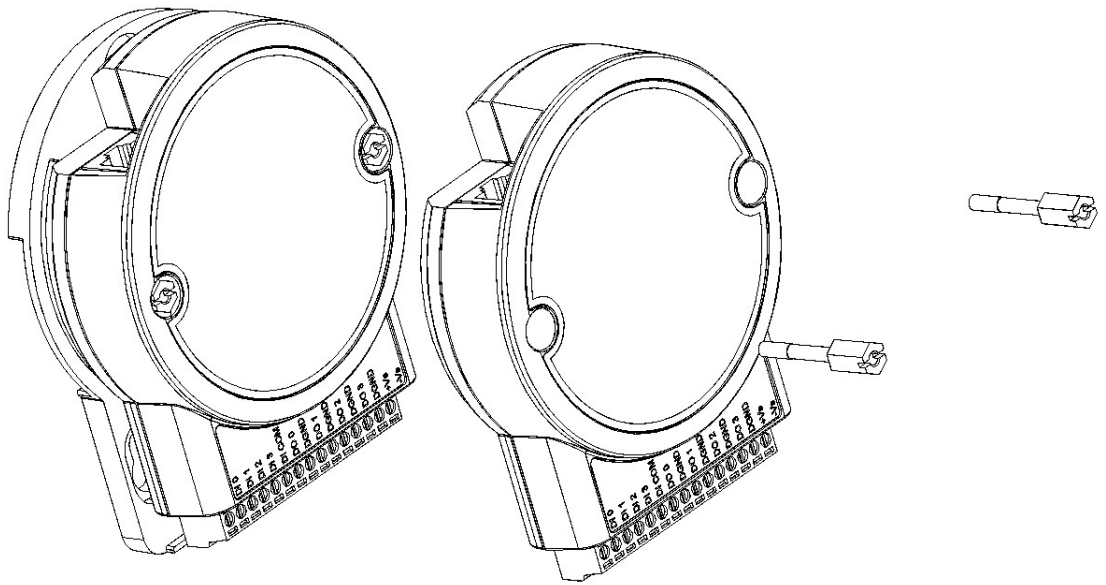

Figure 3.8 Stack Mounting

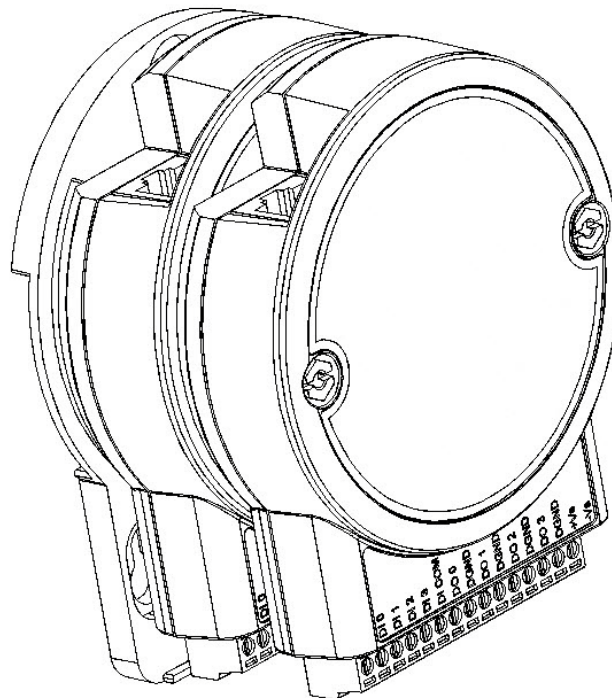

Figure 3.9 Finished Stack Mounting

3.3 Wiring & Connections

This section introduces basic information on wiring the power supply, I/O units, and Ethernet connection.

3.3.1 Power Supply Wiring (Not for WISE-4012E)

The system of WISE-4000 is designed for a standard industrial unregulated 24 V_{DC} power supply. For further application, it can also accept +10 to +30 V_{DC} of power input, 200mV peak to peak of power ripple, and the immediate ripple voltage should be maintained between +10 and +30 V_{DC}.

Screw terminals +Vs and -Vs are for power supply wiring

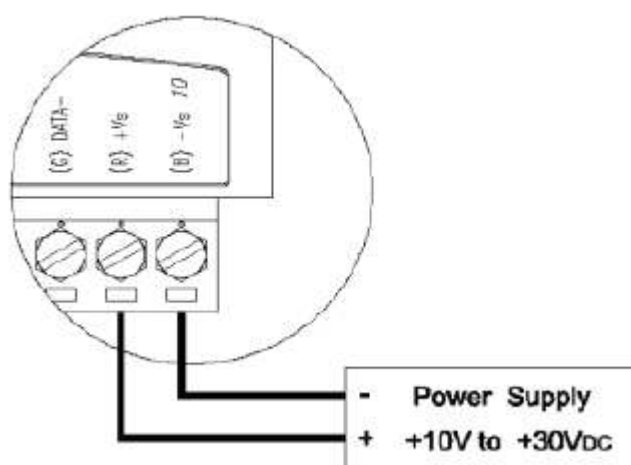

Figure 3.10 Power Supply Wiring

Note! The wires used should be at least 2 mm.



3.3.2 USB Power (WISE-4012E Only)

The system of WISE-4012E IoT Developer Kit is designed for a standard Micro-B USB 5V_{DC} power supply. Use the provided USB power cable to power up the module. Insert the Micro-B USB end to the USB port on the side of the module, and insert another end to Type-A 5V_{DC} USB port such as a PC, notebook, USB power adapter, USB power bank.

Note! The wider or flared part of the USB Micro-B connector is at the front side of the module, please make sure the direction of the cable before inserting it into the module to prevent the damage to the USB port.



Some USB power banks will automatically switch off, in this case, use a standard USB power instead.

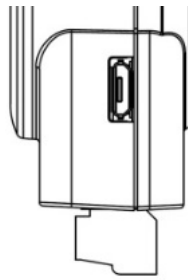

Figure 3.11 USB Power Supply Wiring

3.3.3 I/O Units

The system uses a plug-in screw terminal block for the interface between I/O modules and field devices. The following information must be considered when connecting electrical devices to I/O modules.

1. The terminal block accepts wires from 0.5 mm to 2.5 mm.
2. Always use a continuous length of wire. Do not combine wires.
3. Use the shortest possible wire length.
4. Use wire trays for routing where possible.
5. Avoid running wires near high-energy wiring.
6. Avoid running input wiring in close proximity to output wiring.
7. Avoid creating sharp bends in the wires.

Chapter 4

System Configuration

4.1 Connection

1. Plug a DC power source into the +Vs, -Vs pin of WISE module to turn the power on, or plug in the USB power cable for the WISE-4012E.
2. For WISE-4000/LAN Series, connect your computer to Ethernet port of WISE module with RJ-45 cross-over Ethernet cable, and configure the IP address of your computer as same IP domain as default IP address of module: 10.0.0.1. Or the wireless router can be used for configure the WISE-4000/LAN Series by mobile devices or computer with wireless adapter.
3. For WISE-4000 Wireless Series, the default operation mode in normal mode is AP Mode, or you can change position 1 of SW1 to OFF as in Section 1.5, to setting the module as Initial Mode, then module must be AP Mode. Now the module can be searched by mobile devices or wireless adapter of computer with SSID: WISE-4xxx_MACAddress. Click the SSID to connect the module in AP Mode, WISE module will auto assign the IP address for mobile devices or computer.



4.2 Configure WISE Using the Web Interface

4.2.1 System Requirements

WISE-4000 module is developed by public HTML 5 base, but for detailed indication and data transmission mode may be different on Web page of the operating system. For mobile devices, the minimum requirement of web browsers as below:

- Safari 6 in Apple iOS
- Web Browser in Google Android 4.0 (Ice Cream Sandwich)
- Chrome in Google Android 4.0 (Ice Cream Sandwich)

Mobile Browse	Chrome	Android	Safari
Configuration	Y	Y	Y
File Upload	N	N	N
Data Log Chart	Y	Y	Y
Data Log Export	N	N	N

For PC platforms, the minimum requirement of web browsers as below:

- Internet Explorer (version 11)
- Google Chrome (version 30)
- Mozilla Firefox (version 25)

Mobile Browse	Chrome	Firefox	Safari	IE11	IE10	IE9
Configuration	Y	Y	Y	Y	Y	Y
File Upload	Y	Y	N	Y	N	N
Data Log Chart	Y	Y	Y	Y	Y	N
Data Log Export	Y	Y	N	N	N	N

4.2.2 List of WISE-4000 Default Ethernet Ports

Application	Protocol	Port	Note
WebServer	TCP	80	Configurable
Modbus Server	TCP	502	-
Search Engine	UDP	5048	-
SNTP Client	UDP	-	Randomly

4.2.3 Factory Default Settings

WISE-4000/LAN Series

- Operation Mode: Normal Mode
- IP Mode: Static IP Address
- Default IP: 10.0.0.1
- Subnet Mask: 255.0.0.0
- Default Gateway: 0.0.0.0
- Default Connection Timeout: 720 second
- HTTP Port: 80

WISE-4000 Wireless Series

- Operation Mode: Normal Mode
- Wireless Mode: AP Mode
- IP Mode: Static IP Address
- Default IP: 192.168.1.1
- Subnet Mask: 255.255.255.0
- Default Gateway: 192.168.1.1
- DHCP Server: Enabled
- Default Connection Timeout: 720 second
- HTTP Port: 80

4.2.4 Module Authorization

Account	Default Password	Access Ability
root	00000000	All the privileges
admin	00000000	All the privileges except access control configuration
user	00000000	View module status only, not allow to do configuration

4.2.5 Operation Mode

The operation mode can be configured by switch SW1 on the back of module. Please refer to previous chapter for the detail of configuring SW1.

Mode	WISE-4000/LAN Series	WISE-4000 Wireless Series
Initial Mode	Fixed IP address: 10.0.0.1	Fixed IP address: 192.168.1.1 Fixed Wi-Fi Mode: AP Mode
Normal Mode	Default IP address: 10.0.0.1	Default IP address: 192.168.1.1 Default Wi-Fi Mode: AP Mode

4.2.6 Using a Browser to Configure the Module

- Configure URL: `http://IP_address/config`
- Default URL:
 WISE-4000/LAN Series: `http://10.0.0.1/config`
 WISE-4000 Wireless Series: `http://192.168.1.1/config`
- Configuration Steps

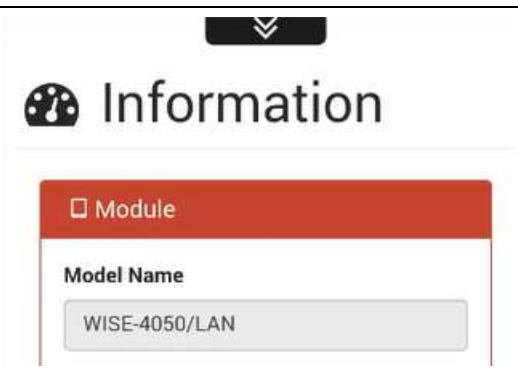
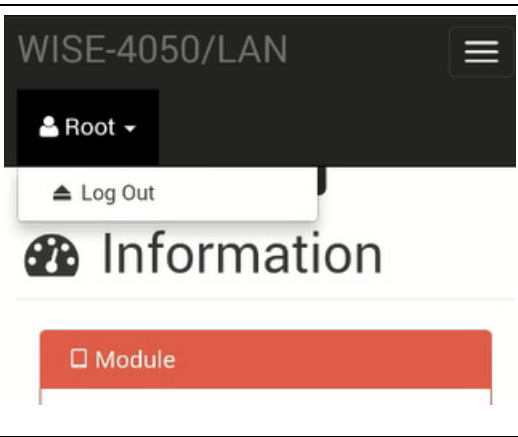
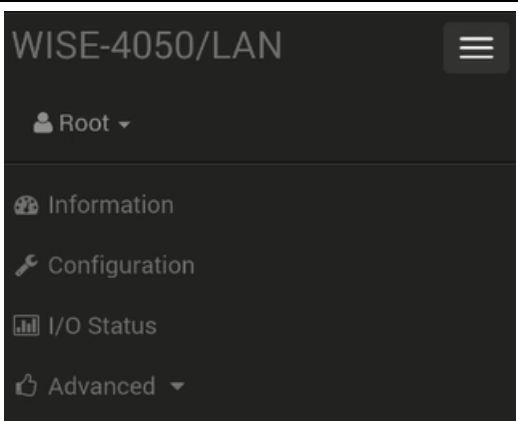
Login Web Configuration Page	
	<ol style="list-style-type: none"> 1. Wirelessly connect your smart phone to your local Ethernet network and open the browser of your smart phone. 2. Enter IP address of module with "/" config", for example, the default URL: <code>http://10.0.0.1/config</code> or <code>http://192.168.1.1/config</code> 3. Then you will see the login page, please enter the account and password, then click Login button
	<ol style="list-style-type: none"> 4. After login you will see the configuration web page
	<ol style="list-style-type: none"> 5. Scroll down the tab, you can change the login user here
	<ol style="list-style-type: none"> 6. Click the button on the top, you can switch to other pages

■ System Information

In the information page, you can see the dashboard: module detail, network setting, and module information, including the firmware version.

The screenshot shows a dashboard titled "Module" with a red header. It contains the following fields:

- Model Name:** WISE-4012
- Customized Name:** WISE-4012
- UUID:** WISE-4012_00D0C9CC00DF
- Location:** 4
- Description:** (Empty text area)
- Working Mode:** Normal Mode

At the bottom right, there is a "Go to Configuration" button with a red icon.

■ Module

Here you can see the naming of the module and related information. Click "Go to Configuration" to perform the configuration.

- **Model Name:** Indicates the WISE model
- **Customized Name / UUID:** Model name and UUID of the module, the default UUID is the combination of model name and the MAC address. It can be renamed.
- **Location Information:** You can note the location of the module
- **Description:** You can add comments on this module for easier recognition.
- **Working Mode:** Refer to 4.2.5 for Operation Mode

Module Information

Model Name	<input type="text" value="WISE-4012"/>	Customized Name	<input type="text" value="WISE-4012"/>
UUID	<input type="text" value="WISE-4012_00D0C9CC00DF"/>		
Description	<input type="text"/>		

Location Information

Latitude	<input type="text" value="1"/>	Longitude	<input type="text" value="2"/>
Altitude	<input type="text" value="3"/>		
Location	<input type="text" value="4"/>		

■ Wireless Status

For the WISE-4000 Wireless Series, users can check the WLAN RSSI Level to know the signal quality in Wireless Status field. And it also shows the MAC ID of the client device.

If the module is in AP Mode, the WLAN RSSI Level and Refresh button will not be shown.

Type	Status
WLAN RSSI Level	 Good
BSSID of the Access Point	B8-55-10-86-56-18

■ Network Information

For the WISE-4000 Wireless Series, WLAN Mode (AP Mode / Infrastructure) will be shown in Network Information. Here is an overview of the entire network configuration. To configure the network configuration, click “Go to Configuration”.

WLAN Mode: AP Mode
Mac: 00-D0-C9-CC-00-DF
IP: 192.168.1.1 Subnet: 255.255.255.0
Gateway: 192.168.1.1 IP Mode: Static DHCP

■ Module Information

Here you can check the model name and the module description of the module. The firmware version will also be shown here. At the end of the configuration web page, you can see the version of the configuration web page. For normal release module, the version of configuration web page will increase with the firmware version, these have been updated at the same time.

To update the firmware version, go the “Firmware Version” section.

Module Name	Module Description	Firmware Description
WISE-4012	2-channels digital output, 4-channels universal input	Fw:A0.91 B00, Bootloader:A0.90 B00

Version : A1.00 B05, Copyright © 2015 By Advantech Corp.

- Network Configuration
 - WLAN
 - ◆ AP Mode

When using the module in AP mode, users can configure the SSID and also decide how the WISE module works as an AP, including the security.

The “AP Mode IP Settings” is fixed and does not allow user to make their own changes.

WLAN Settings

WLAN Mode	<input type="text" value="AP Mode"/>		
SSID of the AP Mode	<input type="text" value="WISE-4012_CC00DF"/>		
SSID Hidden	<input type="checkbox"/> Enabled/Disabled		
Country Code	<input type="text" value="US"/>		
Operational Channel	<input type="text" value="11"/>		
Security Type	<input type="text" value="Security WPA/WPA2"/>		
Security Key	<input type="text" value="00000000"/>		

AP Mode IP Settings

Mac	<input type="text" value="00-D0-C9-CC-00-DF"/>		
IP	<input type="text" value="192.168.1.1"/>	Subnet Mask	<input type="text" value="255.255.255.0"/>
Gateway	<input type="text" value="192.168.1.1"/>	IP Mode	<input checked="" type="radio"/> Static <input type="radio"/> DHCP

- ◆ Infrastructure Mode

When using the module in “Infrastructure Mode”, users need to enter the SSID of the Access Point (AP) the WISE is going to access, and configure the security from here. WISE-4000 wireless modules provide a Second AP Setting, this is an optional setting for the WISE module to access another AP automatically. If you do not have a Second AP, you can leave the SSID blank.

After configuring the AP that the WISE module going to access, the IP address also needs to be defined in the Infrastructure-Network.

WLAN Settings

WLAN Mode	<input type="text" value="Infrastructure Mode"/>		
-----------	--	--	--

First AP Settings

SSID of the Access Point	<input type="text" value="Twifi"/>		
Security Type	<input type="text" value="Security Open"/>		

Secondary AP Settings (Optional)

SSID of the Access Point

Security Type

Infrastructure Mode IP Settings

Mac

IP Subnet Mask

Gateway IP Mode Static DHCP

– LAN

For WISE-4000/LAN wired module, you can select the Connection mode as DHCP or Static IP and configure the IP address, Subnet address, and Default gateway.

Network

Mac

IP Subnet

Gateway IP Mode Static DHCP

■ IO Status

– UI

For the **WISE-4012**, there are four universal input channels which can be configured as **Analog Input (AI)** or **Digital Input (DI)**. Before using the universal input channels, you need to configure the universal input channels to be AI or DI here.

UI Setting **AI** DI DO

Universal Input Channel Setting

- Use below configuration to set AI channel(s) as DI channel(s).
- Mode can not be changed when channel is in AI average mode.

Channel	Enable/Disable	Mode
0	<input checked="" type="checkbox"/>	AI
1	<input checked="" type="checkbox"/>	AI
2	<input checked="" type="checkbox"/>	DI
3	<input checked="" type="checkbox"/>	DI

– AI

For the AI channel, the Current/Max/Min status will be shown in the status page, which includes the input range. The current status shows the latest AI value, and also the input range. The average value, which will be introduced in following pages, show the average value of selected channels.

The Max/Min status shows historical maximum or minimum value, you can reset the value by pressing “Reset”.

DI Setting **AI** DI DO

Status Configuration Trend

Status

Current Max Min

Channel: 0

Range: +/- 10 V

Value: -0.0041 V

Low Alarm Status: Clear

High Alarm Status: Clear

Ch	Range	Value[Eg]	Value[Hex]	Value[Dec]
0	+/- 10 V	-0.0041 V	7FF2	32754
1	+/- 10 V	-0.0041 V	7FF2	32754

DI Setting **AI** DI DO

Status Configuration Trend

Status

Current Max Min

Channel: 0

Range: +/- 10 V

Value: 0.0090 V

Reset Value:

Ch	Range	Value[Eg]	Value[Hex]	Value[Dec]
0	+/- 10 V	0.0090 V	801D	32797
1	+/- 10 V	-0.0050 V	7FEF	32751

◆ Input Range

For the AI channel which supports more than input range, you can configure the channel setting in “AI/Configuration/Channel Settings”.

◆ Channel Mask

You can disable the AI channel to increase the sampling rate of other enabled channels in “Channel Mask”.

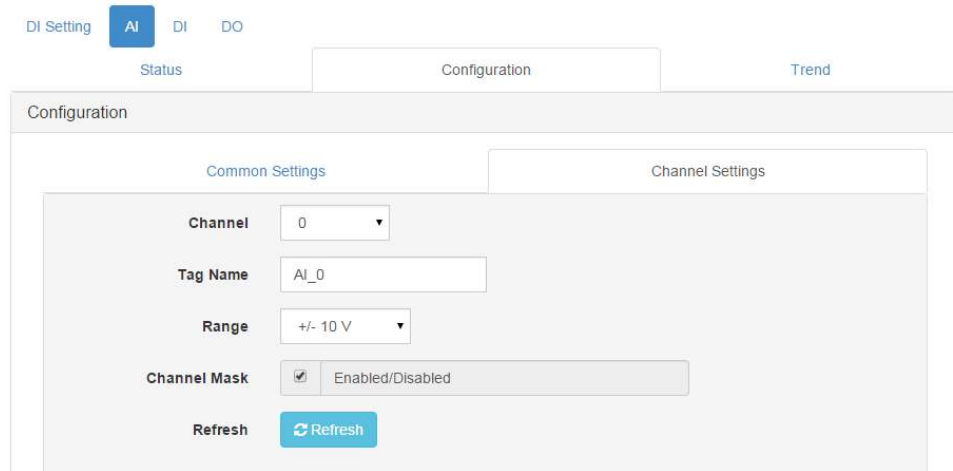

◆ Scaling Function

There are two types of scaling function for AI channels:

1. Input Signal Scaling - Scaling the Input Range

This is for scaling the analog input range within the configured input range, so that the Modbus value can fit the entire range. For example, Ch0 of WISE-4012 had been configured with an input range of 0~5V, but the full range of signal from sensors is 1~5V. If users do not use the Input Signal Scaling function, the 1V will be presented as 13107 in Modbus, 5V will be presented as 65535. But after Input Signal Scaling, 1V will be presented as 0 in Modbus, and 5V will still be presented as 65535.

If you would like to apply the function in the previous example, enter 1 in “Low Scaling Value”, and enter 5 in “High Scaling Value”.

Note!  The function only increases the resolution of Modbus data, but the accuracy still depends on the original input range before scaling. Furthermore, in the previous example, if the 0~10V input range been used for scaling to 1~5V, it may have a lower accuracy compared to using 0~5V.

For values which are going to be configured for scaling the input range, note that the “Low Scaling Value” should be lower than “High Scaling Value”.

2. Physical Value Scaling - Scaling the Output Data

Further to scaling the input range of the analog input channel, the output data can also be scaled. After the function has been applied, it would be easier to read the Modbus value in the engineering unit. For example, a temperature sensor output 0~10 V which shows 0~100°C. It would be better to read 0~100 in Modbus with floating data format.

In the previous case, you can configure the “Physical Min Scaling Value” and “Low Scaling Value” as 0, which shows the input voltage 0 V as physical value 0°C; and configure the “Physical Max Scaling Value” as 100 and “High Scaling Value” as 10, which shows the input voltage 10V as physical value 100°C.

Note!  The function is helping the data be more readable, but the accuracy still depends on the original input range before scaling and also depends on the sensor’s accuracy.

For the values which are going to be configured for scaling the output data. For users using RESTful Web API Mapping Unit, can be configured here for further use.

Low Scaling Value	<input type="text" value="0"/>	<input type="button" value="v"/>
High Scaling Value	<input type="text" value="0"/>	<input type="button" value="v"/>
Physical Min Scaling Value	<input type="text" value="0"/>	
Physical Max Scaling Value	<input type="text" value="0"/>	
Mapping Unit	<input type="text" value="0"/>	

◆ High/Low Alarm

For an AI module with digital or relay output functions featuring a built-in alarm function. When the analog input value is higher than the high alarm value, or lower than the low alarm value, an alarm condition occurs. Then the alarm status will be activated to logic high. The alarm status is shown in the status page of AI as alarm status LED display, when the alarm condition occurs, the Alarm status LED display will be lit.

The specified digital output channel will generate a logic high value if you build the mapping relationship between alarms and DO channel in the DO mapping area. You can map the DO channel referring to AI Alarm section of DO configuration. The High/Low Alarm status LED in AI status page can be cleared by clicking “Clear”.

This page is for enabling and configuring the alarm. There are two alarm modes:

1. **Latch:** Once the alarm occurs, the alarm status will be activated to logic high level and will keep the value until the alarm is manually cleared. Before the value is cleared, the Alarm status LED will be continuously lit. For an AI module with digital or relay output functions, the specific output channel (chosen in the DO AI Alarm configuration page) will continuously generate logic high value. You can clear the alarm by clicking the “Clear” button in the AI status page.
2. **Momentary:** The alarm status will dynamically change depending on the alarm condition. If the alarm occurs, the alarm status will be logic high. If the alarm condition disappears, the alarm status will be logic low. So not only will the Alarm status LED be lit, in the web page the specific digital output channel value will change depending on the alarm condition.

After you choose the alarm mode for high alarm or low alarm, you can define the high alarm value or low alarm value by entering the value in Alarm limit text box.

Enable Low Alarm	<input checked="" type="checkbox"/> Enabled/Disabled
Low Alarm Mode	<input type="text" value="Momentary"/>
Low Alarm Value	<input type="text" value="0"/>
Enable High Alarm	<input checked="" type="checkbox"/> Enabled/Disabled
High Alarm Mode	<input type="text" value="Latch"/>
High Alarm Value	<input type="text" value="0"/>

◆ Burnout Detection

The Burnout Detection function, or open-wired function, is designed for 4~20mA input range or temperature input range. For the WISE-4012, the burnout signal is activated when the current is less than 3mA. The Modbus flag indicates that the wire of the sensor connected to the channel has burned out. You can also check the Modbus address of AI Channel Status for detail.

When a burnout situation had been detected, the AI value can be shown in “Up scale” which is FFFF(HEX), or “Down scale” which is 0. You can configure this in “Burnout Detection Mode”.

◆ Sampling Rate

For models which support more than one sampling rate, you can configure the sampling rate here. For low sampling rate mode, the AI channel would have better noise rejection ability. For the high sampling rate mode, the noise will allow easier coupling to the signal.

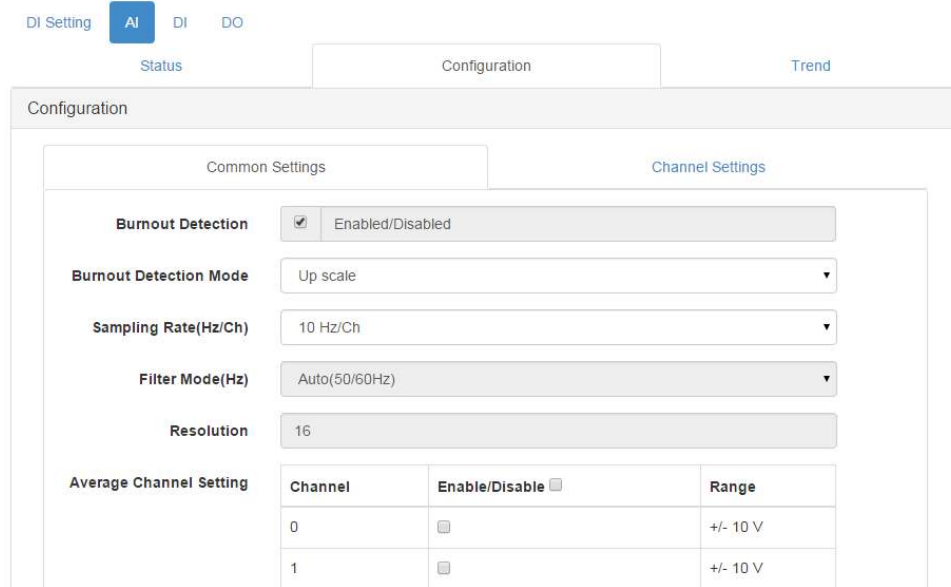

◆ Average Channel Setting

To reduce the data amount, some users don't need the detailed value of each channel but the average value of the selected channel. When the channel is enabled, the values will be averaged in 16-bit integer data, and can be shown or read as another channel.

◆ Calibration

WISE analog input modules support internal reference calibration function, before using the calibration function, you can also try to reset the module to the default factory settings for troubleshooting, or if the calibration process had not succeeded, you can reset the module to the default factory calibration parameters.

Click “**Calibration**” and follow the instructions to calibrate the AI channels.

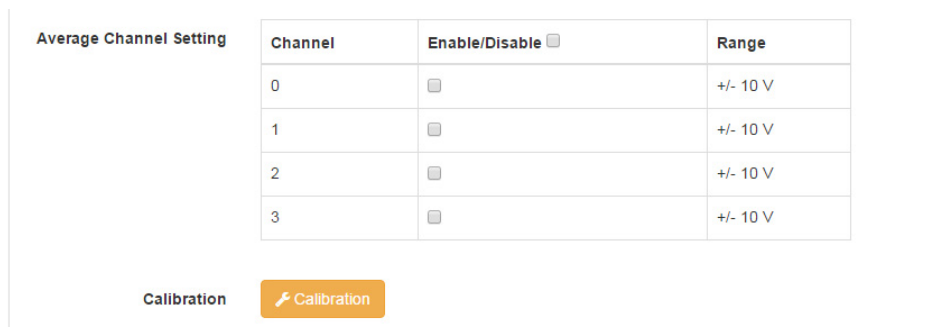

◆ AI Trend

Here you can instantly check the analog input trend of each channel. The function is useful when testing the connection and variety between WISE and sensors.



– DI

You can see the value of all digital input channels by the related LED display in this page. When DI status is a logical high, the LED will be green. If the status is a logical low, the LED will be grey.

The screenshot displays the 'DI' status section of the control system interface. At the top, there are tabs for 'DI Setting', 'AI', 'DI', and 'DO', with 'DI' selected. Below these are sub-tabs for 'Status', 'Configuration', and 'Trend'. The main area is titled 'Status' and contains a table with the following data:

Channel	Mode	Status
0	DI	
1	DI	

◆ Invert Signal

WISE digital input channels support Invert DI Status function, there will be an **Invert Signal** check box in the configuration page. Click the check box to enable/disable the function.

◆ Digital Filter

Digital input channels support digital filters, these can be enabled or disabled by clicking the **Digital Filter** check box. If you enable the filter, you can define the minimum acceptable signal width by the **Min. Low Signal Width** and **Min. High Signal Width** text box. (Unit: 0.1ms) The high frequency noise will be removed by this filter.

The screenshot shows the 'Configuration' page for a Digital Input (DI) channel. At the top, there are tabs for 'DI Setting', 'AI', 'DI' (selected), and 'DO'. Below these are 'Status', 'Configuration', and 'Trend' sub-tabs. The 'Configuration' section contains the following fields:

- Channel:** A dropdown menu set to '0'.
- Tag Name:** A text box containing 'DI_0'.
- Mode:** A dropdown menu set to 'DI'. A warning icon and text state: 'All data will be cleared in the data logger if Channel Mode is changed.'
- Refresh:** A blue button with a refresh icon and the text 'Refresh'.
- Invert Signal:** A checkbox that is unchecked, with a label 'Enabled/Disabled'.
- Digital Filter:** A checkbox that is unchecked, with a label 'Enabled/Disabled'.
- Min. Low Signal Width:** A text box with '1' and a unit selector set to '0.1ms'.
- Min. High Signal Width:** A text box with '1' and a unit selector set to '0.1ms'.

◆ Counter Mode

When you choose Counter mode, one counter will count the pulse number of the digital signal from the selected channel, and then record the count number in the register. In the DI Status page, the current count value of the selected channel is displayed by the Counter value text box. Start or stop the counter by switching the **Start/Stop** switch next to the Counter value. Reset the counter (the value in the register will be initialized to the startup value, default to be zero) by clicking the **Reset** button. Preset the **Startup Value** in the text box. When you reset the counter value, either by the reset button in the status page or by a command, the value will be reset to the Startup Value. The default value of the **Startup Value** is zero.

Like the DI mode, you can enable/disable the **Invert Signal** function and **Digital Filter** in the configuration page. The operation is the same. If you enable **Keep Last Value**, when the digital module been powered off, the last counter value will be kept in the register. When the module powers on, the counter will continuously count from that value. Without this function, when the module powers off, the counter will reset and the count value in the register will be zero.

The screenshot shows the configuration page for Counter Mode. It includes the following fields:

- Invert Signal:** A checkbox that is unchecked, with a label 'Enabled/Disabled'.
- Digital Filter:** A checkbox that is unchecked, with a label 'Enabled/Disabled'.
- Min. Low Signal Width:** A text box with '1' and a unit selector set to '0.1ms'.
- Min. High Signal Width:** A text box with '1' and a unit selector set to '0.1ms'.
- Startup Value:** A text box with '0' and a unit selector set to 'times'.
- Keep Last Value:** A checkbox that is unchecked, with a label 'Enabled/Disabled'.

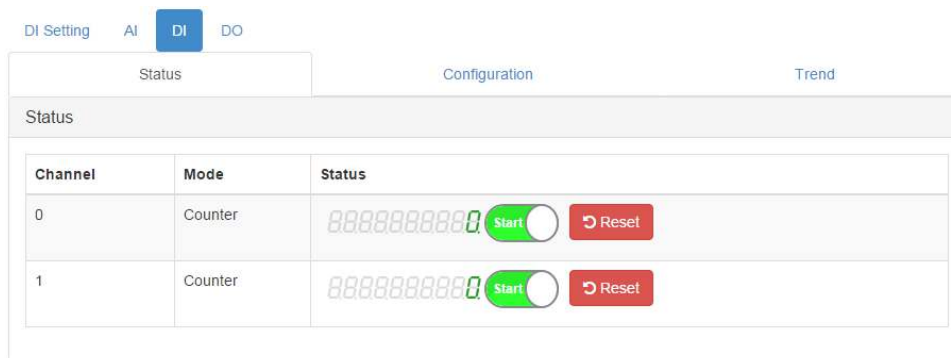

◆ Low to High Latch

When you choose **Low to High Latch** mode, once the digital input channel detects logic level changes from low to high, the logic status will be kept as logic high. The logic status will remain the logic high, until you clear the latch manually. The logic status will return to logic low. The logic status can be seen by the Latch status LED display in the DI Status page. Clear the latch by clicking the **Clear** button. Enable/disable the **Invert Status** function in the configuration page.

◆ High to Low Latch

When you choose **High to Low Latch** mode, once the digital input channel detects logic level changes from high to low, the logic status will be kept as high. The logic status will remain high, until you clear latch manually. Then the logic status will return to low. The logic status can be seen by the Latch status LED display in the DI Status page. Clear the latch by clicking the **Clear** button. Enable/disable the **Invert Status** function in the configuration page.

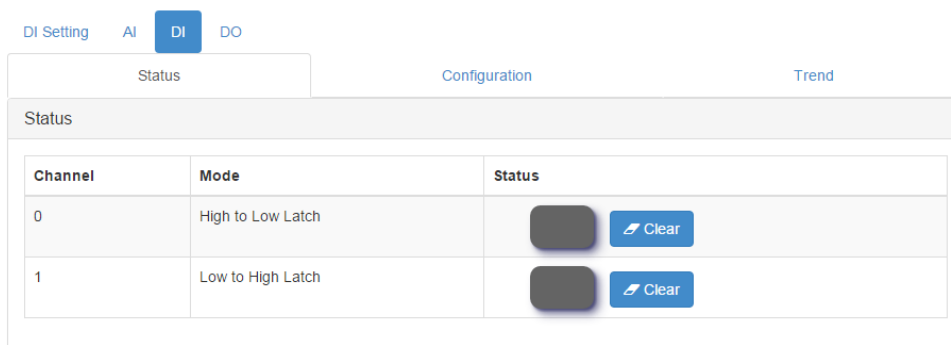

◆ Frequency

For pure DI channels, not including the DI function of the WISE-4012, WISE modules support frequency mode. WISE module will calculate the frequency value of the digital input signal from the selected channel. The frequency value will be displayed in the Frequency value text box in the DI Status page.

– DO

You also can control the values of all digital output channels by the status switch. The color of the switches will display current value of that digital output channel.

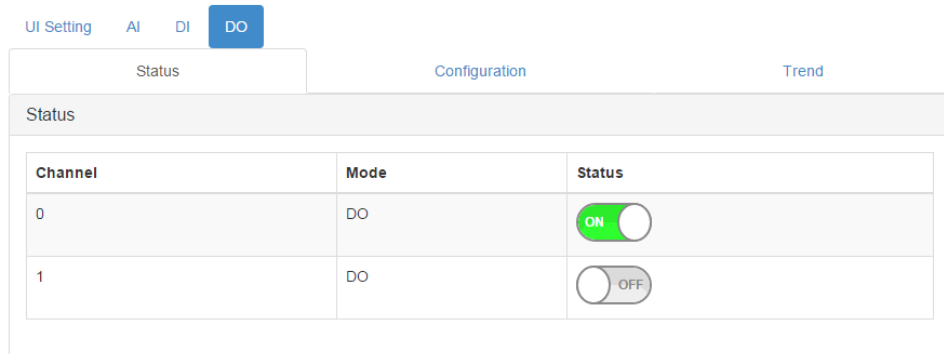

◆ Fail Safe Value (FSV)

When the communication between the host controller and WISE digital modules is broken, the digital output channel can generate a predefined value (this value is called the fail safe value). If the FSV checkbox is checked, the module will set the output channel to logic high when WDT times-out. If the FSV checkbox is unchecked, the module will set the output channel to logic low when WDT times-out.

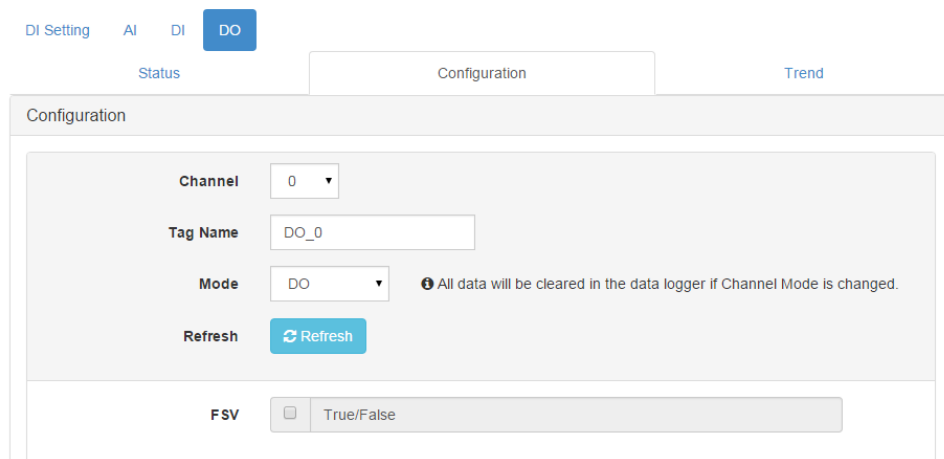

To decide whether to enable the FSV function triggered by communication with the WDT, go to **General Configuration** and enable the FSV function for all the module's output channels.

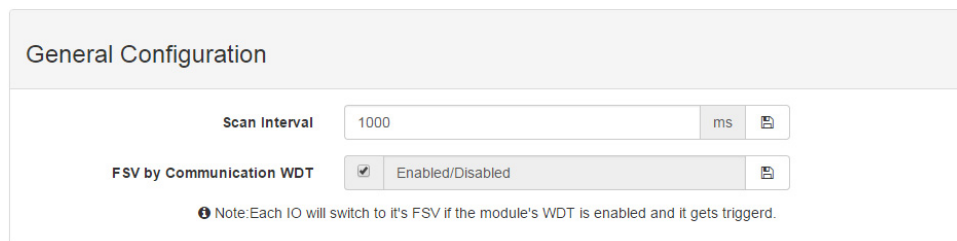

To decide the time period to trigger the communication WDT, go to **Network Application** to enable the **Communication WDT Mode** as **Communication WDT** first, and then configure the **Host Idle (Timeout)**. (Unit: second) The default host idle time is 720 seconds.

Network Application

Web Server Port (Default:80) 80

Hostidle (Timeout) 720 sec

Communication WDT Mode Communication WDT

Submit

◆Pulse Output

After you choose the **Pulse Output** mode, the selected digital output channel can generate continuous pulse train or finite pulses. You can define the pulse width by entering into the **Low Signal Width** and **High Signal Width** text box in the configuration page. (Unit: 0.1 ms) The frequency and duty cycle of the pulse output signal will be calculated automatically and displayed by the **Output frequency** and **Duty cycle** text box.

Then choose whether to generate a continuous pulse train or finite pulses by selecting the **Continuous** (for pulse train) or the **Fixed total** (for finite pulses). The text box on the right of the **Fixed total** button is used to define how many pulses you want to generate. After selecting pulse output mode, click the **Start** or **Stop** button to generate or to stop the pulse output.

FSV True/False

Low Signal Width 1 0.1ms

High Signal Width 1 0.1ms

Output frequency 5000 HZ

Duty cycle 50 %

DI Setting AI DI DO

Status Configuration Trend

Status

Channel	Mode	Status
0	Pulse Output	<input type="radio"/> Continue <input checked="" type="radio"/> Fixed total 0 ▶ Start ■ Stop
1	AI Alarm Drived	<input checked="" type="checkbox"/> ON

◆ Low to High Delay

Choosing **Low to High Delay** mode, is almost the same as choosing DO mode. The only difference is that there will be certain time delays when the output value changes from logic low to logic high. Define the delay time by entering its value into the **Delay Time** text box in the configuration page. Control the digital output value using the DO button and seeing its current value by the DO status LED display in the DO Status page.

◆ High to Low Delay

Choosing **High to Low Delay** mode, is almost the same as choosing DO mode. The only difference is that there will be certain time delay when the output value changes from logic high to logic low. Define the delay time by entering its value into the **Delay Time** text box in the configuration page. Control the digital output value using the DO button and seeing its current value by the DO status LED display in the DO Status page.

FSV True/False

Delay Time 0.1ms

DI Setting AI DI DO

Status Configuration Trend

Channel	Mode	Status
0	Low to High Delay	<input type="checkbox"/> OFF
1	High to Low Delay	<input type="checkbox"/> OFF

◆ AI Alarm Driven

After the **High/Low Alarm** been configured in AI channel configuration, the alarm status can be mapped in to DO channel. Choose the **High Alarm** or **Low Alarm** in **Trigger Mode** to active the configured DO channel.

Mapping Channel

Trigger Mode

4.2.7 Configuring the RS-485 Port of WISE-4051

WISE-4051 has one RS-485 port for Modbus gateway function, thus you can use this port to polling the data from RS-485 Modbus/RTU slave devices, like ADAM-4000, or ADAM-5000/485.

4.2.7.1 External Coils or Registers Status of RS-485 Port

Go the "COM1" tab to check the status or configure the Modbus Master function of RS-485 port. There can be total 32 addresses of all Modbus slave to be mapped as the I/O of WISE-4051. These 32 addresses can be coils or registers. The coils will be mapped as extension bits of WISE-4051, and the registers will be mapped as extension words of WISE-4051. So in the "Status" tab, you can see the bits or words are shown in individual pages.

Column "Channel" indicate the number of bits, there are maximum 32 bits can be shown here, but you may only mapping less than 32 coils as bits, so the empty bits are invalid. Same as words may also have empty channels.

Column "Value" shows the value polling from mapped address.

Column "Status" shows the status of each bits or words, if the channel is empty which did not be mapped to Modbus slave address, the status will shows "Unavailable".

Column "Slave ID" and "Slave Address" show where the bit or word from RS-485 Modbus slave device.

Column "Mapping Address" shows the Modbus address of bits or words when WISE-4051 be polled by Modbus/TCP. The default setting of extension bits is from Modbus address 01001 of WISE-4051, and extension words is from Modbus address 41001 of WISE-4051. There are 32 address reserved for extension bits or words for WISE-4051.

DI **COM1**

Status Modbus/RTU Configuration Diagnostician

Status

Bit Status Word Status

Show 16 entries [Edit](#)

Channel	Value	Status	Slave ID	Slave Address	Mapping Address(0X)
0	0	Slave response timeout	2	1	1001
1	0	Slave response timeout	2	2	1002
2	0	Slave response timeout	2	3	1003
3	0	Slave response timeout	2	4	1004
4	0	Slave response timeout	2	5	1005
5	0	Slave response timeout	2	6	1006
6	0	Slave response timeout	2	7	1007
7	0	Slave response timeout	2	8	1008

DI COM1

Status Modbus/RTU Configuration Diagnostician

Status

Bit Status Word Status

Show 16 entries Edit

Channel	Value	Status	Slave ID	Slave Address	Mapping Address(4X)
0	0	Slave response timeout	1	1	1001
1	0	Slave response timeout	1	2	1002
2	0	Slave response timeout	1	3	1003
3	0	Slave response timeout	1	4	1004
4	0	Slave response timeout	1	5	1005
5	0	Slave response timeout	1	6	1006
6	0	Slave response timeout	1	7	1007
7	0	Slave response timeout	1	8	1008

For the writable bit or word, you can click "Edit" button to switch to edit mode, change value and click "Apply" to write the Modbus address individually.

Bit Status Word Status

Show 16 entries View

Channel	Value	Status	Slave ID	Slave Address	Mapping Address(0X)	
0	<input type="radio"/> 0 <input type="radio"/> 1	Slave response timeout	2	1	1001	Apply
1	<input type="radio"/> 0 <input type="radio"/> 1	Slave response timeout	2	2	1002	Apply
2	<input type="radio"/> 0 <input type="radio"/> 1	Slave response timeout	2	3	1003	Apply
3	<input type="radio"/> 0 <input type="radio"/> 1	Slave response timeout	2	4	1004	Apply
4	<input type="radio"/> 0 <input type="radio"/> 1	Slave response timeout	2	5	1005	Apply
5	<input type="radio"/> 0 <input type="radio"/> 1	Slave response timeout	2	6	1006	Apply
6	<input type="radio"/> 0 <input type="radio"/> 1	Slave response timeout	2	7	1007	Apply
7	<input type="radio"/> 0 <input type="radio"/> 1	Slave response timeout	2	8	1008	Apply

Bit Status Word Status

Show 16 entries View

Channel	Value	Status	Slave ID	Slave Address	Mapping Address(4X)	
0	<input type="text" value="0"/>	Slave response timeout	1	1	1001	Apply
1	<input type="text" value="0"/>	Slave response timeout	1	2	1002	Apply
2	<input type="text" value="0"/>	Slave response timeout	1	3	1003	Apply
3	<input type="text" value="0"/>	Slave response timeout	1	4	1004	Apply
4	<input type="text" value="0"/>	Slave response timeout	1	5	1005	Apply
5	<input type="text" value="0"/>	Slave response timeout	1	6	1006	Apply
6	<input type="text" value="0"/>	Slave response timeout	1	7	1007	Apply
7	<input type="text" value="0"/>	Slave response timeout	1	8	1008	Apply

4.2.7.2 Modbus/RTU Configuration of RS-485 Port

In the "Common Setting" Tab, you can configure the parameters of WISE-4051 RS-485 port

- Baud Rate: 1200, 2400, 4800, 9600, 19200, 38400, 57600, 115200 bps
- Data Bit: 7, 8
- Stop Bit: 1, 2
- Parity: None, Odd, Even
- Slave Respond Timeout: Here you can configure the time for waiting Modbus slave reply

- **Delay between Polls:** Here you can configure the delay time between each Modbus instructions
- **CRC Check:** Here you can enable/disable the CRC check/ignore the CRC error of Modbus

The screenshot displays the 'Modbus/RTU Configuration' page. At the top, there are tabs for 'Status', 'Modbus/RTU Configuration', and 'Diagnostician'. The 'Modbus/RTU Configuration' tab is active, showing two sub-tabs: 'Common Setting' and 'Rule Setting'. The 'Common Setting' sub-tab is selected, containing the following fields:

- Baud rate:** 9600 bps
- Data Bit:** 8 bit
- Parity:** None
- Stop Bit:** 1 bit
- Slave response timeout:** 50 ms
- Delay between Polls:** 10 ms
- CRC Check:** Disable Enable

A green 'Submit' button is located at the bottom right of the configuration area.

In the "**Rule Setting**" tab, you can configure this Modbus address of end devices you would like to polling.

- **Rule:** There are maximum 8 rules that WISE-4051 support. Each rules can be different slave devices, in the other word, it can be maximum 8 devices connected to WISE-4051. Or you can use all rules for polling different address of same slave device.
- **Slave ID:** Different slave devices in same RS-485 has different slave ID, enter the slave address of Modbus devices which connected to WISE-4051 here
- **Type:** We support 4 kinds of Modbus data type, 01 Coil Status (0x), 02 Input Status (1x), 03 Holding Registers (4x), and 04 Input Registers (3x). After you configure one of the types in the rule, then this rule will be enabled, and WISE-4051 will start to polling after the configuration been submitted successfully.
- **Start Address:** Enter the first address number that you are going to polling. The address base is 1, if you are going to polling the first address of Holding Registers, 40001, please enter number 1 here. Don't need to enter the whole address 40001.
- **Length:** Enter the length of the address that you are going to polling in this rule. For example, if you are going to polling 40001~40008, enter the length as 8 here. Please be noted that since WISE-4051 can polling maximum 32 address, the maximum length is 32 addresses, and the total amount of all rules should also less or equal to 32.
- **R/W:** Here you can decide if the address in this rule will be Read or Written or not. For Coil Status and Holding Registers, you can make these addresses read only, or write only to reduce the polling effort.
- **Scan Interval (in milliseconds):** Here decide the scan interval for WISE-4051 to polling Modbus slave devices. WISE-4051 will optimize the scan interval according you setting. However, the read scan interval may also depend on real case like: Baud rate, slave devices respond time, delay time between polls, etc. Go to the Diagnostician page to check the real respond time for referring the value of scan interval.
- **Mapping Channel:** When the Modbus address of slave devices been configured in each rule, these addresses will also be mapped into WISE-4051. Coils of Modbus slave devices will be mapped as bits for RESTful web service and

also be mapped as coils for Modbus address of WISE-4051. Registers of Modbus slave devices will be mapped as words for RESTful web service and also be mapped as registers for Modbus address of WISE-4051. There are 32 continuous channels of bit and another 32 continuous channels of word can be mapped. Please make sure the channels for each rules are not overlapped.

- **Log:** Here you can decide the data been polled from this rule will be logged in data logger or not.
- **Rule Status:** The web configuration interface will check if rule settings have any overlapping or confliction. The enabled rules (enable the rule by configuring “Type”) should have green icon so that the “Submit” will be shown for submitting the rules.

Note! After configuring the rules, click “Submit” to apply the rules.



Note! After changing the rule configurations, the logged data in data logger will be cleared for organizing new data structure of data logger for new configurations.



Note! Place your mouse over the table title to show the tips.



Modbus/RTU Configuration									
Common Setting					Rule Setting				
Rule	Slave ID	Type	Start Address	Length	R/W	Scan Interval	Mapping Channel	Log	Rule Status
0	1	03 Holding register	1	8	R	1000	0	<input checked="" type="checkbox"/>	✔
1	2	01 Coil status	1	8	R	1000	0	<input checked="" type="checkbox"/>	✔
2	2	01 Coil status	17	8	R	1000	8	<input checked="" type="checkbox"/>	✔
3	0	Disable	1	1	R	1000	0	<input type="checkbox"/>	✘
4	0	Disable	1	1	R	1000	0	<input type="checkbox"/>	✘
5	0	Disable	1	1	R	1000	0	<input type="checkbox"/>	✘
6	0	Disable	1	1	R	1000	0	<input type="checkbox"/>	✘
7	0	Disable	1	1	R	1000	0	<input type="checkbox"/>	✘

● Total 32 coils or registers can be configured.
 ● All data in data logger will be cleared if rule is changed.
 ● Mouse over table title to show tip.

In previous figure we demonstrate how to configure an ADAM-4017+ (or ADAM-4117) which slave ID is 1 and an ADAM-4055 which slave ID is 2 as the Modbus slave devices connected to WISE-4051.

ADAM-4017+ (or ADAM-4117) is an 8-ch analog input Modbus I/O modules, the Modbus address of AI0~AI7 are 40001~40008. In the **Rule Setting** page, we configure the **Slave ID** = 1; **Type** = 03 Holding Registers, since the Modbus address 40001 is start from 4; **Start Address** = 1 and **Length** = 8 for the address 40001~40008; **R/W** = R, since this address is for analog input which is read only; **Scan Interval** = 1000ms for polling every second; **Mapping Channel** = 0, to mapping the data from AI0~7 of ADAM-4017+ to channel 0~7 of Word Status; and check the **Log** to log the data from ADAM-4017+.

ADAM-4055 is an 8-ch digital input and 8-ch digital output Modbus I/O modules, the Modbus address of DI0~DI7 are 00001~00008; the Modbus address of DO0~DO7 are 00017~00024. Since the address is not continuously, so we are going to configure digital input as one rule, and digital output as another rule.

For digital input channels: In the **Rule Setting** page, we configure the **Slave ID** = 2; **Type** = 01 Coil Status, since the Modbus address 00001 is start from 0; **Start Address** = 1 and **Length** = 8 for the address 00001~00008; **R/W** = R, since this address is for digital input which is read only; **Scan Interval** = 1000ms for polling every second; **Mapping Channel** = 0, to mapping the data from DI0~7 of ADAM-4055 to channel 0~7 of Bit Status; and check the **Log** to log the data from ADAM-4055. Please be noted that the Bit Status and Word Status have individual channel number, so the Word Status for ADAM-4017+ and the Bit Status for ADAM-4055 are all start from 0.

For digital output channels: In the **Rule Setting** page, we configure the **Slave ID** = 2; **Type** = 01 Coil Status, since the Modbus address 00017 is start from 0; **Start Address** = 17 and **Length** = 8 for the address 00017~00024; **R/W** = R/W, since this address is for digital output which can be wrote and read, you can also configured as W if you don't want to read back the value; **Scan Interval** = 1000ms for polling every second; **Mapping Channel** = 8, to mapping the data from DO0~7 of ADAM-4055 to channel 8~15 of Bit Status; and check the **Log** to log the data from ADAM-4055. Please be noted that the channel 0~7 of Bit Status have been occupied by previous rule, so you should assign the channel number from channel 8~31.

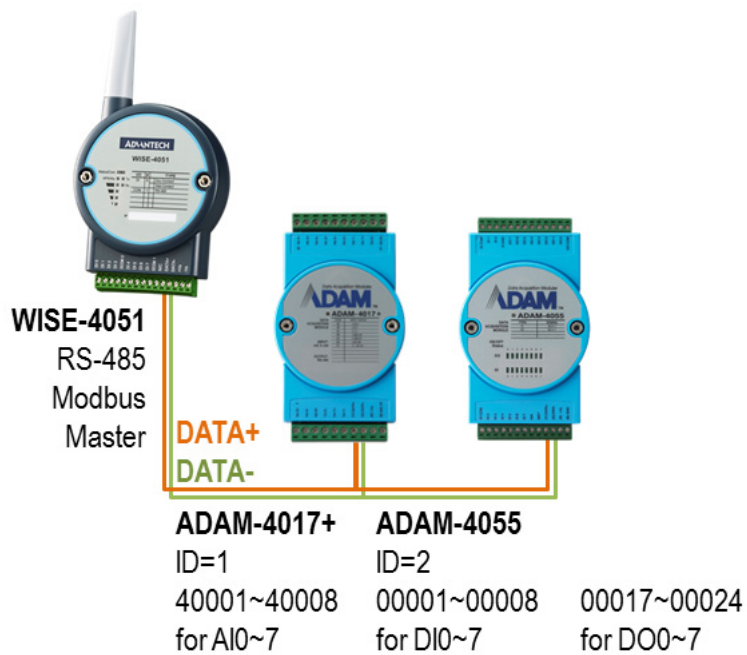

Figure 4.1 Application Scenario of WISE-4051 RS-485 Port with ADAM-4000 Modbus I/O Module

Table 4.1: Application Scenario of WISE-4051 RS-485 Port with ADAM-4000 Modbus I/O Module

WISE-4051		ADAM-4055		WISE-4051		ADAM-4017+	
Bit Status	Mapped Modbus Address	I/O	Slave Modbus Address	Word Status	Mapped Modbus Address	I/O	Slave Modbus Address
Ch0	01001	DI0	00001	Ch0	41001	AI0	40001
Ch1	01002	DI1	00002	Ch1	41002	AI1	40002
Ch2	01003	DI2	00003	Ch2	41003	AI2	40003
Ch3	01004	DI3	00004	Ch3	41004	AI3	40004
Ch4	01005	DI4	00005	Ch4	41005	AI4	40005
Ch5	01006	DI5	00006	Ch5	41006	AI5	40006
Ch6	01007	DI6	00007	Ch6	41007	AI6	40007
Ch7	01008	DI7	00008	Ch7	41008	AI7	40008
Ch8	01009	DO0	00017	Ch8	41009		
Ch9	01010	DO1	00018	Ch9	41010		
Ch10	01011	DO2	00019	Ch10	41011		
Ch11	01012	DO3	00020	Ch11	41012		
Ch12	01013	DO4	00021	Ch12	41013		
Ch13	01014	DO5	00022	Ch13	41014		
Ch14	01015	DO6	00023	Ch14	41015		
Ch15	01016	DO7	00024	Ch15	41016		
Ch16	01017			Ch16	41017		
Ch17	01018			Ch17	41018		
Ch18	01019			Ch18	41019		
Ch19	01020			Ch19	41020		
Ch20	01021			Ch20	41021		
Ch21	01022			Ch21	41022		
Ch22	01023			Ch22	41023		
Ch23	01024			Ch23	41024		
Ch24	01025			Ch24	41025		
Ch25	01026			Ch25	41026		
Ch26	01027			Ch26	41027		
Ch27	01028			Ch27	41028		
Ch28	01029			Ch28	41029		
Ch29	01030			Ch29	41030		
Ch30	01031			Ch30	41031		
Ch31	01032			Ch31	41032		

4.2.7.3 Modbus Slave Devices Diagnostician

Since different devices will have different responds time, to have better configuration of scan interval, here WISE-4051 provides Diagnostician function for testing the respond time of each rule. You can refer to the respond timeout in this page for configuring the “**Scan Interval**” in “**Rule Setting**” page. You can reset the testing result in this page by clicking “**Reset Response Time**”.

The screenshot shows the 'Diagnostician' tab in the software interface. It displays a table titled 'Modbus/RTU Slave Response Time' with the following data:

Rule	Current Response Time(ms)	Max Response Time(ms)	Min Response Time(ms)	Status
0	50	50	50	Slave response timeout
1	50	50	50	Slave response timeout
2	50	50	50	Slave response timeout
3	0	0	65535	Unavailable
4	0	0	65535	Unavailable
5	0	0	65535	Unavailable
6	0	0	65535	Unavailable
7	0	0	65535	Unavailable

Below the table, it indicates 'Polling: 16 times...' and a green button labeled 'Reset Response Time'.

- Scan Interval of IO status

Scan Interval decides the I/O polling interval in the next part of the “I/O Status”. This value will not be saved into the module, so it is only valid until the power is switched off.

The screenshot shows the 'General Configuration' page. It features two main settings:

- Scan Interval:** A text input field containing '1000' with a unit dropdown set to 'ms'.
- FSV by Communication WDT:** A checkbox that is checked, with a dropdown menu showing 'Enabled/Disabled'.

A note below the settings states: "Note: Each IO will switch to it's FSV if the module's WDT is enabled and it gets triggered."

■ System Control and Maintenance

- Locate module - Helps user search for lit modules. (The status LED will be on for 30 seconds when enabled.)
- Restore to factory default -The system configuration will be cleared and restored to factory default settings when enabled.
- Reset password- Reset the password here
- Restart system -This module’s system will reboot when enabled.

The screenshot shows the 'Control' page with four main actions:

- Locate:** A button with a wrench icon, currently set to 'Disabled', and a power icon.
- Restore to Default:** A button with a wrench icon, set to 'Restore', and a trash icon.
- Reset Password:** A button with a wrench icon, set to 'Reset', and a document icon.
- System Restart:** A button with a wrench icon, set to 'Restart', and a power icon.

- Diagnostician

WISE modules provide a Diagnostician page for indicating the operating status of the WISE module. The status of each function is shown for easy troubleshooting.

Diagnostician

Name	Description	Value
 Data Logger	Event Status	Normal

- System Configuration



- Network Application

You configure the **Web Server Port**, **Host Idle (timeout)**, and decide whether to enable **Communication WDT** here. The **Web Server Port** decides which Ethernet port can be used for the web service, which includes the web configuration and RESTful Web API. The default port is 80, and if you change the port number as 8080, you need to access the module through `http://192.168.1.1:8080/config` in AP mode for example.

The **Host Idle (timeout)** decides the availability of the TCP connection between the host controller and WISE. MCU-based WISE modules support four TCP connections at the same time for visiting users. It means WISE can be visited by four TCP hosts at the same time, and is not able to connect a fifth host. In this case, if one of the hosts stops communicating with the WISE module for longer than the configured host idle time, default 720 seconds, for example, the WISE module will close the TCP connection with the host.

The Communication WDT has a **Host Idle** time, and will be triggered when all TCP connections are closed. This includes all hosts which visit WISE and also the communication between remote servers like Dropbox or private servers. Once the WDT is enabled, it will trigger systems events like FSV of output channel or system log.

Network Application

Web Server Port (Default:80)	<input type="text" value="80"/>	
Hostidle (Timeout)	<input type="text" value="720"/> <small>sec</small>	
Communication WDT Mode	<input type="text" value="Communication WDT"/>	

- Time & Date / SNTP

You can see the current time here, decide which time zone you use, and calibrate the time by clicking **Click Me** and reading the time from host devices.

Local Time

Current Time	<input type="text" value="2015-10-29T11:42:45+08:00"/>	
Time Zone	<input type="text" value="(GMT+08:00) Taipei"/>	
Time Calibration	<input type="button" value="Click Me..."/>	

You can enable SNTP, so the module can act as an SNTP client to perform time synchronization from an assigned SNTP server.

SNTP

Enable SNTP Client Enabled/Disabled

Primary SNTP Server

SNTP Time Polling Interval sec

Secondary SNTP Server

– Modbus Address

In order to provide users with more flexibility and scalability in deploying modules. It removes the limitation of the Modbus address setting and make it configurable as user's need. There are two Modbus address sections (0X and 4X) for you to configure each function item.

Coils Status(0X)
Holding Registers(4X)

Setting Address

Item	Base	Length
DI Status	<input type="text" value="1"/>	<input type="text" value="4"/>
DO Status	<input type="text" value="17"/>	<input type="text" value="2"/>

– General Configuration

The **Scan Interval** decides the I/O polling interval in the next part of the “I/O Status”. This value will not be saved into the module, so it is only valid until the power is switched off. The **FSV by Communication WDT** decides whether to enable the FSV function triggered by communication with WDT. Enable the FSV function for the entire module's output channels here.

General Configuration

Scan Interval ms

FSV by Communication WDT Enabled/Disabled

ⓘ Note: Each IO will switch to it's FSV if the module's WDT is enabled and it gets triggered.

– Account Management

Change the passwords of each account here.

Account

Type	Password	Authority
Root	Change Password	Read/Write
Admin	Change Password	Read/Write
User	Change Password	Read

■ System Configuration File

Update or Download the configuration file from WISE modules. The following items will be saved in the configuration file:

Configuration	Information, Wireless, Network App, Time & Data, SNTP, Modbus, General Cloud, Account
I/O Status	I/O Configuration, RS-485 (WISE-4051 only)
Advanced	Access Control, Data Logger (Data log and Cloud upload)

- Download configuration file from module

Go to the **Firmware** page in system configuration and click the **Download configuration File** button, the configurations can be saved as a file.

- Update configuration file to module

Go to the **Firmware** page in system configuration and click the icon to select which configuration file is going to be uploaded from the computer. Before uploading the configuration file to the module, select whether or not to apply the IP settings to the WISE module.

■ Firmware Version

- Check Version

The firmware version is shown in the “System Information” page. At the end of the configuration web page, check the version of configuration web page. For normal release module, the version of configuration web page will increase with the firmware version, as these have to be updated at the same time.

Module Information		
Module Name	Module Description	Firmware Description
WISE-4012	2-channels digital output, 4-channels universal input	Fw:A0.91 B00, Bootloader:A0.90 B00

Version : A1.00 B05, Copyright © 2015 By Advantech Corp.

– Update Firmware

Go to the **Firmware** page in system configuration and click the icon to select which firmware file you are going to update. You can find the latest official release firmware file at the Advantech support site (<http://support.advantech.com/support/>).

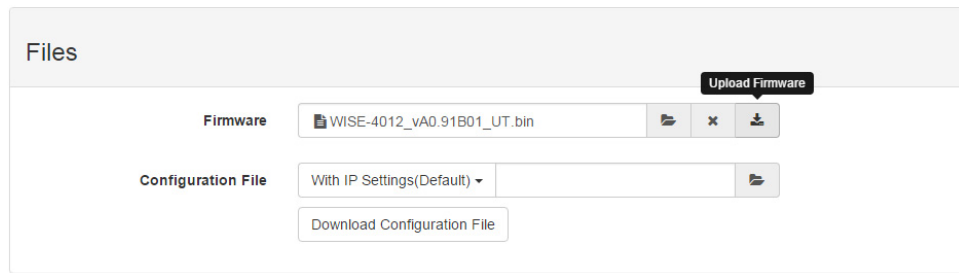

■ Access Control for Security

To avoid unauthorized access, manage which host PC or device can remotely control the WISE-4000 module by IP or MAC Address. Enable one of the rows and enter the IP address or MAC address which allows access to WISE-4000 devices.

Note! For WISE-4000 wireless modules, users can only configure access control by the IP address, not the MAC address.



 Access Control

Enable/Disable <input type="checkbox"/>	IP(Ex: 255.255.255.255)
<input type="checkbox"/> 0	<input type="text" value="255.255.255.255"/>
<input type="checkbox"/> 1	<input type="text" value="255.255.255.255"/>
<input type="checkbox"/> 2	<input type="text" value="255.255.255.255"/>
<input type="checkbox"/> 3	<input type="text" value="255.255.255.255"/>

■ Data Logger

The WISE-4000 series supports data log functions, the I/O status can be logged in the module and also be queried from the module.

– Time & Date / SNTP

Before you start the log function, confirm the RTC time inside the WISE module is configured to the correct time. Standard WISE modules, not including the WISE-4012E, come with an RTC battery. Once the RTC time has been configured, you don't need to synchronize the time with SNTP server. The time will be kept in the RTC with the battery. For the WISE-4012E, which doesn't have an RTC battery, you need to synchronize the time with the SNTP server.

– Data Configuration

◆ I/O Data

You can configure the **Log Conditions** to be logged by time period or by communication with WDT. If you check the **By Period** box, it enables periodic logging, and the log period can be decided in following box. Note that the period is increased by 0.1 seconds, meaning that if the user configures “600” here, the status of the I/O will be logged each minute. If you check the box **By Communication WDT**, it will be enabled, once the condition of the WDT has been met, the status of the I/O will be logged.

For the analog input channel, data can be logged by the AI Deviation Rate (Dividing difference between present sample value and previous sample value by the total range value). Here you can enter the percentage of deviation rate to be the criteria for triggering logger.

All the data can be kept even if the module is powered off, however, you can clear all data in the logger when powering up WISE module. Just check the **Clear Log when Power Up** box. When the data is logged to maximum memory capacity, logger will stop logging by default. You can check the box of the **Circular Log when Memory Full** to overwrite the earliest data.

The screenshot shows the 'I/O Configuration' tab in a web interface. It is divided into three sections:

- Log Conditions:** Contains two checked checkboxes. The first is 'By Period' with a value of '10' and a unit of '0.1 sec'. The second is 'By Communication WDT Log'.
- IO Trigger Log Conditions:** Contains one checked checkbox 'By AI Deviation Rate' with a value of '5' and a '%' symbol.
- General:** Contains two unchecked checkboxes: 'Clear Log when Power Up' and 'Circular Log when Memory Full'.

The **Channel Fields** tab is to decide which I/O channel's status will be logged, and if the change of the status also need to be logged or not. Note that the log memory will be cleared once any parameter is changed in the **Channel Fields**, and also in **IO Fields**.

For a digital channel, check the **Log Enabled** box to log the status of checked channel periodically. Or check the **Change of State** to trigger data logged by status change. For the universal input channel, the DI channel should be configured in **AI/UI** page.

Log Data

Channel Fields
IO Fields

Channel	Log Enabled <input type="checkbox"/>	Change of State <input type="checkbox"/>
0	<input checked="" type="checkbox"/>	<input type="checkbox"/>
1	<input checked="" type="checkbox"/>	<input type="checkbox"/>

All data will be cleared in the data logger if parameter in the "Channel Fields" is changed.

For AI channels, check the **AI Log Enabled** box to log the status of checked channel periodically. Or check **AI Deviation Enabled** to trigger data logged when the AI value changed over the deviation rate which been configured in the page above.

Log Data

Channel Fields
IO Fields

Channel	AI Log Enabled <input type="checkbox"/>	DI Log Enabled <input type="checkbox"/>	AI Deviation Enabled <input type="checkbox"/>	DI Change of State <input type="checkbox"/>
0	<input checked="" type="checkbox"/>	<input checked="" type="checkbox"/>	<input type="checkbox"/>	<input type="checkbox"/>
1	<input checked="" type="checkbox"/>	<input checked="" type="checkbox"/>	<input type="checkbox"/>	<input type="checkbox"/>
2	<input checked="" type="checkbox"/>	<input checked="" type="checkbox"/>	<input type="checkbox"/>	<input type="checkbox"/>
3	<input checked="" type="checkbox"/>	<input checked="" type="checkbox"/>	<input type="checkbox"/>	<input type="checkbox"/>
Avg	<input checked="" type="checkbox"/>	<input type="checkbox"/>	<input type="checkbox"/>	<input type="checkbox"/>

All data will be cleared in the data logger if parameter in the "Channel Fields" is changed.

The **IO Fields** tab is to decide which AI data will be logged. Note that the log memory will be cleared once any parameter changed in the **Channel Fields** and **IO Fields** tabs.

Log Data

Channel Fields
IO Fields

AI Log Data Value Options

Raw <input checked="" type="checkbox"/> Enabled/Disabled	Engineering <input type="checkbox"/> Enabled/Disabled
Max Raw <input type="checkbox"/> Enabled/Disabled	Max Engineering <input type="checkbox"/> Enabled/Disabled
Min Raw <input type="checkbox"/> Enabled/Disabled	Min Engineering <input type="checkbox"/> Enabled/Disabled
After Scaling <input type="checkbox"/> Enabled/Disabled	Status <input checked="" type="checkbox"/> Enabled/Disabled
Physical Value <input type="checkbox"/> Enabled/Disabled	

All data will be cleared in the data logger if parameter in the "IO Fields" is changed.

■ System Data

The WISE data logger function not only logs the I/O status, but also logs system events for module diagnostics or troubleshooting. You can decide what kind of system events you would like to log here.

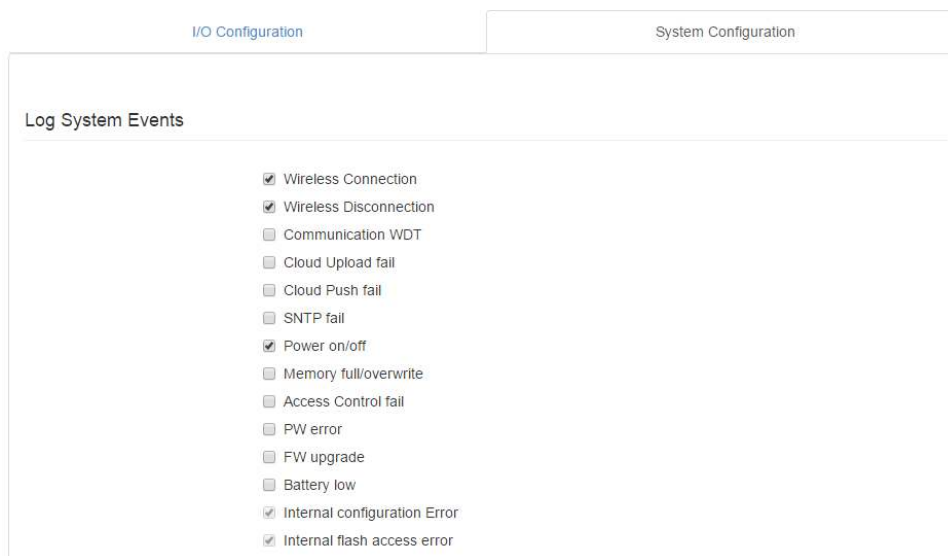

– Logger Configuration

In the previous page, you configured which data is logged. In this page you can enable the local memory storage function. There are separate switches for enabling logging I/O data or system data. You can turn ON the switches to enable logging.



– Local Data Query

The logged data can be queried from the WISE module. Due to the limitation of MCU-based WISE modules, the file will be saved in a *.json file. You can visit <https://json-csv.com/> to convert the data from *.json to *.csv.

Before querying the logged data, you can configure the format of the file. You can decide whether the data comes with a UUID or MAC ID, and decide the type of time stamp. For the latest version WISE module version, which supports **Local Date and Time (GMT)** the time stamp will look like: "2015-08-27T15:20:29+08:00", or if it supports **Coordinated Universal Time (UTC)** that the time stamp will look like: "1440660089".

After deciding the data format you can query the data by the **Amount of Latest Data** for a quantity of data, or by **Time Filter** for a period of data. However, if the amount of data is not too large, you can also choose **No Filter Enabled** to query all the data.

Now you can click **Query** to query the data from local memory. Then the data will be shown in a chart and table. Click **Save** to download the data from the WISE module in a *.json file. Or you can click **Clear** to clear all the data in local memory.

Data Configuration Logger Configuration **Local Data Query**

I/O Data Query System Data Query

IO Data Query Format ▾

UUID Enabled/Disabled MAC ID Enabled/Disabled

Timestamp

Query Filter ▾

Filter Mode

Current Total Amout

Total Amout

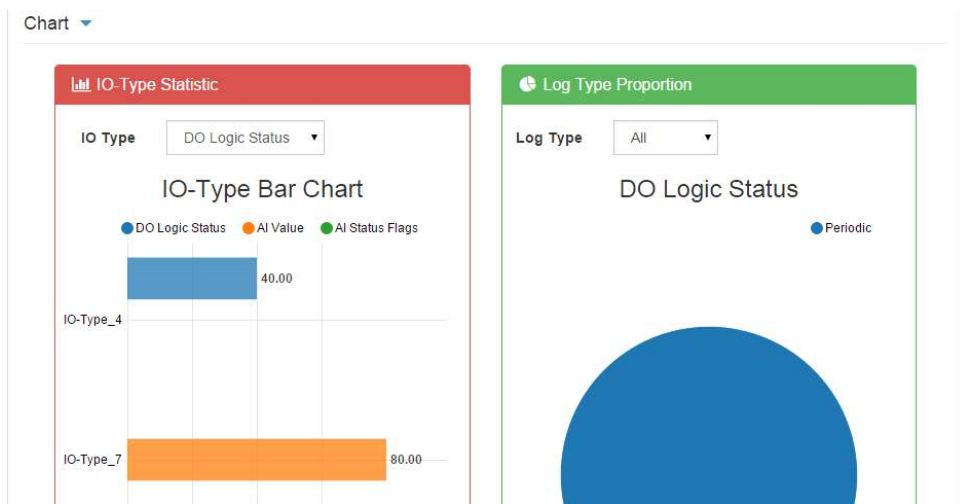

Data ▾

Show entries Search:

Log Type	Timestamp	UUID	Slot	Channel	I/O-type	Value
128	1446090622	WISE-4012_00D0C9CC0099	0	0	4	0
128	1446090622	WISE-4012_00D0C9CC0099	0	1	4	0
128	1446090622	WISE-4012_00D0C9CC0099	0	0	7	32767

- Cloud Logger (WISE-4000 wireless series only)
 - Dropbox

Refer to section **4.2.8 Configuring Cloud Server** for Dropbox cloud logger.

– Private Server

If you don't want to push the data to public file-based cloud like Dropbox, WISE also supports the **Private Server** function which pushes data to a private web server setup by yourself. You can setup your own web service to receive the data from WISE module, or use the example agent on your own server to receive the files pushed from the WISE module.

Go to the **Cloud Configuration** page and select the service as **Private Server**. Then configure the **Private Server Setting**. If you would like to use the example agent provided by WISE, you need to confirm the **Server IP** and **Server Port**, and make sure the server port you've configured had not been occupied by another application on your private server. To setup your own application to receive the file from WISE, you may need to configure the URL. SSL security also supports Dropbox to provide you with a safe private cloud solution. Once SSL security had been enabled, you need to setup the SSL service on your private server.

The screenshot shows the 'Cloud Configuration' interface. At the top, there is a 'Select Service' dropdown menu with 'Private Server' selected. Below this is the 'Private Server Setting' section, which contains several input fields and a radio button group. The fields are: 'Server IP' (172.18.3.16), 'Server Port' (8000), 'Data File Upload URL' (/upload_log), 'IO Data Push URL' (/io_log), and 'System Event Push URL' (/sys_log). At the bottom of this section, there is an 'SSL secure' option with 'Disable' selected and 'Enable' unselected.

If you are not able to setup the SSL service, there is another option for safety. You can have **Authentication** for the private server with a **User Name** and **Password** which is also provided by our example agent.

The screenshot shows the 'Authentication' section of the configuration page. It features a 'Type' dropdown menu set to 'Basic Authorization'. Below this are two input fields: 'User Name' (root) and 'Password' (00000000).

After **Cloud Configuration** had been configured as a private server, you can go back to the **Logger Configuration** page in **Data Logger**. Before switching Cloud Upload to ON, you can configure the data upload criteria, and for I/O signal or system diagnosis individually. The criteria can be **Item Periodic Interval mode** for pushing data by a quantity of data, or **Time Periodic Interval mode** for pushing data by a period of time (Unit: 0.1 sec). If you don't want to upload the I/O or system data, choose **Disable**. After the upload criteria have been configured, you can switch **Cloud Upload** ON and start uploading. Then the data will be pushed to the cloud in *.csv file.

Cloud Upload

Cloud Upload

Signal Measurement Upload

Data Upload: Item Periodic Interval mode

20 Item

File Tag:

System Diagnosis Upload

Data Upload: Disable

File Tag:

– Push Notification

For Cloud Logger functions Private Server, the data all comes from the local memory of WISE, so you can see it from the WISE data logger and make a batch of data as a file, then push it to the web server. Then push the latest data when the log condition has been triggered, like the changes of DI status. The WISE module will push a notification in JSON format to the private server as configured above, and then you have the latest WISE module data. You can switch the **I/O Log** or **System Log** ON, then the WISE module will start pushing the latest logged data to the private server.

Push Notification

I/O Log OFF

System Log OFF

4.2.8 Configuring Cloud Server (WISE-4000 wireless series only)

1. Make sure the WISE-4000 module is able to access the Internet, and the device that's going to configure the WISE-4000 module is within the same IP domain as the WISE-4000 module
2. Go to the Cloud tab of Configuration.

Note! *The following instructions use Dropbox. Make sure Dropbox provide their service in your region or find an alternative public cloud service.*



3. Select Dropbox as the cloud server.

A screenshot of the 'Cloud Configuration' web interface. It features a title 'Cloud Configuration' at the top. Below it is a 'Cloud Server' dropdown menu with 'Dropbox' selected. Underneath is a 'Link Status' field, which is currently empty and has a refresh icon to its right. At the bottom right of the form is a red button labeled 'Authenticate' with a checkmark icon.

4. The browser will open a new window for Dropbox. Enter your Dropbox account information including E-mail and Password, then click "Sign in".

A screenshot of a web browser window showing the Dropbox sign-in page. The browser title is 'Dropbox - API Request Authorization - Sign in - Google Chrome'. The address bar shows 'Dropbox, Inc [US] https://www.dropbox.com/1/oauth2/authorize?cli'. The page content includes the Dropbox logo, the text 'Sign in to Dropbox to link with WISE Cloud Logger', an 'Email' input field, a 'Password' input field, a 'Forgot your password?' link, and a blue 'Sign in' button.

5. After logging in, click "Allow" to allow WISE Cloud Logger Apps to access your Dropbox account to store the data log file.

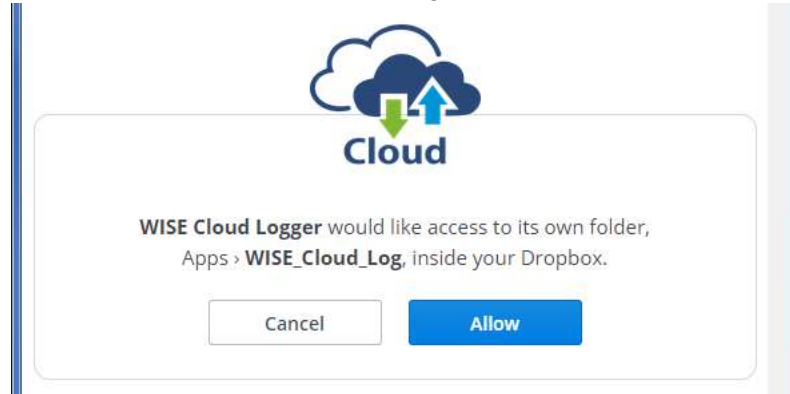

6. Dropbox will then provide a code, copy this code and return to the configuration web page of the WISE module.

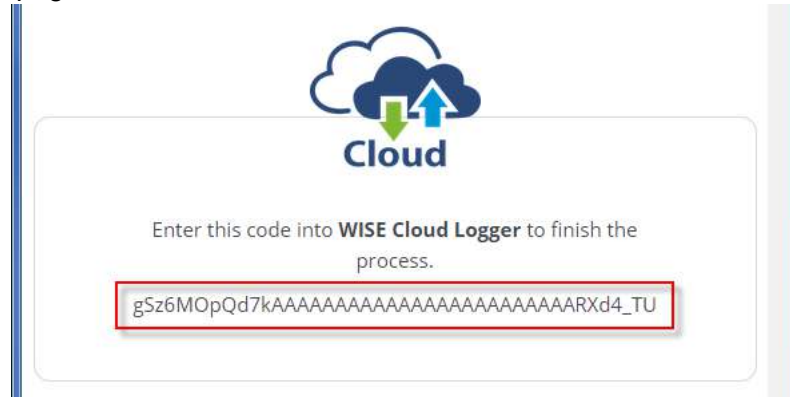

7. Click "Next" to enter the code.

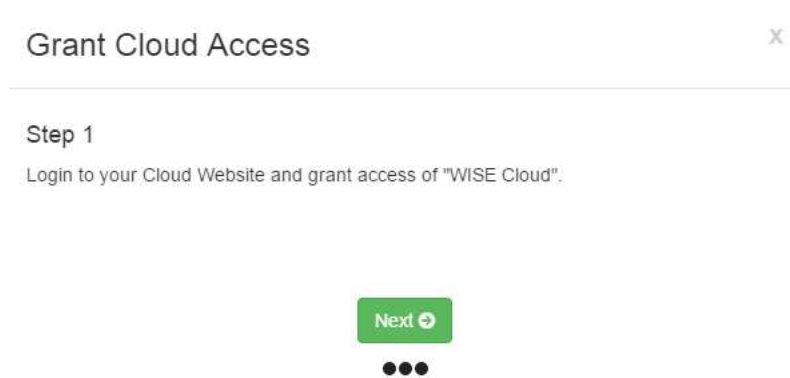

8. Paste the code provided by WISE Cloud Logger, then click "Submit".

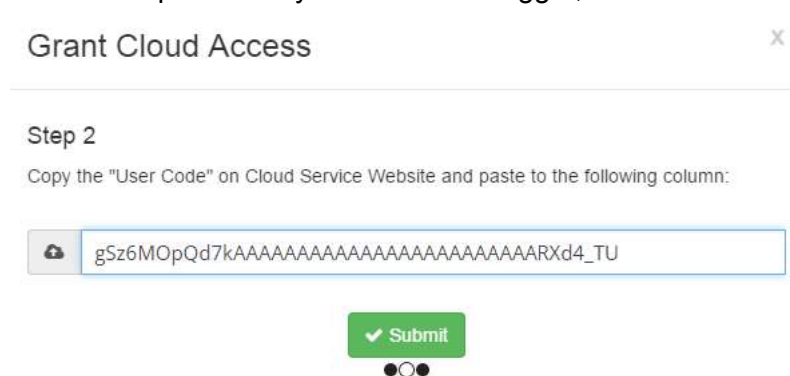

9. If your WISE-4000 module is correctly connected to the Internet, you will be able to set the functions successfully. Click "Close" to return to Configuration.

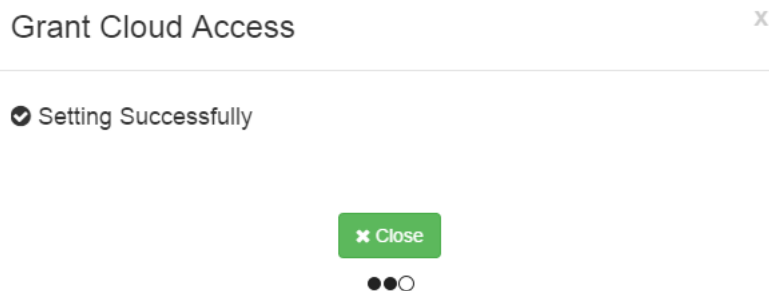

10. You will then be able to see the "Link Status" shows "Ready".

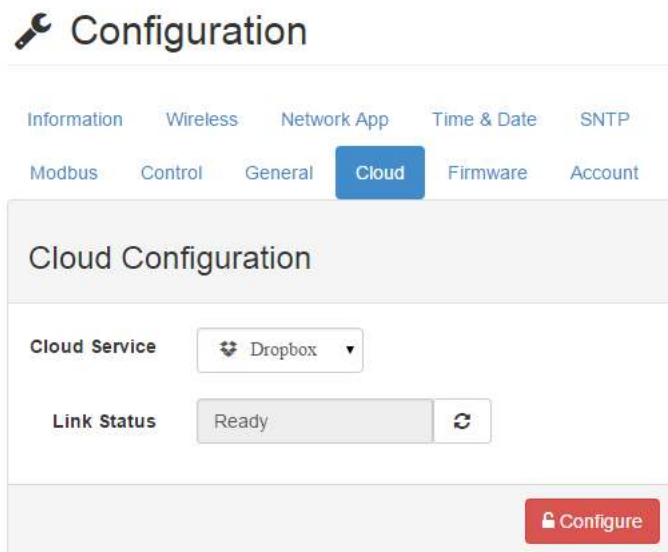

4.3 Configure WISE-4000 with ADAM.NET Utility

ADAM.NET Utility, which is designed with graphical operation interface, is aimed to offer users directly configure, control WISE-4000 module, and monitor the real-time status of remote WISE-4000 module via Ethernet or Wireless connection.

To keep you informed with latest update, you also can check it from the following download link on Advantech website.

http://support.advantech.com.tw/Support/DownloadSRDetail.aspx?SR_ID=1-2AKUDB

Note! ■ Before installing ADAM.NET Utility, you need to install .NET Framework 2.0 or higher version.



■ System requirement

- Microsoft Windows XP/7
- At least 32 MB RAM
- 20 MB of hard disk space available
- VGA color or higher resolution monitor
- Mouse or other pointing devices
- 10/100 Mbps or higher Ethernet Card

1. Install ADAM.NET Utility in your computer.
(After successfully installation, there will be a shortcut generated on the screen)



2. Double click the shortcut icon, and then you will see the main operation window.
3. Click Search Module icon in Toolbar. You will see all online modules in the left Module Tree screen and an unconfigured new module, whose default password is 00000000, will appear on the Others section as below. Now you can define the network mode of the module in the beginning. After that, you will be able to perform other settings.

Note! The default password is 00000000



4.3.1 Operation Framework

The operation window mainly contains 4 areas, including Menu, Toolbar, Module Tree screen and Main Operation screen.

4.3.1.1 Menu

a. File

■ Open Favorite Group

You can import the favorite configuration group file (.XML) from your computer.

- **Save Favorite Group**
You can save the favorite group configuration group as XML file to your computer.
- **Auto-Initial Group**
If you want to have the same favorite group configuration when you exit ADAM.NET utility and launch it again, you need to check this option.
- **Exit**
Exit ADAM.NET Utility.

b. Tools

■ Search Device

Search all the WISE-4000 modules you connected in local Ethernet.

■ Add Devices to Group

It's used to add WISE-4000 modules to your favorite group. After activating search function, all online modules will show on Module Tree Screen area. Now you can enable this function to select the device you want to add in the Module Tree Screen.

■ Group Configuration

Group Configuration is on WISE-4000 series module. It can help you efficiently configure or maintain massive WISE-4000 modules with the same configuration file or firmware upgrade at one time in the local network. The following steps will instruct you how to operate it.

■ Terminal for Command Testing

WISE-4000 series module Modbus/TCP as communication protocol, so you can launch the terminal to directly communicate with WISE-4000 series module by these two protocols.

■ Print Screen

You can save current ADAM.NET Utility screen into an image file by this option.

■ HTML File Packager

You can pack your user web page by this tool:

- 1.Put all the files that going to pack in same folder, and "Browse..." the folder
- 2.Press "Save as..." and give a file name after package
- 3.Check all the files had been selected in "File List"
- 4.Check "Gzip Compression" to reduce the file size
- 5.After press the "Apply" button, your user web page will be compressed as "*.ehf" file, then you can download the file into your WISE module

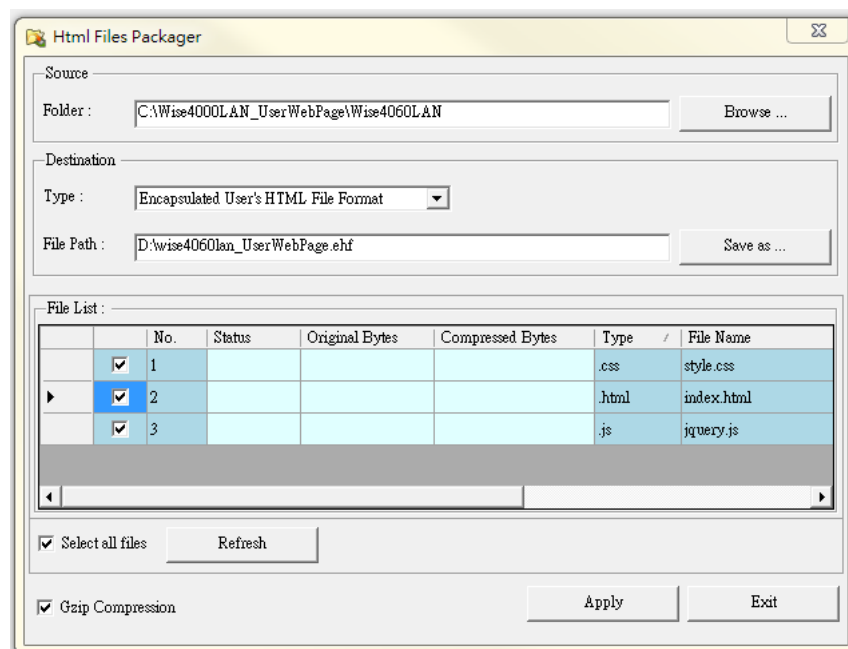

c. Setup

■ **Favorite Group**

You can configure your favorite group including add one new device, modify or delete one current device, sort current devices and diagnose connection to one device.

■ **Refresh Serial and Ethernet**

ADAM.NET utility will refresh the serial and LAN network connection situation.

■ **Add COM Ports**

This option is used to add serial COM ports in ADAM.NET Utility. You won't need to use this option for WISE-4000 modules.

■ **Show TreeView**

Check this option to display the Module Tree Screen area.

■ **Allow Calibration**

Check this option to allow calibration function enabled on AI/O module.

d. Help

■ **Check Up-to-Date on the Web**

It will automatically connect to support and download page of Advantech website when it enabled. You can find and download the latest version of WISE-4000 utility there.

■ **About ADAM.NET Utility**

The current version of ADAM.NET Utility is installed on your computer.

4.3.1.2 Toolbar

There are 8 graphical icons for common used options of Menu on the toolbar.

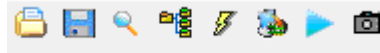

Definition (from left to right)

1. Open favorite group
2. Save favorite group
3. Search Modules
4. Add Devices to Group
5. Terminal for Command Testing
6. Group Configuration
7. Monitor Data Stream/Event
8. Print Screen

4.3.1.3 Module Tree Screen

The Module Tree Screen locates on the left part of ADAM.NET utility operation window. There are four categories in this area:

Serial

All serial I/O Modules (ADAM-4000 and ADAM-5000 RS-485 serial modules) connected to the host PC will be listed in this category.

Ethernet

All Ethernet I/O Modules (WISE-4000, ADAM-6000, ADAM-6100, and ADAM-5000 TCP modules) connected to the host PC will be listed in this category.

Favorite Group

You can define which devices listed in the three categories above into your personal favorite group. This will make you easier to find your interested modules. Right click on the WISE-4000 device item under the Favorite Group item and you can select Add New Group to create a new group. After you create your own group, right click on your group and Add New Device into your group. You can also select Diagnose connection to check the communication.

ADAM-4500_5510 Series

This is a DOS interface utility for remote controllers such as ADAM-4500 and ADAM-5510 series.

Wireless Sensor Networks

All wireless I/O Modules (ADAM-2000 modules) connected to the host PC, through wireless gateway, will be listed in this category.

4.3.1.4 Main Operation Screen

Main Operation Screen located on the right side of utility includes I/O status display and function setting. You can select different items in Module Tree Screen, and then Main Operation Screen will change dependently. You can do all configurations and test in this area.

In Information page (after clicking Ethernet), you can configure Connection/Send/Receive/Scan Timeout. The supervisor password is a shortcut to let you enter a password at one time which's applied for certain modules, so you don't need to enter the same password for each module when you check it.

4.3.2 Configure WISE-4000

1. Configure the computer's IP address as the same domain as WISE-4000 module. For the new WISE-4000/LAN Series which default IP address is 10.0.0.1, the IP address of computer can be configured as 10.0.0.99 for example as following.
2. Open the Adam/Apax .NET Utility then you can see the IP address of computer been shown under "Ethernet" tree. You can right click to refresh the subnodes of this tree. Or click "Search Device" to find WISE-4000 module.

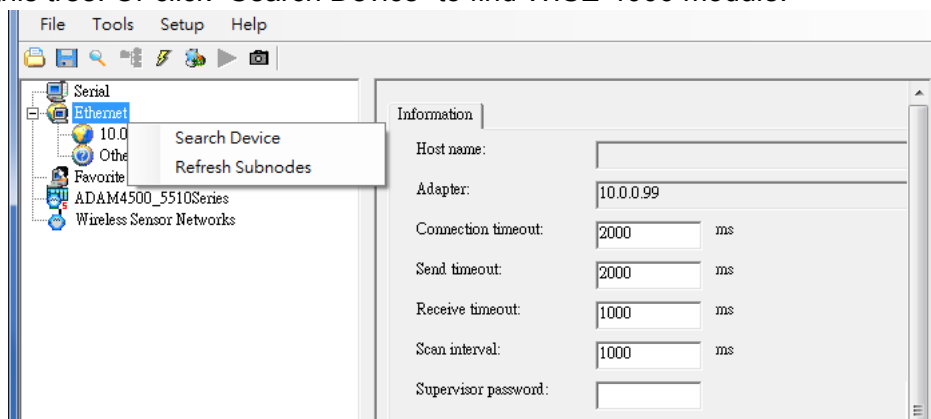

3. Users can also right click the IP address to find WISE-4000 module.

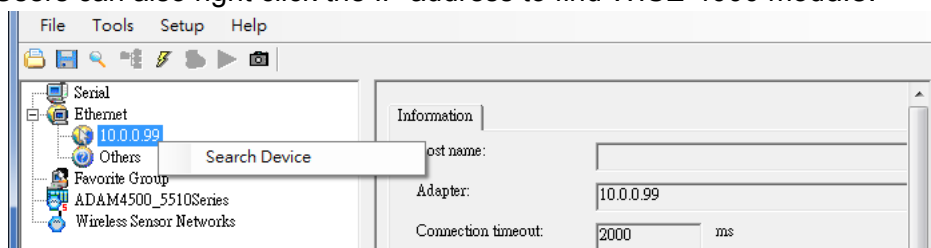

- After the module been found, it will be listed under IP address in same domain, you can login the embedded web configuration web page for further configuration as introduced in previous section

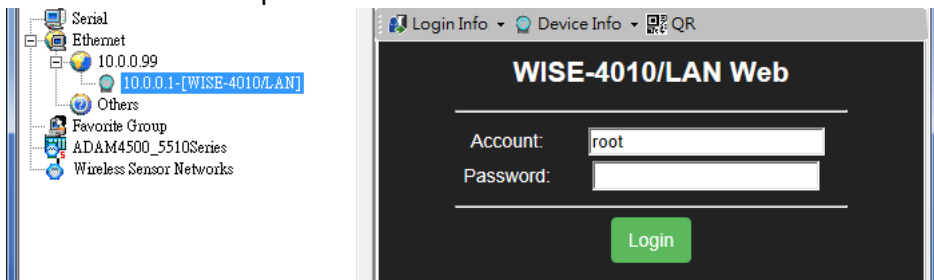

- There are some function provide in same pages in utility, first you can enter the account and password faster in "Login Info" tab.

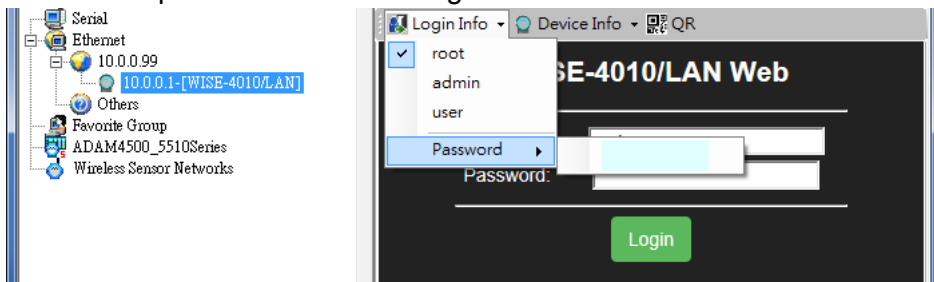

- In the "Device Info" tab, the detail information of this module will be shown

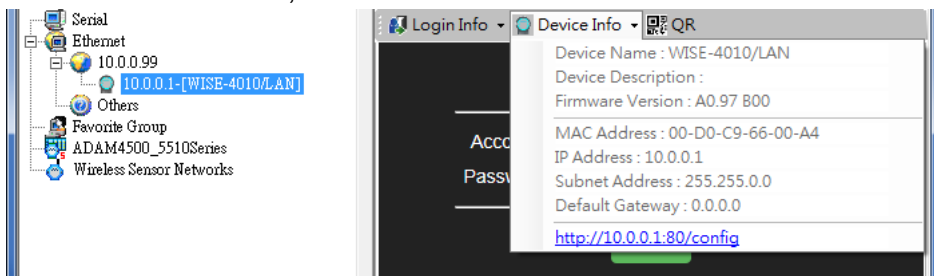

- The "QR" tab will generate the QR code of the web configuration web page for mobile device to access the module. User can also click the QR code to open the browser for further configuration.



Note! *If you are not able to search the module, you can configure the SW1 behind the module to initial mode. After power up and search the module in utility, user can find the module with default IP address, and the device name will be shown in "Others" tree with (*) sign. So user can change the device network setting in this page. Or try to locate the device and also reset the password with same page. After the new network setting been apply, please configure the SW1 back to normal mode and power up again to reboot in new network setting.*

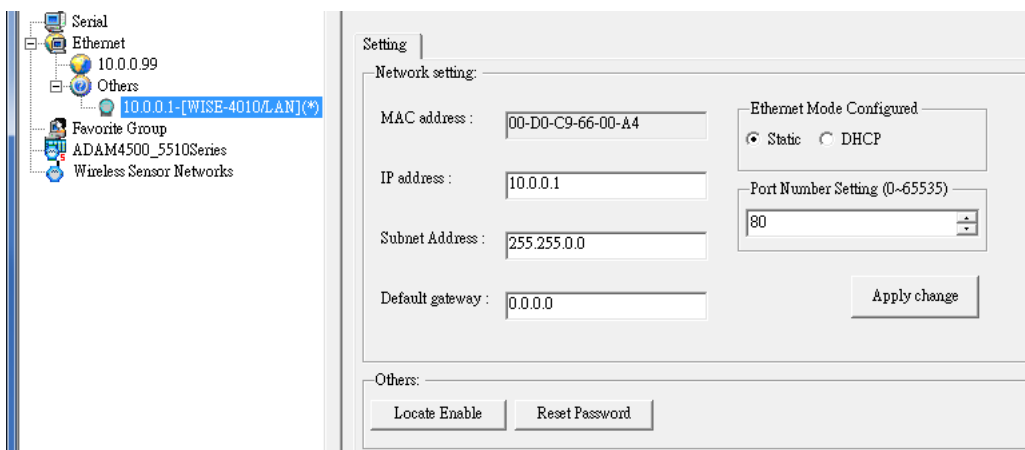

4.4 Site Survey Tool for WISE-4000 Wireless Series

WISE-4000 Wireless Series provides Site Survey Tool for testing the communication quality between WISE-4000 wireless module with wireless access point or wireless router.

4.4.1 Site Survey Architecture

Wiring the wireless AP with the PC installed with Site Survey Tool (Utility), if possible, the network should only have PC, AP, and WISE-4000 only.

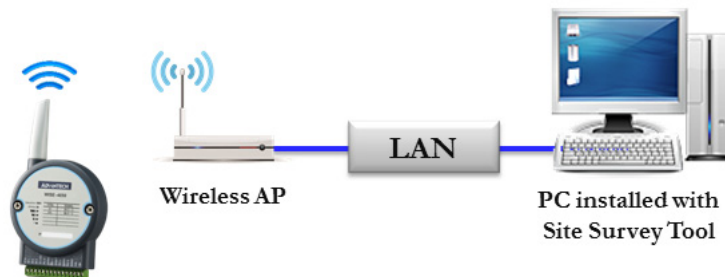

4.4.2 Site Survey Mode

WISE module will go to site survey mode operation for testing communication quality. Most of the functions of WISE module will temporarily stop to doing site survey operation. And the LED status will work as following:

LED	Color	Indication	Behavior
Status	Green	OFF	Site Survey mode
Com	Yellow	Blink	Site Survey data packet TX/RX
AP/Infra	Green	OFF	Site Survey mode (Station Mode)
Signal Strength	Green	Blink	Site Survey mode

4.4.3 Site Survey Tool

Search WISE-4000 module as described in the last section, after click the module shown in Ethernet tree. There is a "Site Survey" icon as following. Click the "Site Survey" icon to open site survey tool windows as following. Click "Start" to set the module in site survey mode and start the site survey tool. User can click "Restart" to restart the testing result, or click "Stop" to stop the testing and set the module back to normal operation.

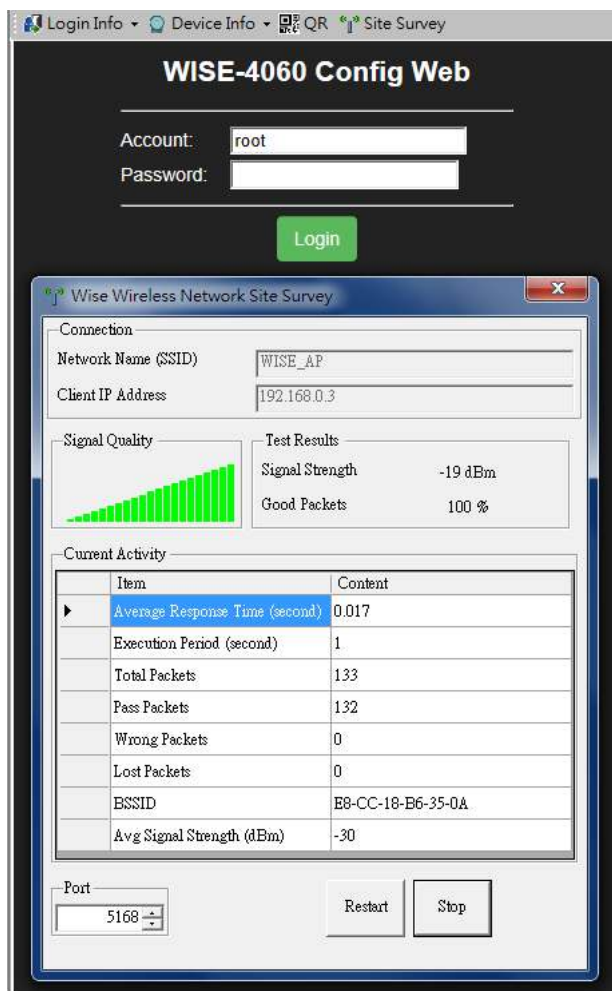

Connection

Network Name (SSID): Show which wireless AP is connected.

Client IP Address: Show the IP address of the wireless adapter of PC

Signal Quality

Show the signal strength by bar chart

Testing Results

Signal Strength: The average result of the signal strength during testing

Good Package: The percentage of passed packets during testing

Current Activity

Detail information of each testing packets

Port

User can configure which UDP port of PC is assigned for site survey testing

Appendix **A**

I/O Modbus Mapping Table

A.1 Modbus Function Code Introduction

To full-fill the programming requirement, there is a series of function code standard for user's reference.

Code (Hex)	Name	Usage
01	Read Coil Status	Read Discrete Output Bit
02	Read Input Status	Read Discrete Input Bit
03	Read Holding Registers	Read 16-bit register. Used to read integer or floating point process data.
04	Read Input Registers	
05	Force Single Coil	Write data to force coil ON/OFF
06	Preset Single Register	Write data in 16-bit integer format
08	Loopback Diagnosis	Diagnostic testing of the communication port
0F	Force Multiple Coils	Write multiple data to force coil ON/OFF
10	Preset Multiple Registers	Write multiple data in 16-bit integer format

A.2 WISE-4010/LAN Modbus Mapping Table

Address (0X):

Address (0X)	Channel	Description	Attribute
00017	0	DO Value	Read/Write
00018	1		Read/Write
00019	2		Read/Write
00020	3		Read/Write
00101	0	Reset Historical Maximum AI Value	Write
00102	1		Write
00103	2		Write
00104	3		Write
00105	Average Ch 0~3		Write
00111	0	Reset Historical Min. AI Value	Write
00112	1		Write
00113	2		Write
00114	3		Write
00115	Average Ch 0~3		Write
00121	0	Open-Circuit Flag (Burnout)	Read
00122	1		Read
00123	2		Read
00124	3		Read

00131	0		Read
00132	1		Read
00133	2	High Alarm Flag	Read
00134	3		Read
00135	Average Ch 0~3		Read

00141	0		Read
00142	1		Read
00143	2	Low Alarm Flag	Read
00144	3		Read
00145	Average Ch 0~3		Read

Address (4X):

Address (4X)	Channel	Description	Attribute
40211		Module Name 1	Read
40212		Module Name 2	Read

40221	All AI	AI Channel Enabled	Read/Write
-------	--------	--------------------	------------

40303	All DO	DO Value	Read/Write
-------	--------	----------	------------

40001	0		Read
40002	1		Read
40003	2	AI Value	Read
40004	3		Read
40005	Average Ch 0~3		Read

40009-40010	0		Read/Write
40011~40012	1	Pulse Output	Read/Write
40013~40014	2	Low Level Width	Read/Write
40015~40016	3		Read/Write

40017-40018	0		Read/Write
40019~40020	1	Pulse Output	Read/Write
40021~40022	2	High Level Width	Read/Write
40023~40024	3		Read/Write

40025-40026	0		Read/Write
40027~40028	1	Pulse Output Number	Read/Write
40029~40030	2	(0 for continuous output)	Read/Write
40031~40032	3		Read/Write

40033~40034	0	Set Incremental Pulse Output Number	Read/Write
40035~40035	1		Read/Write
40037~40038	2		Read/Write
40037~40040	3		Read/Write
40101~40102	0	AI Status*	Read
40103~40104	1		Read
40105~40106	2		Read
40107~40108	3		Read
40111	0	Historical Maximum AI Value	Read
40112	1		Read
40113	2		Read
40114	3		Read
40115	Average Ch 0~3		Read
40121	0	Historical Minimum AI Value	Read
40122	1		Read
40123	2		Read
40124	3		Read
40125	Average Ch 0~3		Read
40131~40132	0	AI Floating Value (IEEE754)	Read
40133~40134	1		Read
40135~40136	2		Read
40137~40138	3		Read
40139~40140	Average Ch 0~3		Read
40151~40152	0	Historical Maximum AI Floating Value (IEEE754)	Read
40153~40154	1		Read
40155~40156	2		Read
40157~40158	3		Read
40159~40160	Average Ch 0~3		Read
40171~40172	0	Historical Minimum AI Floating Value (IEEE754)	Read
40173~40174	1		Read
40175~40176	2		Read
40177~40178	3		Read
40179~40180	Average Ch 0~3		Read
40191	0	AI Value After Scaling	Read
40192	1		Read
40193	2		Read
40194	3		Read
40195	Average Ch 0~3		Read

40201	0		Read/Write
40202	1		Read/Write
40203	2	AI Type Code**	Read/Write
40204	3	(The type codes of channels for	Read/Write
40205	Average Ch 0~3	average value can't be changed.)	Read

* AI Status (2 Registers)

Lower Register		Higher Register	
Bit	Description	Bit	Description
0	Fail to Provide AI Value	0	DI triggered to Safety Value
1	Over Range	1	DI triggered to Startup Value
2	Under Range	2	Reserved
3	Open Circuit / Burnout	3	Reserved
4	Reserved	4	Reserved
5	Reserved	5	Reserved
6	Reserved	6	Reserved
7	ADC Initializing/Error	7	Reserved
8	Reserved	8	Reserved
9	Zero/Span Calibration Error	9	Reserved
10	Reserved	10	Reserved
11	Reserved	11	Reserved
12	Reserved	12	Reserved
13	Reserved	13	Reserved
14	Reserved	14	Reserved
15	Reserved	15	Reserved

** AI Type Code (2 Registers)

Type Code	Input Range
0x1080	4~20 mA
0x1082	0~20 mA

A.3 WISE-4050/LAN Modbus Mapping Table

Address 0X	Channel	Description	Attribute
00001	0	DI Value	Read
00002	1		Read
00003	2		Read
00004	3		Read
00017	0	DO Value	Read/Write
00018	1		Read/Write
00019	2		Read/Write
00020	3		Read/Write
00033	0	Counter Status (0: stop 1: start)	Read/Write
00034	1		Read/Write
00035	2		Read/Write
00036	3		Read/Write
00037	0	Clear Counter (1: write to clear value)	Write
00038	1		Write
00039	2		Write
00040	3		Write
00041	0	Clear Overflow (1: counter overflow, auto set to 0 after read)	Read/Write
00042	1		Read/Write
00043	2		Read/Write
00044	3		Read/Write
00045	0	DI Latch Status (1: DI latched, 0: write to clear latch)	Read/Write
00046	1		Read/Write
00047	2		Read/Write
00048	3		Read/Write
Address 4X	Channel	Description	Attribute
40211	-	Module Name 1	Read
40212	-	Module Name 2	Read
40301	All DI	DI Value	Read
40303	All DO	DO Value	Read/Write
40001~40002	0	Counter/Frequency Value	Read
40003~40004	1		Read
40005~40006	2		Read
40007~40008	3		Read

40009~40010	0		Read/Write
40011~40012	1	Pulse Output	Read/Write
40013~40014	2	Low Level Width	Read/Write
40015~40016	3		Read/Write
40017~40018	0		Read/Write
40019~40020	1	Pulse Output	Read/Write
40021~40022	2	High Level Width	Read/Write
40023~40024	3		Read/Write
40025~40026	0		Read/Write
40027~40028	1	Set Absolute	Read/Write
40029~40030	2	Pulse Output Number	Read/Write
40031~40032	3	(0 for continuous output)	Read/Write
40033~40034	0		Read/Write
40035~40036	1	Set Incremental	Read/Write
40037~40038	2	Pulse Output Number	Read/Write
40039~40040	3		Read/Write

A.4 WISE-4060/LAN Modbus Mapping Table

Address 0X	Channel	Description	Attribute
00001	0	DI Value	Read
00002	1		Read
00003	2		Read
00004	3		Read
00017	0	DO Value	Read/Write
00018	1		Read/Write
00019	2		Read/Write
00020	3		Read/Write
00033	0	Counter Status (0: stop 1: start)	Read/Write
00034	1		Read/Write
00035	2		Read/Write
00036	3		Read/Write
00037	0	Clear Counter (1: write to clear value)	Write
00038	1		Write
00039	2		Write
00040	3		Write
00041	0	Clear Overflow (1: counter overflow, auto set to 0 after read)	Read/Write
00042	1		Read/Write
00043	2		Read/Write
00044	3		Read/Write
00045	0	DI Latch Status (1: DI latched, 0: write to clear latch)	Read/Write
00046	1		Read/Write
00047	2		Read/Write
00048	3		Read/Write
Address 4X	Channel	Description	Attribute
40211	-	Module Name 1	Read
40212	-	Module Name 2	Read
40301	All DI	DI Value	Read
40303	All DO	DO Value	Read/Write
40001~40002	0	Counter/Frequency Value	Read
40003~40004	1		Read
40005~40006	2		Read
40007~40008	3		Read

40009~40010	0		Read/Write
40011~40012	1	Pulse Output	Read/Write
40013~40014	2	Low Level Width	Read/Write
40015~40016	3		Read/Write
40017~40018	0		Read/Write
40019~40020	1	Pulse Output	Read/Write
40021~40022	2	High Level Width	Read/Write
40023~40024	3		Read/Write
40025~40026	0		Read/Write
40027~40028	1	Set Absolute	Read/Write
40029~40030	2	Pulse Output Number	Read/Write
40031~40032	3	(0 for continuous output)	Read/Write
40033~40034	0		Read/Write
40035~40036	1	Set Incremental	Read/Write
40037~40038	2	Pulse Output Number	Read/Write
40039~40040	3		Read/Write

A.5 WISE-4012E Wireless Modbus Mapping Table

Address 0X	Channel	Description	Attribute
00001	0	DI Value	Read
00002	1		Read
00017	0	DO Value	R/W
00018	1		R/W
00033	0	Counter Status (0: stop 1: start)	R/W
00034	1		R/W
00035	0	Clear Counter (1: write to clear value)	Write
00036	1		Write
00037	0	Clear Overflow (1: counter overflow, auto set to 0 after read)	R/W
00038	1		R/W
00039	0	DI Latch Status (1: DI latched, 0: write to clear latch)	R/W
00040	1		R/W
00101	0	Reset Historical Maximum AI Value	Write
00102	1		Write
00103	Average Channel 0~1		Write
00111	0	Reset Historical Minimum AI Value	Write
00112	1		Write
00113	Average Channel 0~1		Write
00131	0	High Alarm Flag	Read
00132	1		Read
00133	Average Channel 0~1		Read
00141	0	Low Alarm Flag	Read
00142	1		Read
00143	Average Channel 0~1		Read
Address 4X	Channel	Description	Attribute
40211		Module Name 1	Read
40212		Module Name 2	Read
40221	All AI	AI Channel Enable	R/W

40301	All DI	DI Value	Read
40303	All DO	DO Value	R/W
40001	0	AI Value (Value Range: 0~10000, Value Unit: mV)	Read
40002	1		Read
40003	Average Channel 0~1		Read
40017~40018	0	Counter/Frequency Value	R/W
40019~40020	1		R/W
40021~40022	0	Pulse Output Low Level Width	R/W
40023~40024	1		R/W
40025~40026	0	Pulse Output High Level Width	R/W
40027~40028	1		R/W
40029~40030	0	Set Absolute Pulse Output Number (0 for continuous output)	R/W
40031~40032	1		R/W
40033~40034	0	Set Incremental Pulse Output Number	R/W
40035~40036	1		R/W
40101~40102	0	AI Status*	Read
40103~40104	1		Read
40111	0	Historical Maximum AI Value	Read
40112	1		Read
40113	Average Channel 0~1		Read
40121	0	Historical Minimum AI Value	Read
40122	1		Read
40123	Average Channel 0~1		Read
40131~40132	0	AI Floating Value (IEEE754)	Read
40133~40134	1		Read
40135~40136	Average Channel 0~1		Read
40151~40152	0	Historical Maximum AI Floating Value (IEEE754)	Read
40153~40154	1		Read
40155~40156	Average Channel 0~1		Read

40171~40172	0	Historical Minimum AI Floating Value (IEEE754)	Read
40173~40174	1		Read
40175~40176	Average Channel 0~1		Read
40191	0	AI Value After Scaling	Read
40192	1		Read
40193	Average Channel 0~1		Read
40201	0	AI Type Code** (The type codes of channels for average value can't be changed.)	R/W
40202	1		R/W
40203	Average Channel 0~1		R

*** AI Status (2 Registers)**

Lower Register		Higher Register	
Bit	Description	Bit	Description
0	Fail to Provide AI Value	0	DI triggered to Safety Value
1	Over Range	1	DI triggered to Startup Value
2	Under Range	2	Reserved
3	Open Circuit / Burnout	3	Reserved
4	Reserved	4	Reserved
5	Reserved	5	Reserved
6	Reserved	6	Reserved
7	ADC Initializing/Error	7	Reserved
8	Reserved	8	Reserved
9	Zero/Span Calibration Error	9	Reserved
10	Reserved	10	Reserved
11	Reserved	11	Reserved
12	Reserved	12	Reserved
13	Reserved	13	Reserved
14	Reserved	14	Reserved
15	Reserved	15	Reserved

**** AI Type Code (2 Registers)**

Type Code	Input Range
0x0148	0~10 V

A.6 WISE-4012 Wireless Modbus Mapping Table

Address 0X	Channel	Description	Attribute
00001	0	DI Value	Read
00002	1		Read
00003	2		Read
00004	3		Read
00017	0	DO Value	R/W
00018	1		R/W
00033	0	Counter Status (0: stop 1: start)	R/W
00034	1		R/W
00035	2		R/W
00036	3		R/W
00037	0	Clear Counter (1: write to clear value)	Write
00038	1		Write
00039	2		Write
00040	3		Write
00041	0	Clear Overflow (1: counter overflow, auto set to 0 after read)	R/W
00042	1		R/W
00043	2		R/W
00044	3		R/W
00045	0	DI Latch Status (1: DI latched, 0: write to clear latch)	R/W
00046	1		R/W
00047	2		R/W
00048	3		R/W
00101	0	Reset Historical Maximum AI Value	Write
00102	1		Write
00103	2		Write
00104	3		Write
00105	Average Channel 0~3		Write
00111	0	Reset Historical Minimum AI Value	Write
00112	1		Write
00113	2		Write
00114	3		Write
00115	Average Channel 0~3		Write

00131	0		Read
00132	1		Read
00133	2	High Alarm Flag	Read
00134	3		Read
00135	Average Channel 0~3		Read
00141	0		Read
00142	1		Read
00143	2	Low Alarm Flag	Read
00144	3		Read
00145	Average Channel 0~3		Read
Address 4X			
40211		Module Name 1	Read
40212		Module Name 2	Read
40221	All AI	AI Channel Enable	R/W
40301	All DI	DI Value	Read
40303	All DO	DO Value	R/W
40001	0	AI Value	Read
40002	1		Read
40003	2		Read
40004	3		Read
40005	Average Channel 0~1		Read
40017~40018	0	Counter/Frequency Value	R/W
40019~40020	1		R/W
40021~40022	2		R/W
40023~40024	3		R/W
40025~40026	0	Pulse Output Low Level Width	R/W
40027~40028	1		R/W
40029~40030	0	Pulse Output High Level Width	R/W
40031~40032	1		R/W
40033~40034	0	Set Absolute Pulse Output Number (0 for continuous output)	R/W
40035~40036	1		R/W
40037~40038	0	Set Incremental Pulse Output Number	R/W
40039~40040	1		R/W

40101~40102	0	AI Status*	Read
40103~40104	1		Read
40105~40106	2		Read
40107~40108	3		Read
40111	0	Historical Maximum AI Value	Read
40112	1		Read
40113	2		Read
40114	3		Read
40115	Average Channel 0~3		Read
40121	0	Historical Minimum AI Value	Read
40122	1		Read
40123	2		Read
40124	3		Read
40125	Average Channel 0~3		Read
40131~40132	0	AI Floating Value (IEEE754)	Read
40133~40134	1		Read
40135~40136	2		Read
40137~40138	3		Read
40139~40140	Average Channel 0~3		Read
40151~40152	0	Historical Maximum AI Floating Value (IEEE754)	Read
40153~40154	1		Read
40155~40156	2		Read
40157~40158	3		Read
40159~40160	Average Channel 0~3		Read
40171~40172	0	Historical Minimum AI Floating Value (IEEE754)	Read
40173~40174	1		Read
40175~40176	2		Read
40177~40178	3		Read
40179~40180	Average Channel 0~3		Read
40191	0	AI Value After Scaling	Read
40192	1		Read
40193	2		Read
40194	3		Read
40195	Average Channel 0~3		Read

40231~40232	0		Read
40233~40234	1		Read
40235~40236	2	Physical AI Floating Value (IEEE754)	Read
40237~40238	3		Read
40239~40240	Average Channel 0~3		Read
40201	0		R/W
40202	1	AI Type Code** (The type codes of chan- nels for average value can't be changed.)	R/W
40203	2		R/W
40204	3		R/W
40205	Average Channel 0~3		R

*** AI Status (2 Registers)**

Lower Register		Higher Register	
Bit	Description	Bit	Description
0	Fail to Provide AI Value	0	DI triggered to Safety Value
1	Over Range	1	DI triggered to Startup Value
2	Under Range	2	Reserved
3	Open Circuit / Burnout	3	Reserved
4	Reserved	4	Reserved
5	Unavailable Channel Configuration	5	Reserved
6	Reserved	6	Reserved
7	ADC Initializing/Error	7	Reserved
8	Reserved	8	Reserved
9	Zero/Span Calibration Error	9	Reserved
10	Reserved	10	Reserved
11	Reserved	11	Reserved
12	Reserved	12	Reserved
13	Reserved	13	Reserved
14	Reserved	14	Reserved
15	Reserved	15	Reserved

**** AI Type Code (2 Registers)**

Input Type	Input Range	Type Code
Unipolar Voltage	0~10 V	0x0148
	0~5 V	0x0147
	0~1 V	0x0145
	0~500m V	0x0106
	0~150m V	0x0105
Bipolar Voltage	+/-10V	0x0143
	+/-5V	0x0142
	+/-1V	0x0140
	+/-500mV	0x0104
	+/-150mV	0x0103
Current	0~20mA	0x0182
	4~20mA	0x0180
	+/-20mA	0x0181
DI Mode	DI	0x01E0

A.7 WISE-4050 Wireless Modbus Mapping Table

Address 0X	Channel	Description	Attribute
00001	0		Read
00002	1	DI Value	Read
00003	2		Read
00004	3		Read
00017	0		
00018	1	DO Value	R/W
00019	2		R/W
00020	3		R/W
00033	0		
00034	1	Counter Status (0: stop 1: start)	R/W
00035	2		R/W
00036	3		R/W
00037	0		
00038	1	Clear Counter (1: write to clear value)	Write
00039	2		Write
00040	3		Write
00041	0		
00042	1	Clear Overflow (1: counter overflow, auto set to 0 after read)	R/W
00043	2		R/W
00044	3		R/W
00045	0		
00046	1	DI Latch Status (1: DI latched, 0: write to clear latch)	R/W
00047	2		R/W
00048	3		R/W
Address 4X	Channel	Description	Attribute
40211	-	Module Name 1	Read
40212	-	Module Name 2	Read
40301	All DI	DI Value	Read
40303	All DO	DO Value	R/W
40001~40002	0		Read
40003~40004	1	Counter/Frequency Value	Read
40005~40006	2		Read
40007~40008	3		Read

40009~40010	0		R/W
40011~40012	1	Pulse Output	R/W
40013~40014	2	Low Level Width	R/W
40015~40016	3		R/W
40017~40018	0		R/W
40019~40020	1	Pulse Output	R/W
40021~40022	2	High Level Width	R/W
40023~40024	3		R/W
40025~40026	0		R/W
40027~40028	1	Set Absolute	R/W
40029~40030	2	Pulse Output Number	R/W
40031~40032	3	(0 for continuous output)	R/W
40033~40034	0		R/W
40035~40036	1	Set Incremental	R/W
40037~40038	2	Pulse Output Number	R/W
40039~40040	3		R/W

A.8 WISE-4051 Wireless Modbus Mapping Table

Address 0X	Channel	Description	Attribute
00001	0		Read
00002	1		Read
00003	2		Read
00004	3	DI Value	Read
00005	4		Read
00006	5		Read
00007	6		Read
00008	7		Read
<hr/>			
00033	0		R/W
00034	1		R/W
00035	2		R/W
00036	3	Counter Status (0: stop 1: start)	R/W
00037	4		R/W
00038	5		R/W
00039	6		R/W
00040	7		R/W
<hr/>			
00041	0		Write
00042	1		Write
00043	2		Write
00044	3	Clear Counter (1: write to clear value)	Write
00045	4		Write
00046	5		Write
00047	6		Write
00048	7		Write
<hr/>			
00049	0		R/W
00050	1		R/W
00051	2		R/W
00052	3	Clear Overflow (1: counter overflow, auto set to 0 after read)	R/W
00053	4		R/W
00054	5		R/W
00055	6		R/W
00056	7		R/W
<hr/>			
	0		
00057	0		R/W
00058	1		R/W
00059	2		R/W
00060	3	DI Latch Status (1: DI latched, 0: write to clear latch)	R/W
00061	4		R/W
00062	5		R/W
00063	6		R/W
00064	7		R/W

01001~01032		Expansion Bit	R/W
05001		Low Battery Status	Read
<hr/>			
Address 4X	Channel	Description	Attribute
40211	-	Module Name 1	Read
40212	-	Module Name 2	Read
<hr/>			
40301	All DI	DI Value	Read
<hr/>			
40001~40002	0		R/W
40003~40004	1		R/W
40005~40006	2		R/W
40007~40008	3	Counter/Frequency Value	R/W
40009~40010	4		R/W
40011~40012	5		R/W
40013~40014	6		R/W
40015~40016	7		R/W
<hr/>			
41001~41032		Expansion Word	R/W
<hr/>			
41101~41132		Expansion Bit Error Code	Read
<hr/>			
41201~41232		Expansion Word Error Code	Read
<hr/>			
45101		Data Log Status	Read

A.9 WISE-4060 Wireless Modbus Mapping Table

Address 0X	Channel	Description	Attribute
00001	0		Read
00002	1	DI Value	Read
00003	2		Read
00004	3		Read
00017	0		R/W
00018	1	DO Value	R/W
00019	2		R/W
00020	3		R/W
00033	0	Counter Status (0: stop 1: start)	R/W
00034	1		R/W
00035	2		R/W
00036	3		R/W
00037	0	Clear Counter (1: write to clear value)	Write
00038	1		Write
00039	2		Write
00040	3		Write
00041	0	Clear Overflow (1: counter overflow, auto set to 0 after read)	R/W
00042	1		R/W
00043	2		R/W
00044	3		R/W
00045	0	DI Latch Status (1: DI latched, 0: write to clear latch)	R/W
00046	1		R/W
00047	2		R/W
00048	3		R/W
Address 4X	Channel	Description	Attribute
40211	-	Module Name 1	Read
40212	-	Module Name 2	Read
40301	All DI	DI Value	Read
40303	All DO	DO Value	R/W
40001~40002	0	Counter/Frequency Value	Read
40003~40004	1		Read
40005~40006	2		Read
40007~40008	3		Read

40009~40010	0		R/W
40011~40012	1	Pulse Output	R/W
40013~40014	2	Low Level Width	R/W
40015~40016	3		R/W
40017~40018	0		R/W
40019~40020	1	Pulse Output	R/W
40021~40022	2	High Level Width	R/W
40023~40024	3		R/W
40025~40026	0		R/W
40027~40028	1	Set Absolute	R/W
40029~40030	2	Pulse Output Number	R/W
40031~40032	3	(0 for continuous output)	R/W
40033~40034	0		R/W
40035~40036	1	Set Incremental	R/W
40037~40038	2	Pulse Output Number	R/W
40039~40040	3		R/W

Appendix **B**

REST for WISE-4000
Series

B.1 Introduction

REpresentational State Transfer (REST) is a design style of software architecture for Web application behaves and services including image indication, resource request and response and message delivery. It can be developed compatible with popular protocols or standards like HTTP, URI, JSON, HTML. With the advantage of scalability, simplicity and performance, it's already adopted in Web service by Amazon, Yahoo. The Web service of is developed based on HTML5 language, if user need to integrate this into other Web services, the following information/command list should be referred for implementation.

B.2 REST Resources for WISE-4000 Series

B.2.1 Digital Input

B.2.1.1 /di_value/slot_index/ch_num

Description	Retrieves information about the digital input value resource on specific slot.
URL Structure	http://10.0.0.1/di_value/slot_index http://10.0.0.1/di_value/slot_index/ch_num
HTTP Method	GET:Returns the representation of all of digital input value resource. PUT:Replace all of digital input value resource PATCH:Apply partial modifications to digital input value resource.

GET	<p>Multiple Channel Request: GET /di_value/slot_index Single Channel Request: GET /di_value/slot_index/ch_num</p> <p>[Example]</p> <p>Request: GET /di_value/slot_0</p> <p>Content-type: application/json Response: 200 OK</p> <pre>{ "DIVal": [{ "Ch":0, "Md":0, "Stat":1, "Val":1, "Cnting":0, "ClrCnt":0, "OvLch": 0 }, { "Ch":1, "Md":0, "Stat":0, "Val":0, "Cnting":0, "ClrCnt":0, "OvLch": 0 }, { "Ch":2, "Md":1, "Stat":0, "Val":3378, "Cnting":1, "ClrCnt":0, "OvLch": 0 }, { "Ch":3, "Md":3, "Stat":0, "Val":1, "Cnting":0, "ClrCnt":0, "OvLch": 0 }] }</pre> <p>Request : GET /di_value/slot_0/ch_2</p> <p>Content-type: application/json Response: 200 OK</p> <pre>{ "Ch":2, "Md":0, "Stat":1, "Val":1, "Cnting":0, "ClrCnt":0, "OvLch": 0 }</pre>
-----	---

PUT	<p>Single/Multiple Channel Request: PUT /di_value/slot_index Single Channel Request: PUT /di_value/slot_index/ch_num</p> <p>[Example]</p> <p>Request: PUT /di_value/slot_0</p> <p>Content-type: application/json</p> <pre>{ "DlVal": [{ "Ch":0, "Md":0, "Stat":0, "Val":0, "Cnting":0, "ClrCnt":0, "OvLch": 0 }, { "Ch":1, "Md":0, "Stat":0, "Val":0, "Cnting":0, "ClrCnt":0, "OvLch": 0 }, { "Ch":2, "Md":1, "Stat":0, "Val":3378, "Cnting":0, "ClrCnt":1, "OvLch": 0 }, { "Ch":3, "Md":3, "Stat":0, "Val":0, "Cnting":0, "ClrCnt":0, "OvLch": 0 }] }</pre> <p>Response: 200 OK</p> <p>Request: PUT /di_value/slot_0/ch_2</p> <p>Content-type: application/json</p> <pre>{ "Ch":2, "Md":1, "Stat":0, "Val":3378, "Cnting":0, "ClrCnt":1, "OvLch": 0 }</pre> <p>Response: 200 OK</p>
-----	--

PATCH	<p>Single/Multiple Channel Request: PATCH /di_value/slot_index</p> <p>Single Channel Request: PATCH /di_value/slot_index/ch_num</p> <p>[Example]</p> <p>Request: PATCH /di_value/slot_0</p> <p>Content-type: application/json</p> <pre>{ "DlVal": [{ "Ch":2, "Cnting": 1 }, { "Ch":3, "OvLch":0 }] }</pre> <p>Response: 200 OK</p> <p>Request: PATCH /di_value/slot_0/ch_3</p> <p>Content-type: application/json</p> <pre>{ "Ch":3, "ClrCnt":1 }</pre> <p>Response: 200 OK</p>
-------	---

■ JSON array name definition:

Field	Abbreviation	Data Type
Array of Digital input configurations	DlVal	Array

■ Resource value definitions:

Field	Abbreviation	Data Type	Property	Description
Channel Number	Ch	Number	R	0, 1, ...: Digital input channel number. Digital input mode.
Mode	Md	Number	R	0 DI
				1 Counter
				2 LowToHighLatch
				3 HighToLowLatch
				4 Frequency
Signal Logic Status	Stat	Number	R	1, 0: Input signal is Logic High or Low. DI measurement data
Channel Value	Val	Number	R	Input Mode Value Description
				DI Logic Status of DI
				Counter Counter Value
				LowToHighLatch Logic status of DI
				HighToLowLatch Logic status of DI
				Frequency Frequency(unity 0.1 Hz)
Start Counter	Cnting	Number	RW	Start/Stop counter counting Read 1 : counter is counting 0 : not counting Write 1 : start counting 0 : stop counting
Clear Counter	ClrCnt	Number	W	1 : Clear the counter value
Get/Clear Counter Overflow or Latch Status	OvLch	Number	RW	counter overflow or latch status Read 1 : overflow/latch occurred. 0 : no overflow or latch Write 0 : clear the overflow or latch status

B.2.2 Digital Output

B.2.2.1 /do_value/slot_index/ch_num

Description	Retrieves information about the digital output value resource on specific slot.
URL Structure	http://10.0.0.1/do_value/slot_index http://10.0.0.1/do_value/slot_index/ch_num
HTTP Method	GET:Returns the representation of all of digital output value resource. PUT:Replace all of digital output value resource PATCH:Apply partial modifications to digital output value resource.

GET	<p>Multiple Channel Request: GET /do_value/slot_index Single Channel Request: GET /do_value/slot_index/ch_num</p> <p>[Example]</p> <p>Request: GET /do_value/slot_0</p> <p>Content-type: application/json Response: 200 OK</p> <pre>{ "DOVal": [{ "Ch":0, "Md":0, "Stat":1, "Val":1, "PsCtn":0, "PsStop":0, "PsIV": 0 }, { "Ch":1, "Md":0, "Stat":0, "Val":0, "PsCtn":0, "PsStop":0, "PsIV": 0 }, { "Ch":2, "Md":1, "Stat":1, "Val":3378, "PsCtn":0, "PsStop":0, "PsIV": 0 }, { "Ch":3, "Md":3, "Stat":1, "Val":1, "PsCtn":0, "PsStop":0, "PsIV": 0 }] }</pre> <p>Request : GET /do_value/slot_0/ch_2</p> <p>Content-type: application/json Response: 200 OK</p> <pre>{ "Ch":2, "Md":0, "Stat":1, "Val":1, "PsCtn":0, "PsStop":0, "PsIV": 0 }</pre>
-----	---

PUT	<p>Single/Multiple Channel Request: PUT /do_value/slot_index Single Channel Request: PUT /do_value/slot_index/ch_num</p> <p>[Example]</p> <p>Request: PUT /do_value/slot_0</p> <p>Content-type: application/json</p> <pre>{ "DOVal": [{ "Ch":0, "Md":0, "Stat":1, "Val":1, "PsCtn":0, "PsStop":0, "PsIV": 0 }, { "Ch":1, "Md":0, "Stat":0, "Val":0, "PsCtn":0, "PsStop":0, "PsIV": 0 }, { "Ch":2, "Md":1, "Stat":1, "Val":3378, "PsCtn":0, "PsStop":0, "PsIV": 0 }, { "Ch":3, "Md":3, "Stat":1, "Val":1, "PsCtn":0, "PsStop":0, "PsIV": 0 }] }</pre> <p>Response: 200 OK</p> <p>Request: PUT /do_value/slot_0/ch_2</p> <p>Content-type: application/json</p> <pre>{ "Ch":2, "Md":2, "Stat":0, "Val":0, "PsCtn":0, "PsStop":0, "PsIV": 0 }</pre> <p>Response: 200 OK</p>
-----	---

PATCH	<p>Single/Multiple Channel Request: PATCH /do_value/slot_index Single Channel Request: PATCH /do_value/slot_index/ch_num</p> <p>[Example]</p> <p>Request: PATCH /do_value/slot_0</p> <p>Content-type: application/json</p> <pre>{ "DOVal": [{ "Ch":2, "Md": 2 }, { "Ch":3, "PsStop":1 }] }</pre> <p>Response: 200 OK</p> <p>Request: PATCH /do_value/slot_0/ch_3</p> <p>Content-type: application/json</p> <pre>{ "Ch":3, "PsCtn":1 }</pre> <p>Response: 200 OK</p>
-------	---

■ JSON array name definition:

Field	Abbreviation	Data Type
Array of Digital input configurations	DOVal	Array

■ Resource value definitions:

Field	Abbreviation	Data Type	Property	Description
Channel Number	Ch	Number	R	0, 1, ...: Digital output channel number.
				Digital output mode.
				0 DO
				1 Pulse Output
				2 LowToHighDelay
				3 HighToLowDelay
Signal Logic Status	Stat	Number	R	1, 0: Output signal is Logic High or Low.
				DO measurement data Output Mode Value Description
				DO Get the current signal status or set its status
Channel Value	Val	Number	RW	Pulse Output Get or set the absolute pulse count value
				LowToHighDelay Get the current signal status or set its status
				HighToLowDelay Get the current signal status or set its status
Pulse Output Continue State	PsCtn	Number	RW	1 / 0: Pulse outputting is continuous or not.
Stop Pulse Output	PsStop	Number	W	1: Stop the pulse outputting. (Continue is disabled, Absolute and incremental values are reset to zero. DO signal status is set to logic low.)
Incremental Pulse Output Value	PsIV	Number	RW	Incremental Pulse Output Value

B.2.3 Analog Input

B.2.3.1 /ai_value/slot_index/ch_num

Description	Retrieves information about the analog input value resource on specific slot.
URL Structure	http://10.0.0.1/ai_value/slot_index http://10.0.0.1/ai_value/slot_index/ch_num
HTTP Method	GET:Returns the representation of all of analog input value resource. PUT:None PATCH:Apply partial modifications to analog input value resource.

GET	<p>Multiple Channel Request: GET /ai_value/slot_index Single Channel Request: GET /ai_value/slot_index/ch_num</p> <p>[Example]</p> <p>Request : GET /ai_value/slot_0</p> <p>Content-type: application/json Response: 200 OK</p> <pre>{ "AIVal": [{ "Ch":0, "En":1, "Rng":328, "Val":148, "Eg":650, "Evt":0, "LoA": 0, "HiA": 0, "HVal":190, "HEg":1250, "LVal":15, "LEg":500, "SVal":148, "ClrH": 0, "ClrL": 0 }, { "Ch":1, "En":1, "Rng":328, "Val":0, "Eg":0, "Evt":0, "LoA":0, "HiA":0, "HVal":0, "HEg":0, "LVal":0, "LEg":0, "SVal":0, "ClrH": 0, "ClrL": 0 }, { "Ch":2, "En":1, </pre>
-----	--

	<pre> "Rng":328, "Val":0, "Eg":0, "Evt":8, "LoA":0, "HiA":0, "HVal":0, "HEg":0, "LVal":0, "LEg":0, "SVAl":0, "CirH": 0, "CirL": 0 }, { "Ch":3, "En":1, "Rng":328, "Val":0, "Eg":0, "Evt":0, "LoA":0, "HiA":0, "HVal":0, "HEg":0, "LVal":0, "LEg":0, "SVAl":0, "CirH": 0, "CirL": 0 }, { "Ch":4, "En":1, "Rng":328, "Val":0, "Eg":0, "Evt":0, "LoA":0, "HiA":0, "HVal":0, "HEg":0, "LVal":0, "LEg":0, "SVAl":0, "CirH": 0, "CirL": 0 }] } Request : GET /ai_value/slot_0/ch_2 Content-type: application/json Response: 200 OK { "Ch":2, "En":1, "Rng":328, "Val":0, "Eg":0, "Evt":8, "LoA":0, "HiA":0, "HVal":0, "HEg":0, "LVal":0, "LEg":0, "SVAl":0, "CirH": 0, "CirL": 0 } </pre>
PUT	None

PATCH	<p>Single/Multi Channel Request: PATCH /ai_value/slot_index</p> <p>Single Channel Request: PATCH /ai_value/slot_index/ch_num</p> <p>[Example]</p> <p>Request: PATCH /ai_value/slot_0</p> <p>Content-type: application/json <pre>{ "AIVal": [{ "Ch":2, "LoA": 0 }, { "Ch":3, "HiA":0 }] }</pre></p> <p>Response: 200 OK</p> <p>Request: PATCH /ai_value/slot_0/ch_3</p> <p>Content-type: application/json <pre>{ "LoA":0 }</pre></p> <p>Response: 200 OK</p>
-------	--

■ JSON array name definition:

Field	Abbreviation	Data Type
Array of Analog input configurations	AIVal	Array

- Resource value definitions (Total channels = AI channel number + 1 average channel):

Field	Abbreviation	Data Type	Property	Description
Channel Number	Ch	Number	R	0, 1, ...: Analog input channel number. Note for the average channel: The average channel number for a 4-ch AI module is 4.
Input Range	Rng	Number	R	Analog input range.
				Range code
				328 (0x0148) 0 – 10 V
				259 (0x0103) +/- 150 mV
				260 (0x0104) +/- 500 mV
				320 (0x0140) +/- 1 V
				321 (0x0141) +/- 2.5 V
				322 (0x0142) +/- 5 V
				323 (0x0143) +/- 10 V
				327 (0x0147) 0 ~ 5 V
				384 (0x0180) 4 ~ 20 mA
				385 (0x0181) +/- 20 mA
				386 (0x0182) 0 ~ 20 mA
				65535 Invalid range, if average channel is disable
Channel Enable	En	Number	R	1 / 0: Enable / Disable AI conversion Notice: Average channel is read only. When channel mask of average is not 0, the value is 1.
Channel Raw Value	Val	Number	R	0 ~ 65535: AI measurement data (Raw data)
Channel Engineering data	Eg	Number	R	AI engineering data, the value is 1/1000 scale. For example, 1630 → 1.63
Channel Event Status	Evt	Number	R	AI statuses
Low Alarm Status	LoA	Number	RW	Low alarm status Read 1 : low alarm occurred. 0 : not occurred Write 0 : clear the low alarm status
				High alarm status Read 1 : high alarm occurred. 0 : not occurred Write 0 : clear the high alarm status
Maximum AI Raw Value	HVal	Number	R	AI max. measurement data (Raw data)

Maximum AI Engineering data	HEg	Number	R	AI max. engineering data, the value is 1/1000 scale For example, 10200→10.2
Minimum AI Raw Value	LVal	Number	R	AI min. measurement data (Raw data)
Minimum AI Engineering data	LEg	Number	R	AI min. engineering data, the value is 1/1000 scale For example, 250 → 0.25
Channel Raw Value After Scaling	SVal	Number	R	0 ~ 65535 : AI measurement data (Raw data) after scaling
Clear Maximum AI Value	ClrH	Number	W	1 : Clear the Maximum AI value
Clear Minimum AI Value	ClrL	Number	W	1 : Clear the Minimum AI value
Physical value after scaling	PEg	Number	R	AI physical value after scaling, the value is 1/1000 scale For example: 150350'150.35
Mapping unit	Uni	String	R	Unit for mapping value Max. 32 characters

*** AI Status (2 Registers)**

Lower Register		Higher Register	
Bit	Description	Bit	Description
0	Fail to Provide AI Value	0	DI triggered to Safety Value
1	Over Range	1	DI triggered to Startup Value
2	Under Range	2	Reserved
3	Open Circuit / Burnout	3	Reserved
4	Reserved	4	Reserved
5	Unavailable Channel Configuration	5	Reserved
6	Reserved	6	Reserved
7	ADC Initializing/Error	7	Reserved
8	Reserved	8	Reserved
9	Zero/Span Calibration Error	9	Reserved
10	Reserved	10	Reserved
11	Reserved	11	Reserved
12	Reserved	12	Reserved
13	Reserved	13	Reserved
14	Reserved	14	Reserved
15	Reserved	15	Reserved

B.2.4 RS-485 Port Expansion Data

B.2.4.1 Expansion Bit Data

/expansion_bit/com_x/ch_num

Description	Retrieves information about the expansion tag bit data resource, the data information is defined by user configuration
URL Structure	http://10.0.0.1/expansion_bit/com_x http://10.0.0.1/expansion_bit/com_x/ch_num where x = 1 ~ : the identifier of COM number where num = 0 ~ : the channel number
HTTP Method	GET: Returns the representation of all of expansion bit data resource. PUT: None PATCH: Apply partial modifications to expansion bit data resource.

GET	<p>Multi-Channel Request? GET /expansion_bit/com_x Single Channel Request? GET /expansion_bit/com_x/ch_num</p> <p>[Example]: ■ Request : GET /expansion_bit/com_1/</p> <p>Content-type: application/json Response: 200 OK</p> <pre>{ "ExpBit": [{ "Ch":0, "Val":1, "Evt":0, "SID":1, "Addr":1, "MAddr":1001, "WEvt":0 }, { "Ch":1, "Val":0, "Evt":0, "SID":1, "Addr":2, "MAddr":1002, "WEvt":0 }, { "Ch":2, "Val":1, "Evt":0, "SID":1, "Addr":3, "MAddr":1003, "WEvt":0 }, { "Ch":3, "Val":1, "Evt":0, "SID":1, "Addr":4, "MAddr":1004, "WEvt":0 }, { "Ch":4, "Val":1, "Evt":0, "SID":2, "Addr":1, "MAddr":1005, "WEvt":0 }, ] }</pre> <p>■ Request : GET /expansion_bit/com_1/ch_2</p> <p>Content-type: application/json Response: 200 OK</p> <pre>{ "Ch":2, "Val":1, "Evt":0, "SID":1, "Addr":3, "MAddr":1003, "WEvt":0 }</pre>
-----	--

JSON array name definition:																																																
Field	Abbreviation	Data Type																																														
Array of Analog input configurations	ExpBit	Array																																														
Resource value definitions:																																																
Field	Abbreviations	Data type	Property	Description																																												
Channel Number	Ch	Number	R	0, 1, ...: expansion tag data channel number																																												
Channel Value	Val	Number	R/W	The channel value of expansion tag data Value: 0/1 *After writing action, user must poll the "expansion bit writing status" to get process result																																												
Channel Error Code	Evt	Number	R	The channel error code of expansion tag data (TBD) Modbus exception code Bit 7: Write only mask <table border="1"> <thead> <tr> <th>Event Value (Bit: 6~0)</th> <th>Description</th> </tr> </thead> <tbody> <tr><td>0 (0x00)</td><td>No error</td></tr> <tr><td>1 (0x01)</td><td>Illegal function</td></tr> <tr><td>2 (0x02)</td><td>Illegal data address</td></tr> <tr><td>3 (0x03)</td><td>Illegal data value</td></tr> <tr><td>4 (0x04)</td><td>Slave device failure</td></tr> <tr><td>5 (0x05)</td><td>Acknowledge</td></tr> <tr><td>6 (0x06)</td><td>Slave device busy</td></tr> <tr><td>7 (0x07)</td><td>Negative acknowledge</td></tr> <tr><td>8(0x08)</td><td>Memory parity error</td></tr> <tr><td>9 (0x09)</td><td>Reserved</td></tr> <tr><td>10 (0x0A)</td><td>Gateway path unavailable</td></tr> <tr><td>11 (0x0B)</td><td>Gateway target device failed to respond</td></tr> <tr><td>12 ~15</td><td>Reserved</td></tr> <tr><td>16 (0x10)</td><td>Unavailable</td></tr> <tr><td>17 (0x11)</td><td>Slave response timeout</td></tr> <tr><td>18 (0x12)</td><td>Checksum error</td></tr> <tr><td>19 (0x13)</td><td>Reserved data error</td></tr> <tr><td>20 (0x14)</td><td>Send request fail</td></tr> <tr><td>21 (0x15)</td><td>Unprocessed</td></tr> <tr><td>22 (0x16)</td><td>Read only</td></tr> <tr><td>23 (0x17)</td><td>In processing</td></tr> </tbody> </table>	Event Value (Bit: 6~0)	Description	0 (0x00)	No error	1 (0x01)	Illegal function	2 (0x02)	Illegal data address	3 (0x03)	Illegal data value	4 (0x04)	Slave device failure	5 (0x05)	Acknowledge	6 (0x06)	Slave device busy	7 (0x07)	Negative acknowledge	8(0x08)	Memory parity error	9 (0x09)	Reserved	10 (0x0A)	Gateway path unavailable	11 (0x0B)	Gateway target device failed to respond	12 ~15	Reserved	16 (0x10)	Unavailable	17 (0x11)	Slave response timeout	18 (0x12)	Checksum error	19 (0x13)	Reserved data error	20 (0x14)	Send request fail	21 (0x15)	Unprocessed	22 (0x16)	Read only	23 (0x17)	In processing
Event Value (Bit: 6~0)	Description																																															
0 (0x00)	No error																																															
1 (0x01)	Illegal function																																															
2 (0x02)	Illegal data address																																															
3 (0x03)	Illegal data value																																															
4 (0x04)	Slave device failure																																															
5 (0x05)	Acknowledge																																															
6 (0x06)	Slave device busy																																															
7 (0x07)	Negative acknowledge																																															
8(0x08)	Memory parity error																																															
9 (0x09)	Reserved																																															
10 (0x0A)	Gateway path unavailable																																															
11 (0x0B)	Gateway target device failed to respond																																															
12 ~15	Reserved																																															
16 (0x10)	Unavailable																																															
17 (0x11)	Slave response timeout																																															
18 (0x12)	Checksum error																																															
19 (0x13)	Reserved data error																																															
20 (0x14)	Send request fail																																															
21 (0x15)	Unprocessed																																															
22 (0x16)	Read only																																															
23 (0x17)	In processing																																															
Slave ID	SID	Number	R	Modbus RTU slave ID 0~255																																												
Slave Modbus Address	Addr	Number	R	Modbus RTU Slave device polling address: 1-9999																																												
Modbus TCP Mapping Address	MAddr	Number	R	Modbus TCP mapping address of expansion value:1-9999																																												

Field	Abbreviations	Data type	Property
-------	---------------	-----------	----------

The status for preview writing action.

Field	Abbreviations	Data type	Event Value (Bit: 6~0)	Description
			Expansion bit writing status	WEvt
			0 (0x00)	No error
			1 (0x01)	Illegal function
			2 (0x02)	Illegal data address
			3 (0x03)	Illegal data value
			4 (0x04)	Slave device failure
			5 (0x05)	Acknowledge
			6 (0x06)	Slave device busy
			7 (0x07)	Negative acknowledge
			8(0x08)	Memory parity error
			9 (0x09)	Reserved
			10 (0x0A)	Gateway path unavailable
			11 (0x0B)	Gateway target device failed to respond
			12 ~15	Reserved
			16 (0x10)	Unavailable
			17 (0x11)	Slave response timeout
			18 (0x12)	Checksum error
			19 (0x13)	Reserved data error
			20 (0x14)	Send request fail
			21 (0x15)	Unprocessed
			22 (0x16)	Read only
			23 (0x17)	In processing

*Event value 0x17: the writing process is not finish, user should poll the status later.

Remarks:

B.2.4.2 Expansion Word Data**/expansion_word/com_x/ch_num**

Description	Retrieves information about the expansion tag bit data resource, the data information is defined by user configuration
URL Structure	http://10.0.0.1/expansion_word/com_x http://10.0.0.1/expansion_word/com_x/ch_num where x = 1 ~ : the identifier of COM number where num = 0 ~ : the channel number
HTTP Method	GET: Returns the representation of all of expansion bit data resource. PUT: None PATCH: Apply partial modifications to expansion bit data resource.

GET	<p>Multi-Channel Request? GET /expansion_word/com_x Single Channel Request? GET /expansion_word/com_x/ch_num</p> <p>[Example]:</p> <p>■ Request : GET /expansion_word/com_1</p> <p>Content-type: application/json Response: 200 OK</p> <pre>{ "ExpWord": [{ "Ch":0, "Val":32768, "Evt":0, "SID":1, "Addr":1, "MAddr":1001, "WEvt":0 }, { "Ch":1, "Val":1235, "Evt":0, "SID":1, "Addr":2, "MAddr":1002, "WEvt":0 }, { "Ch":2, "Val":65535, "Evt":0, "SID":1, "Addr":3, "MAddr":1003, "WEvt":0 }, { "Ch":3, "Val":33358, "Evt":0, "SID":1, "Addr":4, "MAddr":1004, "WEvt":0 }, { "Ch":4, "Val":4095, "Evt":0, "SID":2, "Addr":211, "MAddr":1005, "WEvt":0 }, { "Ch":31, "Val":0, "Evt":0, "SID":3, "Addr":1, "MAddr":1032, "WEvt":0 }] }</pre> <p>■ Request : GET /expansion_word/com_1/ch_2</p> <p>Content-type: application/json Response: 200 OK</p> <pre>{ "Ch":2, "Val":65535, "Evt":0, "SID":1, "Addr":3, "MAddr":1003, "WEvt":0 }</pre>
-----	---

JSON array name definition:																																																
Field	Abbreviation	Data Type																																														
Array of Analog input configurations	ExpWord	Array																																														
Resource value definitions:																																																
Field	Abbreviations	Data type	Property	Description																																												
Channel Number	Ch	Number	R	0, 1, ...: expansion tag data channel number																																												
Channel Value	Val	Number	R/W	The channel value of expansion tag data Value: 0/1 *After writing action, user must poll the "expansion bit writing status" to get process result																																												
Channel Error Code	Evt	Number	R	The channel error code of expansion tag data (TBD) Modbus exception code Bit 7: Write only mask <table border="1"> <thead> <tr> <th>Event Value (Bit: 6~0)</th> <th>Description</th> </tr> </thead> <tbody> <tr><td>0 (0x00)</td><td>No error</td></tr> <tr><td>1 (0x01)</td><td>Illegal function</td></tr> <tr><td>2 (0x02)</td><td>Illegal data address</td></tr> <tr><td>3 (0x03)</td><td>Illegal data value</td></tr> <tr><td>4 (0x04)</td><td>Slave device failure</td></tr> <tr><td>5 (0x05)</td><td>Acknowledge</td></tr> <tr><td>6 (0x06)</td><td>Slave device busy</td></tr> <tr><td>7 (0x07)</td><td>Negative acknowledge</td></tr> <tr><td>8(0x08)</td><td>Memory parity error</td></tr> <tr><td>9 (0x09)</td><td>Reserved</td></tr> <tr><td>10 (0x0A)</td><td>Gateway path unavailable</td></tr> <tr><td>11 (0x0B)</td><td>Gateway target device failed to respond</td></tr> <tr><td>12 ~15</td><td>Reserved</td></tr> <tr><td>16 (0x10)</td><td>Unavailable</td></tr> <tr><td>17 (0x11)</td><td>Slave response timeout</td></tr> <tr><td>18 (0x12)</td><td>Checksum error</td></tr> <tr><td>19 (0x13)</td><td>Reserved data error</td></tr> <tr><td>20 (0x14)</td><td>Send request fail</td></tr> <tr><td>21 (0x15)</td><td>Unprocessed</td></tr> <tr><td>22 (0x16)</td><td>Read only</td></tr> <tr><td>23 (0x17)</td><td>In processing</td></tr> </tbody> </table>	Event Value (Bit: 6~0)	Description	0 (0x00)	No error	1 (0x01)	Illegal function	2 (0x02)	Illegal data address	3 (0x03)	Illegal data value	4 (0x04)	Slave device failure	5 (0x05)	Acknowledge	6 (0x06)	Slave device busy	7 (0x07)	Negative acknowledge	8(0x08)	Memory parity error	9 (0x09)	Reserved	10 (0x0A)	Gateway path unavailable	11 (0x0B)	Gateway target device failed to respond	12 ~15	Reserved	16 (0x10)	Unavailable	17 (0x11)	Slave response timeout	18 (0x12)	Checksum error	19 (0x13)	Reserved data error	20 (0x14)	Send request fail	21 (0x15)	Unprocessed	22 (0x16)	Read only	23 (0x17)	In processing
Event Value (Bit: 6~0)	Description																																															
0 (0x00)	No error																																															
1 (0x01)	Illegal function																																															
2 (0x02)	Illegal data address																																															
3 (0x03)	Illegal data value																																															
4 (0x04)	Slave device failure																																															
5 (0x05)	Acknowledge																																															
6 (0x06)	Slave device busy																																															
7 (0x07)	Negative acknowledge																																															
8(0x08)	Memory parity error																																															
9 (0x09)	Reserved																																															
10 (0x0A)	Gateway path unavailable																																															
11 (0x0B)	Gateway target device failed to respond																																															
12 ~15	Reserved																																															
16 (0x10)	Unavailable																																															
17 (0x11)	Slave response timeout																																															
18 (0x12)	Checksum error																																															
19 (0x13)	Reserved data error																																															
20 (0x14)	Send request fail																																															
21 (0x15)	Unprocessed																																															
22 (0x16)	Read only																																															
23 (0x17)	In processing																																															
Slave ID	SID	Number	R	Modbus RTU slave ID 0~255																																												
Slave Modbus Address	Addr	Number	R	Modbus RTU Slave device polling address: 1-9999																																												
Modbus TCP Mapping Address	MAddr	Number	R	Modbus TCP mapping address of expansion value:1-9999																																												

Field	Abbreviations	Data type	Property
-------	---------------	-----------	----------

The status for preview writing action.

Field	Abbreviations	Data type	Event Value (Bit: 6~0)	Description
			Expansion bit writing status	WEvt
			0 (0x00)	No error
			1 (0x01)	Illegal function
			2 (0x02)	Illegal data address
			3 (0x03)	Illegal data value
			4 (0x04)	Slave device failure
			5 (0x05)	Acknowledge
			6 (0x06)	Slave device busy
			7 (0x07)	Negative acknowledge
			8(0x08)	Memory parity error
			9 (0x09)	Reserved
			10 (0x0A)	Gateway path unavailable
			11 (0x0B)	Gateway target device failed to respond
			12 ~15	Reserved
			16 (0x10)	Unavailable
			17 (0x11)	Slave response timeout
			18 (0x12)	Checksum error
			19 (0x13)	Reserved data error
			20 (0x14)	Send request fail
			21 (0x15)	Unprocessed
			22 (0x16)	Read only
			23 (0x17)	In processing

*Event value 0x17: the writing process is not finish, user should poll the status later.

Remarks:

B.2.5 Data Logger

B.2.5.1 /log_message

Description	Retrieves the log data in system memory.
URL Structure	http://10.0.0.1/log_message
HTTP Method	GET: According to the setting of filtering, server returns the all/partial of logged data.
GET	<p>Request: GET /log_message</p> <p>[Example]: Request: GET /log_message for WISE-4060/LAN module</p> <p>Content-type: application/json Response: 200 OK</p> <pre>{ "LogMsg": [{ "PE":128, "TIM":"2014-11-11T15:48:32+08:00", "UID":"ADAM-4060/LAN_00D0C9FE1601", "MAC":"00-D0-C9-FE-16-01", "Record" : [[0,3,3,1], [0,2,4,150], [0,5,5,250]] }, { "PE":128, "TIM":"2014-11-11T15:49:44+08:00", "UID":"ADAM-4060/LAN_00D0C9FE1601", "MAC":"00-D0-C9-FE-16-01", "Record" : [[0,3,3,0], [0,2,4,140], [0,5,5,240]] }, { "PE":128, "TIM":"2014-11-11T15:51:02+08:00", "UID":"ADAM-4060/LAN_00D0C9FE1601", "MAC":"00-D0-C9-FE-16-01", "Record" : [[0,3,3,0], [0,2,4,130], [0,5,5,230]] }] }</pre>

JSON array name definition:

Field	Abbreviation	Data Type
Array of log messages	LogMsg	Array
Array of I/O records	Record	Array

Resource value definitions:

Field	Abbreviations	Data type	Property	Description												
Periodic/Event	128	Number	R	Recording mode of storage <table border="1"> <tr><td>1</td><td>DI</td></tr> <tr><td>2</td><td>DO</td></tr> <tr><td>4</td><td>Event from AI</td></tr> <tr><td>8</td><td>AO</td></tr> <tr><td>16</td><td>WDT</td></tr> <tr><td>128</td><td>Periodic</td></tr> </table>	1	DI	2	DO	4	Event from AI	8	AO	16	WDT	128	Periodic
1	DI															
2	DO															
4	Event from AI															
8	AO															
16	WDT															
128	Periodic															
Timestamp	TIM	String	R	Timestamp of the storage "Coordinated Universal Time (UTC) Ex. "1415757750" corresponds to November 12, 2014, 2:02:30 am, Standard Time. (meanwhile, 2014, 10:02:30 am, Taipei Time.) "Local Date/Time according GMT time zone (ISO 8601) Ex. "1994-11-05T08:15:30-05:00" corresponds to November 5, 1994, 8:15:30 am, US Eastern Standard Time.												
UUID	UID	String	R	Universally Unique Identifier (UUID) Max. 32 characters												
MAC ID	MAC	String	R	MAC address. (12+5) characters, ex, "00-D0-C9-F0-63-F7												

Recording message	Record	Array	R	<p>* The information in array is as follows. [Slot-index, Channel-index, I/O-type-index, I/O-value] * The data type in array is as follows. [Number, Number, Number, Number] Notice: When the I/O-type-index is engineering type (12, 13, 14, 18), the I/O value is 1/1000 scale.</p> <table border="1"> <thead> <tr> <th>Index</th> <th>Recording I/O-type of the storage</th> </tr> </thead> <tbody> <tr><td>0</td><td>Invalid</td></tr> <tr><td>1</td><td>DI Logic Status</td></tr> <tr><td>2</td><td>DI Counter value</td></tr> <tr><td>3</td><td>DI Frequency value</td></tr> <tr><td>4</td><td>DO Logic Status</td></tr> <tr><td>5</td><td>DO Absolute Pulse Output value</td></tr> <tr><td>6</td><td>DO Incremental Pulse Output Value</td></tr> <tr><td>7</td><td>AI value</td></tr> <tr><td>8</td><td>Historical Maximum AI value</td></tr> <tr><td>9</td><td>Historical Minimum AI value</td></tr> <tr><td>10</td><td>AI value after scaling</td></tr> <tr><td>11</td><td>AI status flags</td></tr> <tr><td>12</td><td>AI engineering value</td></tr> <tr><td>13</td><td>Historical Maximum AI engineering value</td></tr> <tr><td>14</td><td>Historical Minimum AI engineering value</td></tr> <tr><td>15</td><td>AO value</td></tr> <tr><td>16</td><td>AO value after scaling</td></tr> <tr><td>17</td><td>AO status flags</td></tr> <tr><td>18</td><td>AO engineering value</td></tr> <tr><td>19</td><td>AI physical value</td></tr> <tr><td>20</td><td>AI engineering value (floating type)</td></tr> <tr><td>21</td><td>Historical Maximum AI engineering value (floating type)</td></tr> <tr><td>22</td><td>Historical Minimum AI engineering value (floating type)</td></tr> <tr><td>23</td><td>AI physical value (floating tpye)</td></tr> <tr><td>30</td><td>Expansion bit data</td></tr> <tr><td>31</td><td>Expansion bit error code</td></tr> <tr><td>32</td><td>Expansion word data</td></tr> <tr><td>33</td><td>Expansion word error code</td></tr> </tbody> </table>	Index	Recording I/O-type of the storage	0	Invalid	1	DI Logic Status	2	DI Counter value	3	DI Frequency value	4	DO Logic Status	5	DO Absolute Pulse Output value	6	DO Incremental Pulse Output Value	7	AI value	8	Historical Maximum AI value	9	Historical Minimum AI value	10	AI value after scaling	11	AI status flags	12	AI engineering value	13	Historical Maximum AI engineering value	14	Historical Minimum AI engineering value	15	AO value	16	AO value after scaling	17	AO status flags	18	AO engineering value	19	AI physical value	20	AI engineering value (floating type)	21	Historical Maximum AI engineering value (floating type)	22	Historical Minimum AI engineering value (floating type)	23	AI physical value (floating tpye)	30	Expansion bit data	31	Expansion bit error code	32	Expansion word data	33	Expansion word error code
Index	Recording I/O-type of the storage																																																													
0	Invalid																																																													
1	DI Logic Status																																																													
2	DI Counter value																																																													
3	DI Frequency value																																																													
4	DO Logic Status																																																													
5	DO Absolute Pulse Output value																																																													
6	DO Incremental Pulse Output Value																																																													
7	AI value																																																													
8	Historical Maximum AI value																																																													
9	Historical Minimum AI value																																																													
10	AI value after scaling																																																													
11	AI status flags																																																													
12	AI engineering value																																																													
13	Historical Maximum AI engineering value																																																													
14	Historical Minimum AI engineering value																																																													
15	AO value																																																													
16	AO value after scaling																																																													
17	AO status flags																																																													
18	AO engineering value																																																													
19	AI physical value																																																													
20	AI engineering value (floating type)																																																													
21	Historical Maximum AI engineering value (floating type)																																																													
22	Historical Minimum AI engineering value (floating type)																																																													
23	AI physical value (floating tpye)																																																													
30	Expansion bit data																																																													
31	Expansion bit error code																																																													
32	Expansion word data																																																													
33	Expansion word error code																																																													
Remarks																																																														

www.advantech.com

Please verify specifications before quoting. This guide is intended for reference purposes only.

All product specifications are subject to change without notice.

No part of this publication may be reproduced in any form or by any means, electronic, photocopying, recording or otherwise, without prior written permission of the publisher.

All brand and product names are trademarks or registered trademarks of their respective companies.

© Advantech Co., Ltd. 2015