



PRECISION CLOCK GENERATOR OC-48 APPLICATIONS

IDT5T929

PRODUCT DISCONTINUATION NOTICE - LAST TIME BUY EXPIRES ON OCTOBER 28, 2014

FEATURES:

- Input frequency:
 - For SONET non-FEC: 19.44MHz, 38.88MHz, 77.76MHz, 155.52MHz, 311.04MHz, or 622.08MHz
 - For SONET FEC: 20.83MHz, 41.66MHz, 83.31MHz, 166.63MHz, 333.26MHz, or 666.52MHz
 - For 10GE copper: 19.53MHz, 39.06MHz, 78.125MHz, 156.25MHz, 312.5MHz, or 625MHz
 - For 10GE optical: 20.14MHz, 40.28MHz, 80.56MHz, 161.13MHz, 322.26MHz, or 644.53MHz
- Output frequency range selection
- 1x, 2x, 4x, 8x, 16x, and 32x outputs on QOUT
- Regenerated input clock on QREG
- Lock indicator
- Power-down mode
- LVPECL or LVDS outputs
- Two modes of output frequency range
 - Mode 0: QOUT range 155.5 - 166.6MHz. QREG is a regenerated version of the input clock.
 - Mode 1: QOUT range 622 - 666.5MHz. QREG is a regenerated version of the input clock frequency.
- Hitless switchover
- Differential LVPECL, LVDS, or single-ended LVTTTL input interface
- 2.375 - 3.465V core and I/O
- Available in VFQFPN package
- use Replacement part: 8T49N222B-dddNLGI

DESCRIPTION:

The IDT5T929 generates a high precision FEC (Forward Error Correction) or non-FEC source clock for SONET/SDH systems as well as a source clock for Gigabit Ethernet systems. This device also has clock regeneration capability: it creates a "clean" version of the clock input by using the internal oscillator to square the input clock's rising and falling edges and remove jitter. In the event that the main clock input fails, the device automatically locks to a backup reference clock using a hitless switchover mechanism.

This device detects loss of valid CLKIN and leaves the VCO of the PLL at the last valid frequency while an alternate input REFIN is selected. If CLKIN and REFIN are different frequencies, the multiplication factor will be adjusted to retain the same output frequency.

The IDT5T929 can act as a translator from a differential LVPECL, LVDS, or single-ended LVTTTL input to LVPECL or LVDS outputs. The IDT5T929-10 has LVDS outputs and the IDT5T929-30 has LVPECL outputs.

The two modes of output frequency range are controlled by the SELmode. When SELmode is high or low, the QOUT is a multiplied version of the input clock while QREG is a regenerated version of the input clock.

APPLICATIONS:

- Terabit routers
- Gigabit ethernet systems
- SONET / SDH systems
- Digital cross connects
- Optical transceiver modules

FUNCTIONAL BLOCK DIAGRAM

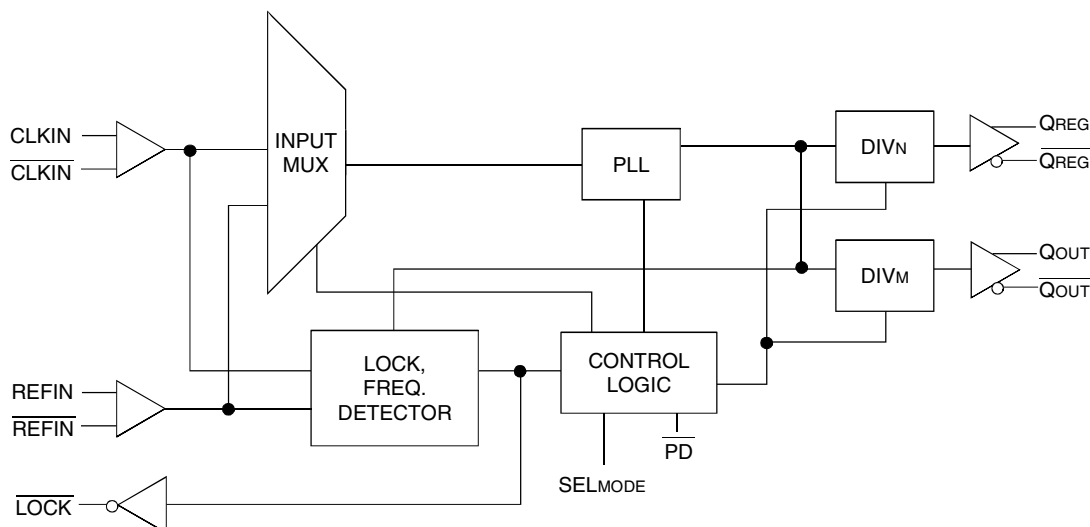

The IDT logo is a registered trademark of Integrated Device Technology, Inc.

INDUSTRIAL TEMPERATURE RANGE

MAY 2013

PIN CONFIGURATION

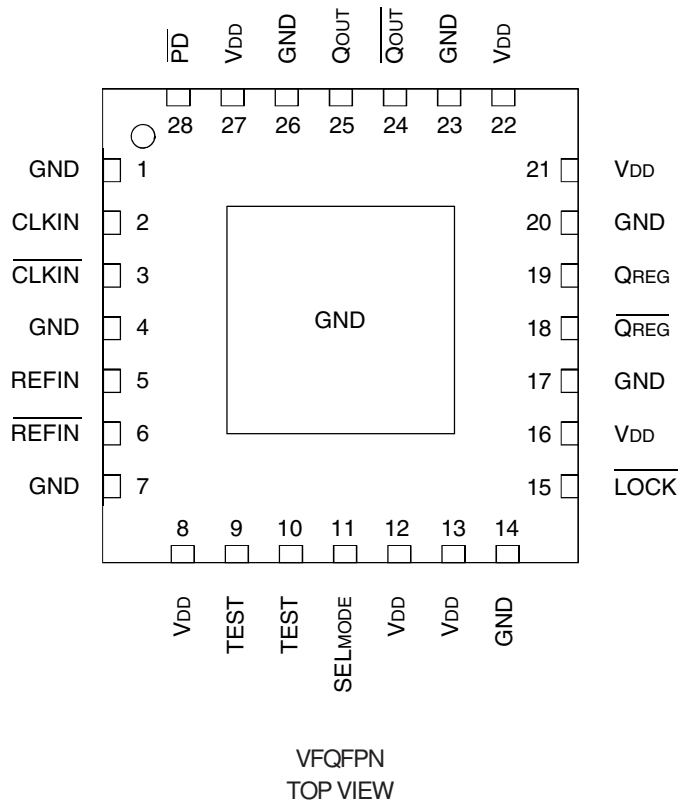

ABSOLUTE MAXIMUM RATINGS⁽¹⁾

Symbol	Description	Max	Unit
V _{DD}	Power Supply Voltage	-0.5 to +4.1	V
V _I	Input Voltage	-0.5 to +4.1	V
V _O	Output Voltage	-0.5 to V _{DD} +0.5	V
T _J	Junction Temperature	150	°C
T _{STG}	Storage Temperature	-65 to +165	°C

NOTE:

- Stresses beyond those listed under ABSOLUTE MAXIMUM RATINGS may cause permanent damage to the device. These are stress ratings only, and functional operation of the device at these or any other conditions above those indicated in the operational sections of this specification is not implied. Exposure to absolute-maximum-rated conditions for extended periods may affect device reliability.

CAPACITANCE_(T_A = +25°C, f = 1MHz, V_{IN} = 0V)

Parameter	Description	Typ.	Max.	Unit
C _{IN}	Input Capacitance	2.5	3	pF
C _{OUT}	Output Capacitance	—	—	pF

NOTE:

- Capacitance applies to all inputs except SELmode.

RECOMMENDED OPERATING RANGE

Symbol	Description	Min.	Typ.	Max.	Unit
T _A	Ambient Operating Temperature	-40	+25	+85	°C
V _{DD}	Power Supply Voltage	2.375	—	3.465	V
V _T	Termination Voltage (LVPECL)	—	V _{DD} -2	—	V
	Termination Voltage (LVDS)	—	1.2	—	

INPUT FREQUENCY RANGE⁽¹⁾

19.4MHz - 20.9MHz
38.8MHz - 41.7MHz
77.7MHz - 83.4MHz
155.5MHz - 167MHz
311MHz - 334MHz
622MHz - 667MHz

NOTE:

- The PLL will automatically detect the input frequency and adjust the multiply ratio to generate the appropriate output frequency.

LOCK FREQUENCY DETECTOR

The 5T929 will lock to, and track, a valid CLKIN signal; $\overline{\text{LOCK}}$ will be low when this has occurred. If CLKIN fails, the 5T929 PLL will smoothly switch to lock to REFIN without generating any glitches on the output. The fact that the PLL is locked to REFIN rather than CLKIN is indicated by a high state on $\overline{\text{LOCK}}$. When a valid input is then applied to CLKIN, the 5T929 will smoothly switch back to locking on CLKIN, and $\overline{\text{LOCK}}$ will go low. $\overline{\text{LOCK}}$ will also switch to high should the frequency of CLKIN drift close to the limits of the VCO tuning range.

OUTPUT FREQUENCY RANGE

SELmode	$Q_{\text{OUT}}/\overline{Q_{\text{OUT}}}$	$Q_{\text{REG}}/\overline{Q_{\text{REG}}}$	Unit
L	155.5 - 166.6	regenerated CLKIN/ $\overline{\text{CLKIN}}$	MHz
H	622 - 666.5	regenerated CLKIN/ $\overline{\text{CLKIN}}$	MHz

PIN DESCRIPTION

Pin Name	I/O	Type	Description
CLKIN, $\overline{\text{CLKIN}}$	I	Adjustable ⁽¹⁾	Differential or single-ended clock input signal. For differential, LVPECL or LVDS supported. If left open-circuited, inputs will float to LVTTTL threshold voltage so that either input may be used as a single-ended input. A capacitor to ground should be connected on the floating input.
REFIN, $\overline{\text{REFIN}}$	I	Adjustable ⁽¹⁾	Differential reference clock input. The reference clock input is used as an input to the PLL when CLKIN/ $\overline{\text{CLKIN}}$ fails. Differential or single-ended clock input signal. For differential, LVPECL or LVDS supported. If left open-circuited, inputs will float to LVTTTL threshold voltage so that either input may be used as a single-ended input. A capacitor to ground should be connected on the floating input.
SELmode	I	2-level ⁽²⁾	2 level input to select output frequency range for $Q_{\text{OUT}}/\overline{Q_{\text{OUT}}}$ and $Q_{\text{REG}}/\overline{Q_{\text{REG}}}$ (see Output Frequency Range table)
$\overline{\text{PD}}$	I	LVTTTL	Power Down Control. Shuts off entire chip when LOW.
$Q_{\text{OUT}}, \overline{Q_{\text{OUT}}}$	O	Adjustable ⁽³⁾	Differential clock output. LVPECL or LVDS outputs.
$Q_{\text{REG}}, \overline{Q_{\text{REG}}}$	O	Adjustable ⁽³⁾	Regenerated clock output from CLKIN/ $\overline{\text{CLKIN}}$, LVPECL, or LVDS outputs.
$\overline{\text{LOCK}}$	O	LVTTTL	LOW when PLL is locked to CLKIN, HIGH in all other conditions
TEST			Factory testing only. This pin should be left unconnected.
NC			No connection
V _{DD}		PWR	Power Supply
GND		PWR	Ground

NOTES:

- Inputs are capable of translating the following interface standards:
 - Single-ended 3.3V LVTTTL levels
 - Single-ended 2.5V LVTTTL levels
 - Differential LVPECL levels
 - Differential LVDS levels
- 2-level inputs are static inputs and must be tied to V_{DD} or GND.
- Outputs can be LVPECL or LVDS.

CLOCK INPUT/OUTPUT CONFIGURATION DESCRIPTION

Application	REFIN (MHz)	CKIN (MHz)	SELmode	QREG (MHz)	QOUT (MHz)		
Non-FEC	19.44, 38.88, 77.76, 155.52, 311.04, 622.08	19.44	LOW	19.44	155.52		
			HIGH	19.44	622.08		
		38.88	LOW	38.88	155.52		
			HIGH	38.88	622.08		
		77.76	LOW	77.76	155.52		
			HIGH	77.76	622.08		
		155.52	LOW	155.52	155.52		
			HIGH	155.52	622.08		
		311.04	LOW	311.04	155.52		
			HIGH	311.04	622.08		
		622.08	LOW	622.08	155.52		
			HIGH	622.08	622.08		
		FEC	20.83, 41.66, 83.31, 166.63, 333.26, 666.52	20.83	LOW	20.83	166.63
					HIGH	20.83	666.52
41.66	LOW			41.66	166.63		
	HIGH			41.66	666.52		
83.31	LOW			83.31	166.63		
	HIGH			83.31	666.52		
166.63	LOW			166.63	166.63		
	HIGH			166.63	666.52		
333.26	LOW			333.26	166.63		
	HIGH			333.26	666.52		
666.52	LOW			666.52	166.63		
	HIGH			666.52	666.52		
10GE copper	19.53, 39.06, 78.12, 156.25, 312.5, 625			19.53	LOW	19.53	156.25
					HIGH	19.53	625
		39.06	LOW	39.06	156.25		
			HIGH	39.06	625		
		78.12	LOW	78.12	156.25		
			HIGH	78.12	625		
		156.25	LOW	156.25	156.25		
			HIGH	156.25	625		
		312.5	LOW	312.50	156.25		
			HIGH	312.5	625		
		625	LOW	625	156.25		
			HIGH	625	625		
		10GE optical	20.14, 40.28, 80.56, 161.13, 322.26, 644.53	20.14	LOW	20.14	161.13
					HIGH	20.14	644.53
40.28	LOW			40.28	161.13		
	HIGH			40.28	644.53		
80.56	LOW			80.56	161.13		
	HIGH			80.56	644.53		
161.13	LOW			161.13	161.13		
	HIGH			161.13	644.53		
322.26	LOW			322.26	161.13		
	HIGH			322.26	644.53		
644.53	LOW			644.53	161.13		
	HIGH			644.53	644.53		

POWER SUPPLY CHARACTERISTICS^(1,2)

Symbol	Parameter	Test Conditions	Typ.	Max	Unit
I _{DD_PD}	Power Supply Current	V _{DD} = Max., \overline{PD} = GND, All outputs unloaded	—	50	μA
ΔI _{DD}	Power Supply Current per Input HIGH (LVTTTL inputs only)	V _{DD} = Max., V _{IN} = 2.375V	—	100	μA
I _{TOT}	Total Power Supply Current	V _{DD} = Max., Q _{OUT} = 622MHz, All outputs unloaded	—	200	mA

NOTES:

- These power consumption characteristics are for all the valid input interfaces and cover the worst case input and output interface combinations.
- As a general requirement, these parts must be capable of operating at the maximum frequency under a nominal load at a reasonable operating temperature. That means that these parts must not burn up under extended use in a typical application.

DC ELECTRICAL CHARACTERISTICS OVER OPERATING RANGE

Symbol	Parameter	Test Conditions	Min.	Max	Unit
V _{IHH}	Input HIGH Voltage Level ⁽¹⁾	2-Level Inputs Only	V _{DD} - 0.4	—	V
V _{ILL}	Input LOW Voltage Level ⁽¹⁾	2-Level Inputs Only	—	0.4	V
I ₂	2-Level Input DC Current	V _{IN} = V _{DD} HIGH Level	—	200	μA
		V _{IN} = GND LOW Level	-200	—	

- NOTE:
- These inputs are normally wired to V_{DD} or GND. If these inputs are switched dynamically after powerup, the function and timing of the outputs may be glitched, and the PLL may require additional t_{AO} time before all datasheet limits are achieved.

DC ELECTRICAL CHARACTERISTICS OVER OPERATING RANGE FOR LVTTTL

Symbol	Parameter	Test Conditions	Min.	Typ.	Max	Unit
I _{IH}	Input HIGH Current	V _{DD} = 3.465V	—	—	±1	μA
I _{IL}	Input LOW Current	V _{DD} = 3.465V	—	—	±1	
V _{IK}	Clamp Diode Voltage	V _{DD} = 2.375V, I _{IN} = -18mA	—	-0.7	-1.2	V
V _{IN}	DC Input Voltage		-0.3	—	+3.465	V
V _{IH}	DC Input HIGH		1.7	—	—	V
V _{IL}	DC Input LOW		—	—	0.7	V

DC ELECTRICAL CHARACTERISTICS OVER OPERATING RANGE FOR LVPECL⁽¹⁾

Symbol	Parameter	Test Conditions	Min.	Typ.	Max.	Unit
Input Characteristics						
I _{IN}	Input Current (CLKIN, REFIN)	V _{DD} = 3.465V	-20	—	+20	μA
V _{CMR}	Common Mode Input Voltage		1	—	V _{DD} - 0.3	V
V _{DIF}	Differential Voltage Required to Toggle Input		100	—	—	mV
Output Characteristics						
V _{OH}	Output Voltage HIGH (terminated through 50Ω tied to V _{DD} - 2V) ⁽²⁾		V _{DD} - 1.15	—	V _{DD} - 0.9	V
V _{OL}	Output Voltage LOW (terminated through 50Ω tied to V _{DD} - 2V) ⁽²⁾		V _{DD} - 1.95	—	V _{DD} - 1.61	V
V _{SWING}	Peak-to-Peak Output Voltage Swing		0.55	—	0.93	V

NOTES:

- V_{DD} = 2.375 - 3.645V.
- Not to exceed V_{DD} - 0.05V.

DC ELECTRICAL CHARACTERISTICS OVER OPERATING RANGE FOR LVDS

Symbol	Parameter	Test Conditions	Min.	Typ.	Max.	Unit
Input Characteristics						
I _{IN}	Input Current (CLKIN, REFIN)	V _{DD} = 3.465V	-20	—	+20	μA
V _{CM}	Common Mode Input Voltage Range ⁽¹⁾		0.9	—	V _{DD} - 0.05	V
V _{DIF}	Differential Voltage Required to Toggle Input		100	—	—	mV
Output Characteristics						
V _{OT(+)}	Differential Output Voltage for the TRUE Binary State		247	—	454	mV
V _{OT(-)}	Differential Output Voltage for the FALSE Binary State		-247	—	-454	mV
ΔV _{OT}	Change in V _{OT} Between Complementary Output States		—	—	50	mV
V _{OS}	Output Common Mode Voltage (Offset Voltage)		1.125	1.2	1.375	V
ΔV _{OS}	Change in V _{OS} Between Complementary Output States		—	—	50	mV
I _{OS}	Outputs Short Circuit Current	V _{OUT(+)} and V _{OUT(-)} = 0V	—	9	24	mA
I _{OSD}	Differential Outputs Short Circuit Current	V _{OUT(+)} = V _{OUT(-)}	—	6	12	mA

NOTE:

1. Not to exceed V_{DD} - 0.05V.

INPUT TIMING REQUIREMENTS

Symbol	Parameter	Min.	Typ.	Max.	Unit
REF _H	Input Reference Clock Duty Cycle	40	50	60	%
F _{REF}	Input Reference Clock Range	19.44	—	666.52	MHz
REF _{TOL}	Input Reference Clock Frequency Tolerance	-100	—	100	ppm
F _{CLKIN}	Clock in Frequency Range	19.44	—	666.52	MHz
CL _{KIN} _H	Clock in Duty Cycle	40	50	60	%
t _{ACQ}	Acquisition Time from Return of Valid CLKIN	—	60	150	us
LOCK _{TOL}	Frequency Tolerance for LOCK	-600	±450	600	ppm
t _{JIT(TOL)}	Tolerance to Input Jitter	GR-253 Sect. 5.6.2.2			

AC ELECTRICAL CHARACTERISTICS OVER OPERATING RANGE

Symbol	Parameter	Min.	Typ.	Max.	Unit	
Q _{OUT}	Multiplied Clock Output Frequency	SELmode = LOW	155.52	—	166.63	MHz
		SELmode = HIGH	622.08	—	666.52	
Q _{REG}	Regenerated Clock Output Frequency	19.44	—	666.52	MHz	
CL _{KIN}	Input Clock Frequency	19.44	—	667	MHz	
t _r	Output Rise Time	LVPECL	—	150	—	ps
		LVDS	—	100	—	
t _f	Output Fall Time	LVPECL	—	150	—	ps
		LVDS	—	100	—	
t _{SK}	Skew between Q _{OUT} and Q _{REG}	—	10	20	ps	
PLL _{BW}	PLL Bandwidth	250	305	500	KHz	
ƒ _p	Jitter Transfer Peaking	—	0.05	0.1	dB	
t _j	Jitter Generation ⁽¹⁾ (with 12KHz to 20MHz filter)	Output frequency = 622MHz - 666.5MHz	—	0.4	1	ps (RMS)
		Output frequency = 155.5MHz - 166.6MHz	—	0.8	3.4	
		Output frequency = 77.7MHz - 83.4MHz	—	1.2	3.5	
t _{OUTY}	Output Duty Cycle	45	—	55	%	

NOTE:

1. All input frequencies permitted by PLL bandwidth.

TEST CONDITIONS

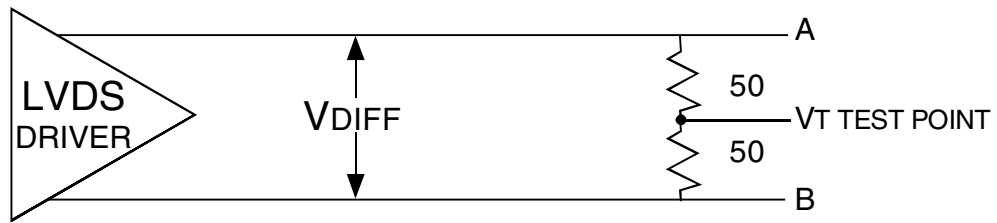

Test Circuit for LVDS Output Characteristics

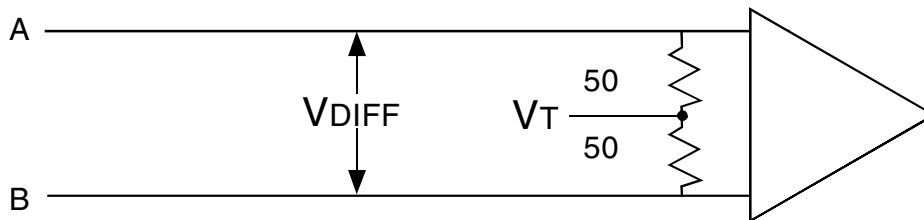

Test Circuit for LVDS Input Characteristics

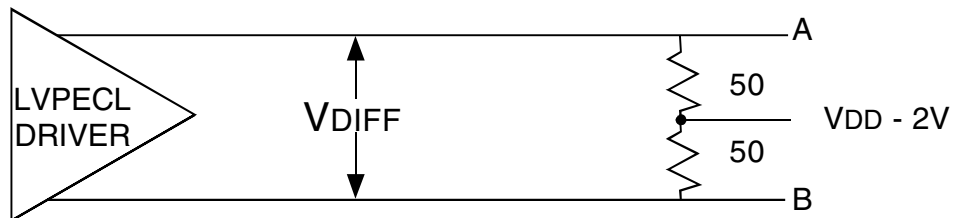

Test Circuit for LVPECL Output Characteristics

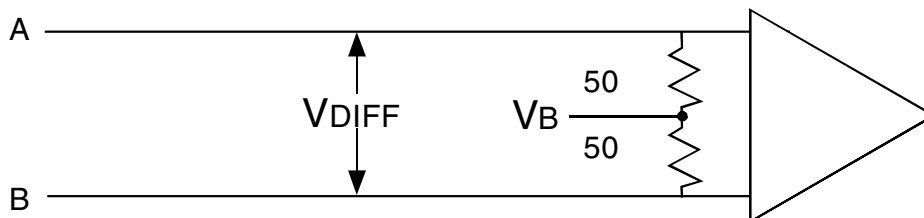

$$V_B = V_{DD} - 2V$$

Test Circuit for LVPECL Input Characteristics

RECOMMENDED LANDING PATTERN

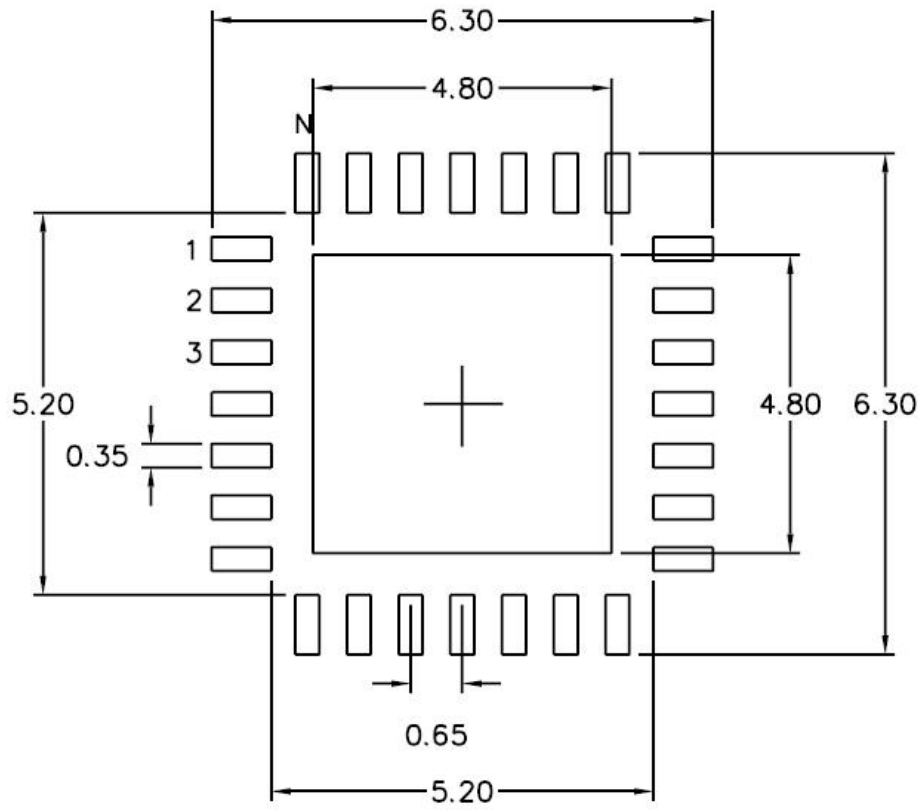

NL 28 pin

NOTE: All dimensions are in millimeters.

ORDERING INFORMATION

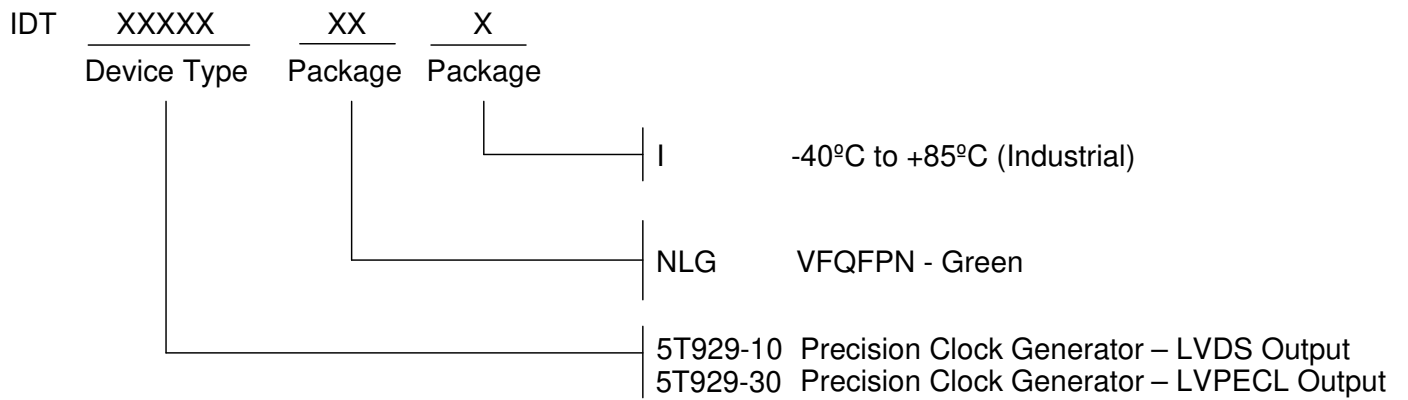

REVISION HISTORY

Rev	Table	Page	Discription of Change	Date
A		1	NRND - Not Recommended for New Designs	5/5/13
A		1	Product Discontinuation Notice - Last Time Buy Expires on October 28, 2014, PDN# CQ-13-02	11/27/13

We've Got Your Timing Solution.



6024 Silver Creek Valley Road
San Jose, CA 95138

Sales

800-345-7015 (inside USA)
+408-284-8200 (outside USA)
Fax: 408-284-2775
www.IDT.com/go/contactIDT

Tech Support

netcom@idt.com
+480-763-2056

DISCLAIMER Integrated Device Technology, Inc. (IDT) and its subsidiaries reserve the right to modify the products and/or specifications described herein at any time and at IDT's sole discretion. All information in this document, including descriptions of product features and performance, is subject to change without notice. Performance specifications and the operating parameters of the described products are determined in the independent state and are not guaranteed to perform the same way when installed in customer products. The information contained herein is provided without representation or warranty of any kind, whether express or implied, including, but not limited to, the suitability of IDT's products for any particular purpose, an implied warranty of merchantability, or non-infringement of the intellectual property rights of others. This document is presented only as a guide and does not convey any license under intellectual property rights of IDT or any third parties.

IDT's products are not intended for use in applications involving extreme environmental conditions or in life support systems or similar devices where the failure or malfunction of an IDT product can be reasonably expected to significantly affect the health or safety of users. Anyone using an IDT product in such a manner does so at their own risk, absent an express, written agreement by IDT.

Integrated Device Technology, IDT and the IDT logo are registered trademarks of IDT. Other trademarks and service marks used herein, including protected names, logos and designs, are the property of IDT or their respective third party owners.

Copyright 2013. All rights reserved.