

REVISIONS					
P	LTR	DESCRIPTION	DATE	DWN	APVD
AC		REVISED PER ECR-20-000721	04MAR2020	PC	SW

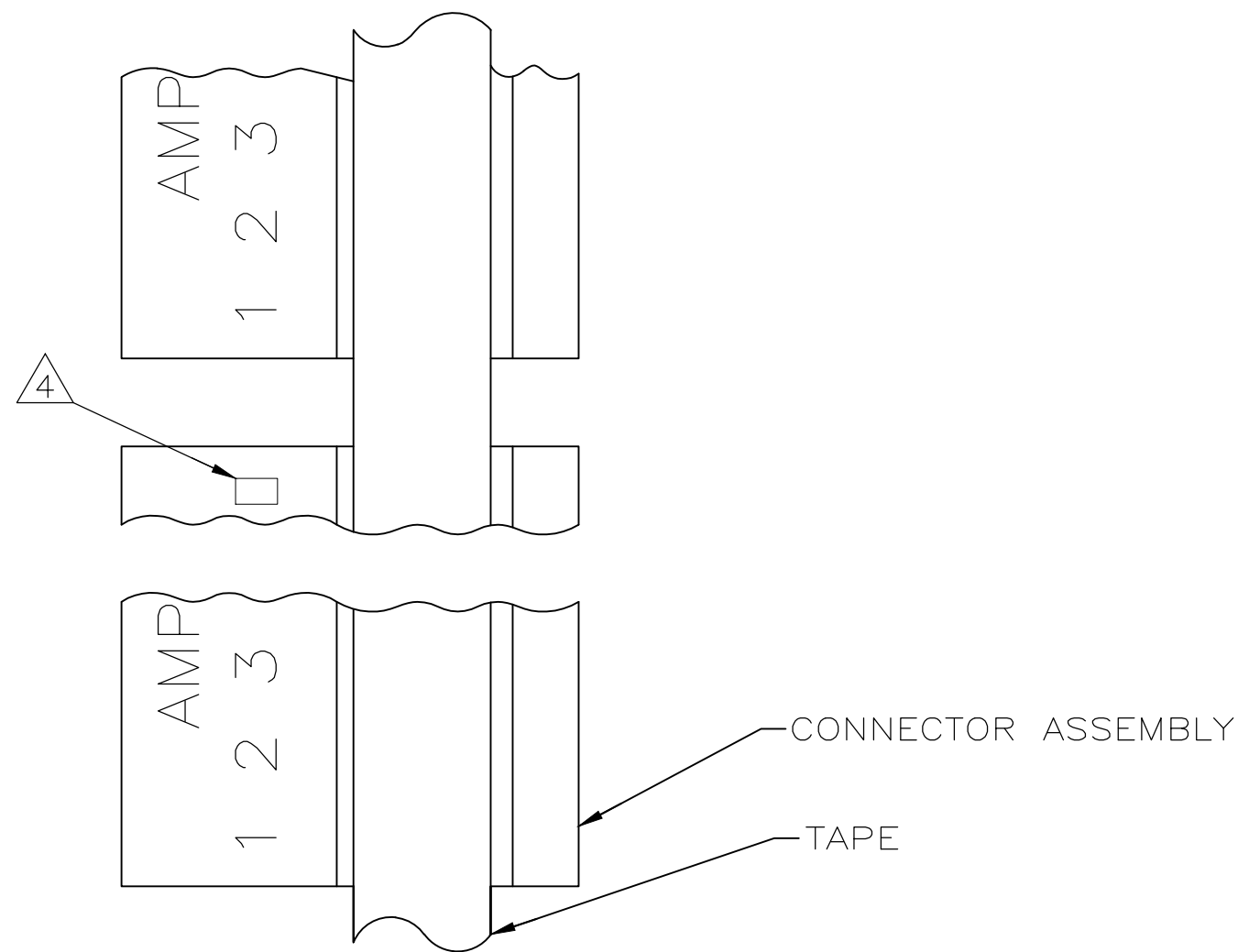

1 MATERIAL: CONNECTOR - NYLON UL94-V2 (WHITE)
 CONTACTS - 0.30[.012] THICK COPPER ALLOY
 BRIGHT TIN-LEAD 0.00203[.000080] MIN. THICK
 FOR CONTACTS 640469-2 THRU 2-640469-8.
 MATTE WHISKER MITIGATED TIN PLATE 0.00203[.000080] MIN.
 THICK OVER NICKEL UNDERPLATE FOR CONTACTS 3-640469-2
 THRU 5-640469-8.

2. CONTACTS ACCEPT 24 AWG WIRE WITH 1.52[.060] MAX INSULATION DIAMETER.
 3. CONTACTS MUST ACCEPT 0.64 ± 0.03[.025 ± .001] SQUARE POST AND REMAIN LOCKED IN POSITION.

4 IDENTIFICATION NUMBER FOR LAST CIRCUIT MAY NOT APPEAR ON ALL ASSEMBLIES.

5. DIMENSIONS IN BRACKETS ARE IN INCHES.

6. HOUSING FEATURES ARE: CLOSED END WITH LOCKING RAMP.

7 OBSOLETE PARTS: OBSOLETE CIS STREAMLINING PER D.RENAUD/D.SINISI

8 OBSOLETE PARTS

YES	71.12[2.800]	28	5-640469-8
YES	68.58[2.700]	27	5-640469-7
YES	66.04[2.600]	26	5-640469-6
YES	63.50[2.500]	25	5-640469-5
YES	60.96[2.400]	24	5-640469-4
YES	58.42[2.300]	23	5-640469-3
YES	55.88[2.200]	22	5-640469-2
YES	53.34[2.100]	21	5-640469-1
YES	50.80[2.000]	20	5-640469-0
YES	48.26[1.900]	19	4-640469-9
YES	45.72[1.800]	18	4-640469-8
YES	43.18[1.700]	17	4-640469-7
YES	40.64[1.600]	16	4-640469-6
YES	38.10[1.500]	15	4-640469-5
YES	35.56[1.400]	14	4-640469-4
YES	33.02[1.300]	13	4-640469-3
YES	30.48[1.200]	12	4-640469-2
YES	27.94[1.100]	11	4-640469-1
YES	25.40[1.000]	10	4-640469-0
YES	22.86[.900]	9	3-640469-9
YES	20.32[.800]	8	3-640469-8
YES	17.78[.700]	7	3-640469-7
YES	15.24[.600]	6	3-640469-6
YES	12.70[.500]	5	3-640469-5
YES	10.16[.400]	4	3-640469-4
YES	7.62[.300]	3	3-640469-3
YES	5.08[.200]	2	3-640469-2

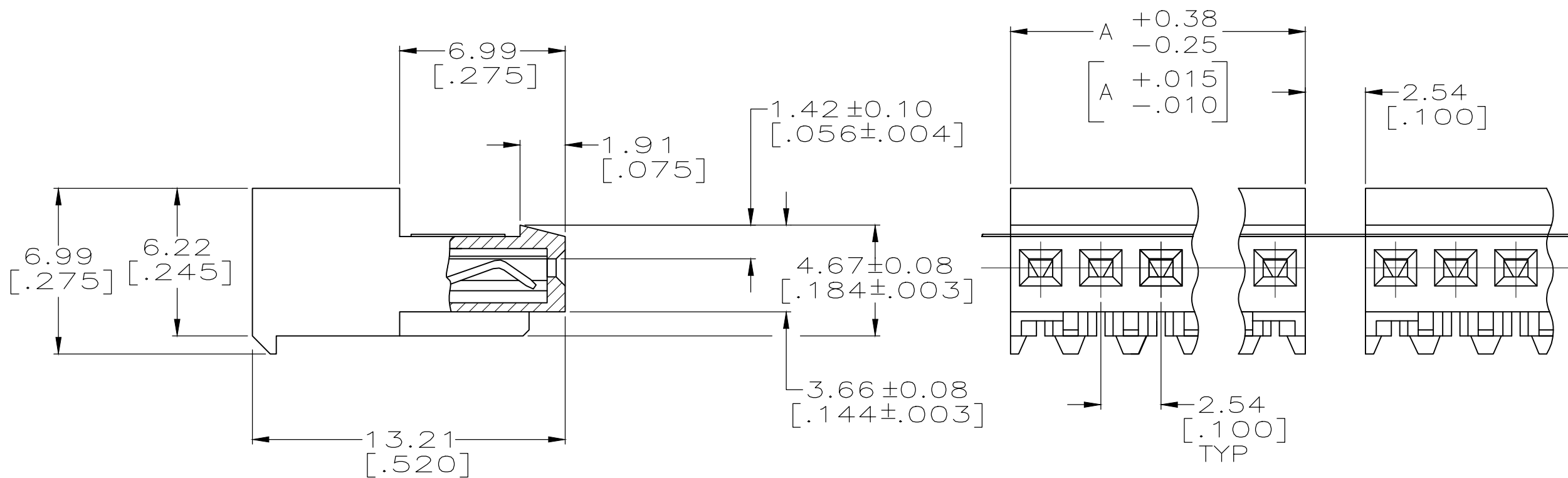

△ SUPERSEDED BY 5-640469-8	NO	71.12[2.800]	28	2-640469-8
△ SUPERSEDED BY 5-640469-7	NO	68.58[2.700]	27	2-640469-7
△ SUPERSEDED BY 5-640469-6	NO	66.04[2.600]	26	2-640469-6
△ SUPERSEDED BY 5-640469-5	NO	63.50[2.500]	25	2-640469-5
△ SUPERSEDED BY 5-640469-4	NO	60.96[2.400]	24	2-640469-4
△ SUPERSEDED BY 5-640469-3	NO	58.42[2.300]	23	2-640469-3
△ SUPERSEDED BY 5-640469-2	NO	55.88[2.200]	22	2-640469-2
△ SUPERSEDED BY 5-640469-1	NO	53.34[2.100]	21	2-640469-1
△ SUPERSEDED BY 5-640469-0	NO	50.80[2.000]	20	2-640469-0
△ SUPERSEDED BY 4-640469-9	NO	48.26[1.900]	19	1-640469-9
△ SUPERSEDED BY 4-640469-8	NO	45.72[1.800]	18	1-640469-8
△ SUPERSEDED BY 4-640469-7	NO	43.18[1.700]	17	1-640469-7
△ SUPERSEDED BY 4-640469-6	NO	40.64[1.600]	16	1-640469-6
△ SUPERSEDED BY 4-640469-5	NO	38.10[1.500]	15	1-640469-5
△ SUPERSEDED BY 4-640469-4	NO	35.56[1.400]	14	1-640469-4
△ SUPERSEDED BY 4-640469-3	NO	33.02[1.300]	13	1-640469-3
△ SUPERSEDED BY 4-640469-2	NO	30.48[1.200]	12	1-640469-2
△ SUPERSEDED BY 4-640469-1	NO	27.94[1.100]	11	1-640469-1
△ SUPERSEDED BY 4-640469-0	NO	25.40[1.000]	10	1-640469-0
△ SUPERSEDED BY 3-640469-9	NO	22.86[.900]	9	640469-9
△ SUPERSEDED BY 3-640469-8	NO	20.32[.800]	8	640469-8
△ SUPERSEDED BY 3-640469-7	NO	17.78[.700]	7	640469-7
△ SUPERSEDED BY 3-640469-6	NO	15.24[.600]	6	640469-6
△ SUPERSEDED BY 3-640469-5	NO	12.70[.500]	5	640469-5
△ SUPERSEDED BY 3-640469-4	NO	10.16[.400]	4	640469-4
△ SUPERSEDED BY 3-640469-3	NO	7.62[.300]	3	640469-3
△ SUPERSEDED BY 3-640469-2	NO	5.08[.200]	2	640469-2

LEADFREE	DIM A	NO. OF CIRCUITS	PART NO.

THIS DRAWING IS A CONTROLLED DOCUMENT.		DWN S. CARPENTER 22JUL2003	TE Connectivity Ltd.	
DIMENSIONS: INCHES		CHK D. BOSSI 22JUL2003		
TOLERANCES UNLESS OTHERWISE SPECIFIED:		APVD D. BOSSI 22JUL2003	NAME MTA-100 CONNECTOR ASSEMBLY, 24 AWG, STANDARD, TAPE MOUNTED	
0 PLC ± 1 PLC ± 2 PLC ± 3 PLC ± 0.13 [.005] 4 PLC ± ANGLES ± FINISH		PRODUCT SPEC 108-1050	SIZE A2	CAGE CODE 00779
MATERIAL		APPLICATION SPEC 114-1019	DRAWING NO C-640469	RESTRICTED TO -
CUSTOMER DRAWING		WEIGHT	SCALE 5:1	SHEET 1 OF 1
			REV AC	