

10 9 8 7 6 5 4 3 2 86160

ADAPTER P/N	SPRING LEVER COLOR	MATERIAL OF SLEEVE	SHELL COLOR
86160-0000	BLUE	PHOSPHOR BRONZE	BLUE
86161-0000		Zr	
*86989-0069		Zr	
86160-1000	BLACK	PHOSPHOR BRONZE	RED
86161-1000		Zr	
86160-2000		PHOSPHOR BRONZE	
86161-2000	Zr	BLACK	
86160-3000	BLUE	PHOSPHOR BRONZE	GREEN
86160-3100*		Zr	
86161-3000		Zr	
86161-3100*	BLACK	PHOSPHOR BRONZE	BEIGE
86160-5000		Zr	
86161-5000		Zr	

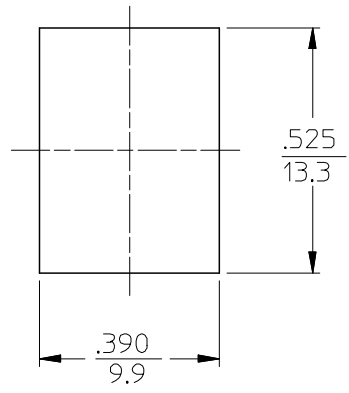
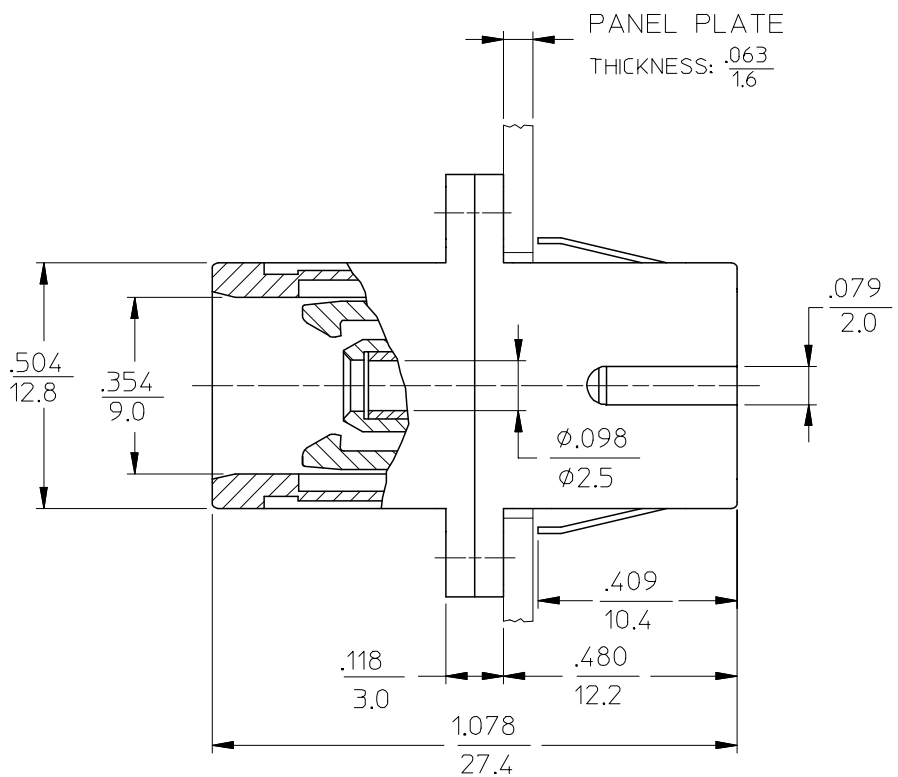
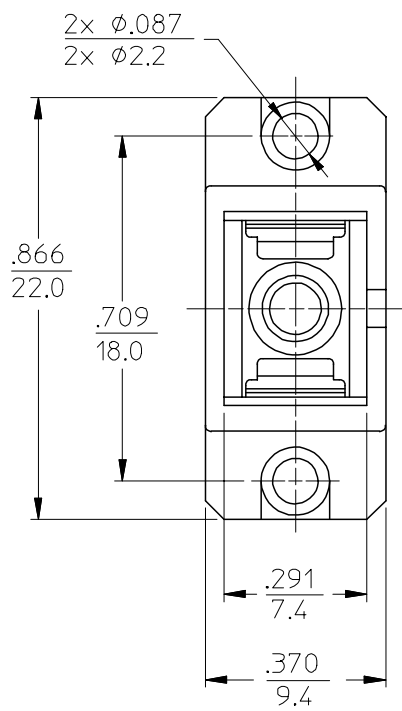

RECOMMENDED MOUNTING HOLE

NOTES:

- 1. DUST CAPS ARE NOT SHOWN BUT INCLUDED.
- *2. P/NS 86160-3100, 86161-3100, AND 86989-0069 ARE BULK PACKED IN QUANTITIES OF 100 pcs.

ENTER DESCRIPTION EC NO: MF2005-0443 DRWN: GUMIN 2005/02/07 CHKD: GUMIN 2005/02/07 APPR: GUMIN 2005/02/08	QUALITY SYMBOLS ▽ = 0 ▽ = 0	GENERAL TOLERANCES (UNLESS SPECIFIED)		SCALE 4:1	DESIGN UNITS INCH	THIRD ANGLE PROJECTION	REVISE ON CAD ONLY	
		4 PLACES ± --- ± --- 3 PLACES ± --- ± --- 2 PLACES ± --- ± --- 1 PLACE ± --- ± ---	DIMENSION STYLE IN/MM	TITLE SC TYPE ADAPTER				
		ANGULAR ±1/2°		DRAWN BY DATE	CHECKED BY DATE	MATERIAL NO. SEE TABLE	DOCUMENT NO. 8616X-X000CD	SHEET NO. 1 OF 1
		DRAFT WHERE APPLICABLE MUST REMAIN WITHIN DIMENSIONS		APPROVED BY DATE	THIS DRAWING CONTAINS INFORMATION THAT IS PROPRIETARY TO MOLEX INCORPORATED AND SHOULD NOT BE USED WITHOUT WRITTEN PERMISSION			

9 8 7 6 5 4 3 2 1