

HOA698X/699X

Transmissive Optoschmitt Sensor

FEATURES

- Direct TTL interface
- Buffer or inverting logic available
- Three device output options
- Four mounting configurations
- Choice of detector aperture
- 0.125 in.(3.18 mm) slot width
- 24.0 in.(610 mm) min. 26 AWG UL 1429 wire leads

DESCRIPTION

The HOA698X/699X series consists of an infrared emitting diode facing an Optoschmitt detector encased in a black thermoplastic housing. Detector switching takes place whenever an opaque object passes through the slot between emitter and detector. The photodetector consists of a photodiode, amplifier, voltage regulator, Schmitt trigger and various output configurations. The user can choose from available options: (1) detector aperture, (2) mounting tab configuration, (3) detector output configuration, and (4) housing material.

The HOA698X series utilizes an IR transmissive polysulfone housing which features smooth optical faces without external aperture openings; this feature is desirable when aperture blockage from airborne contaminants is a possibility. The HOA699X series employs an opaque polysulfone housing with aperture openings for use in applications in which maximum rejection of ambient light is important, and situations in which maximum position resolution is desired. The HOA698X/699X series employs plastic molded components. For additional component information see SEP8506 and SDP8XX4.

Housing material is polysulfone. Housings are soluble in chlorinated hydrocarbons and ketones. Recommended cleaning agents are methanol and isopropanol.

Device Polarity:

- Buffer - Output is LO when optical path is blocked.
- Inverter - Output is HI when optical path is blocked.

Wire color code and functions are:

- Red - IRED Anode
- White - Detector V_{cc}
- Black - IRED Cathode
- Blue - Detector Output
- Green - Detector Ground

To specify the complete product characteristics, see PART NUMBER GUIDE.

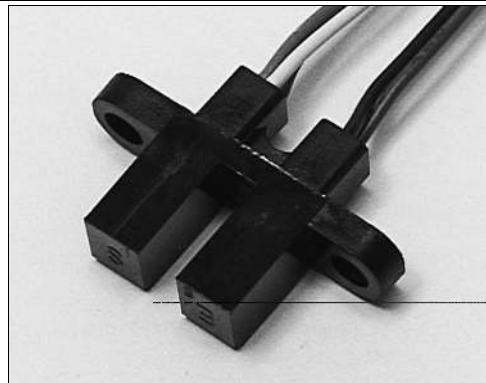

INFRA-4.TIF

OUTLINE DIMENSIONS in inches (mm)

Tolerance	3 plc decimals	±0.010(0.25)
	2 plc decimals	±0.020(0.51)

Package T

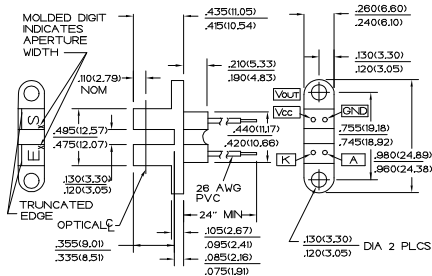

DIM_067a.cdr

Packages N/P/L

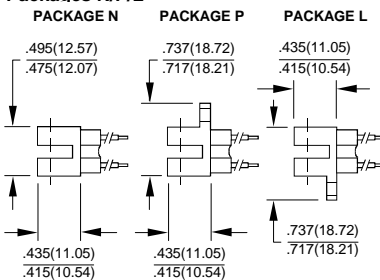

DIM_067.d4

HOA698X/699X

Transmissive Optoschmitt Sensor Totem-Pole Output

ELECTRICAL CHARACTERISTICS (-40°C to +70°C unless otherwise noted)

PARAMETER	SYMBOL	MIN	TYP	MAX	UNITS	TEST CONDITIONS
IR EMITTER						
Forward Voltage	V_F			1.6	V	$I_F=20\text{ mA}$, $T_A=25^\circ\text{C}$
Reverse Leakage Current	I_R			10	μA	$V_R=3\text{ V}$, $T_A=25^\circ\text{C}$
DETECTOR						
Operating Supply Voltage	V_{CC}	4.5		7.0	V	$T_A=25^\circ\text{C}$
Low Level Supply Current	I_{CCL}			15	mA	$V_{CC}=5.25\text{ V}$
High Level Supply Current	I_{CCH}			15	mA	$V_{CC}=5.25\text{ V}$
Low Level Output Voltage	V_{OL}				V	$V_{CC}=4.75\text{ V}$, $I_{OL}=12.8\text{ mA}$
HOA6980/6990				0.4		$I_F=0\text{ mA}$
HOA6982/6992				0.4		$I_F=15\text{ mA}$
High Level Output Voltage	V_{OH}				V	$V_{CC}=4.75\text{ V}$, $I_{OH}=800\text{ }\mu\text{A}$,
HOA6980/6990		2.4				$I_F=15\text{ mA}$
HOA6982/6992		2.4				$I_F=0\text{ mA}$
Short Circuit Output Current	I_{OS}				mA	$V_{CC}=5.25\text{ V}$, Output=GND
HOA6980/6990		-20		-100		$I_F=15\text{ mA}$
HOA6982/6992		-20		-100		$I_F=0\text{ mA}$
Hysteresis ⁽²⁾	HYST		50		%	
Propagation Delay, Low-High, High-Low	t_{PLH} , t_{PHL}		5		μs	$V_{CC}=5\text{ V}$, $I_F=0$ or 15 mA $R_L=8\text{ TTL Loads}$
Output Rise Time, Output Fall Time	t_r , t_f		70		ns	$V_{CC}=5\text{ V}$, $I_F=0$ or 15 mA $R_L=8\text{ TTL Loads}$
COUPLED CHARACTERISTICS						
IREDD Trigger Current	I_{FT}			15	mA	$V_{CC}=5\text{ V}$

Notes

- It is recommended that a bypass capacitor, 0.1 μF typical, be added between V_{CC} and GND near the device in order to stabilize power supply line.
- Hysteresis is defined as the difference between the operating and release threshold intensities, expressed as a percentage of the operate threshold intensity.

ABSOLUTE MAXIMUM RATINGS

(25°C Free-Air Temperature unless otherwise noted)

Operating Temperature Range	-40°C to 70°C
Storage Temperature Range	-40°C to 85°C
Soldering Temperature (5 sec)	240°C

IR EMITTER

Power Dissipation	100 mW ⁽¹⁾
Reverse Voltage	3 V
Continuous Forward Current	50 mA

DETECTOR

Supply Voltage:	
Totem-Pole Output	7 V ⁽²⁾
All Others	12 V ⁽²⁾
Duration of Output	
Short to V_{CC} or Ground	1.0 sec.

Notes

- Derate linearly at 0.78 mW/°C above 25°C.
- Derate linearly from 25°C to 5.5 V at 70°C.

Honeywell reserves the right to make changes in order to improve design and supply the best products possible.

Honeywell

HOA698X/699X

Transmissive Optoschmitt Sensor Open-Collector Output

ELECTRICAL CHARACTERISTICS (-40°C to +70°C unless otherwise noted)

PARAMETER	SYMBOL	MIN	TYP	MAX	UNITS	TEST CONDITIONS
IR EMITTER						
Forward Voltage	V_F		1.6		V	$I_F=20\text{ mA}$, $T_A=25^\circ\text{C}$
Reverse Leakage Current	I_R		10		μA	$V_R=3\text{ V}$, $T_A=25^\circ\text{C}$
DETECTOR						
Operating Supply Voltage	V_{CC}	4.5	12		V	$T_A=25^\circ\text{C}$
Low Level Supply Current	I_{CCL}		15		mA	$V_{CC}=5.25\text{ V}$
High Level Supply Current	I_{CCH}		15		mA	$V_{CC}=5.25\text{ V}$
Low Level Output Voltage	V_{OL}				V	$V_{CC}=4.75\text{ V}$, $I_{OL}=12.8\text{ mA}$
HOA6981/6991			0.4			$I_F=0\text{ mA}$
HOA6983/6993			0.4			$I_F=15\text{ mA}$
High Level Output Current	I_{OH}				μA	$V_{CC}=4.75\text{ V}$, $V_{OH}=30\text{ V}$
HOA6981/6991			100			$I_F=15\text{ mA}$
HOA6983/6993			100			$I_F=0\text{ mA}$
Hysteresis ⁽²⁾	HYST		50		%	
Propagation Delay, Low-High, High-Low	t_{PLH} , t_{PHL}		5		μs	$V_{CC}=5\text{ V}$, $I_F=0$ or 15 mA $R_L=390\ \Omega$
Output Rise Time, Output Fall Time	t_r , t_f		70		ns	$V_{CC}=5\text{ V}$, $I_F=0$ or 15 mA $R_L=390\ \Omega$
COUPLED CHARACTERISTICS						
IRED Trigger Current	I_{FT}		15		mA	$V_{CC}=5\text{ V}$

Notes

- It is recommended that a bypass capacitor, 0.1 μF typical, be added between V_{CC} and GND near the device in order to stabilize power supply line.
- Hysteresis is defined as the difference between the operating and release threshold intensities, expressed as a percentage of the operate threshold intensity.

ABSOLUTE MAXIMUM RATINGS

(25°C Free-Air Temperature unless otherwise noted)

Operating Temperature Range	-40°C to 70°C
Storage Temperature Range	-40°C to 70°C
Soldering Temperature (5 sec)	240°C

IR EMITTER

Power Dissipation	100 mW ⁽¹⁾
Reverse Voltage	3 V
Continuous Forward Current	50 mA

DETECTOR

Supply Voltage:	
Totem-Pole Output	7 V ⁽²⁾
All Others	12 V ⁽²⁾
Duration of Output	
Short to V_{CC} or Ground	1.0 sec
Applied Output Voltage	35 V

Notes

- Derate linearly at 0.78 mW/°C above 25°C.
- Derate linearly from 25°C to 5.5 V at 70°C.

HOA698X/699X

Transmissive Optoschmitt Sensor
10 kOhm Pull-Up Output

ELECTRICAL CHARACTERISTICS (-40°C to +70°C unless otherwise noted)

PARAMETER	SYMBOL	MIN	TYP	MAX	UNITS	TEST CONDITIONS
IR EMITTER						
Forward Voltage	V_F		1.6		V	$I_F=20\text{ mA}$, $T_A=25^\circ\text{C}$
Reverse Leakage Current	I_R		10		μA	$V_R=3\text{ V}$, $T_A=25^\circ\text{C}$
DETECTOR						
Operating Supply Voltage	V_{CC}	4.5	12		V	$T_A=25^\circ\text{C}$
Low Level Supply Current	I_{CCL}		15		mA	$V_{CC}=5.25\text{ V}$
High Level Supply Current	I_{CCH}		15		mA	$V_{CC}=5.25\text{ V}$
Low Level Output Voltage HOA6984/6994	V_{OL}		0.4 0.4		V	$V_{CC}=4.75\text{ V}$, $I_{OL}=12.8\text{ mA}$ $I_F=0\text{ mA}$ $I_F=15\text{ mA}$
High Level Output Voltage HOA6984/6994 HOA6985/6995	V_{OH}	2.4 2.4			V	$V_{CC}=4.75\text{ V}$, $I_{OH}=100\text{ }\mu\text{A}$, $I_F=15\text{ mA}$ $I_F=0\text{ mA}$
Hysteresis ⁽²⁾	HYST		50		%	
Propagation Delay, Low-High, High-Low	t_{PLH} , t_{PHL}		5		μs	$V_{CC}=5\text{ V}$, $I_F=0$ or 15 mA $R_L=390\text{ }\Omega$
Output Rise Time, Output Fall Time	t_r , t_f		70		ns	$V_{CC}=5\text{ V}$, $I_F=0$ or 15 mA $R_L=390\text{ }\Omega$
COUPLED CHARACTERISTICS						
IRET Trigger Current	I_{FT}		15		mA	$V_{CC}=5\text{ V}$

Notes

- It is recommended that a bypass capacitor, 0.1 μF typical, be added between V_{CC} and GND near the device in order to stabilize power supply line.
- Hysteresis is defined as the difference between the operating and release threshold intensities, expressed as a percentage of the operate threshold intensity.

ABSOLUTE MAXIMUM RATINGS

(25°C Free-Air Temperature unless otherwise noted)

Operating Temperature Range	-40°C to 70°C
Storage Temperature Range	-40°C to 85°C
Soldering Temperature (5 sec)	240°C

IR EMITTER

Power Dissipation	100 mW ⁽¹⁾
Reverse Voltage	3 V
Continuous Forward Current	50 mA

DETECTOR

Supply Voltage:	
Totem-Pole Output	7 V ⁽²⁾
All Others	12 V ⁽²⁾
Duration of Output	
Short to V_{CC} or Ground	1.0 sec

Notes

- Derate linearly at 0.78 mW/°C above 25°C.
- Derate linearly from 25°C to 5.5 V at 70°C.

Honeywell reserves the right to make changes in order to improve design and supply the best products possible.

Honeywell

HOA698X/699X

Transmissive Optoschmitt Sensor

SCHEMATIC FOR HOA698X/699X

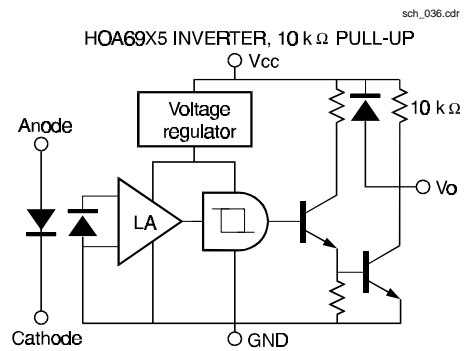
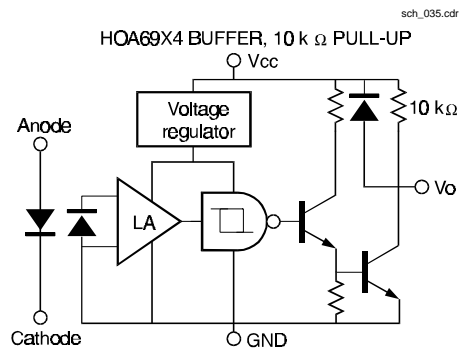
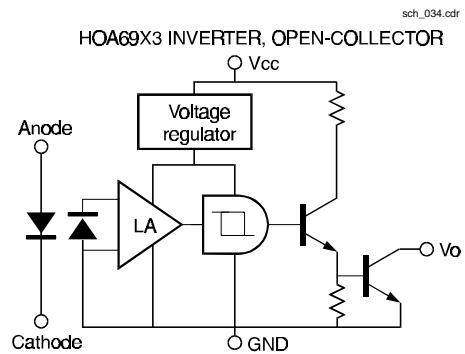
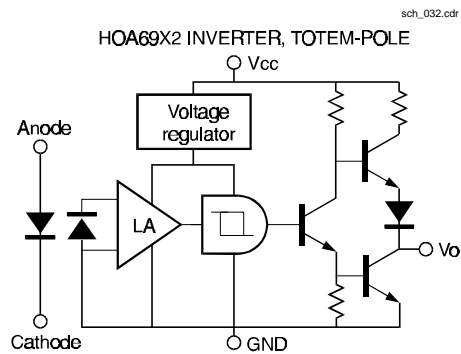
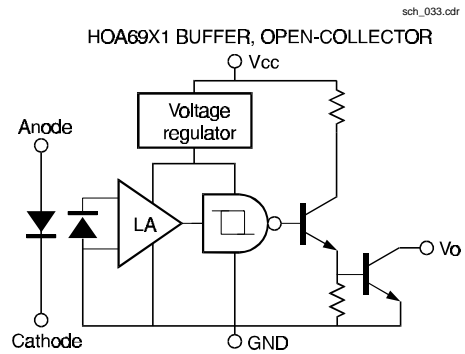
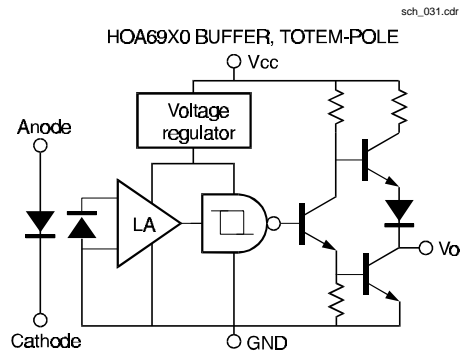

HOA698X/699X

Transmissive Optoschmitt Sensor

SWITCHING WAVEFORM FOR BUFFERS

cir_013.cdr

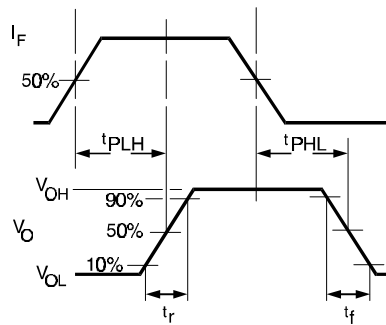
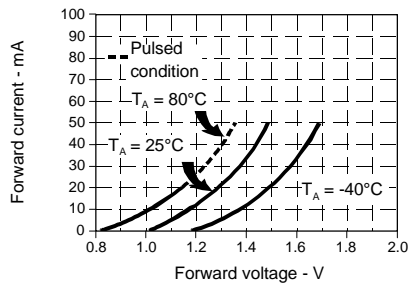

Fig. 1 IRED Forward Bias Characteristics

gra_073.ds4



SWITCHING WAVEFORM FOR INVERTERS

cir_011.cdr

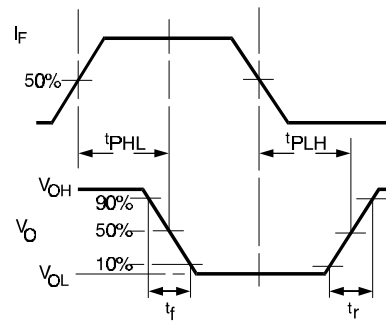
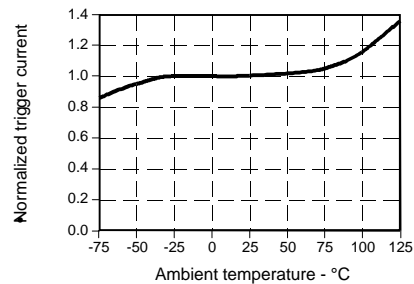

Fig. 2 IRED Trigger Current vs Temperature

gra_098.ds4



All Performance Curves Show Typical Values

PART NUMBER GUIDE

HOA69XX-XXX

Housing Material

- 8 = Polysulfone, IR transmissive
- 9 = Polysulfone, opaque

Output Configuration

- 0 = Totem-pole, buffer
- 1 = Open-collector, buffer
- 2 = Totem-pole, inverter
- 3 = Open-collector, inverter
- 4 = 10 kΩ pull-up, buffer
- 5 = 10 kΩ pull-up, inverter

Aperture Width In Front Of Detector

- 1 = 0.010 in. (0.25 mm)
- 5 = 0.050 in. (1.27 mm)
- Aperture length is 0.060 in. (1.52 mm)

Aperture Width In Front Of IRED

- 5 = 0.050 in. (1.27 mm)
- Aperture length is 0.060 in. (1.52 mm)

Mounting Configuration

- L = Single mounting tab, emitter side
- N = No mounting tabs
- P = Single mounting tab, detector side
- T = Two mounting tabs

Honeywell reserves the right to make changes in order to improve design and supply the best products possible.

Honeywell