

**SPECIFICATION  
FOR  
LCD Module**

**Customer P/N:**

**Santek P/N: ST0280A3WY-RSLW-F**

**DOC. Revision: RS01**

**Customer Approval:**

--

	<b>SIGNATURE</b>	<b>DATE</b>
<b>PREPARED BY</b>	Zhiyi Liao	2017-08-17
<b>CHECKED BY</b>	Sam & Tom	2017.08.18
<b>APPROVED BY</b>	Natty Lee	2017-Aug-21

Document Revision History

Version	Revise Date	Description	Changed by
RS01	2017-08-17	Initial release	Zhiyi Liao

Santek - CONFIDENTIAL

---

Table of Contents

1. GENERAL SPECIFICATION..... 4

2. BLOCK DIAGRAM..... 5

3. MECHANICAL DRAWING..... 6

4. INTERFACE ASSIGNMENT..... 7

5. ELECTRICAL SPECIFICATION..... 8

6. TOUCH PANEL SPECIFICATION..... 14

7. OPTICAL CHARACTERISTICS..... 17

8. RELIABILITY TESTSP..... 21

9. RECAUTIONS..... 22

10. LIMITED WARRANTY..... 22

Santek - CONFIDENTIAL

## 1. GENERAL SPECIFICATION

### 1.1 Description

The ST0280A3WY-RSLW-F is a color active matrix Thin Film Transistor (TFT) Liquid Crystal Display (LCD) that uses amorphous silicon(a-Si) TFT as a switching device. This model is composed of a single 2.8 inches transmissive type main TFT-LCD panel. The resolution of the panel is 240 x 320 pixels and can display up to 262K color.

### 1.2 Feature

- TM type for main TFT-LCD panel
- Structure COG+FPC+BL+TP
- Full, Normal (Still), Partial, Sleep, Standby mode are available

### 1.3 Application

- Display terminals for cellular phone or equivalent.

### 1.4 General Specification

No.	Item	Specification	Unit	Remark
1	LCD Size	2.8	inch	-
2	Panel Type	a-Si TFT active matrix	-	-
3	Resolution	240 x (RGB) x 320	pixel	-
4	Display Mode	Normally white, Transmissive	-	-
5	Display Number of Colors	262K	-	-
6	Viewing Direction	6 o'clock(Gray Scale)	-	Note
7	Contrast Ratio	500(TYP)	-	-
8	Luminance	210(TYP)	cd/m <sup>2</sup>	-
9	Module Size	50.00(W) x 69.20(L) x 3.65(T)	mm	Note
10	Active Area	43.20(W) x 57.60(L)	mm	Note
11	Pixel Pitch	0.180(W) x 0.180(L)	mm	-
12	Weight	-	g	-
13	Driver IC	ST7789V	-	-
14	Light Source	4 LEDs White	-	-
15	Interface	CPU 8/16bit	-	-
16	Operating Temperature	-20~70	°C	-
17	Storage Temperature	-30~80	°C	-

Note: Please refer to the mechanical drawing.

**2. BLOCK DIAGRAM**

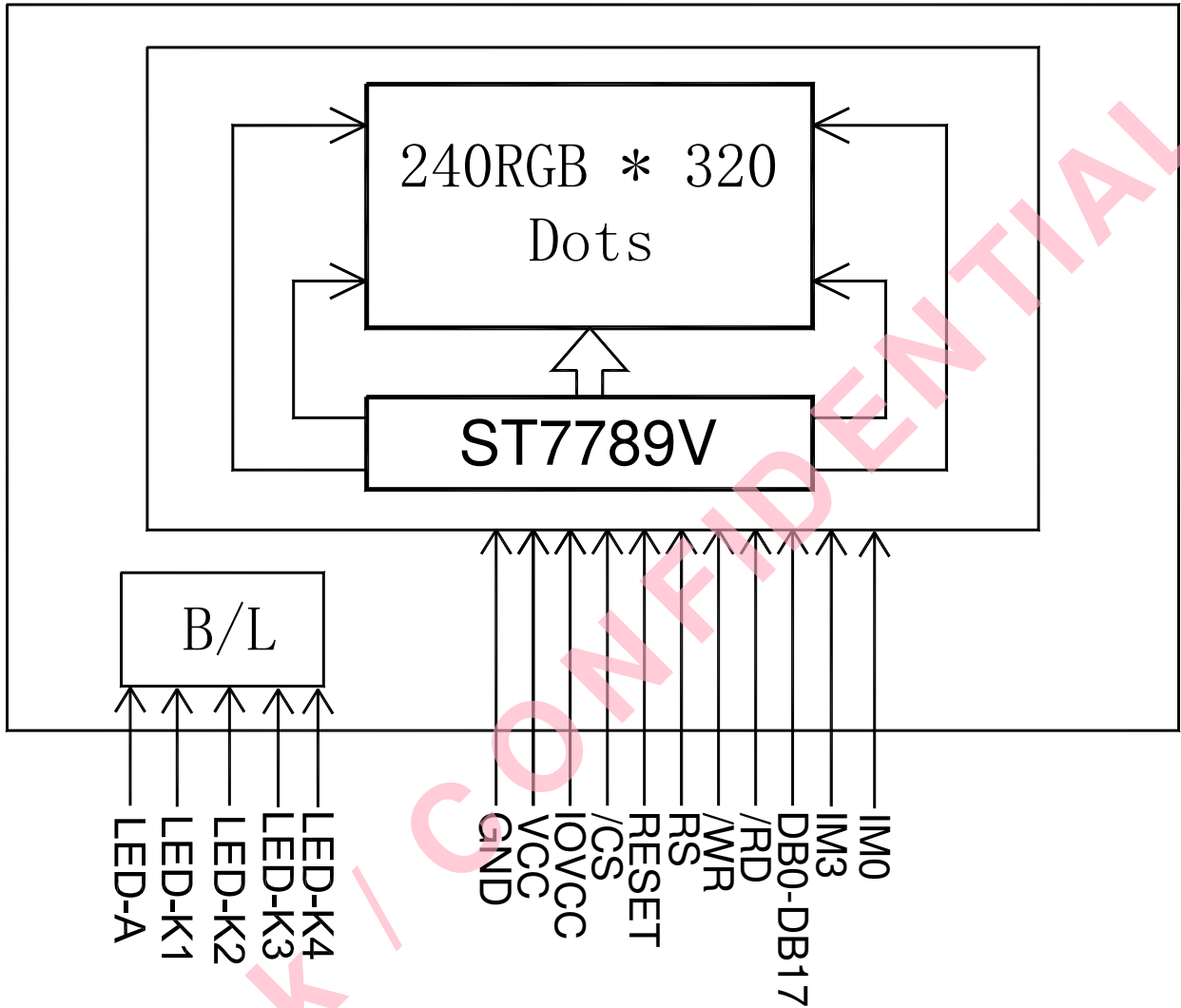



4. INTERFACE ASSIGNMENT

PIN NO.	SYMBOL	FUNCTION DESCRIPTIONS
1	GND	Ground.
2	/CS	A chip selection signal. When CS is low, the chip can be accessed.
3	RS	Display data/command selection pin in MCU interface. RS='1': display data or parameter. RS='0': command data.
4	/WR	Serves as a write signal and writes data at the rising edge.
5	/RD	Serves as a read signal and read data at the rising edge.
6~13	DB10-DB17	Data bus.
14~23	DB0-DB9	Data bus.
24	/RESET	Reset pin.
25	IM0	MCU parallel interface type selection. IM3='1' and IM0='0': i80-system 16-bit interface. DB[17:10], DB[8:1] is used;
26	IM3	IM3='1' and IM0='1': i80-system 8-bit interface. DB[17:10] is used;
27	GND	Ground.
28	XL	X-
29	YT	Y+
30	XR	X+
31	YB	Y-
32	GND	Ground.
33	VCC	Power supply to the analog circuit.
34	IOVCC	Power supply to the interface pins
35	LED-K1	Power supply for backlight (cathode).
36	LED-K2	Power supply for backlight (cathode).
37	LED-K3	Power supply for backlight (cathode).
38	LED-K4	Power supply for backlight (cathode).
39	LED-A	Power supply for backlight (anode).

**5. ELECTRICAL SPECIFICATION**  
**5.1. APPLICATION CIRCUIT**

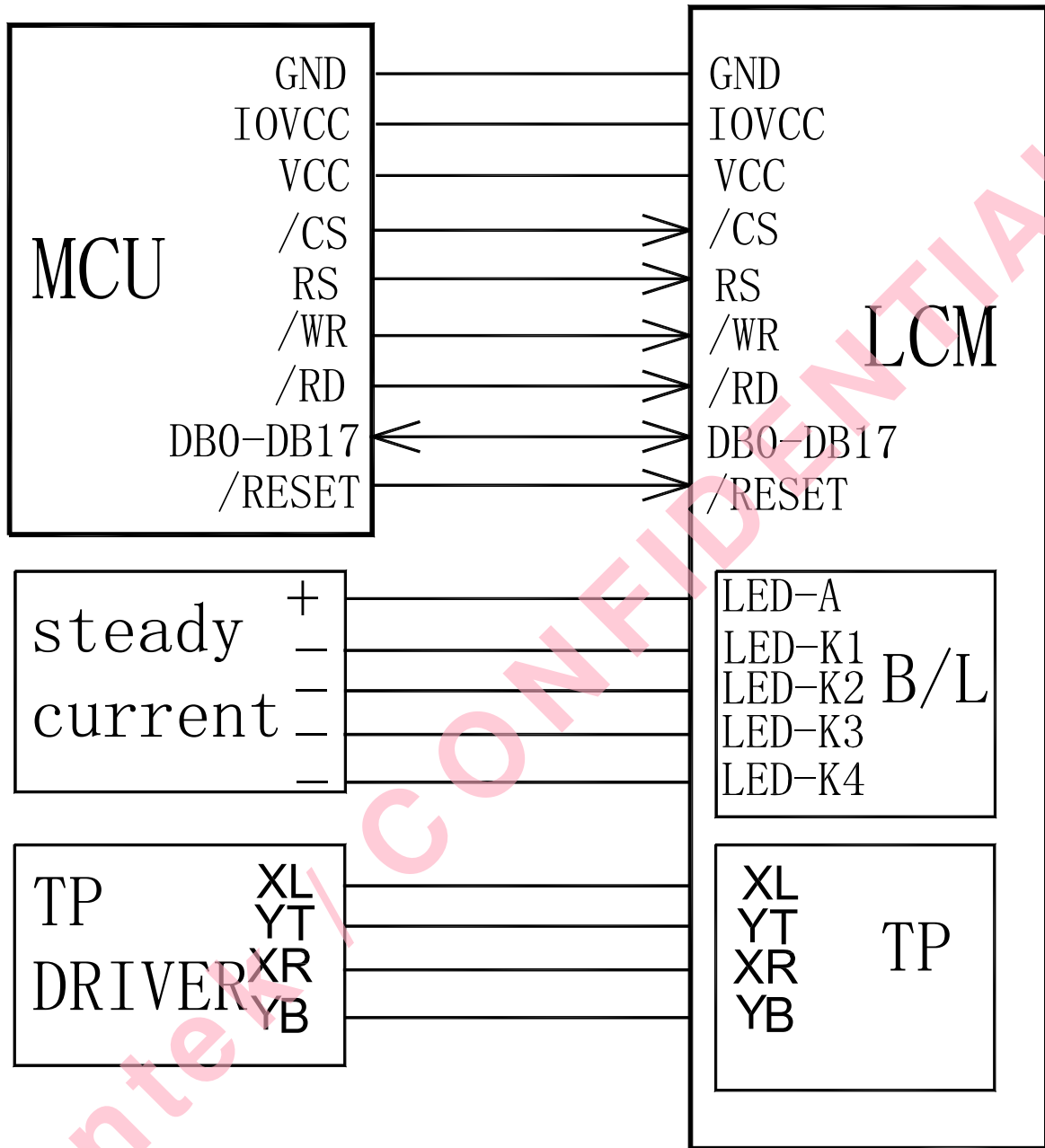



## 5.2. ABSOLUTE MAXIMUM RATINGS

ITEM	SYMBOL	CONDITION	STANDARD VALUE			UNIT
			MIN	TYP	MAX	
Power Supply for Analog	VCC	Ta=25 °C	-0.3	-	4.6	V
Power Supply for Digital IO	IOVCC	Ta=25 °C	-0.3	-	4.6	V

Note: Permanent damage to the device may occur if maximum values are exceeded or reverse voltage is applied.

## 5.3. TYPICAL OPERATION CONDITION

### 5.3.1 DC Characteristics

ITEM	SYMBOL	CONDITION	STANDARD VALUE			UNIT
			MIN	TYP	MAX	
Power Supply for Analog	VCC	Ta=25 °C	2.4	2.8	3.3	V
Power Supply for Digital IO	IOVCC	Ta=25 °C	1.65	1.8	3.3	V
Input Signal "H" Level	V <sub>IH</sub>	-	0.7×IOVCC	-	IOVCC	V
Input Signal "L" Level	V <sub>IL</sub>	-	-0.3	-	0.3×IOVCC	V
Output Signal "H" Level	V <sub>OH</sub>	I <sub>OH</sub> =-0.1mA	0.8×IOVCC	-	-	V
Output Signal "L" Level	V <sub>OL</sub>	I <sub>OL</sub> =0.1mA	-	-	0.2×IOVCC	V
Frame Frequency	f <sub>FRAME</sub>	-	60	70	85	Hz

Note: To prevent IC latch up or DC operation in LCD panel, the power on/off sequence should follow the driver IC specification.

5.3.2 Current Consumption

Item	Symbol	Values		Unit	Remark
		Min.	Max.		
Normal(Still) Mode	I <sub>CC1</sub>	-	10	mA	Note1
Sleep Mode	I <sub>CC2</sub>	-	100	uA	Note2

Note1: Test Condition

IOVCC=VCC=2.8V;

Display Pattern: All Pixel Black

Frame Rate=77Hz at Line Inversion

Operating Temperature: 25°C

Max. current check pattern:



Black

Note2: In the standby mode, all the internal display operations are suspended including the internal R-C oscillator.

**5.4. BACKLIGHT SPECIFICATION**

**5.4.1 BACKLIGHT CIRCUIT**

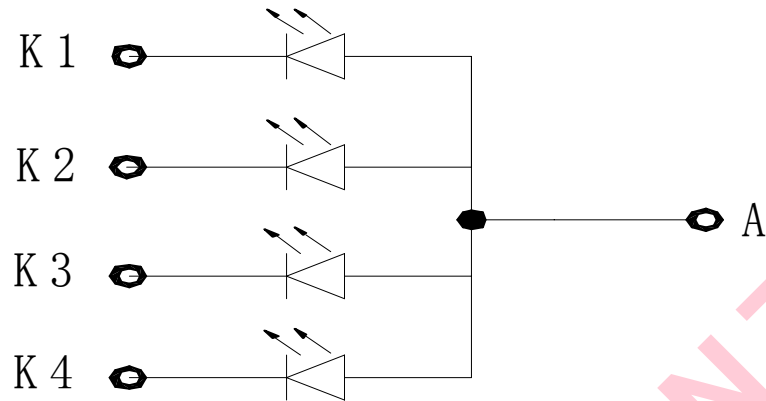

**5.4.2 ELECTRICAL CHARACTERISTICS**

(T=25°C)

PARAMETER	SYMBOL	CONDITION	STANDARD VALUE			UNIT
			MIN	TYP	MAX	
FORWARD VOLTAGE (Single Chip)	VF	IF=15mA	2.9	3.2	3.5	V

5.5. INTERFACE TIMING CHARACTERISTICS

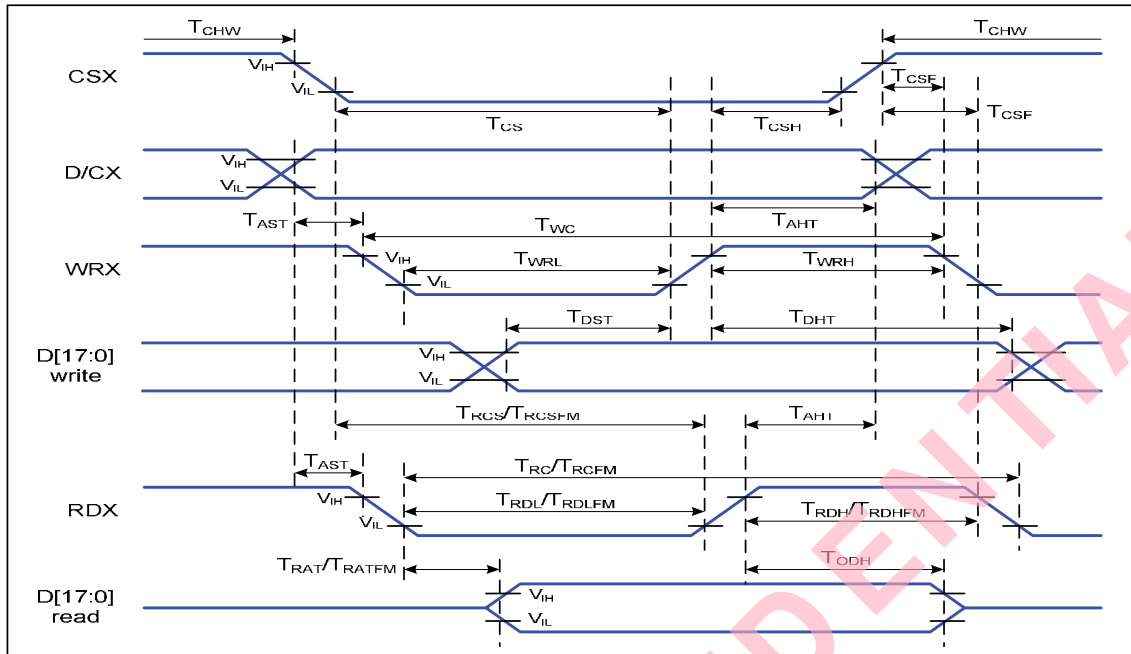

Figure 1 Parallel Interface Timing Characteristics (8080-Series MCU Interface)

VDDI=1.65 to 3.3V, VDD=2.4 to 3.3V, AGND=DGND=0V, Ta= -30 to 70 °C

Signal	Symbol	Parameter	Min	Max	Unit	Description
D/CX	T <sub>AST</sub>	Address setup time	0		ns	-
	T <sub>AHT</sub>	Address hold time (Write/Read)	10		ns	-
CSX	T <sub>CHW</sub>	Chip select "H" pulse width	0		ns	-
	T <sub>CS</sub>	Chip select setup time (Write)	15		ns	-
	T <sub>RCS</sub>	Chip select setup time (Read ID)	45		ns	-
	T <sub>RCSFM</sub>	Chip select setup time (Read FM)	355		ns	-
	T <sub>CSF</sub>	Chip select wait time (Write/Read)	10		ns	-
	T <sub>CSH</sub>	Chip select hold time	10		ns	-
WRX	T <sub>WC</sub>	Write cycle	66		ns	-
	T <sub>WRH</sub>	Control pulse "H" duration	15		ns	-
	T <sub>WRL</sub>	Control pulse "L" duration	15		ns	-
RDX (ID)	T <sub>RC</sub>	Read cycle (ID)	160		ns	When read ID data
	T <sub>RDH</sub>	Control pulse "H" duration (ID)	90		ns	
	T <sub>RDL</sub>	Control pulse "L" duration (ID)	45		ns	
RDX (FM)	T <sub>RCFM</sub>	Read cycle (FM)	450		ns	When read from frame memory
	T <sub>RDHFM</sub>	Control pulse "H" duration (FM)	90		ns	
	T <sub>RDLFM</sub>	Control pulse "L" duration (FM)	355		ns	
D[17:0]	T <sub>DST</sub>	Data setup time	10		ns	For CL=30pF

5.6. RESET TIMING CHARACTERISTICS

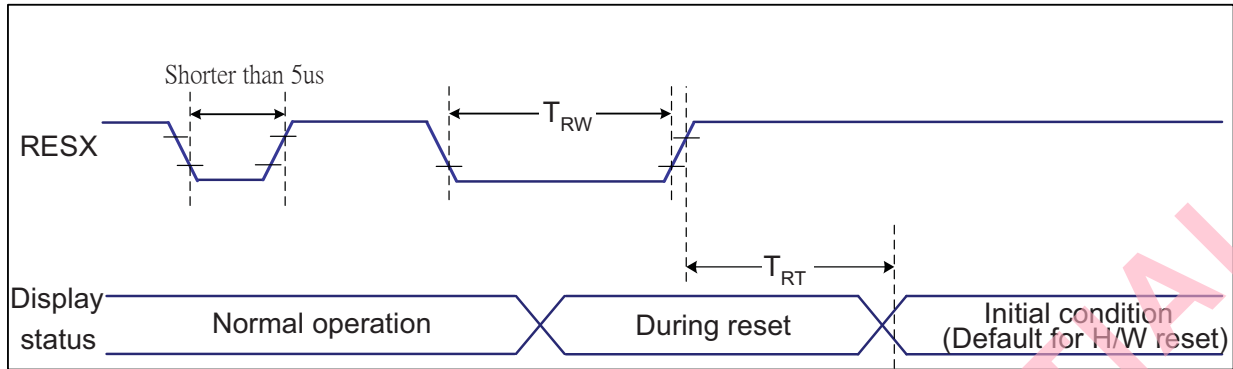

Figure 2 RESET TIMING

VDDI=1.65 to 3.3V, VDD=2.4 to 3.3V, AGND=DGND=0V, Ta=-30 ~ 70 °C

Related Pins	Symbol	Parameter	MIN	MAX	Unit
RESX	TRW	Reset pulse duration	10	-	us
	TRT	Reset cancel	-	5 (Note 1, 5)	ms
				120 (Note 1, 6, 7)	ms

Notes:

- The reset cancel includes also required time for loading ID bytes, VCOM setting and other settings from NVM (or similar device) to registers. This loading is done every time when there is HW reset cancel time (tRT) within 5 ms after a rising edge of RESX.
- Spike due to an electrostatic discharge on RESX line does not cause irregular system reset according to the table below:

RESX Pulse	Action
Shorter than 5us	Reset Rejected
Longer than 9us	Reset
Between 5us and 9us	Reset starts

3. During the Resetting period, the display will be blanked (The display is entering blanking sequence, which maximum time is 120 ms, when Reset Starts in Sleep Out –mode. The display remains the blank state in Sleep In –mode.) and then return to Default condition for Hardware Reset.

4. Spike Rejection also applies during a valid reset pulse as shown below:

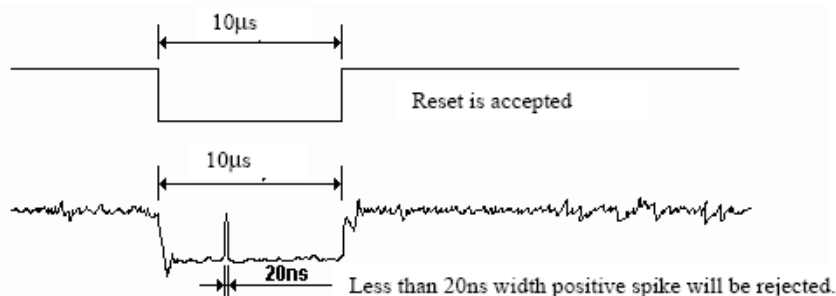

**6. TOUCH PANEL SPECIFICATION**

**6.1. ELECTRICAL CHARACTERISTICS**

Item	Value			Unit	Remark
	Min.	Typ.	Max.		
Linearity	-1.5	-	+1.5	%	After environment and life test
Terminal Resistance	100	-	900	Ω	X(Film side)
	200	-	900	Ω	Y(Glass side)
Insulation resistance	20	-	-	MΩ	DC 25V 1min
Operating Voltage	-	5	7	V	DC

**6.2. OPTICAL CHARACTERISTICS**

Item	Value			Unit	Remark
	Min.	Typ.	Max.		
Response Time	-	-	10	ms	100kΩ pull-up
Light Transparency	79	-	-	%	-

**6.3. MECHANICAL CHARACTERISTICS**

Item	Value			Unit	Remark
	Min.	Typ.	Max.		
Active Force	70	-	120	gf	Note1
Surface Hardness	3	-	-	H	-
Pen Sliding Durability	50,000	-	-	time	Note 2
Hitting Durability	1,000,000	-	-	time	Note 3

Note 1: Do not operate it with a stylus other than a polyacetal pen (tip R0.8mm or less) or a finger, especially those with hard or sharp tips such as a ball point pen or a mechanical pencil.

Note 2: Test Condition:End shape: R0.8mm and R8.0mm

Resistance between X and Y axis must be equal or lower than 2KΩ, the test voltage =DC5V.

Note 3: Measurement For Linearity. (After environment and life test)

-Load: 70g with End shape R0.8 mm Polyacetal resin.

-Measuring area: 1.0mm inside the edge of touch panel active area, pitch 5mm. (Fig. 1)

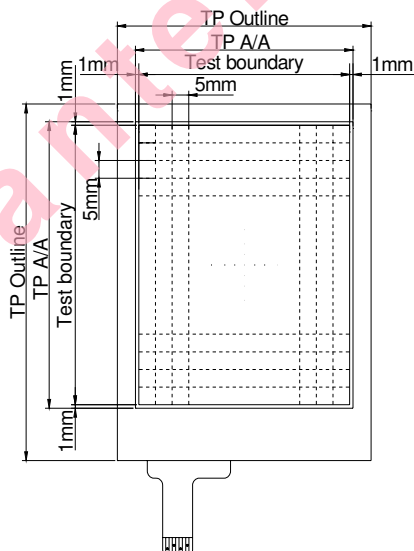

Fig. 1 Measuring area for Linearity

Note 4: Measurement for surface area.

- Scratch 100,000 times of straight line on the screen with a stylus which is changed every 20,000 times. One time is defined in one direction, strike one time, and then in the reverse direction strike one time that defined 2nd time.
- Force: 150gf.
- Speed: 150mm/sec.
- Writing Length: 25mm.
- Stylus: R0.8 polyacetal tip.
- Measuring area: 2.0mm inside the edge of touch panel active area, any line. (Fig. 2)
- Result: the SPEC of Electrical Characteristics pass.

Note 5: Hit 1,000,000 times on the screen with a R0.8mm Polyacetal resin By stylus tapping at same points.

- Force: 250gf.
- Speed: 5times/sec.
- Measuring area: 2.0mm inside the edge of touch panel active area, any point. (Fig. 2)
- Result: The SPEC of Electrical Characteristics pass.

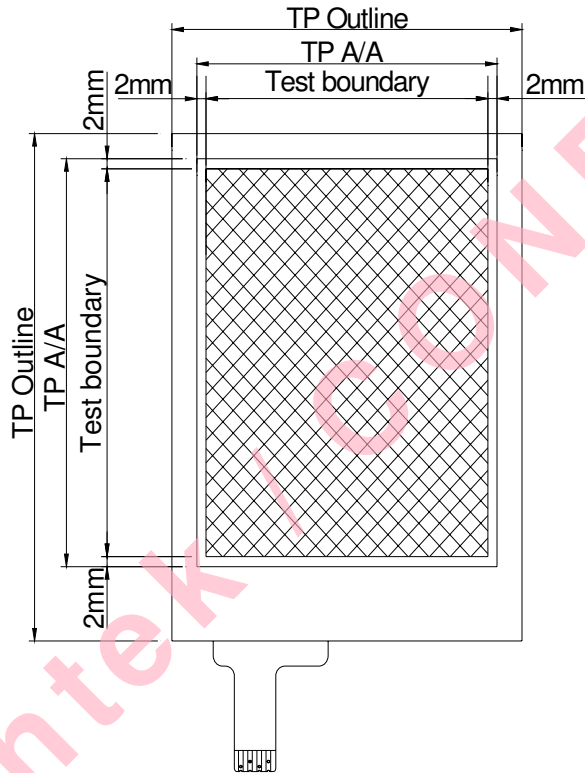
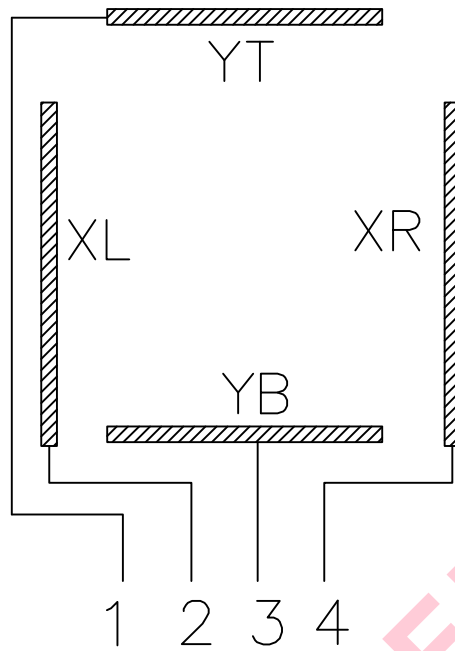

Fig. 2 Measuring area for Pen Sliding & Hitting Durability

6.4. TOUCH PANEL CIRCUIT BLOCK



Santek - CONFIDENTIAL



7. OPTICAL CHARACTERISTICS

( $T_a=+25^{\circ}\text{C}$ ,  $V_{CC}=I_{OVCC}=+2.8\text{V}$ ,  $I_{BL}=80\text{mA}$ )

Item	Symbol	Condition	Values			Unit	Remark	
			Min.	Typ.	Max.			
Viewing Angle Range	Left	$\theta_L$	$CR \geq 10$	-	45	-	degree	Note 1,2
	Right	$\theta_R$		-	45	-		
	Top	$\Phi_T$		-	50	-		
	Bottom	$\Phi_B$		-	20	-		
Response Time	$T_{on} + T_{off}$	Normal $\theta = \Phi = 0^{\circ}$	-	16	-	ms	Note 2,3	
Contrast Ratio	CR	Normal $\theta = \Phi = 0^{\circ}$	-	500	-	-	Note 2,4	
Luminance	L	Normal $\theta = \Phi = 0^{\circ}$	190	210	-	cd/m <sup>2</sup>	Note 2,5	
Color Chromaticity (CIE1931)	White	$W_x$	Normal $\theta = \Phi = 0^{\circ}$	0.2460	0.2960	0.3460	-	Note 2,6
		$W_y$		0.2663	0.3163	0.3663		
	Red	$R_x$		0.5797	0.6297	0.6797		
		$R_y$		0.3016	0.3516	0.4216		
	Green	$G_x$		0.2939	0.3439	0.4039		
		$G_y$		0.5523	0.6023	0.6523		
	Blue	$B_x$		0.0947	0.1447	0.1947		
		$B_y$		0.0241	0.0741	0.1241		
Color Gamut	NTSC	CIE1931	-	55.3	-	%	-	
Luminance Uniformity	$U_L$	Normal $\theta = \Phi = 0^{\circ}$	75	80	-	%	Note 2,7	

Note 1: Definition of viewing angle range

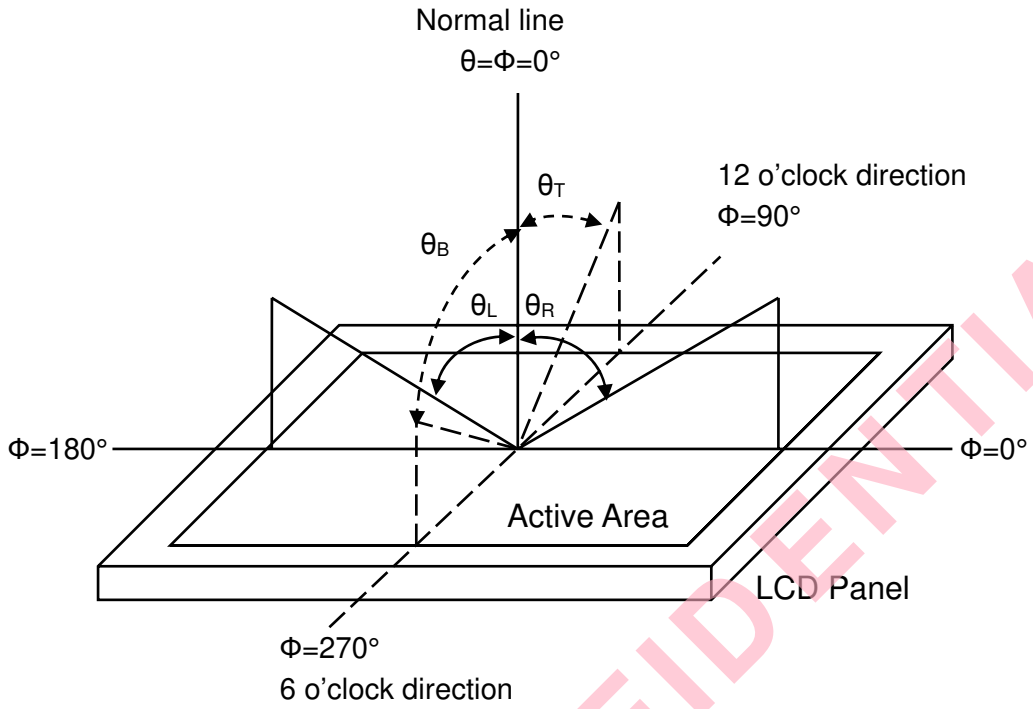

Fig. 1 Definition of viewing angle

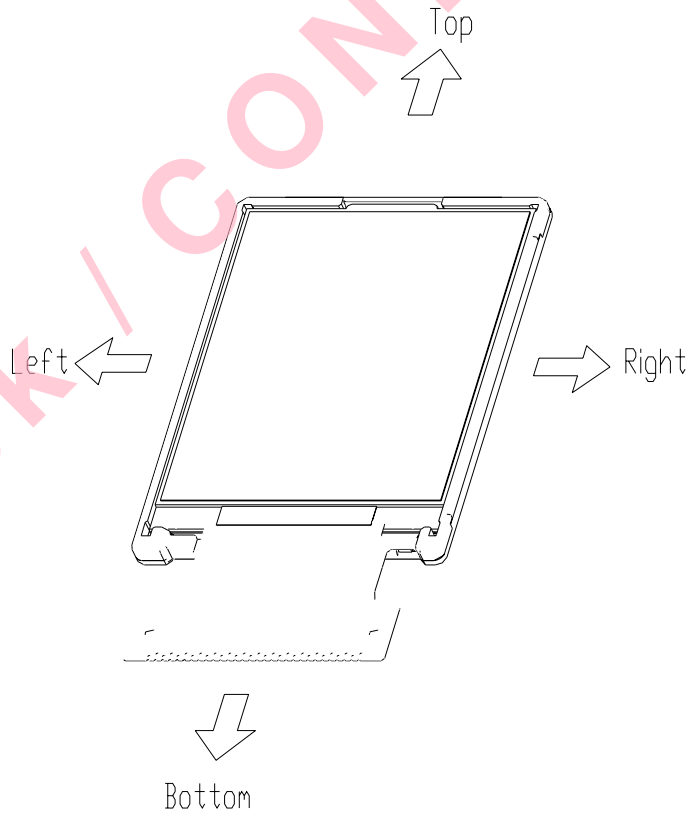

Fig. 2 Definition of viewing angle for display

Note 2: Definition of optical measurement system

The optical characteristics should be measured in a dark room with ambient temperature  $T_a=+25\text{ }^\circ\text{C}$ . The optical properties are measured at the center point of the LCD screen after 5 minutes operation. (Equipment: Photo detector TOPCON BM-5AS Field of view:  $1^\circ$ /Height: 500mm.)

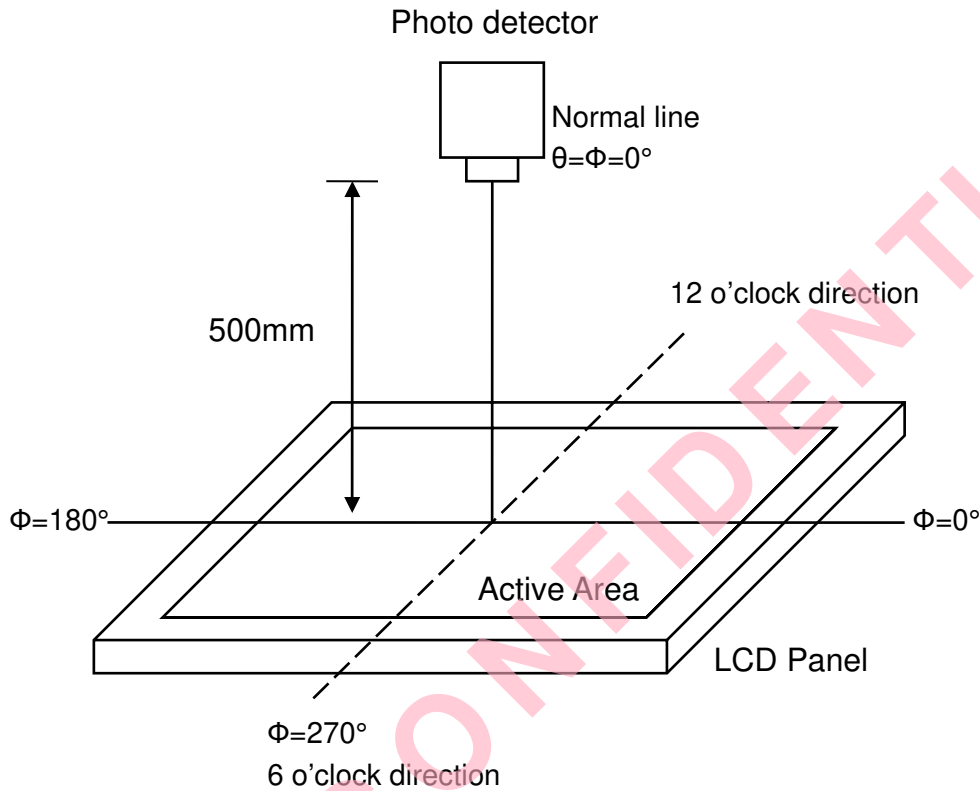

Fig. 3 Optical measurement system setup

Note 3: Definition of response time

The response time is defined as the LCD optical switching time interval between "White" state and "Black" state. Rise time ( $T_{on}$ ) is the time between photo detector output intensity changed from 90% to 10%, and fall time ( $T_{off}$ ) is the time between photo detector output intensity changed from 10% to 90%.

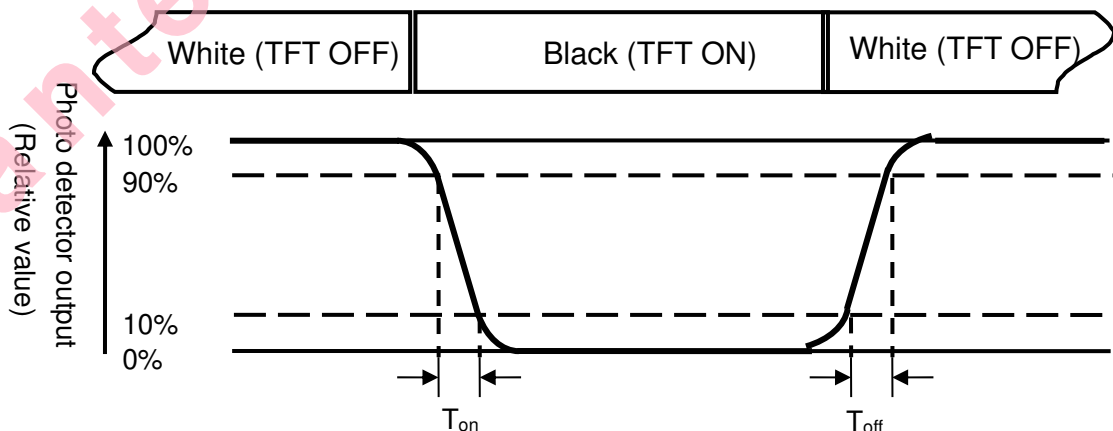

Fig. 4 Definition of response time

Note 4: Definition of contrast ratio

$$\text{Contrast ratio (CR)} = \frac{\text{Luminance measured when LCD on the "White" state}}{\text{Luminance measured when LCD on the "Black" state}}$$

Note 5: Definition of luminance

Measured at the center area of the panel when LCD panel is driven at “white” state.

Note 6: Definition of color chromaticity (CIE1931)

Color coordinates measured at the center point of LCD when panel is driven at “White”, “Red”, “Green” and “Blue” state respectively.

Note 7: Definition of luminance uniformity

To test for uniformity, the tested area is divided into 3 rows and 3 columns. The measurement spot is placed at the center of each circle as below.

$$\text{Luminance Uniformity (U}_L\text{)} = \frac{L_{\min}}{L_{\max}}$$

L-----Active area length      W----- Active area width

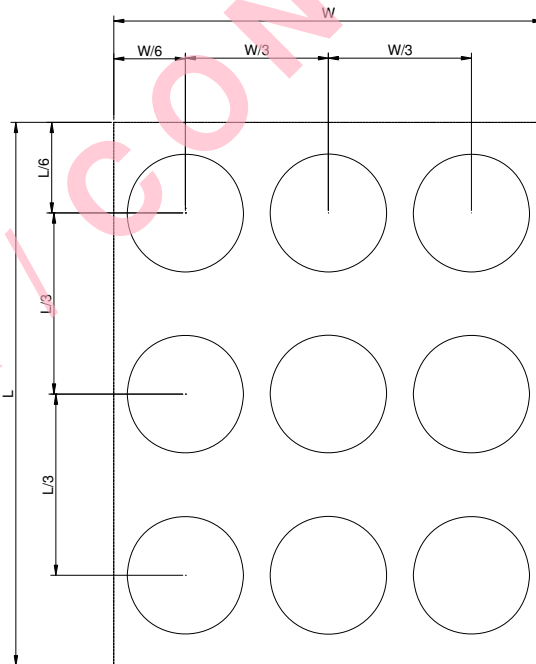

Fig. 5 Definition of luminance uniformity

$L_{\min}$  : The measured minimum luminance of all measurement position.

$L_{\max}$  : The measured maximum luminance of all measurement position.

**8. RELIABILITY TESTS**

ITEM	CONDITION	CRITERION
Operating Temperature Test	High Temperature: +70 °C±3°C, 72 hrs	No defects in display and operational functions
	Low Temperature: -20 °C±3°C, 72 hrs	
Storage Temperature Test	High Temperature: +80 °C±3°C, 120 hrs	No defects in display and operational functions
	Low Temperature: -30 °C±3°C, 120 hrs	
Humidity Endurance Test	60 °C±3°C, 90%±3%RH, 72 hrs	No defects in display and operational functions
Thermal Shock Test	-30 °C (30mins)~ +80 °C (30mins) 10 cycles	No defects in display and operational functions
Vibration Resistance Test	Operating Time: thirty minutes exposure for each direction (X,Y,Z) Sweep Frequency:10~55Hz (1 min) Amplitude: 1.5mm	No defects in display and operational functions
Mechanical Shock	100G 6ms,±X, ±Y, ±Z 3 times for each direction	No defects in display and operational functions
Electro Static Discharge	± 2KV, Human Body Mode, 100pF/1500Ω	No defects in display and operational functions

NOTE:

- 1) The samples must be free from defect before test, must be restored at room condition at least for 2 hours after reliability test before any inspection.
- 2) Before test the function of TP, the sample must be placed in room temperature for 24hrs after RA test.

---

**9. PRECAUTIONS****9.1. HANDLING**

- 9.1.1. Polarizer Cleaning, Petroleum ether (or N-hexane) is recommended for cleaning the front/rear polarizers and reflectors, acetone, toluene and ethanol are not allowed to avoid damaging the surface.
- 9.1.2. Body grounding, must wear Anti-ESD wrist strap while pick up LCDs.
- 9.1.3. FPC Soldering, less than 300°C/3S, solder must be grounding on grounding bench.
- 9.1.4. If use electric Screwdriver to do assembly, screwdriver must be grounding.

**9.2. STORAGE**

- 9.2.1. Keep in a sealed polyethylene bag.
  - 9.2.2. Keep in a dark place.
  - 9.2.3. Keep in temperature between 0°C and 35°C.
- NOT allowed at 70°C for more than 160 Hours, or at -20°C for more than 48 Hrs.

**9.3. SAFETY**

If liquid crystal leak out of a damaged glass cell, DO NOT put it in your mouth or touch eyes, if the liquid crystal touch your skin or clothes, please wash it off immediately using soap and water.

**10. LIMITED WARRANTY**

Unless otherwise agreed between San Technology and customer, San Technology will replace or repair any of its LCD modules which are found to be functionally defective when inspected in accordance with San Technology LCD acceptance standards (copies available upon request) for a period of one year from date of shipments. Cosmetic/visual defect over specs must be returned to San Technology within 30 days of shipment. Confirmation of such date shall be based on freight documents. The warranty liability of San technology limited to repair and/or replacement on the terms set forth above. San Technology shall not be responsible for any subsequent or consequential events.

**10.1. RETURNING LCM UNDER WARRANTY – TERMS AND CONDITIONS**

- 10.1.1. No warranty can be granted if the precautions stated above have been disregarded. The typical examples of violations are :
  - Broken LCD glass.
  - Circuit modified in any way, including addition of components.
- 10.1.2. Module repairs will be invoiced to the customer upon mutual agreement. Modules must be returned with sufficient description of the failures or defects. Any connectors or cable installed by the customer must be removed completely without damaging the PCB's eyelet, conductors and terminals.