

## Low loss e-starter evaluation board for compressor starter circuits based on the ACST6

Data brief

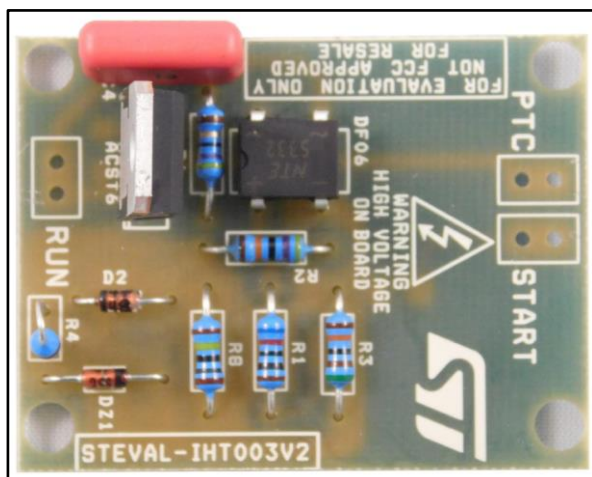

### Features

- Suitable for refrigerator and freezer compressor applications
- Reduces PTC resistor power losses
- RoHS compliant

### Description

The STEVAL-IHT003V2 evaluation board represents an innovative solution patented by STMicroelectronics to reduce the power losses caused by positive temperature coefficient (PTC) resistors in compressor starter circuits.

The solution features an ACST6 AC switch device to turn off the PTC current after motor start-up; note that the traditional PTC is still used in the electronic starter circuit as it increases circuit safety for AC switch short-circuits or diode mode failure (ref. EN60335-1).

The design reduces starter standby losses from (typ.) 2.5 W to 380 mW for 230 V applications, or 2.5 W to 40 mW for 100 V applications.

Before using the board with a compressor, the PTC behavior must be checked (especially VPTC1 and VPTC2 levels) and different R4 resistor values may be required.

# 1 Schematic diagram

Figure 1: STEVAL-IHT003V1 circuit schematic

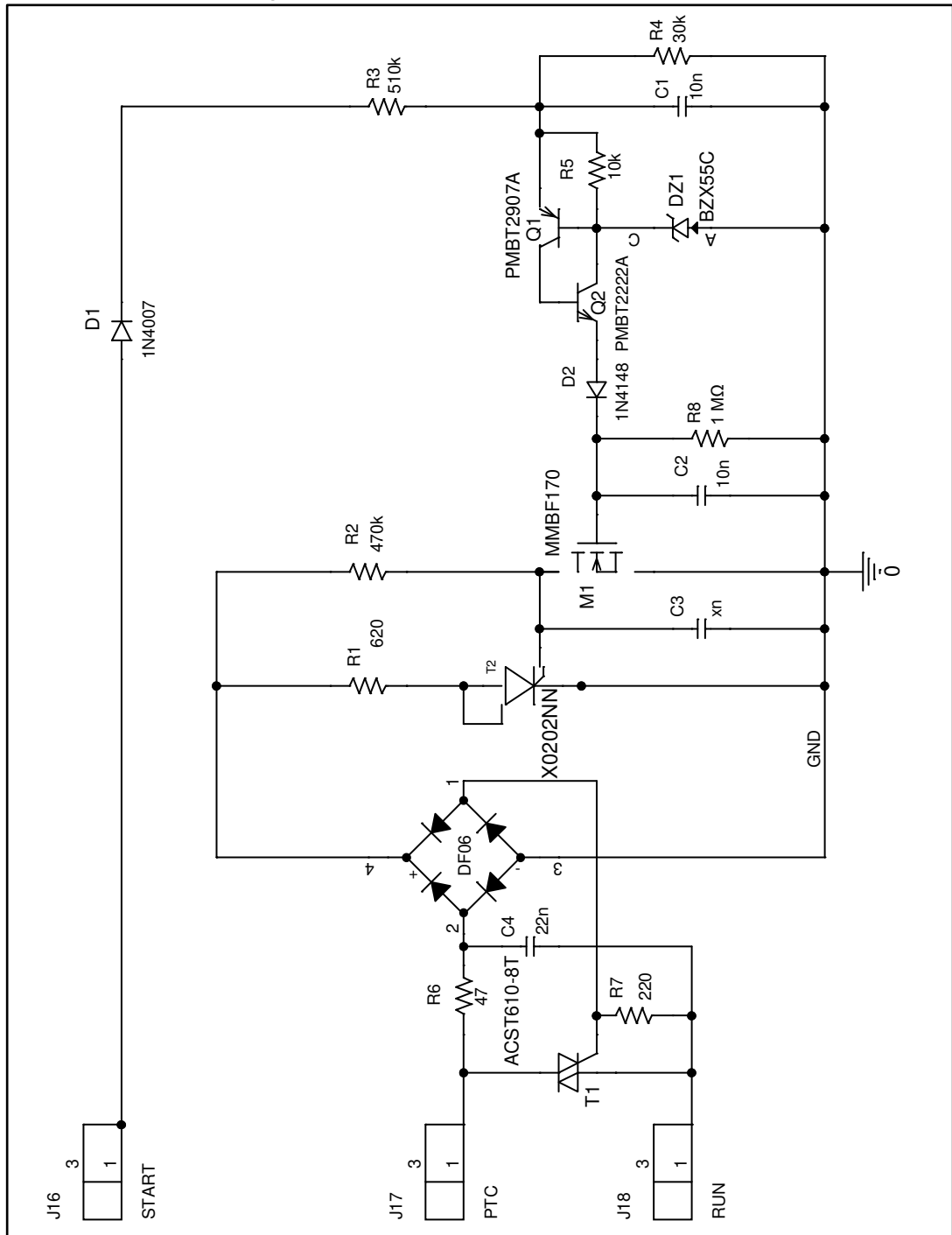

## 2 Revision history

Table 1: Document revision history

Date	Version	Changes
30-Jan-2017	1	Initial release.

**IMPORTANT NOTICE – PLEASE READ CAREFULLY**

STMicroelectronics NV and its subsidiaries ("ST") reserve the right to make changes, corrections, enhancements, modifications, and improvements to ST products and/or to this document at any time without notice. Purchasers should obtain the latest relevant information on ST products before placing orders. ST products are sold pursuant to ST's terms and conditions of sale in place at the time of order acknowledgement.

Purchasers are solely responsible for the choice, selection, and use of ST products and ST assumes no liability for application assistance or the design of Purchasers' products.

No license, express or implied, to any intellectual property right is granted by ST herein.

Resale of ST products with provisions different from the information set forth herein shall void any warranty granted by ST for such product.

ST and the ST logo are trademarks of ST. All other product or service names are the property of their respective owners.

Information in this document supersedes and replaces information previously supplied in any prior versions of this document.

© 2017 STMicroelectronics – All rights reserved