

ADS7828-Q1 12-Bit 8-Channel Sampling Analog-to-Digital Converter With I²C Interface

1 Features

- Qualified for Automotive Applications
- 8-Channel Multiplexer
- 50-kHz Sampling Rate
- No Missing Codes
- 2.7 V to 5 V Operation
- Internal 2.5-V Reference
- I²C Interface Supports Standard, Fast, and High-Speed Modes

2 Applications

- Automotive Head Units
- Heads-Up Display (HUD)
- Automotive Battery Management Systems
- Automotive On-Board Chargers
- Voltage-Supply Monitoring
- Isolated Data Acquisition
- Transducer Interfaces
- Battery-Operated Systems
- Remote Data Acquisition
- NO_x Sensors
- Soot and Particulate Matter (PM) Sensors
- Oxygen (O₂, Lambda, A/F) Sensors
- Ammonia (NH₃) Sensors
- Other Emissions and Gas Sensors

3 Description

The ADS7828 is a single-supply low-power 12-bit data acquisition device that features a serial I²C interface and an 8-channel multiplexer. The analog-to-digital converter (ADC) features a sample-and-hold amplifier and internal asynchronous clock. The combination of an I²C serial 2-wire interface and micropower consumption makes the ADS7828 ideal for applications requiring the ADC to be close to the input source in remote locations and for applications requiring isolation. The ADS7828 is available in a TSSOP-16 package.

Device Information⁽¹⁾

PART NUMBER	PACKAGE	BODY SIZE (NOM)
ADS7828-Q1	TSSOP (16)	6.40 mm × 5.00 mm

(1) For all available packages, see the orderable addendum at the end of the data sheet.

Simplified Schematic

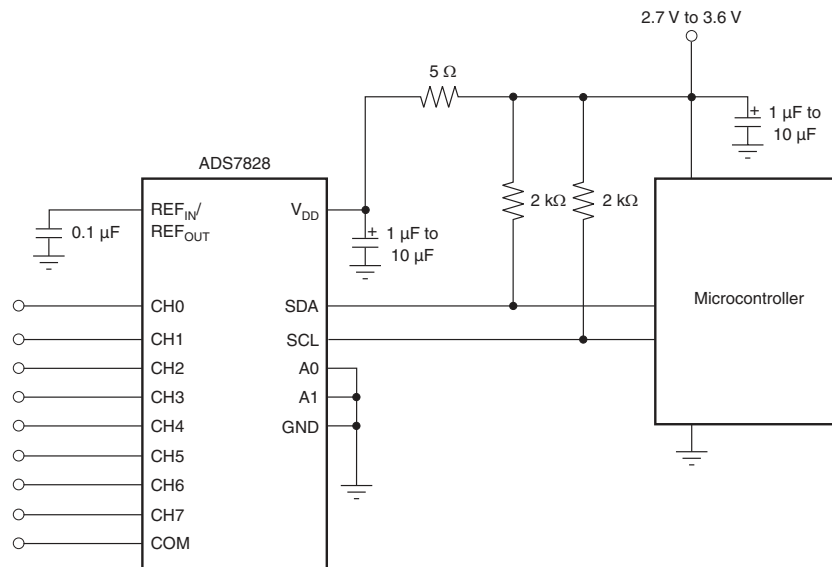

Table of Contents

1 Features	1	7.2 Functional Block Diagram	15
2 Applications	1	7.3 Feature Description	15
3 Description	1	7.4 Device Functional Modes	17
4 Revision History	2	8 Application and Implementation	22
5 Pin Configuration and Functions	3	8.1 Application Information	22
6 Specifications	4	8.2 Typical Applications	25
6.1 Absolute Maximum Ratings	4	9 Power Supply Recommendations	27
6.2 ESD Ratings	4	10 Layout	27
6.3 Recommended Operating Conditions	4	10.1 Layout Guidelines	27
6.4 Thermal Information	5	10.2 Layout Example	27
6.5 Electrical Characteristics for ADS7828E	5	11 Device and Documentation Support	28
6.6 Electrical Characteristics for ADS7828EB	6	11.1 Documentation Support	28
6.7 Electrical Characteristics for ADS7828E	8	11.2 Community Resources	28
6.8 Electrical Characteristics for ADS7828EB	9	11.3 Trademarks	28
6.9 Switching Characteristics	10	11.4 Electrostatic Discharge Caution	28
6.10 Typical Characteristics	13	11.5 Glossary	28
7 Detailed Description	15	12 Mechanical, Packaging, and Orderable Information	28
7.1 Overview	15		

4 Revision History

NOTE: Page numbers for previous revisions may differ from page numbers in the current version.

Changes from Revision A (October 2009) to Revision B	Page
<ul style="list-style-type: none"> Added <i>Device Information</i> table, <i>Thermal Information</i> table, <i>Detailed Description</i> section, <i>Application and Implementation</i> section, <i>Power Supply Recommendations</i> section, <i>Layout</i> section, <i>Device and Documentation Support</i> section, and <i>Mechanical, Packaging, and Orderable Information</i> section 	1

5 Pin Configuration and Functions

**PW Package
16-Pin TSSOP
Top View**

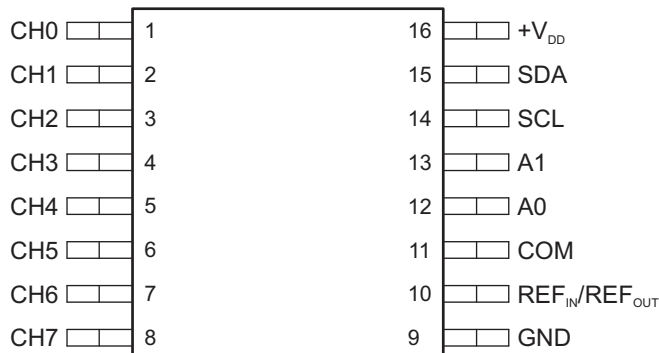

Pin Functions

PIN		DESCRIPTION
NO.	NAME	
1	CH0	Differential channel 0: positive input or single-ended channel 0 input
2	CH1	Differential channel 0: negative input or single-ended channel 1 input
3	CH2	Differential channel 1: positive input or single-ended channel 2 input
4	CH3	Differential channel 1: negative input or single-ended channel 3 input
5	CH4	Differential channel 2: positive input or single-ended channel 4 input
6	CH5	Differential channel 2: negative input or single-ended channel 5 input
7	CH6	Differential channel 3: positive input or single-ended channel 6 input
8	CH7	Differential channel 3: negative input or single-ended channel 7 input
9	GND	Analog ground
10	REF _{IN} / REF _{OUT}	Internal 2.5-V reference / external reference input
11	COM	Common to analog input channel
12	A0	Slave address bit 0
13	A1	Slave address bit 1
14	SCL	Serial clock
15	SDA	Serial data
16	+V _{DD}	Power supply, 3.3 V (nominal)

6 Specifications

6.1 Absolute Maximum Ratings

over operating free-air temperature range, unless otherwise noted. ⁽¹⁾⁽²⁾

		MIN	MAX	UNIT	
V _{DD}	Supply voltage	-0.3	6	V	
V _{IN}	Digital input voltage	-0.3	0.3	V	
θ _{JA}	Thermal impedance, junction to free air ⁽³⁾⁽⁴⁾		108.4	°C/W	
T _A	Operating free-air temperature	-40	85	°C	
T _{lead}	Lead temperature during soldering	Vapor phase (60 seconds)		215	°C
		Infrared (15 seconds)		220	°C
T _J	Operating virtual-junction temperature		150	°C	
T _{stg}	Storage temperature	-65	150	°C	

- (1) Stresses beyond those listed under *Absolute Maximum Ratings* may cause permanent damage to the device. These are stress ratings only, which do not imply functional operation of the device at these or any other conditions beyond those indicated under *Recommended Operating Conditions*. Exposure to absolute-maximum-rated conditions for extended periods may affect device reliability.
- (2) All voltages are with respect to the GND terminal.
- (3) The package thermal impedance is calculated in accordance with JESD 51-7.
- (4) Maximum power dissipation is a function of T_{J(max)}, θ_{JA}, and T_A. The maximum allowable power dissipation at any allowable ambient temperature is P_D = (T_{J(max)} - T_A)/θ_{JA}. Operating at the absolute maximum T_J of 150°C can impact reliability.

6.2 ESD Ratings

		VALUE	UNIT
V _(ESD)	Electrostatic discharge	Human-body model (HBM), per AEC Q100-002 ⁽¹⁾	±2000
		Charged-device model (CDM), per AEC Q100-011	±1000

- (1) AEC Q100-002 indicates that HBM stressing shall be in accordance with the ANSI/ESDA/JEDEC JS-001 specification.

6.3 Recommended Operating Conditions

over operating free-air temperature range (unless otherwise noted)

		MIN	NOM	MAX	UNIT
V _{DD}	Supply Voltage	2.7-V nominal	2.7	3.6	V
		5-V nominal	4.75	5	
V _{IN}	Analog Input Voltage	Positive Input	-0.2	+V _{DD} + 0.2	V
		Negative Input	-0.2	0.2	
		Full-scale differential (Positive input - Negative input)	0	V _{REF}	
V _{IN(REF)}	Voltage Reference Input voltage	0.05		+V _{DD}	V
V _{IH}	High-level digital input voltage	0.7 × +V _{DD}		+V _{DD} + 0.5	V
V _{IL}	Low-level digital input voltage	-0.3		0.3 × +V _{DD}	V
T _A	Operating free-air temperature	-40		85	°C

6.4 Thermal Information

over operating free-air temperature range (unless otherwise noted)

THERMAL METRIC ⁽¹⁾		ADS7828-Q1	UNIT
		PW (TSSOP)	
		16 PINS	
R _{θJA}	Junction-to-ambient thermal resistance	102.1	°C/W
R _{θJC(top)}	Junction-to-case (top) thermal resistance	37.2	°C/W
R _{θJB}	Junction-to-board thermal resistance	47.1	°C/W
Ψ _{JT}	Junction-to-top characterization parameter	2.9	°C/W
Ψ _{JB}	Junction-to-board characterization parameter	46.5	°C/W

(1) For more information about traditional and new thermal metrics, see the *Semiconductor and IC Package Thermal Metrics* application report, [SPRA953](#).

6.5 Electrical Characteristics for ADS7828E

+V_{DD} = 2.7 V, V_{REF} = 2.5 V, SCL clock frequency = 3.4 MHz (high-speed mode), over operating free-air temperature range, unless otherwise noted.

PARAMETER		TEST CONDITIONS	MIN	TYP	MAX	UNIT
Analog Input						
I _{leak}	Leakage current			±1		μA
C _I				25		pF
Overall Performance						
	No missing codes		12			bits
	Integral linearity error			±1	±2	LSB ⁽¹⁾
	Differential linearity error			±1		LSB
	Offset error			±1	±3	LSB
	Offset error match			±0.2	±1	LSB
	Gain error			±1	±4	LSB
	Gain error match			±0.2	±1	LSB
V _n	Noise	RMS		33		μV
PSRR	Power-supply ripple rejection			82		dB
Sampling Dynamics						
Throughput frequency	High-speed mode: SCL = 3.4 MHz			50		kHz
	Fast mode: SCL = 400 kHz			8		
	Standard mode: SCL = 100 kHz			2		
Conversion time				6		μs
AC Accuracy						
THD	Total harmonic distortion ⁽²⁾	V _{IN} = 25 V _{PP} at 10 kHz		-82		dB
	Signal-to-noise ratio	V _{IN} = 25 V _{PP} at 10 kHz		72		dB
	Signal-to-(noise + distortion) ratio	V _{IN} = 25 V _{PP} at 10 kHz		71		dB
	Spurious-free dynamic range	V _{IN} = 25 V _{PP} at 10 kHz		86		dB
	Channel-to-channel isolation			120		dB
Voltage Reference Output						
V _O	Output voltage		2.475	2.5	2.525	V
	Internal reference drift			15		ppm/°C
z _o	Output impedance	Internal reference on		110		Ω
		Internal reference off		1		GΩ
I _Q	Quiescent current			850		μA

(1) LSB means Least Significant Bit; with V_{REF} equal to 2.5 V, one LSB is 610 μV.

(2) THD is measured to the ninth harmonic.

Electrical Characteristics for ADS7828E (continued)

+V_{DD} = 2.7 V, V_{REF} = 2.5 V, SCL clock frequency = 3.4 MHz (high-speed mode), over operating free-air temperature range, unless otherwise noted.

PARAMETER		TEST CONDITIONS	MIN	TYP	MAX	UNIT
Voltage Reference Input						
r _i	Input resistance			1		GΩ
	Current drain			20		μA
Digital Input and Output						
V _{OL}	Low-level output voltage	Minimum 3-mA sink current			0.4	V
I _{IH}	High-level input current	V _{IH} = +V _{DD} + 0.5 V			10	μA
I _{IL}	Low-level input current	V _{IL} = -0.3 V	-10			μA
Power Supply						
I _Q	Quiescent current	High-speed mode: SCL = 3.4 MHz		225	320	μA
		Fast mode: SCL = 400 kHz		100		
		Standard mode: SCL = 100 kHz		60		
P _O	Power dissipation	High-speed mode: SCL = 3.4 MHz		675	1000	μW
		Fast mode: SCL = 400 kHz		300		
		Standard mode: SCL = 100 kHz		180		
	Power-down current with wrong address selected	High-speed mode: SCL = 3.4 MHz		70		μA
		Fast mode: SCL = 400 kHz		25		
		Standard mode: SCL = 100 kHz		6		
I _{PD}	Full power-down current	SCL pulled high, SDA pulled high		400	3000	nA

6.6 Electrical Characteristics for ADS7828EB

+V_{DD} = 2.7 V, V_{REF} = 2.5 V, SCL clock frequency = 3.4 MHz (high-speed mode), over operating free-air temperature range, unless otherwise noted.

PARAMETER		TEST CONDITIONS	MIN	TYP	MAX	UNIT
Analog Input						
I _{leak}	Leakage current			±1		μA
C _I				25		pF
Overall Performance						
	No missing codes		12			bits
	Integral linearity error			±0.5	±1	LSB ⁽¹⁾
	Differential linearity error			±0.5	-1 to 2	LSB
	Offset error			±0.75	±2	LSB
	Offset error match			±0.2	±1	LSB
	Gain error			±0.75	±3	LSB
	Gain error match			±0.2	±1	LSB
V _n	Noise	RMS		33		μV
PSRR	Power-supply ripple rejection			82		dB
Sampling Dynamics						
Throughput frequency		High-speed mode: SCL = 3.4 MHz			50	kHz
		Fast mode: SCL = 400 kHz			8	
		Standard mode: SCL = 100 kHz			2	
Conversion time				6		μs

(1) LSB means Least Significant Bit; with V_{REF} equal to 2.5 V, one LSB is 610 μV.

Electrical Characteristics for ADS7828EB (continued)

+V_{DD} = 2.7 V, V_{REF} = 2.5 V, SCL clock frequency = 3.4 MHz (high-speed mode), over operating free-air temperature range, unless otherwise noted.

PARAMETER		TEST CONDITIONS	MIN	TYP	MAX	UNIT
AC Accuracy						
THD	Total harmonic distortion ⁽²⁾	V _{IN} = 25 V _{PP} at 10 kHz		-82		dB
	Signal-to-noise ratio	V _{IN} = 25 V _{PP} at 10 kHz		72		dB
	Signal-to-(noise + distortion) ratio	V _{IN} = 25 V _{PP} at 10 kHz		71		dB
	Spurious-free dynamic range	V _{IN} = 25 V _{PP} at 10 kHz		86		dB
	Channel-to-channel isolation			120		dB
Voltage Reference Output						
V _O	Output voltage		2.475	2.5	2.525	V
	Internal reference drift			15		ppm/°C
z _o	Output impedance	Internal reference on		110		Ω
		Internal reference off		1		GΩ
I _Q	Quiescent current			850		μA
Voltage Reference Input						
r _I	Input resistance			1		GΩ
	Current drain			20		μA
Digital Input and Output						
V _{OL}	Low-level output voltage	Minimum 3-mA sink current			0.4	V
I _{IH}	High-level input current	V _{IH} = +V _{DD} + 0.5 V			10	μA
I _{IL}	Low-level input current	V _{IL} = -0.3 V	-10			μA
Power Supply						
I _Q	Quiescent current	High-speed mode: SCL = 3.4 MHz		225	320	μA
		Fast mode: SCL = 400 kHz		100		
		Standard mode: SCL = 100 kHz		60		
P _O	Power dissipation	High-speed mode: SCL = 3.4 MHz		675	1000	μW
		Fast mode: SCL = 400 kHz		300		
		Standard mode: SCL = 100 kHz		180		
	Power-down current with wrong address selected	High-speed mode: SCL = 3.4 MHz		70		μA
		Fast mode: SCL = 400 kHz		25		
		Standard mode: SCL = 100 kHz		6		
I _{PD}	Full power-down current	SCL pulled high, SDA pulled high		400	3000	nA

(2) THD is measured to the ninth harmonic.

6.7 Electrical Characteristics for ADS7828E

+V_{DD} = 5 V, V_{REF} = External 5 V, SCL clock frequency = 3.4 MHz (high-speed mode), over operating free-air temperature range, unless otherwise noted.

PARAMETER		TEST CONDITIONS	MIN	TYP	MAX	UNIT
Analog Input						
I _{leak}	Leakage current			±1		μA
C _I				25		pF
Overall Performance						
	No missing codes		12			bits
	Integral linearity error			±1	±2	LSB ⁽¹⁾
	Differential linearity error			±1		LSB
	Offset error			±1	±3	LSB
	Offset error match				±1.5	LSB
	Gain error			±1	±3	LSB
	Gain error match				±1	LSB
V _n	Noise	RMS		33		μV
PSRR	Power-supply ripple rejection			82		dB
Sampling Dynamics						
Throughput frequency	High-speed mode: SCL = 3.4 MHz				50	kHz
	Fast mode: SCL = 400 kHz				8	
	Standard mode: SCL = 100 kHz				2	
Conversion time				6		μs
AC Accuracy						
THD	Total harmonic distortion ⁽²⁾	V _{IN} = 25 V _{PP} at 10 kHz		-82		dB
	Signal-to-noise ratio	V _{IN} = 25 V _{PP} at 10 kHz		72		dB
	Signal-to-(noise + distortion) ratio	V _{IN} = 25 V _{PP} at 10 kHz		71		dB
	Spurious-free dynamic range	V _{IN} = 25 V _{PP} at 10 kHz		86		dB
	Channel-to-channel isolation			120		dB
Voltage Reference Output						
V _O	Output voltage		2.475	2.5	2.525	V
	Internal reference drift			15		ppm/°C
z _o	Output impedance	Internal reference on		110		Ω
		Internal reference off		1		GΩ
I _Q	Quiescent current			1300		μA
Voltage Reference Input						
r _I	Input resistance			1		GΩ
	Current drain			20		μA
Digital Input and Output						
V _{OL}	Low-level output voltage	Minimum 3-mA sink current			0.4	V
I _{IH}	High-level input current	V _{IH} = +V _{DD} + 0.5 V			10	μA
I _{IL}	Low-level input current	V _{IL} = -0.3 V	-10			μA

(1) LSB means Least Significant Bit; with V_{REF} equal to 5 V, one LSB is 1.22 mV.

(2) THD is measured to the ninth harmonic.

Electrical Characteristics for ADS7828E (continued)

+V_{DD} = 5 V, V_{REF} = External 5 V, SCL clock frequency = 3.4 MHz (high-speed mode), over operating free-air temperature range, unless otherwise noted.

PARAMETER		TEST CONDITIONS	MIN	TYP	MAX	UNIT
Power Supply						
I _Q	Quiescent current	High-speed mode: SCL = 3.4 MHz		750	100	μA
		Fast mode: SCL = 400 kHz		300		
		Standard mode: SCL = 100 kHz		150		
P _O	Power dissipation	High-speed mode: SCL = 3.4 MHz		3.75	5	μW
		Fast mode: SCL = 400 kHz		1.5		
		Standard mode: SCL = 100 kHz		0.75		
I _{PD}	Power-down current with wrong address selected	High-speed mode: SCL = 3.4 MHz		400		μA
		Fast mode: SCL = 400 kHz		150		
		Standard mode: SCL = 100 kHz		35		
I _{PD}	Full power-down current	SCL pulled high, SDA pulled high		400	3000	nA

6.8 Electrical Characteristics for ADS7828EB

+V_{DD} = 5 V, V_{REF} = External 5 V, SCL clock frequency = 3.4 MHz (high-speed mode), over operating free-air temperature range, unless otherwise noted.

PARAMETER		TEST CONDITIONS	MIN	TYP	MAX	UNIT
Analog Input						
I _{leak}	Leakage current			±1		μA
C _I				25		pF
Overall Performance						
	No missing codes		12			bits
	Integral linearity error			±0.5	±1	LSB ⁽¹⁾
	Differential linearity error			±0.5	-1 to 2	LSB
	Offset error			±0.75	±2	LSB
	Offset error match				±1	LSB
	Gain error			±0.75	±2	LSB
	Gain error match				±1	LSB
V _n	Noise	RMS		33		μV
PSRR	Power-supply ripple rejection			82		dB
Sampling Dynamics						
Throughput frequency		High-speed mode: SCL = 3.4 MHz			50	kHz
		Fast mode: SCL = 400 kHz			8	
		Standard mode: SCL = 100 kHz			2	
Conversion time				6		μs
AC Accuracy						
THD	Total harmonic distortion ⁽²⁾	V _{IN} = 25 V _{PP} at 10 kHz		-82		dB
	Signal-to-noise ratio	V _{IN} = 25 V _{PP} at 10 kHz		72		dB
	Signal-to-(noise + distortion) ratio	V _{IN} = 25 V _{PP} at 10 kHz		71		dB
	Spurious-free dynamic range	V _{IN} = 25 V _{PP} at 10 kHz		86		dB
	Channel-to-channel isolation			120		dB

(1) LSB means Least Significant Bit; with V_{REF} equal to 5 V, one LSB is 1.22 mV.

(2) THD is measured to the ninth harmonic.

Electrical Characteristics for ADS7828EB (continued)

+V_{DD} = 5 V, V_{REF} = External 5 V, SCL clock frequency = 3.4 MHz (high-speed mode), over operating free-air temperature range, unless otherwise noted.

PARAMETER		TEST CONDITIONS	MIN	TYP	MAX	UNIT
Voltage Reference Output						
V _O	Output voltage		2.475	2.5	2.525	V
	Internal reference drift			15		ppm/°C
z _o	Output impedance	Internal reference on		110		Ω
		Internal reference off		1		GΩ
I _Q	Quiescent current			1300		μA
Voltage Reference Input						
r _i	Input resistance			1		GΩ
	Current drain			20		μA
Digital Input and Output						
V _{OL}	Low-level output voltage	Minimum 3-mA sink current			0.4	V
I _{IH}	High-level input current	V _{IH} = +V _{DD} + 0.5 V			10	μA
I _{IL}	Low-level input current	V _{IL} = -0.3 V	-10			μA
Power Supply						
I _Q	Quiescent current	High-speed mode: SCL = 3.4 MHz		750	1000	μA
		Fast mode: SCL = 400 kHz		300		
		Standard mode: SCL = 100 kHz		150		
P _O	Power dissipation	High-speed mode: SCL = 3.4 MHz		3.75	5	μW
		Fast mode: SCL = 400 kHz		1.5		
		Standard mode: SCL = 100 kHz		0.75		
I _{PD}	Power-down current with wrong address selected	High-speed mode: SCL = 3.4 MHz		400		μA
		Fast mode: SCL = 400 kHz		150		
		Standard mode: SCL = 100 kHz		35		
I _{PD}	Full power-down current	SCL pulled high, SDA pulled high		400	3000	nA

6.9 Switching Characteristics

+V_{DD} = 2.7 V, over operating free-air temperature range, unless otherwise noted.⁽¹⁾⁽²⁾ See [Figure 1](#).

PARAMETER		TEST CONDITIONS	MIN	MAX	UNIT	
f _{SCL}	SCL clock frequency	Standard mode		100	kHz	
		Fast mode		400		
		High-speed mode	C _b = 100 pF max		3.4	MHz
			C _b = 400 pF max		1.7	
t _{BUF}	Bus free time between Stop and Start conditions	Standard mode	4.7		μs	
		Fast mode	1.3			
t _{HD; STA}	Hold time (repeated) Start condition	Standard mode	4		μs	
		Fast mode	600		ns	
		High-speed mode	160			
t _{low}	Low period of the SCL clock	Standard mode	4.7		μs	
		Fast mode	1.3			
		High-speed mode ⁽³⁾	C _b = 100 pF max	160		ns
			C _b = 400 pF max	320		

(1) All values referred to V_{IH(MIN)} and V_{IL(MAX)} levels.

(2) Not production tested, except for the parameter t_{HD; DAT}, data hold time, high-speed mode, C_b = 100 pF max.

(3) For bus line loads (C_B) between 100 pF and 400 pF, the timing parameters must be linearly interpolated.

Switching Characteristics (continued)

 +V_{DD} = 2.7 V, over operating free-air temperature range, unless otherwise noted.⁽¹⁾⁽²⁾ See [Figure 1](#).

PARAMETER		TEST CONDITIONS		MIN	MAX	UNIT
t _{high}	High period of the SCL clock	Standard mode		4		μs
		Fast mode		600		ns
		High-speed mode ⁽³⁾	C _b = 100 pF max	60		
			C _b = 400 pF max	120		
t _{SU; STA}	Setup time for a repeated Start condition	Standard mode		4.7		μs
		Fast mode		600		ns
		High-speed mode		160		
t _{SU; DAT}	Data setup time	Standard mode		250		ns
		Fast mode		100		
		High-speed mode		10		
t _{HD; DAT}	Data hold time	Standard mode		0	3.45	μs
		Fast mode		0	0.9	
		High-speed mode ^{(3) (4)}	C _b = 100 pF max	0	82	ns
			C _b = 400 pF max	0	162	
t _{rCL}	Rise time of SCL signal	Standard mode			1000	ns
		Fast mode		20 + 0.1C _b	300	
		High-speed mode ⁽³⁾	C _b = 100 pF max	10	40	
			C _b = 400 pF max	20	80	
t _{rCL1}	Rise time of SCL signal after a repeated Start condition and after an acknowledge bit	Standard mode			1000	ns
		Fast mode		20 + 0.1C _b	300	
		High-speed mode ⁽³⁾	C _b = 100 pF max	10	80	
			C _b = 400 pF max	20	160	
t _{fCL}	Fall time of SCL signal	Standard mode			300	ns
		Fast mode		20 + 0.1C _b	300	
		High-speed mode ⁽³⁾	C _b = 100 pF max	10	40	
			C _b = 400 pF max	20	80	
t _{rDA}	Rise time of SDA signal	Standard mode			1000	ns
		Fast mode		20 + 0.1C _b	300	
		High-speed mode ⁽³⁾	C _b = 100 pF max	10	80	
			C _b = 400 pF max	20	160	
t _{fDA}	Fall time of SDA signal	Standard mode			300	ns
		Fast mode		20 + 0.1C _b	300	
		High-speed mode ⁽³⁾	C _b = 100 pF max	10	80	
			C _b = 400 pF max	20	160	
t _{SU; STO}	Setup time for Stop condition	Standard mode		4		μs
		Fast mode		600		ns
		High-speed mode		160		
C _b	Capacitive load for SDA or SCL				400	pF
t _{SP}	Pulse width of spike suppressed	Fast mode			50	ns
		High-speed mode			10	
V _{nH}	Noise margin at the high level for each connected device (including hysteresis)			0.2 × V _{DD}		V
V _{nL}	Noise margin at the low level for each connected device (including hysteresis)			0.1 × V _{DD}		V

(4) A device must internally provide a data hold time to bridge the undefined part between V_{IH} and V_{IL} of the falling edge of the SCLH signal. An input circuit with a threshold as low as possible for the falling edge of the SCLH signal minimizes this hold time.

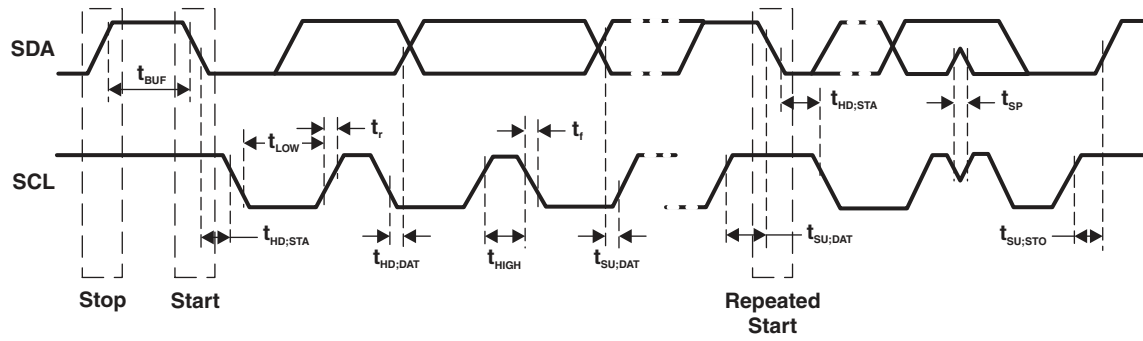

Figure 1. I²C Timing

6.10 Typical Characteristics

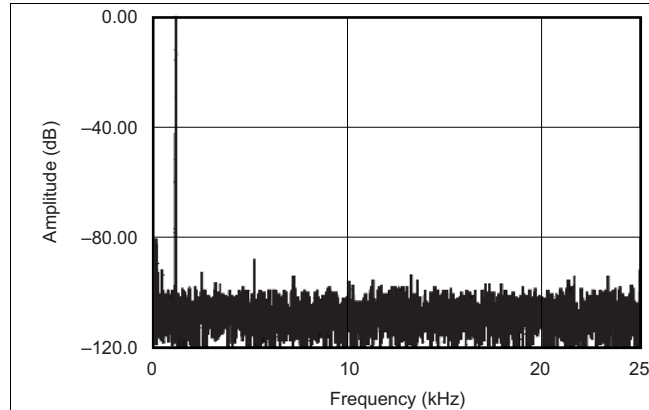

Figure 2. Frequency Spectrum
(4096 Point FFT: $f_{IN} = 1$ kHz, 0 dB)

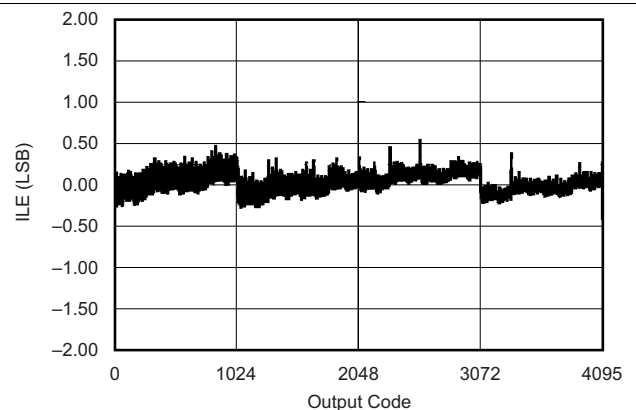

Figure 3. Integral Linearity Error vs Code
(2.5-V Internal Reference)

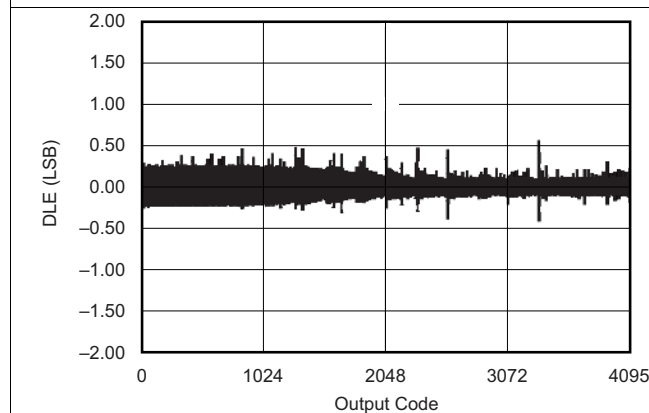

Figure 4. Differential Linearity Error vs Code
(2.5-V Internal Reference)

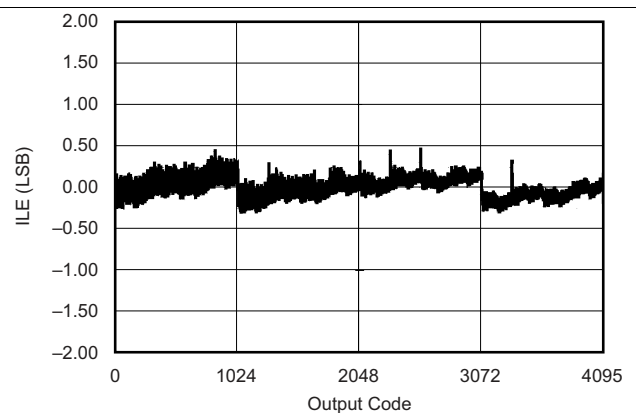

Figure 5. Integral Linearity Error vs Code
(2.5-V External Reference)

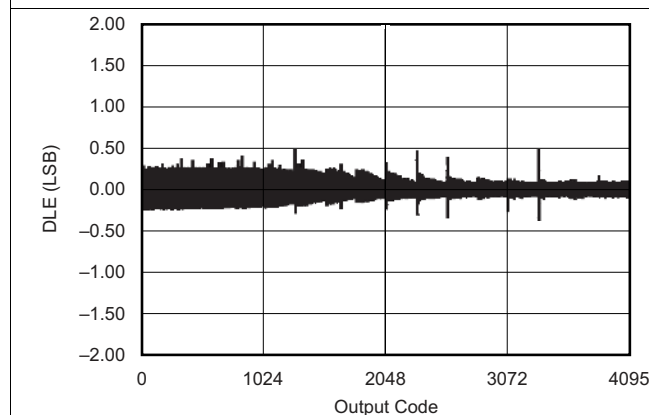

Figure 6. Differential Linearity Error vs Code
(2.5-V External Reference)

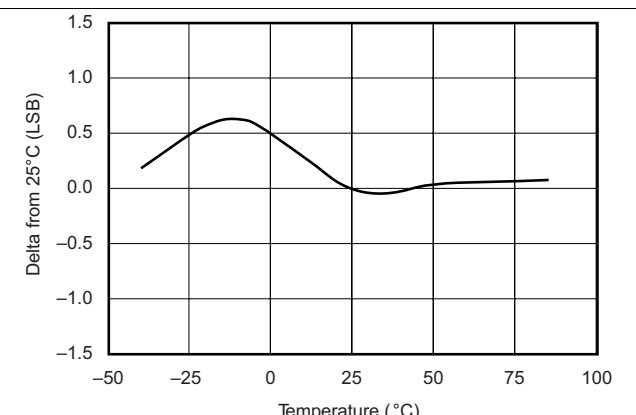

Figure 7. Change in Offset vs Temperature

Typical Characteristics (continued)

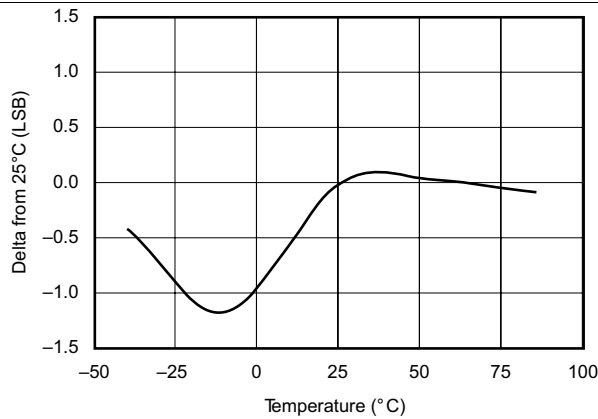

Figure 8. Change in Gain vs Temperature

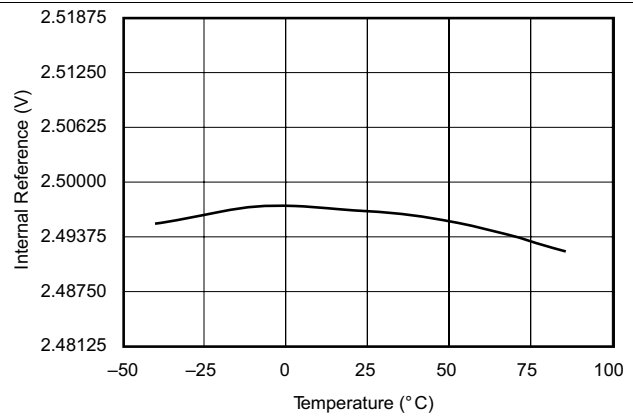

Figure 9. Internal Reference vs Temperature

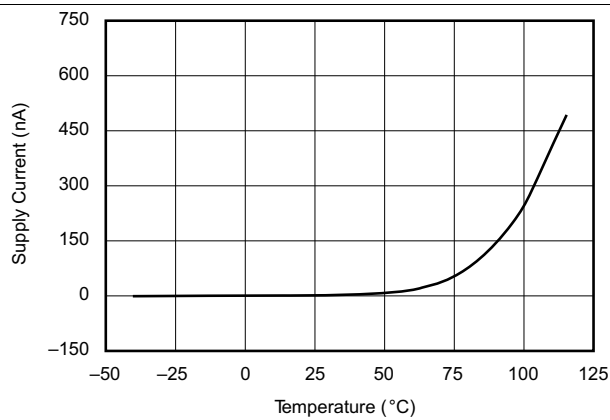

Figure 10. Power-Down Supply Current vs Temperature

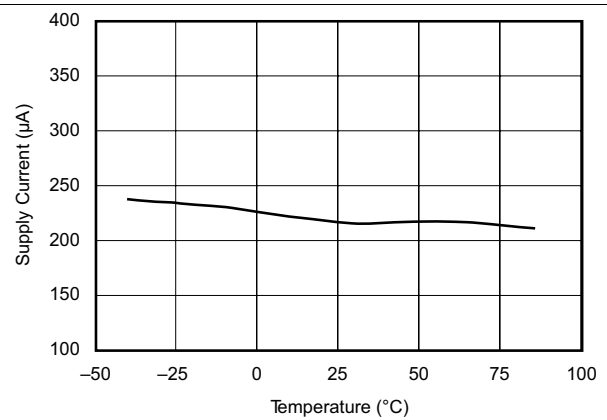

Figure 11. Supply Current vs Temperature

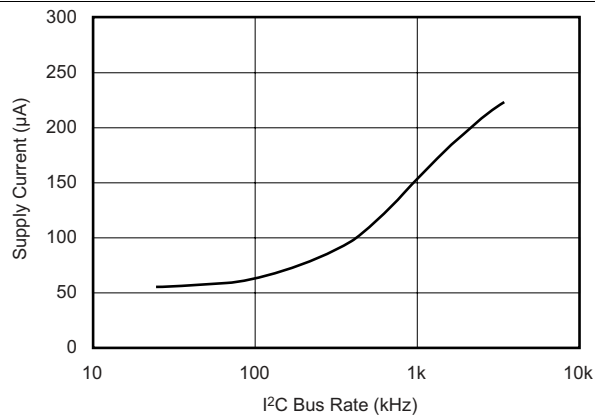

Figure 12. Supply Current vs I²C Bus Rate

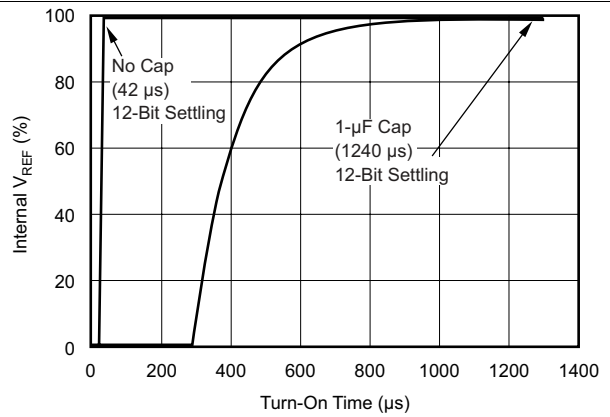

Figure 13. Internal VREF vs Turn-On Time

7 Detailed Description

7.1 Overview

The ADS7828 is a classic Successive Approximation Register (SAR) ADC. The architecture is based on capacitive redistribution which inherently includes a sample-and-hold function. The converter is fabricated on a 0.6 μ m CMOS process.

The ADS7828 core is controlled by an internally generated free-running clock. When the ADS7828 is not performing conversions or being addressed, it keeps the ADC core powered off, and the internal clock does not operate.

7.2 Functional Block Diagram

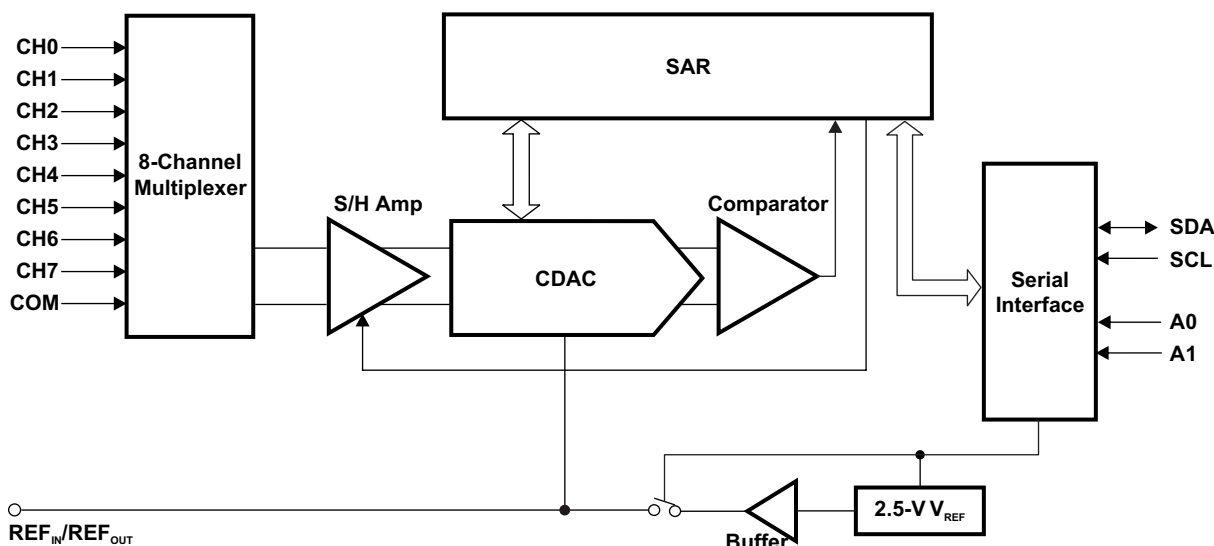

7.3 Feature Description

7.3.1 Analog Input

When the converter enters the hold mode, the voltage on the selected CH_x pin is captured on the internal capacitor array. The input current on the analog inputs depends on the conversion rate of the device. During the sample period, the source must charge the internal sampling capacitor (typically 25 pF). After the capacitor has been fully charged, there is no further input current. The amount of charge transfer from the analog source to the converter is a function of conversion rate.

7.3.2 Reference

The ADS7828 can operate with an internal 2.5-V reference or an external reference. If a 5-V supply is used, an external 5-V reference is required in order to provide full dynamic range for a 0 V to +V_{DD} analog input. This external reference can be as low as 50 mV. When using a 2.7-V supply, the internal 2.5-V reference will provide full dynamic range for a 0 V to +V_{DD} analog input.

As the reference voltage is reduced, the analog voltage weight of each digital output code is reduced. This is often referred to as the LSB (least significant bit) size and is equal to the reference voltage divided by 4096. This means that any offset or gain error inherent in the ADC will appear to increase, in terms of LSB size, as the reference voltage is reduced.

The noise inherent in the converter will also appear to increase with lower LSB size. With a 2.5-V reference, the internal noise of the converter typically contributes only 0.32 LSB peak-to-peak of potential error to the output code. When the external reference is 50 mV, the potential error contribution from the internal noise is 50 times larger—16 LSBs. The errors due to the internal noise are Gaussian in nature and can be reduced by averaging consecutive conversion results.

Feature Description (continued)

7.3.3 Digital Interface

The ADS7828 supports the I²C serial bus and data transmission protocol, in all three defined modes: standard, fast, and high-speed. A device that sends data onto the bus is defined as a transmitter, and a device receiving data as a receiver. The device that controls the message is called a master. The devices that are controlled by the master are slaves. The bus must be controlled by a master device that generates the serial clock (SCL), controls the bus access, and generates the Start and Stop conditions. The ADS7828 operates as a slave on the I²C bus. Connections to the bus are made via the open-drain I/O lines SDA and SCL.

The following bus protocol has been defined (see [Figure 14](#)):

- Data transfer may be initiated only when the bus is not busy.
- During data transfer, the data line must remain stable whenever the clock line is high. Changes in the data line while the clock line is high will be interpreted as control signals.

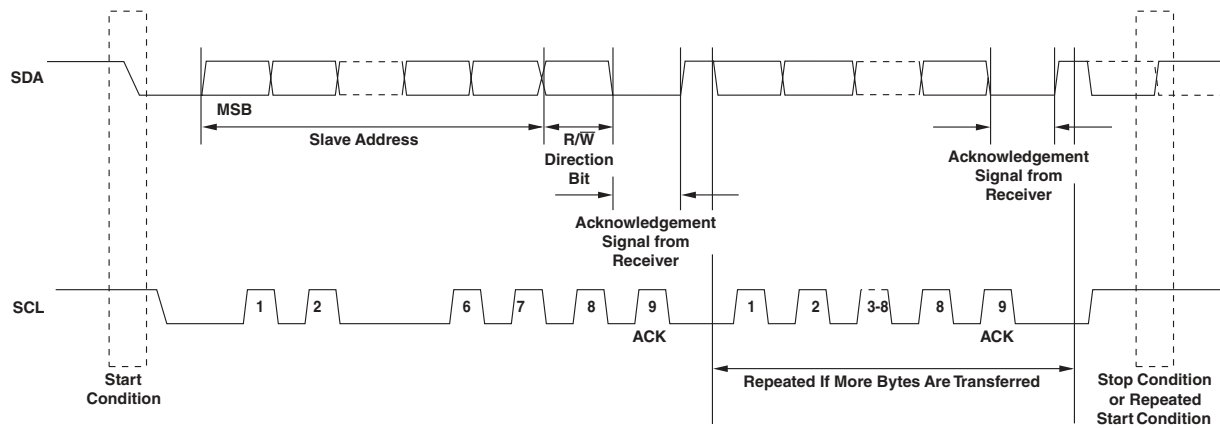

Figure 14. Basic Operation

Accordingly, the following bus conditions have been defined:

- **Bus Not Busy**
Both data and clock lines remain high.
- **Start Data Transfer**
A change in the state of the data line, from high to low, while the clock is high, defines a Start condition.
- **Stop Data Transfer**
A change in the state of the data line, from low to high, while the clock line is high, defines the Stop condition.
- **Data Valid**
The state of the data line represents valid data, when, after a Start condition, the data line is stable for the duration of the high period of the clock signal. There is one clock pulse per bit of data.
Each data transfer is initiated with a Start condition and terminated with a Stop condition. The number of data bytes transferred between Start and Stop conditions is not limited and is determined by the master device. The information is transferred byte-wise and each receiver acknowledges with a ninth-bit.
- **Acknowledge**
Within the I²C bus specifications a standard mode (100-kHz clock rate), a fast mode (400-kHz clock rate), and a highspeed mode (3.4-MHz clock rate) are defined. The ADS7828 works in all three modes.
Each receiving device, when addressed, is obliged to generate an acknowledge after the reception of each byte. The master device must generate an extra clock pulse that is associated with this acknowledge bit.
A device that acknowledges must pull down the SDA line during the acknowledge clock pulse in such a way that the SDA line is stable low during the high period of the acknowledge clock pulse. Of course, setup and hold times must be taken into account. A master must signal an end of data to the slave by not generating an acknowledge bit on the last byte that has been clocked out of the slave. In this case, the slave must leave the data line high to enable the master to generate the Stop condition.

Feature Description (continued)

Figure 14 shows how data transfer is accomplished on the I²C bus. Depending upon the state of the R/W bit, two types of data transfer are possible:

- Data transfer from a master transmitter to a slave receiver.
The first byte transmitted by the master is the slave address. Next follows a number of data bytes. The slave returns an acknowledge bit after the slave address and each received byte.
- Data transfer from a slave transmitter to a master receiver.
The first byte, the slave address, is transmitted by the master. The slave then returns an acknowledge bit. Next, a number of data bytes are transmitted by the slave to the master. The master returns an acknowledge bit after all received bytes other than the last byte. At the end of the last received byte, a not-acknowledge is returned.

The master device generates all of the serial clock pulses and the Start and Stop conditions. A transfer is ended with a Stop condition or a repeated Start condition. Since a repeated Start condition is also the beginning of the next serial transfer, the bus will not be released.

7.4 Device Functional Modes

The ADS7828 may operate in the following two modes:

- Slave Receiver Mode
Serial data and clock are received through SDA and SCL. After each byte is received, an acknowledge bit is transmitted. Start and Stop conditions are recognized as the beginning and end of a serial transfer. Address recognition is performed by hardware after reception of the slave address and direction bit.
- Slave Transmitter Mode
The first byte (the slave address) is received and handled as in the slave receiver mode. However, in this mode the direction bit will indicate that the transfer direction is reversed. Serial data is transmitted on SDA by the ADS7828 while the serial clock is input on SCL. Start and Stop conditions are recognized as the beginning and end of a serial transfer.

7.4.1 Address Byte

The address byte is the first byte received following the Start condition from the master device (see Figure 15). The first five bits (MSBs) of the slave address are factory pre-set to 10010. The next two bits of the address byte are the device select bits, A1 and A0. Input pins (A1-A0) on the ADS7828 determine these two bits of the device address for a particular ADS7828. A maximum of four devices with the same pre-set code can therefore be connected on the same bus at one time.

Figure 15. Address Byte

MSB	6	5	4	3	2	1	LSB
1	0	0	1	0	A1	A0	R/W

The A1 and A0 address inputs can be connected to V_{DD} or digital ground. The device address is set by the state of these pins upon power-up.

The last bit of the address byte (R/W) defines the operation to be performed. When set to a 1, a read operation is selected; when set to a 0, a write operation is selected. Following the Start condition, the ADS7828 monitors the SDA bus, checking the device type identifier being transmitted. Upon receiving the 10010 code, the appropriate device select bits, and the R/W bit, the slave device outputs an acknowledge signal on the SDA line.

7.4.2 Command Byte

The operating mode is determined by a command byte (see [Figure 16](#)).

Figure 16. Command Byte

MSB	6	5	4	3	2	1	LSB
SD	C2	C1	C0	PD1	PD0	X	X

SD: Single-ended or differential inputs

0 = Differential inputs

1 = Single-ended inputs

C2 to C0: Channel selections (see [Table 1](#))

PD1, PD0: Power-down selection (see [Table 2](#))

X: Unused

Table 1. Channel Selection Control Addressed by Command Byte

COMMAND BYTE INPUTS				CHANNEL SELECTIONS								
SD	C2	C1	C0	CH0	CH1	CH2	CH3	CH4	CH5	CH6	CH7	COM
0	0	0	0	+IN	-IN	—	—	—	—	—	—	—
0	0	0	1	—	—	+IN	-IN	—	—	—	—	—
0	0	1	0	—	—	—	—	+IN	-IN	—	—	—
0	0	1	1	—	—	—	—	—	—	+IN	-IN	—
0	1	0	0	-IN	+IN	—	—	—	—	—	—	—
0	1	0	1	—	—	-IN	+IN	—	—	—	—	—
0	1	1	0	—	—	—	—	-IN	+IN	—	—	—
0	1	1	1	—	—	—	—	—	—	-IN	+IN	—
1	0	0	0	+IN	—	—	—	—	—	—	—	-IN
1	0	0	1	—	—	+IN	—	—	—	—	—	-IN
1	0	1	0	—	—	—	—	+IN	—	—	—	-IN
1	0	1	1	—	—	—	—	—	—	+IN	—	-IN
1	1	0	0	—	+IN	—	—	—	—	—	—	-IN
1	1	0	1	—	—	—	+IN	—	—	—	—	-IN
1	1	1	0	—	—	—	—	—	+IN	—	—	-IN
1	1	1	1	—	—	—	—	—	—	—	+IN	-IN

Table 2. Power-Down Selection

PD1	PD0	DESCRIPTION
0	0	Power down between ADC conversions
0	1	Internal reference off and ADC on
1	0	Internal reference on and ADC off
1	1	Internal reference on and ADC on

7.4.3 Initiating Conversion

Provided the master has write-addressed it, the ADS7828 turns on the ADC section and begins conversions when it receives bit 4 of the command byte shown in [Figure 16](#). If the command byte is correct, the ADS7828 returns an ACK condition.

7.4.4 Reading Data

Data can be read from the ADS7828 by read addressing the part (LSB of address byte set to 1) and receiving the transmitted bytes. Converted data can be read from the ADS7828 only after a conversion has been initiated as described in the preceding section.

Each 12-bit data word is returned in two bytes (see Figure 17), where D11 is the MSB of the data word, and D0 is the LSB. Byte 0 is sent first, followed by byte 1.

Figure 17. Reading Data

	MSB	6	5	4	3	2	1	LSB
Byte 0	0	0	0	0	D11	D10	D9	D8
Byte 1	D7	D6	D5	D4	D3	D2	D1	D0

7.4.5 Reading in Fast or Standard (F/S) Mode

Figure 18 shows the interaction between the master and the slave ADS7828 in fast or standard (F/S) mode. At the end of reading conversion data, the ADS7828 can be issued a repeated Start condition by the master to secure bus operation for subsequent conversions of the ADC. This would be the most efficient way to perform continuous conversions.

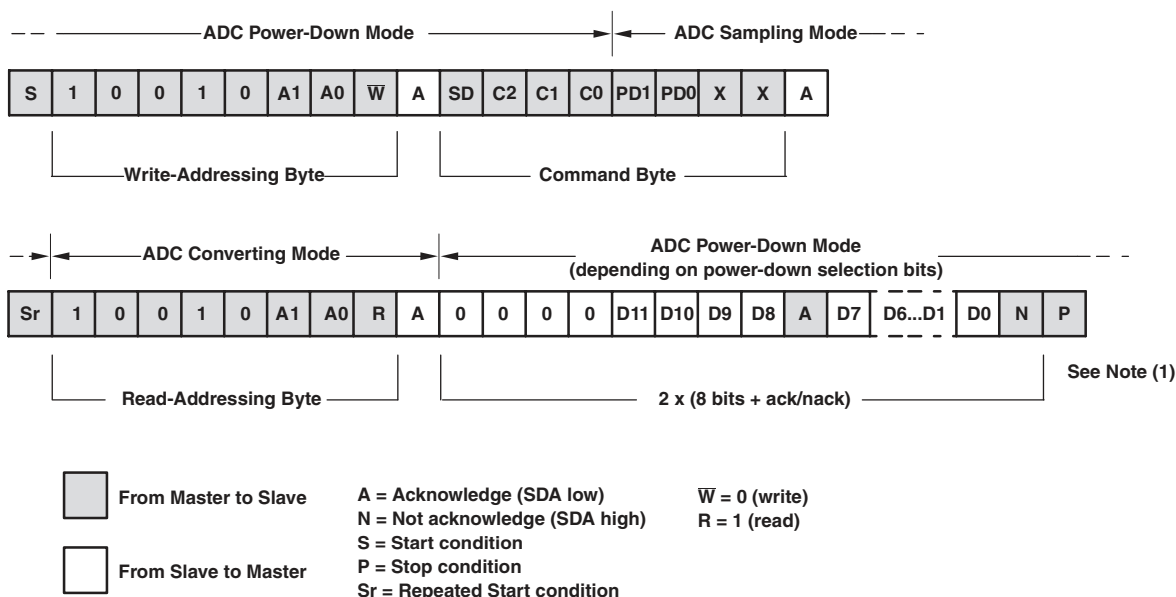

NOTE: (1) To secure bus operation and loop back to the stage of write-addressing for next conversion, use Repeated Start.

Figure 18. Typical Read Sequence in F/S Mode

7.4.6 Reading in High-Speed (HS) Mode

High Speed (HS) mode is fast enough that codes can be read out one at a time. In HS mode, there is not enough time for a single conversion to complete between the reception of a repeated Start condition and the read-addressing byte, so the ADS7828 stretches the clock after the read-addressing byte has been fully received, holding it low until the conversion is complete.

See Figure 19 for a typical read sequence for HS mode. Included in the read sequence is the shift from F/S to HS modes. It may be desirable to remain in HS mode after reading a conversion; to do this, issue a repeated Start instead of a Stop at the end of the read sequence, since a Stop causes the part to return to F/S mode.

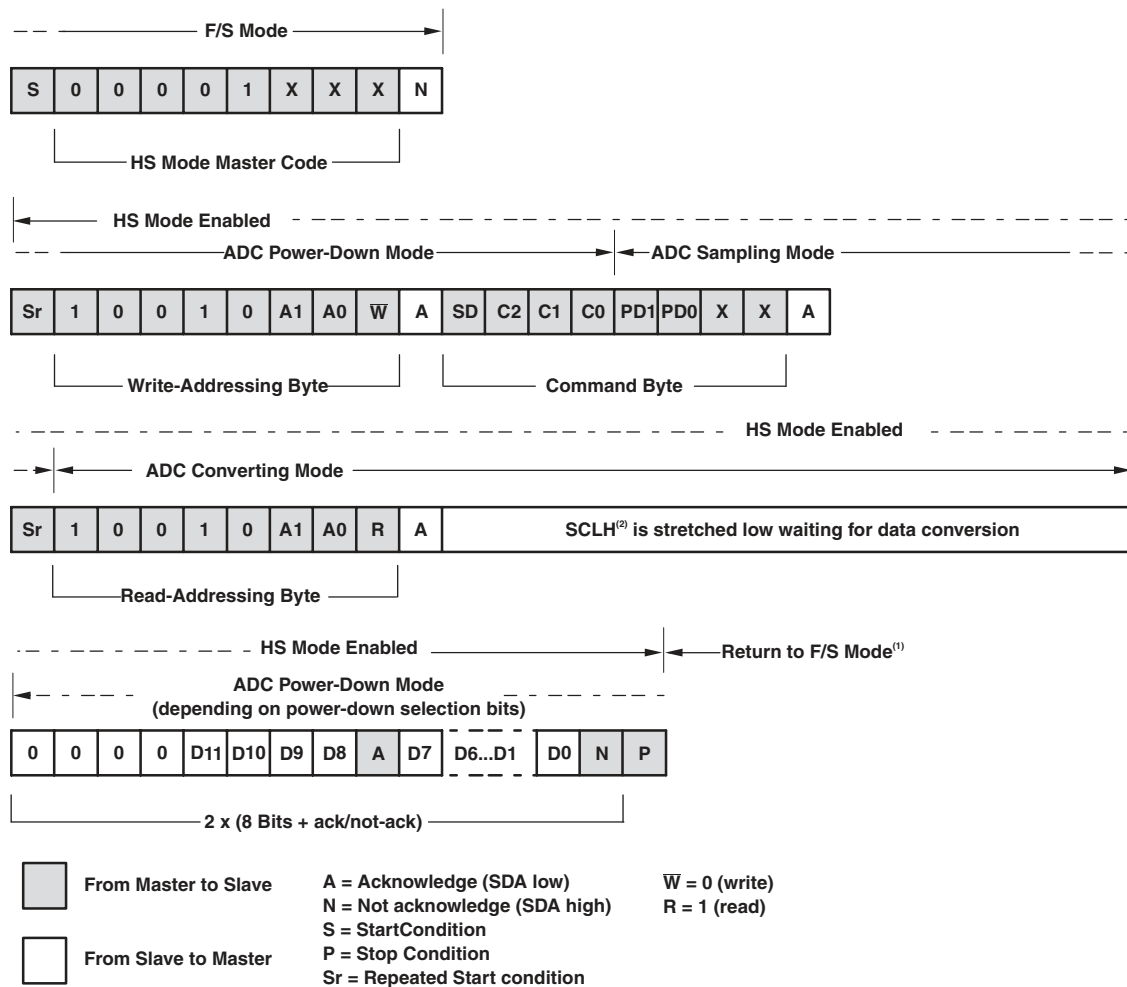

NOTES: (1) To remain in HS mode, use Repeated Start instead of Stop.
 (2) SCLH is SCL in HS mode.

Figure 19. Typical Read Sequence in HS Mode

7.4.7 Reading With Reference On or Off

The internal reference defaults to off when the ADS7828 power is on. To turn the internal reference on or off, see [Table 2](#). If the reference (internal or external) is constantly turned on and off, a proper amount of settling time must be added before a normal conversion cycle can be started. The exact amount of settling time needed varies depending on the configuration.

See [Figure 20](#) for an example of the proper internal reference turn-on sequence before issuing the typical read sequences required for the F/S mode when an internal reference is used.

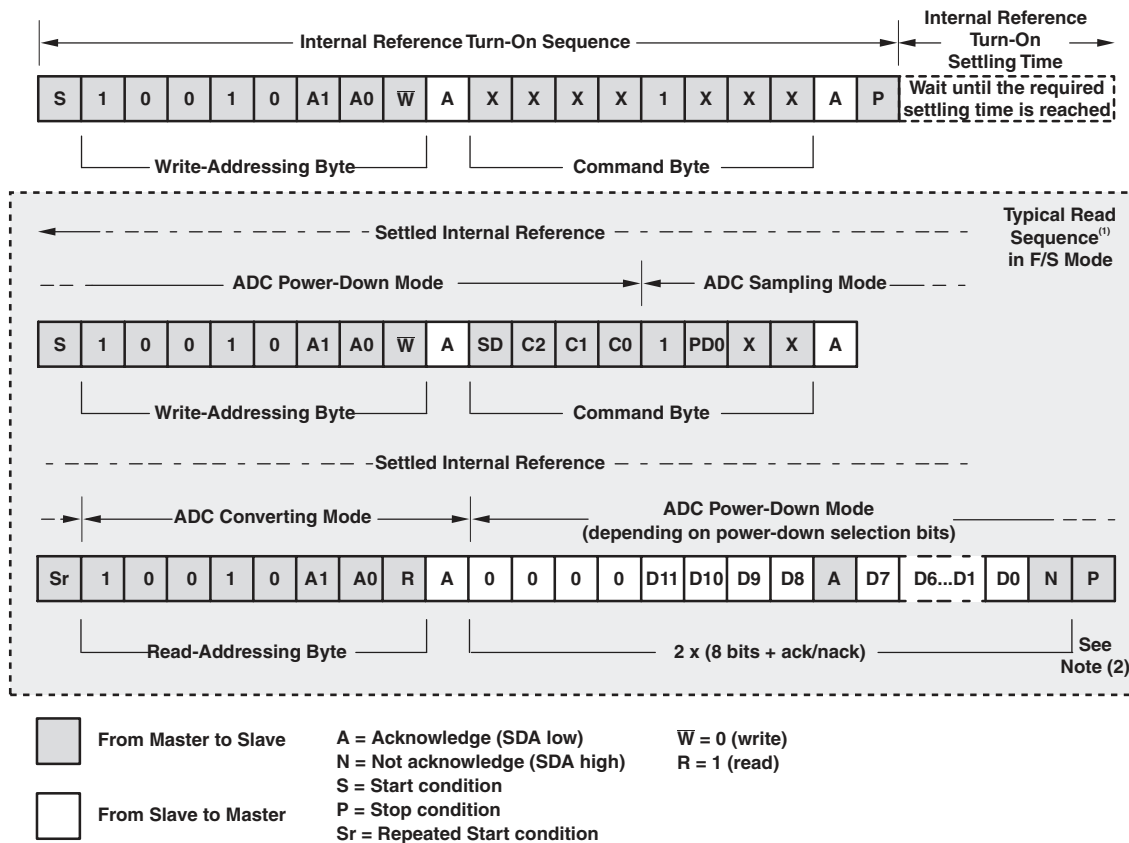

NOTES: (1) Typical read sequences can be reused after the internal reference is settled.
 (2) To secure bus operation and loop back to the stage of write-addressing for next conversion, use Repeated Start.

Figure 20. Internal Reference Turn-On Sequence and Typical Read Sequence (F/S Mode Shown)

When using an internal reference, there are three things that must be done:

1. To use the internal reference, the PD1 bit of Command Byte must always be set to logic 1 for each sample conversion that is issued by the sequence, as shown in [Figure 18](#).
2. To achieve 12-bit accuracy conversion when using the internal reference, the internal reference settling time must be considered, as shown in the Internal VREF vs Turn-On Time Typical Characteristic plot. If the PD1 bit has been set to logic 0 while using the ADS7828, then the settling time must be reconsidered after PD1 is set to logic 1. In other words, whenever the internal reference is turned on after it has been turned off, the settling time must be long enough to get 12-bit accuracy conversion.
3. When the internal reference is off, it is not turned on until both the first Command Byte with PD1 = 1 is sent and then a Stop condition or repeated Start condition is issued. (The actual turn-on time occurs once the Stop or repeated Start condition is issued.) Any Command Byte with PD1 = 1 issued after the internal reference is turned on serves only to keep the internal reference on. Otherwise, the internal reference would be turned off by any Command Byte with PD1 = 0.

The example in [Figure 20](#) can be generalized for an HS mode conversion cycle by changing the timing of the conversion cycle. If using an external reference, PD1 must be set to 0, and the external reference must be settled. The typical sequence in [Figure 18](#) or [Figure 19](#) can then be used.

8 Application and Implementation

NOTE

Information in the following applications sections is not part of the TI component specification, and TI does not warrant its accuracy or completeness. TI's customers are responsible for determining suitability of components for their purposes. Customers should validate and test their design implementation to confirm system functionality.

8.1 Application Information

The following sections give example circuits and suggestions for using the ADS7828-Q1 device in various situations.

8.1.1 Basic Connections

For many applications, connecting the ADS7828-Q1 device is simple. [Figure 21](#) shows a basic connection diagram for the ADS7828-Q1 device.

The fully differential voltage input of the ADS7828-Q1 device is ideal for connection to differential sources with moderately low source impedance, such as thermocouples and thermistors. Although the ADS7828-Q1 device can read bipolar differential signals, they cannot accept negative voltages on either input. It may be helpful to think of the ADS7828-Q1 positive voltage input as *noninverting*, and of the negative input as *inverting*.

When the ADS7828-Q1 device converts data, it draws current in short spikes. The 0.1- μ F bypass capacitor supplies the momentary bursts of extra current needed from the supply.

The ADS7828-Q1 device interfaces directly to standard mode, fast mode, and high-speed mode I²C controllers. Any microcontroller I²C peripheral, including master-only and non-multiple-master I²C peripherals, can operate with the ADS7828-Q1 device. The ADS7828-Q1 device does not perform clock-stretching (that is, it never pulls the clock line low), so it is not necessary to provide for this function unless other clock-stretching devices are on the same I²C bus.

Pullup resistors are required on both the SDA and SCL lines because I²C bus drivers are open-drain. The size of these resistors depends on the bus operating speed and capacitance of the bus lines. Higher-value resistors consume less power, but increase the transition times on the bus, limiting the bus speed. Lower-value resistors allow higher speed at the expense of higher power consumption. Long bus lines have higher capacitance and require smaller pullup resistors to compensate. The resistors should not be too small; if they are, the bus drivers may not be able to pull the bus lines low.

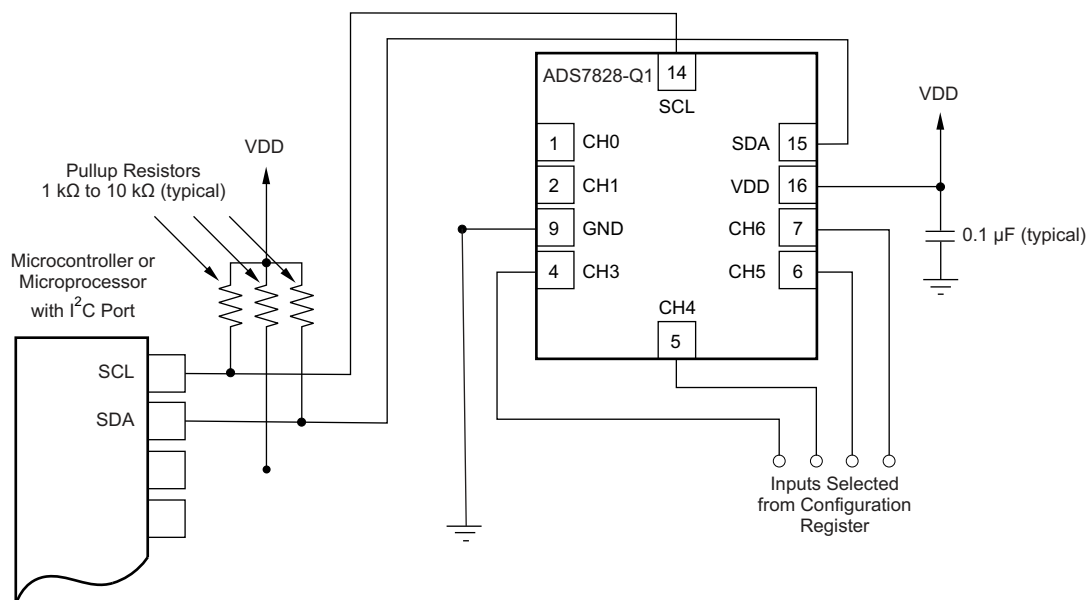
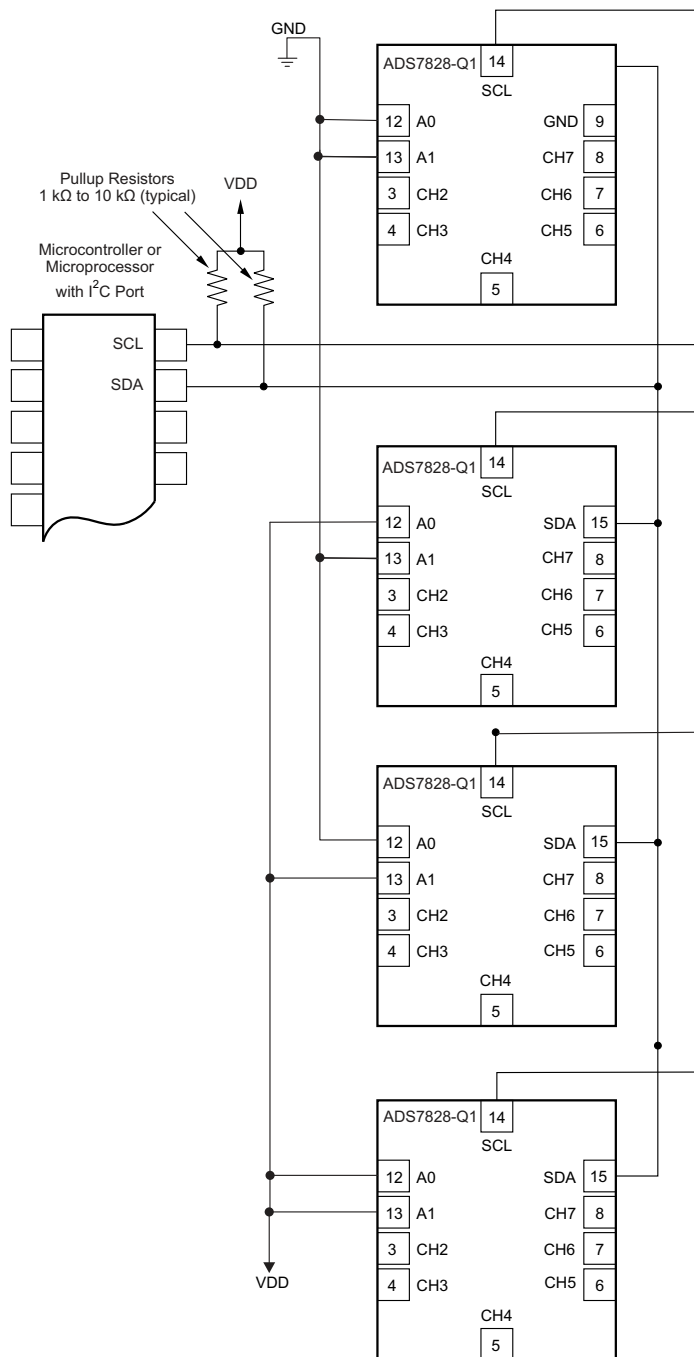

Figure 21. Typical Connections of the ADS7828-Q1

8.1.1.1 Connecting Multiple Devices

Connecting multiple ADS7828-Q1 devices to a single bus is simple. Using the address pin, the ADS7828-Q1 device can be set to one of four different I²C addresses. Figure 22 shows an example using three ADS7828-Q1 devices. Up to four ADS7828-Q1 devices (using different address pin configurations) can be connected to a single bus.

Only one set of pullup resistors is require per bus. The pullup resistor values can be lowered slightly to compensate for the additional bus capacitance presented by multiple devices and increased line length.



The ADS7828-Q1 power and input connections are omitted for clarity. The ADDR pin selects the I²C address.

Figure 22. Connecting Multiple ADS7828-Q1 Devices

8.1.1.2 Using GPIO Ports for Communication

Most microcontrollers have programmable input-output (I/O) pins that can be set in software to act as inputs or outputs. If an I²C controller is not available, the ADS7828-Q1 device can be connected to GPIO pins and the I²C bus protocol simulated, or *bit-banged*, in software. Figure 23 shows an example of this configuration for a single ADS7828-Q1 device.

Bit-banging the I²C with GPIO pins occurs by setting the GPIO line to 0 and toggling it between input and output modes to apply the proper bus states. To drive the line low, the pin is set to output 0; to let the line go high, the pin is set to input. When the pin is set to input, the state of the pin can be read; if another device is pulling the line low, this configuration reads as a 0 in the port input register.

Note that no pullup resistor is shown on the SCL line. In this simple case, the resistor is not needed; the microcontroller can simply leave the line on output, and set it to 1 or 0 as appropriate. This action is possible because the ADS7828-Q1 never drives the clock line low. This technique can also be used with multiple devices, and has the advantage of lower current consumption as a result of the absence of a resistive pullup.

If there are any devices on the bus that may drive the clock lines low, this method should not be used; the SCL line should be high-Z or 0 and a pullup resistor provided as usual.

Some microcontrollers have selectable strong pullup circuits built into the GPIO ports. In some cases, these circuits can be switched on and used in place of an external pullup resistor. Weak pullups are also provided on some microcontrollers, but usually these are too weak for I²C communication. If there is any doubt about the matter, test the circuit before committing it to production.

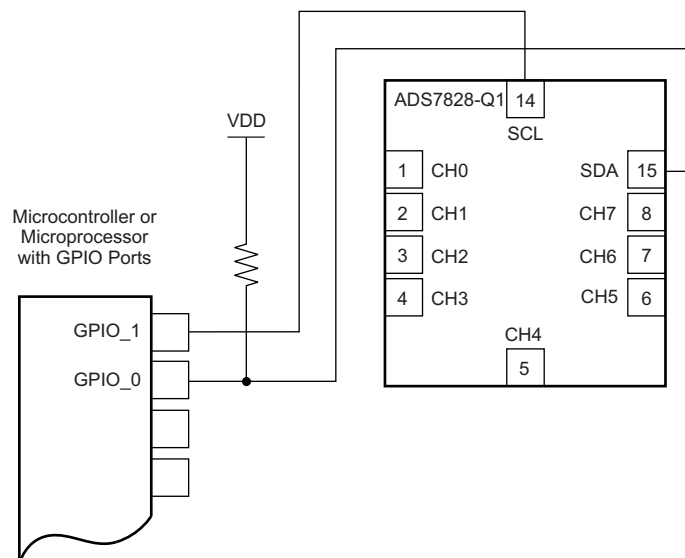

ADS7828-Q1 power and input connections omitted for clarity.

Figure 23. Using GPIO with a Single ADS7828-Q1

8.1.1.3 Single-Ended Inputs

Although the ADS7828-Q1 device has four differential inputs, the device can easily measure eight single-ended signals. Figure 24 shows a single-ended connection scheme. The ADS7828-Q1 device is configured for single-ended measurement by configuring the MUX to measure each channel with respect to ground. Data are then read out of one input based on the selection on the configuration register. The single-ended signal can range from 0 V to the supply voltage. The ADS7828-Q1 device loses no linearity anywhere within the input range. Negative voltages cannot be applied to this circuit because the ADS7828-Q1 device can only accept positive voltages.

The ADS7828-Q1 input range is bipolar differential with respect to the reference. The single-ended circuit shown in Figure 24 covers only half the ADS7828-Q1 input scale because it does not produce differentially negative inputs; therefore, one bit of resolution is lost.

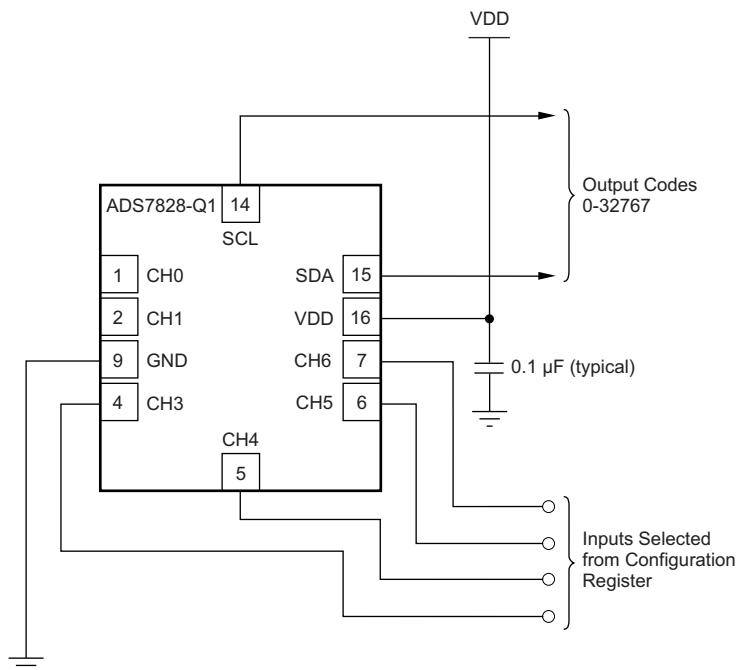

Digital and address pin connections omitted for clarity.

Figure 24. Measuring Single-Ended Inputs

8.2 Typical Applications

8.2.1 ADS7828-Q1 With Current Shunt Monitor

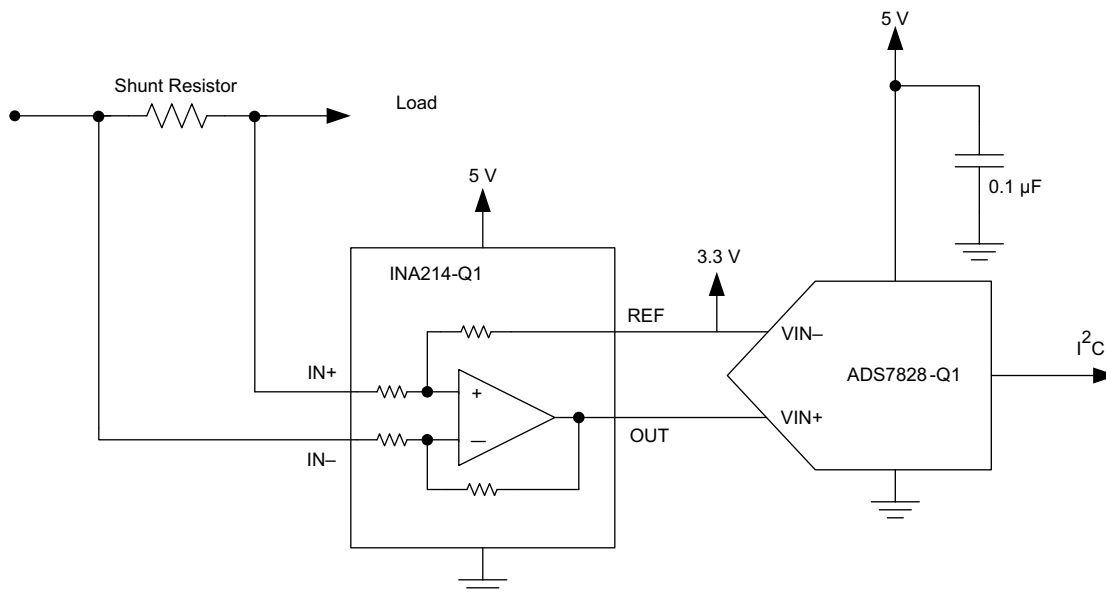

Figure 25. ADS7828-Q1 With Current Shunt Monitor

Typical Applications (continued)

8.2.1.1 Design Requirements

For this design example, the ADS7828-Q1 device is paired with a current shunt monitor. Bi-directional current monitoring is required when there is both charging and discharging. The requirements for this example are as follows:

- Voltage across current shunt varies –15 mV to 15 mV
- 5-V supply
- 3.3-V rail available as reference

8.2.1.2 Detailed Design Procedure

8.2.1.2.1 Part Selection

The INA214-Q1 device was selected because of the low offset and zero drift of the device. The ADS7828-Q1 device has a low noise floor, so it can support more of the gain. For this reason, the lowest gain option was selected from the INA21x-Q1 family. The INA214-Q1 device has a gain of 50.

8.2.1.2.2 Full-Scale Differential Range

First, determine the full-scale differential range into the ADS7828-Q1 device.

$$V_{fs} = V_{IN_{diff}} \times G_{INA214} \quad (1)$$

$$V_{fs} = \pm 15\text{mV} \times 100 \quad (2)$$

$$V_{fs} = \pm 1.5\text{V} \quad (3)$$

8.2.1.2.3 Circuit Implementation

Because the ADS7828-Q1 device has a differential input, connect the reference voltage of the INA214-Q1 device to the negative input terminal of the ADS7828-Q1 device. Because bi-directional current sensing is required in this application, VREF must be chosen so that:

$$V_{REF} > \frac{V_{fs}}{2} \quad (4)$$

$$V_{REF} < V_{supply} - \frac{V_{fs}}{2}$$

where

- $V_{fs} = 3\text{V}$ (5)

A 3.3-V reference is used for this example. Because the ADS7828-Q1 device is a differential input ADC, a resistive divider can be used to generate the reference voltage because impedance effects on the INA214-Q1 device is canceled out by the ADS7828-Q1 device.

8.2.1.3 Application Curve

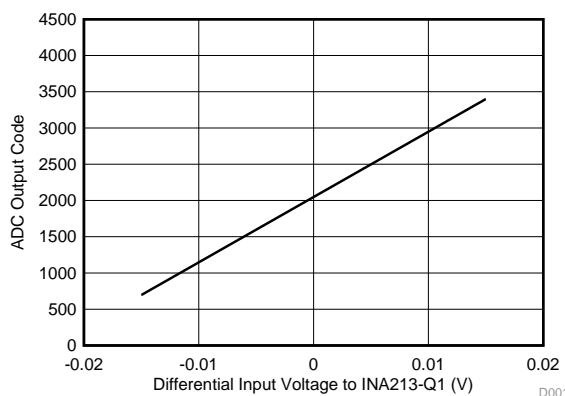

Figure 26. ADC Code vs Voltage Across Current-Shunt Resistor in Bi-Directional Current Sensing Application

9 Power Supply Recommendations

The device requires only one power supply, VDD, which can have an input voltage between 2.7 V and 5.0 V. The value of VDD affects the input voltage range and the digital logic high and low levels. A decoupling capacitor should be placed close to the VDD pin. TI recommends a value of at least 0.1 μ F.

10 Layout

10.1 Layout Guidelines

For optimum performance, care should be taken with the physical layout of the ADS7828 circuitry. The basic SAR architecture is sensitive to glitches or sudden changes on the power supply, reference, ground connections, and digital inputs that occur just prior to latching the output of the analog comparator. Therefore, during any single conversion for an "n-bit" SAR converter, there are n "windows" in which large external transient voltages can easily affect the conversion result. Such glitches might originate from switching power supplies, nearby digital logic, and high-power devices.

With this in mind, power to the ADS7828 should be clean and well-bypassed. A 0.1- μ F ceramic bypass capacitor should be placed as close to the device as possible. A 1- μ F to 10- μ F capacitor may also be needed if the impedance of the connection between +V_{DD} and the power supply is high.

The ADS7828 architecture offers no inherent rejection of noise or voltage variation in regards to using an external reference input. This is of particular concern when the reference input is tied to the power supply. Any noise and ripple from the supply will appear directly in the digital results. While high-frequency noise can be filtered out, voltage variation due to line frequency (50 Hz or 60 Hz) can be difficult to remove.

The GND pin should be connected to a clean ground point. In many cases, this will be the "analog" ground. Avoid connections that are too near the grounding point of a microcontroller or digital signal processor. The ideal layout will include an analog ground plane dedicated to the converter and associated analog circuitry.

10.2 Layout Example

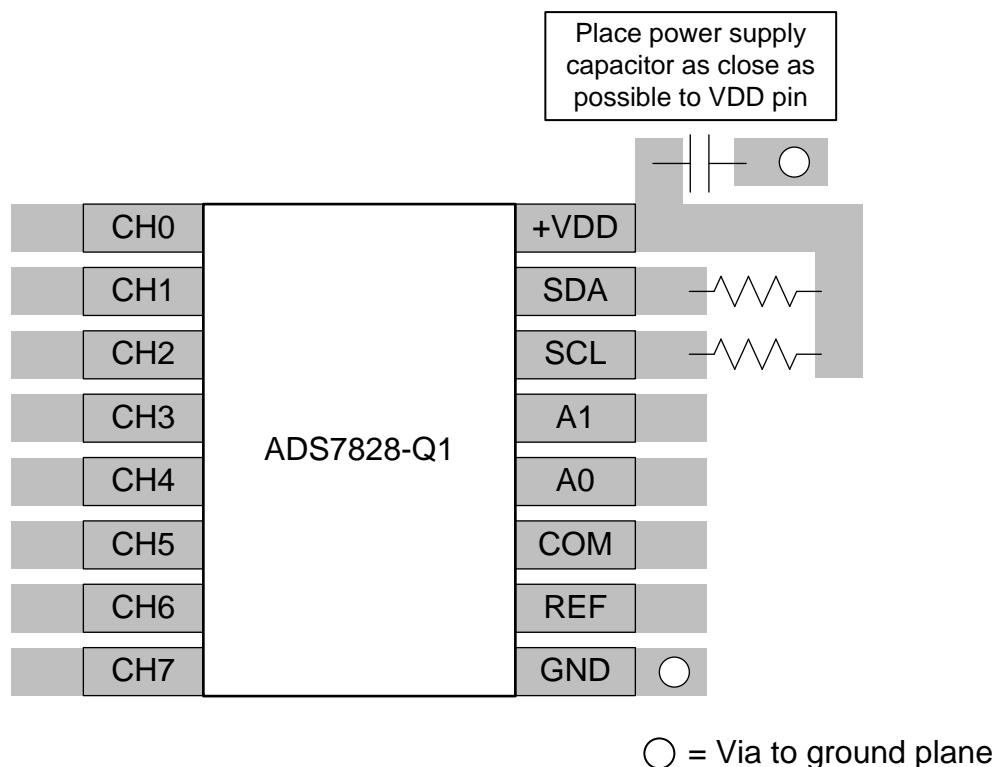

Figure 27. Layout Example

11 Device and Documentation Support

11.1 Documentation Support

11.1.1 Related Documentation

For related documentation see the following:

- *ADS7823—20 EVM*, [SLAU124](#)
- *Determining Minimum Acquisition Times for SAR ADCs When a Step Function is Applied to the Input*, [SBAA173](#)
- *Determining Minimum Acquisition Times for SAR ADCs When a DC Voltage is Applied to the Input*, [SBAA178](#)

11.2 Community Resources

The following links connect to TI community resources. Linked contents are provided "AS IS" by the respective contributors. They do not constitute TI specifications and do not necessarily reflect TI's views; see TI's [Terms of Use](#).

TI E2E™ Online Community *TI's Engineer-to-Engineer (E2E) Community*. Created to foster collaboration among engineers. At e2e.ti.com, you can ask questions, share knowledge, explore ideas and help solve problems with fellow engineers.

Design Support *TI's Design Support* Quickly find helpful E2E forums along with design support tools and contact information for technical support.

11.3 Trademarks

E2E is a trademark of Texas Instruments.
All other trademarks are the property of their respective owners.

11.4 Electrostatic Discharge Caution



These devices have limited built-in ESD protection. The leads should be shorted together or the device placed in conductive foam during storage or handling to prevent electrostatic damage to the MOS gates.

11.5 Glossary

[SLYZ022](#) — *TI Glossary*.

This glossary lists and explains terms, acronyms, and definitions.

12 Mechanical, Packaging, and Orderable Information

The following pages include mechanical, packaging, and orderable information. This information is the most current data available for the designated devices. This data is subject to change without notice and revision of this document. For browser-based versions of this data sheet, refer to the left-hand navigation.

PACKAGING INFORMATION

Orderable Device	Status (1)	Package Type	Package Drawing	Pins	Package Qty	Eco Plan (2)	Lead finish/ Ball material (6)	MSL Peak Temp (3)	Op Temp (°C)	Device Marking (4/5)	Samples
ADS7828EIPWRQ1	ACTIVE	TSSOP	PW	16	2500	RoHS & Green	NIPDAU	Level-2-260C-1 YEAR	-40 to 85	ADS 7828EI	Samples

(1) The marketing status values are defined as follows:

ACTIVE: Product device recommended for new designs.

LIFEBUY: TI has announced that the device will be discontinued, and a lifetime-buy period is in effect.

NRND: Not recommended for new designs. Device is in production to support existing customers, but TI does not recommend using this part in a new design.

PREVIEW: Device has been announced but is not in production. Samples may or may not be available.

OBSOLETE: TI has discontinued the production of the device.

(2) **RoHS:** TI defines "RoHS" to mean semiconductor products that are compliant with the current EU RoHS requirements for all 10 RoHS substances, including the requirement that RoHS substance do not exceed 0.1% by weight in homogeneous materials. Where designed to be soldered at high temperatures, "RoHS" products are suitable for use in specified lead-free processes. TI may reference these types of products as "Pb-Free".

RoHS Exempt: TI defines "RoHS Exempt" to mean products that contain lead but are compliant with EU RoHS pursuant to a specific EU RoHS exemption.

Green: TI defines "Green" to mean the content of Chlorine (Cl) and Bromine (Br) based flame retardants meet JS709B low halogen requirements of <=100ppm threshold. Antimony trioxide based flame retardants must also meet the <=1000ppm threshold requirement.

(3) MSL, Peak Temp. - The Moisture Sensitivity Level rating according to the JEDEC industry standard classifications, and peak solder temperature.

(4) There may be additional marking, which relates to the logo, the lot trace code information, or the environmental category on the device.

(5) Multiple Device Markings will be inside parentheses. Only one Device Marking contained in parentheses and separated by a "~" will appear on a device. If a line is indented then it is a continuation of the previous line and the two combined represent the entire Device Marking for that device.

(6) Lead finish/Ball material - Orderable Devices may have multiple material finish options. Finish options are separated by a vertical ruled line. Lead finish/Ball material values may wrap to two lines if the finish value exceeds the maximum column width.

Important Information and Disclaimer:The information provided on this page represents TI's knowledge and belief as of the date that it is provided. TI bases its knowledge and belief on information provided by third parties, and makes no representation or warranty as to the accuracy of such information. Efforts are underway to better integrate information from third parties. TI has taken and continues to take reasonable steps to provide representative and accurate information but may not have conducted destructive testing or chemical analysis on incoming materials and chemicals. TI and TI suppliers consider certain information to be proprietary, and thus CAS numbers and other limited information may not be available for release.

In no event shall TI's liability arising out of such information exceed the total purchase price of the TI part(s) at issue in this document sold by TI to Customer on an annual basis.

OTHER QUALIFIED VERSIONS OF ADS7828-Q1 :

- Catalog: [ADS7828](#)

NOTE: Qualified Version Definitions:

- Catalog - TI's standard catalog product

TAPE AND REEL INFORMATION

QUADRANT ASSIGNMENTS FOR PIN 1 ORIENTATION IN TAPE

*All dimensions are nominal

Device	Package Type	Package Drawing	Pins	SPQ	Reel Diameter (mm)	Reel Width W1 (mm)	A0 (mm)	B0 (mm)	K0 (mm)	P1 (mm)	W (mm)	Pin1 Quadrant
ADS7828EIPWRQ1	TSSOP	PW	16	2500	330.0	12.4	6.9	5.6	1.6	8.0	12.0	Q1

TAPE AND REEL BOX DIMENSIONS

*All dimensions are nominal

Device	Package Type	Package Drawing	Pins	SPQ	Length (mm)	Width (mm)	Height (mm)
ADS7828EIPWRQ1	TSSOP	PW	16	2500	367.0	367.0	35.0

PW0016A



PACKAGE OUTLINE

TSSOP - 1.2 mm max height

SMALL OUTLINE PACKAGE



4220204/A 02/2017

NOTES:

1. All linear dimensions are in millimeters. Any dimensions in parenthesis are for reference only. Dimensioning and tolerancing per ASME Y14.5M.
2. This drawing is subject to change without notice.
3. This dimension does not include mold flash, protrusions, or gate burrs. Mold flash, protrusions, or gate burrs shall not exceed 0.15 mm per side.
4. This dimension does not include interlead flash. Interlead flash shall not exceed 0.25 mm per side.
5. Reference JEDEC registration MO-153.

EXAMPLE BOARD LAYOUT

PW0016A

TSSOP - 1.2 mm max height

SMALL OUTLINE PACKAGE



LAND PATTERN EXAMPLE
EXPOSED METAL SHOWN
SCALE: 10X



SOLDER MASK DETAILS

4220204/A 02/2017

NOTES: (continued)

- 6. Publication IPC-7351 may have alternate designs.
- 7. Solder mask tolerances between and around signal pads can vary based on board fabrication site.

EXAMPLE STENCIL DESIGN

PW0016A

TSSOP - 1.2 mm max height

SMALL OUTLINE PACKAGE



SOLDER PASTE EXAMPLE
BASED ON 0.125 mm THICK STENCIL
SCALE: 10X

4220204/A 02/2017

NOTES: (continued)

8. Laser cutting apertures with trapezoidal walls and rounded corners may offer better paste release. IPC-7525 may have alternate design recommendations.
9. Board assembly site may have different recommendations for stencil design.

IMPORTANT NOTICE AND DISCLAIMER

TI PROVIDES TECHNICAL AND RELIABILITY DATA (INCLUDING DATA SHEETS), DESIGN RESOURCES (INCLUDING REFERENCE DESIGNS), APPLICATION OR OTHER DESIGN ADVICE, WEB TOOLS, SAFETY INFORMATION, AND OTHER RESOURCES "AS IS" AND WITH ALL FAULTS, AND DISCLAIMS ALL WARRANTIES, EXPRESS AND IMPLIED, INCLUDING WITHOUT LIMITATION ANY IMPLIED WARRANTIES OF MERCHANTABILITY, FITNESS FOR A PARTICULAR PURPOSE OR NON-INFRINGEMENT OF THIRD PARTY INTELLECTUAL PROPERTY RIGHTS.

These resources are intended for skilled developers designing with TI products. You are solely responsible for (1) selecting the appropriate TI products for your application, (2) designing, validating and testing your application, and (3) ensuring your application meets applicable standards, and any other safety, security, regulatory or other requirements.

These resources are subject to change without notice. TI grants you permission to use these resources only for development of an application that uses the TI products described in the resource. Other reproduction and display of these resources is prohibited. No license is granted to any other TI intellectual property right or to any third party intellectual property right. TI disclaims responsibility for, and you will fully indemnify TI and its representatives against, any claims, damages, costs, losses, and liabilities arising out of your use of these resources.

TI's products are provided subject to [TI's Terms of Sale](#) or other applicable terms available either on ti.com or provided in conjunction with such TI products. TI's provision of these resources does not expand or otherwise alter TI's applicable warranties or warranty disclaimers for TI products.

TI objects to and rejects any additional or different terms you may have proposed.

Mailing Address: Texas Instruments, Post Office Box 655303, Dallas, Texas 75265
Copyright © 2022, Texas Instruments Incorporated