

FEATURES

- Single-channel isolated signal-conditioning modules.
- Accepts outputs from Thermocouple, millivolt, volt and current signals.
- Complete microcomputer-based data acquisition systems.
- Can be remotely reconfigured for various sensor types and input ranges.

APPLICATIONS

- Process Monitoring & Control
- Test Stand Automation
- Machine Monitoring
- Material Testing
- Remote Energy Mangement
- Laboratory Data Acquisition

PRODUCT OVERVIEW

The 6B Series delivers sensor-to-host signal-conditioning for remote applications. Software-configurable for a wide variety of sensor types, including: analog input, analog output, and digital I/O, the 6B Series is intended for remote data acquisition, machine monitoring, remote energy management and process monitoring and control applications.

Including transformer-based isolation, ranging, linearization, A/d conversion and RS-232C/RS-485 serial communication for up to 256 channels per serial port, the 6B Series modules and boards are a complete, low-cost interface between computers and analog signals.

All 6B Series input/output modules are fully encapsulated and identical in pin-out and size, facilitating their ability to be mixed and matched with all other 6B Series modules on the same backplane. The 6B Series is fully rated over the industrial temperature range of -25°C to +85°C.

Each 6B Series module and board is a complete microcontroller-based process monitoring and control system, with all calibration, address and linearizing parameters stored in non-volatile memory. Being microcontroller-based, 6b Series modules can be configured for various sensor types, including RTD and thermocouple, and a wide variety of input ranges. This reduces the number of different modules that need to be used

Rev. 0

Information furnished by Analog Devices is believed to be accurate and reliable. However, no responsibility is assumed by Analog Devices for its use, nor for any infringements of patents or other rights of third parties that may result from its use. Specifications subject to change without notice. No license is granted by implication or otherwise under any patent or patent rights of Analog Devices. Trademarks and registered trademarks are the property of their respective companies.

in a given application and carried in inventory.

FUNCTIONAL BLOCK DIAGRAM

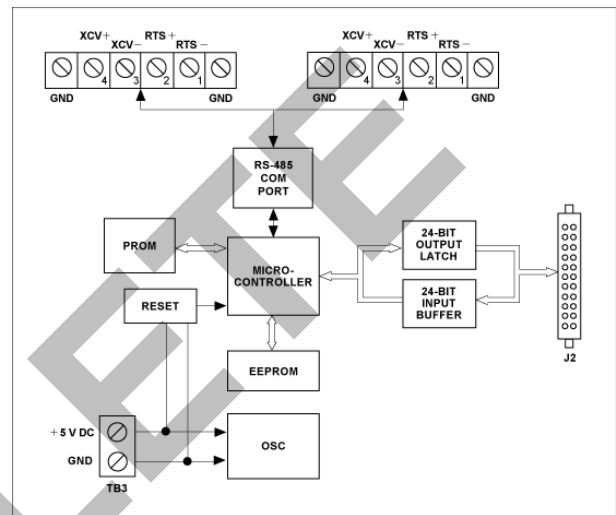

Figure 1. 6B50-1 & 6B50-2 Functional Block Diagram

Designed for industrial applications, the 6B Series modules incorporate transformer-based isolation with surface-mount manufacturing technology – providing increased reliability at low cost. The compact, rugged 6B Series analog modules can be mixed and matched on a 16-channel backplane for high density, remote process monitoring and control.

Communications between backplanes, modules and host is in ASCII over an RS-232C link or RS-485 bi-directional serial bus. Circuitry to convert RS-232C to RS485 is built into the 6B backplane. Baud rates are software programmable, with speeds up to 19.2 K Baud.

The 6B Series digital subsystem communication is compatible with the overall 6B Series communication protocol. Each digital I/O board can be configured for its address, baud rate and checksum status. Connection to the 16 and 24-channel solid state relay backplanes is by a 50-conductor ribbon cable. This enables interfacing with input and outputs from 4 V to 240 V. Power control modules are also available that can switch up to 3A and come with a variety of ratings for low voltage DC up to 280 VAC.

GENERAL DESCRIPTION

The 6B50-1 and 6B50-2 are 24-channel digital I/O boards which are compatible with the 6B Series Signal-Conditioning Modules at the network level. Each converts commands from the host computer into logic levels suitable for interfacing with industry-standard opto-isolated digital I/O panels. All I/O channels can be configured for input or output, using bit or byte addressing. In addition, the status of the port can be read back by the host to confirm the I/O configuration.

Synchronized Sampling – The synchronized sampling command allows data to be sampled simultaneously from all 6B11, 6B11HV, 6B12, 6B12HV modules and all 6B50 boards in a 6B Series system. Each module or board stores the data in a separate register within its microcontroller and can access the data with a separate command.

Software Configuration – The 6B50-1 and 6B50-2 can be

software-configured for address, baud rate, data format, checksum status and I/O configuration. All programmable parameters are stored in the nonvolatile memory of each digital I/O board.

An on-board microcontroller communicates with the host through an RS-232C port (Model 6B50-2 or with a 6B Series backplane through an RS 485 port (Model 6B50-1) to exchange command and status information.

An included EEPROM stores system parameters (address, baud rate, checksum, etc.) as well as I/O configuration information. The microcontroller is interfaced to 8-bit latches and buffers a maximum of 24 digital i/o channels. Each channel can be individually set as either an input or output. The 6B50-1 and 6B50-2 are 3.47-inch x 6.5-inch open boards that can be panel or rack mounted.

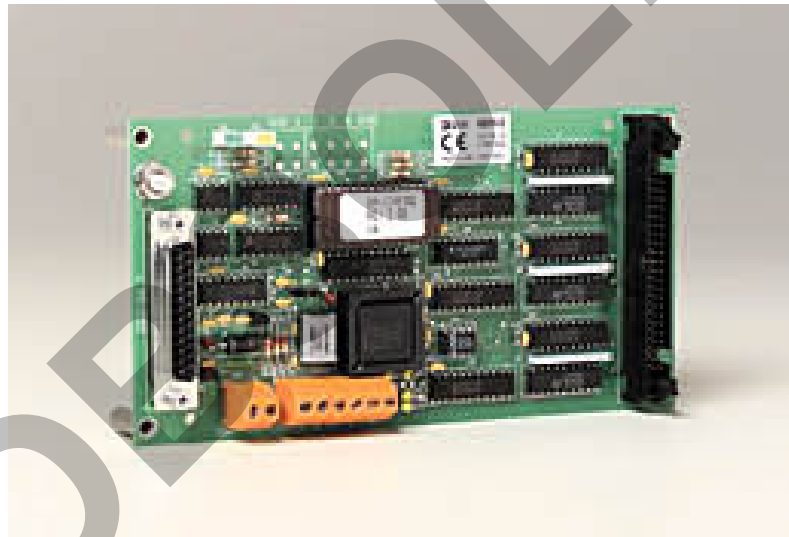

Figure 2

6B50-1 AND 6B50-2 Models Available

Model	Host PC Communications	Expansion & Module Communications	Digital I/O (Software Configurable)
6B50-1	N/A	RS-485	24 Channels
6B50-2	RS-232C	RS-485	24 Channels

6B50-1 and 6B50-2 Specifications
(typical @ +23°C ±5°C and V_s = +24 V dc)

Description	Model 6B50-1 and 6B50-2
Digital I/O	
Number of I/O Channels	24 (Software Configurable for Input or Output)
I/O Circuit Configuration	Open Collector Outputs with 47 kΩ Pullups to +5 V
Digital Inputs	
High-Level Input	+3.5 V minimum; +5.25 V maximum
Low Level Output	0.8 V maximum
Digital Outputs	
High Level Output Current	50 μA @ +5 V
Low Level Output Current	100 mA @ +1.1 V
High-Level Output Voltage	+5.25 V maximum
Connector	Male, 50-Pin
Communications	
Model 6B50-2	
Protocol	RS-232C
Baud Rates, Software Selectable	300K, 600K, 1.2K, 2.4K, 4.8K, 9.6K, 19.2K
Distance From Host PC and 6B50-2	50 feet maximum
Connector	Male, DB-25
LED Indicators	Data and Enable
Synchronized Sampling Command	Yes
Conversion Time	1 ms maximum
Model 6B50-1	
Protocol	RS-485
Baud Rates, Software Selectable	300K, 600K, 1.2K, 2.4K, 4.8K, 9.6K, 19.2K
Distance From 6B Backplane and 6B50-1	4000 feet maximum
Connector	6 Screw Terminals
LED Indicators	Data and Enable
Synchronized Sampling Command	Yes
Conversion Time	1 ms maximum

Voltage, Operating	+5 V dc \pm 5%
Voltage, maximum safe limit	+6.5 V dc
Current	+70 mA ¹
Fuse	1.5 amp Slow-blow, Littelfuse™ Type 251.01.5
Mechanical Dimensions	3.47" x 6.5" (90.68 mm x 165.1 mm)
	Environmental
Temperature Range	
Rated Performance	0°C to +70°C
Operating	0°C to +70°C
Storage	-40°C to +85°C
Relative Humidity	0 to 95% @ +60°C, non-condensing

¹ Excluding load current.

Specifications subject to change without notice.

OBSOLETE

PIN CONFIGURATIONS AND FUNCTIONAL DESCRIPTIONS

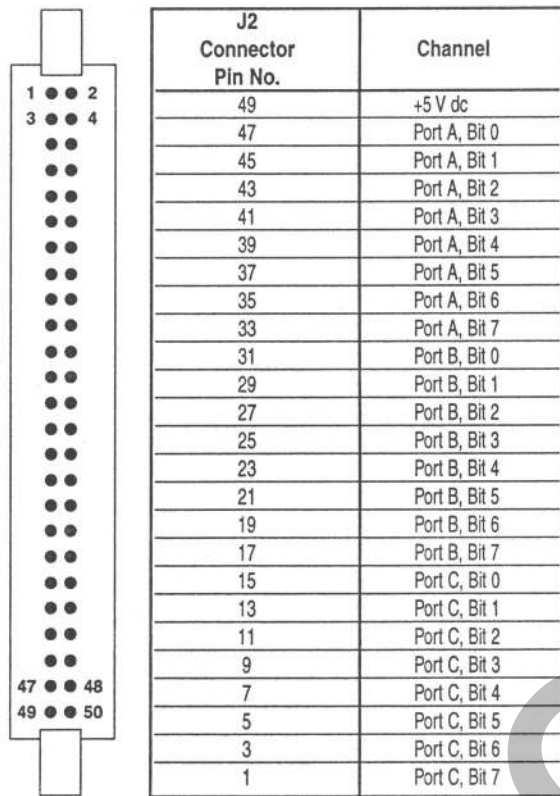

Top View - J2 *Note: All even-numbered connector pins are connected to digital ground.*

Figure 3 . Model 6B50 Series Connector, with pin-out assignment.

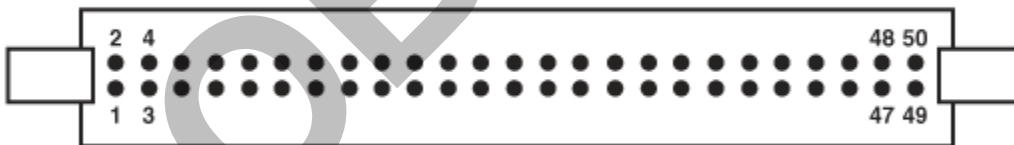

Figure 4 6B50-1 & 6B50-2 Input Field Connections

ESD CAUTION

ESD (electrostatic discharge) sensitive device. Electrostatic charges as high as 4000 V readily accumulate on the human body and test equipment and can discharge without detection. Although this product features proprietary ESD protection circuitry, permanent damage may occur on devices subjected to high energy electrostatic discharges. Therefore, proper ESD precautions are recommended to avoid performance degradation or loss of functionality.



OUTLINE DIMENSIONS

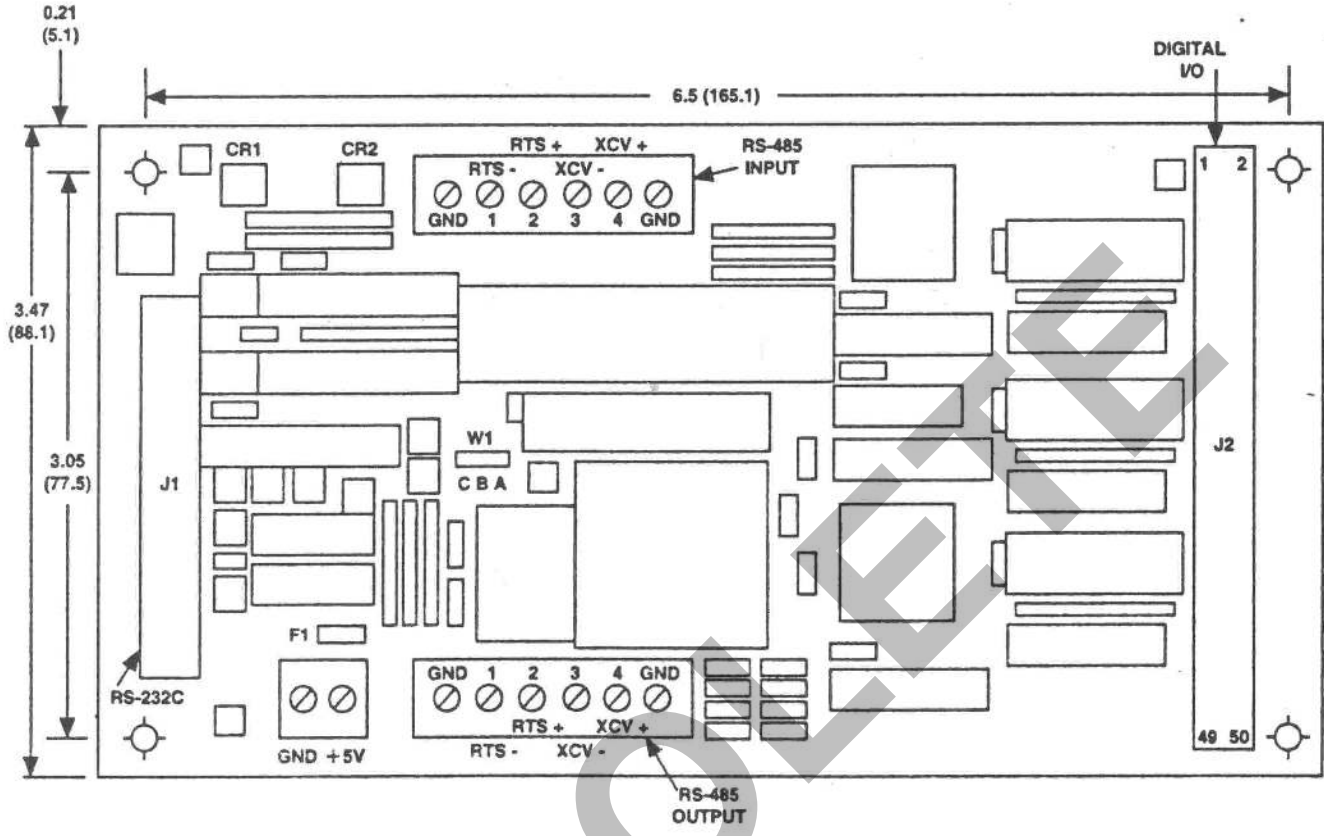

Figure 5. Outline Dimensions

NOTES

OBSOLETE

NOTES

OBSOLETE