

THIS DRAWING IS UNPUBLISHED. RELEASED FOR PUBLICATION  
 © COPYRIGHT BY TYCO ELECTRONICS CORPORATION. ALL INTERNATIONAL RIGHTS RESERVED.

COMPONENT	MATERIAL	FINISH
HOUSING	STAINLESS STEEL PER ASTM-A484 AND ASTM-A582, TYPE 303	GOLD PLATE PER ASTM-B-488 OVER NICKEL PLATE PER AMS-QQ-N-290
COUPLING NUT	STAINLESS STEEL PER ASTM-A484 AND ASTM-A582, TYPE 303	PASSIVATE PER SAE-AMS-2700
DIELECTRIC	TFE FLUOROCARBON PER ASTM-D-1457	N/A
CENTER CONTACT	BERYLLIUM COPPER PER ASTM B 196, ALLOY C17300, CONDITION H	GOLD PLATE PER ASTM-B-488 OVER NICKEL PLATE PER AMS-QQ-N-290
RETAINING RING	BERYLLIUM COPPER PER ASTM B 194, ALLOY C17200, CONDITION H	N/A
GASKET	SILICONE RUBBER PER ZZ-R-765	N/A

DESIGNED FOR USE WITH FA12RX CABLE	
CABLE ENTRY DIAMETER MINIMUM	
CONTACT	.039 [0.99]
HOUSING	.114 [2.90]

LOC	DIST	REVISIONS			
P	LTR	DESCRIPTION	DATE	DWN	APVD
A		REV PER ECO-09-024744	18NOV09	PY	DW

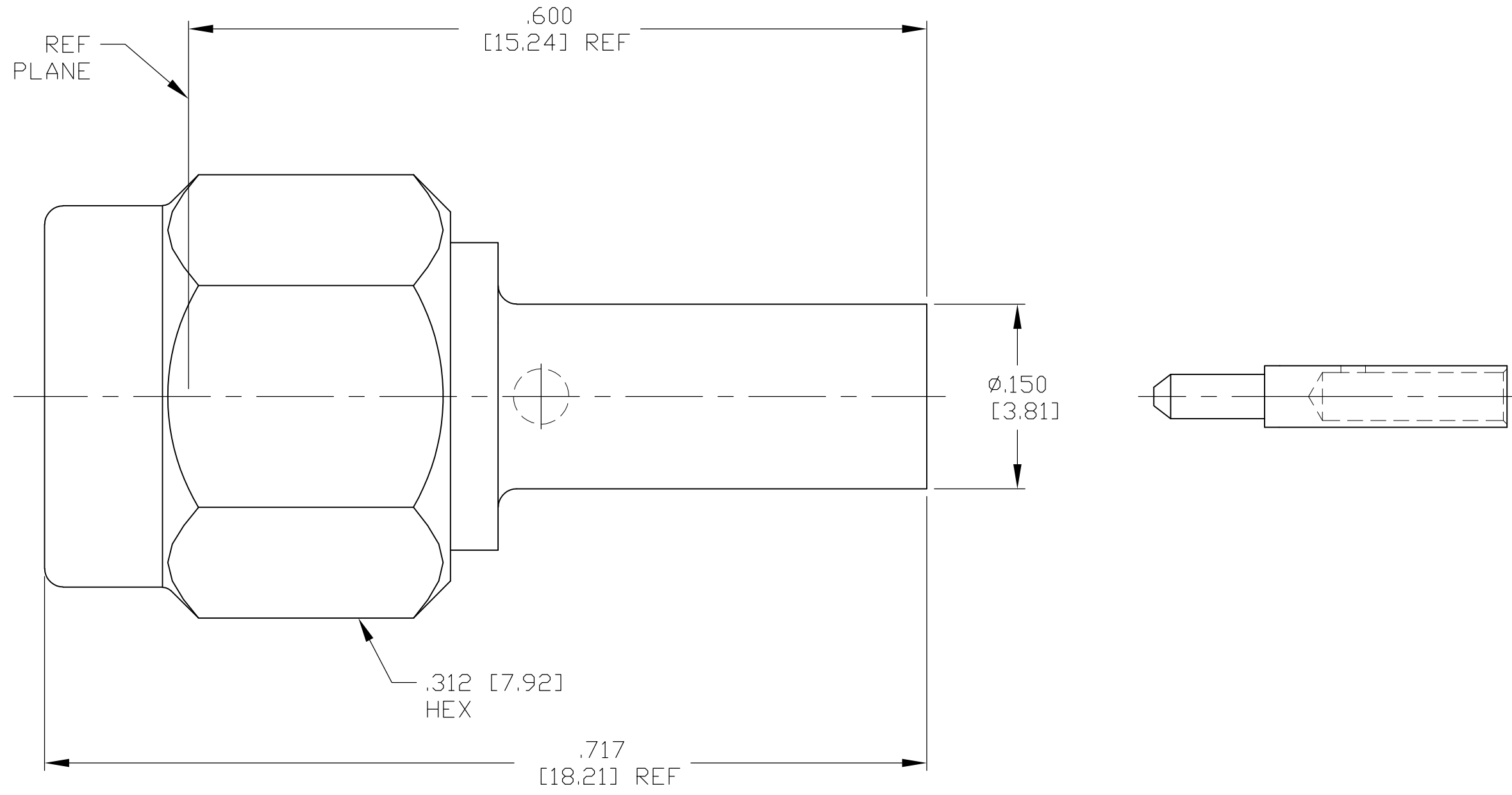

ELECTRICAL	MECHANICAL	ENVIRONMENTAL
Nominal Impedance (Ohms) <u>50</u>	Interface Dimensions MIL-STD-348, Fig. <u>310.1</u>	TEMPERATURE RATING <u>-65°C TO 105°C</u>
Frequency Range (GHz) <u>DC to 18.0</u>	Recommended Mating Torque <u>7 to 10 in-LBs</u>	Vibration MIL-STD-202, Method 204, Condition D
Volt Rating (VRMS MAX) @ Sea Level <u>500</u>	Mating Characteristics: Insertion (MAX Lbs) <u>N/A</u>	Shock MIL-STD-202, Method 213, Condition I
VSWR <u>1.05 + .008f(GHz)</u>	Withdrawal (MIN Oz) <u>N/A</u>	Thermal Shock MIL-STD-202, Method 107, Condition B, EXCEPT HIGH TEMP 115°C
Insertion Loss (dB MAX) <u>.03 √f(GHz)</u>	Force to Engage and Disengage (In/Lbs MAX) <u>2.0</u>	Moisture Resistance MIL-STD-202, Method 106,
RF Leakage (dB MIN) <u>-(90-f(GHz))</u>	Center Contact Captivation: Axial (Lbs) <u>N/A</u>	Corrosion - MIL-STD-202, Method 101, Condition B, 5% salt spray
Corona, 70,000 Ft (VRMS MIN) <u>375</u>	Radial (In/Oz) <u>N/A</u>	
Dielectric Withstanding Voltage (VRMS MIN) @ Sea Level <u>1000</u>	Cable Retention: Axial Force (Lbs) <u>60</u>	
Contact Resistance (Milliohms MAX): Center Contact <u>3.0</u>	Torque (In/Oz) <u>55</u>	
Outer Contact <u>2.0</u>	Weight (Grams) <u>T.B.D.</u>	
Cable to Housing <u>0.5</u>		
RF High Potential @ Sea Level (VRMS MIN @ 5 MHz) <u>1000</u>		
I.R.(Megohms MIN) <u>5,000</u>		

1883239-1  
PART NUMBER

THIS DRAWING IS A CONTROLLED DOCUMENT.		DWN C.C.THOMAS 13FEB2006	Tyco Electronics Corporation Harrisburg, PA 17105-3608	
DIMENSIONS: INCHES		CHK R.GROSS 2-14-06	NAME OSM STRAIGHT CABLE PLUG ASSY, DIRECT SOLDER ATTACHMENT	
TOLERANCES UNLESS OTHERWISE SPECIFIED:		APVD R.GROSS 2-14-06	SIZE A2 CAGE CODE 00779 DRAWING NO C=1883239	
0 PLC ± -	1 PLC ± -	PRODUCT SPEC	RESTRICTED TO	
2 PLC ± -	3 PLC ± .005 [0.13]	APPLICATION SPEC	SCALE 10:1 SHEET 1 of 1 REV A	
4 PLC ± -	ANGLES ± -	WEIGHT -		
MATERIAL SEE TABLE	FINISH SEE TABLE	CUSTOMER DRAWING		