

# Evaluation Board

For AURIX™ TC275

## AURIX™ TC275 lite Kit

Kit Version 1.1

Document Version 1.2

### Board User's Manual

Revision 14. April, 2022

**Edition 14. April, 2022**

**Published by**

**Infineon Technologies AG**

**81726 Munich, Germany**

**© 2022 Infineon Technologies AG**

**All Rights Reserved.**

#### **Legal Disclaimer**

The information given in this document shall in no event be regarded as a guarantee of conditions or characteristics. With respect to any examples or hints given herein, any typical values stated herein and/or any information regarding the application of the device, Infineon Technologies hereby disclaims any and all warranties and liabilities of any kind, including without limitation, warranties of non-infringement of intellectual property rights of any third party.

#### **Information**

For further information on technology, delivery terms and conditions and prices, please contact the nearest Infineon Technologies Office ([www.infineon.com](http://www.infineon.com)).

#### **Warnings**

Due to technical requirements, components may contain dangerous substances. For information on the types in question, please contact the nearest Infineon Technologies Office.

Infineon Technologies components may be used in life-support devices or systems only with the express written approval of Infineon Technologies, if a failure of such components can reasonably be expected to cause the failure of that life-support device or system or to affect the safety or effectiveness of that device or system. Life support devices or systems are intended to be implanted in the human body or to support and/or maintain and sustain and/or protect human life. If they fail, it is reasonable to assume that the health of the user or other persons may be endangered.

---

**Revision History**

Page or Item	Subjects (major changes since previous revision)
Revision 2020, June	Initial released Version is V1.1
Revision 2022, April	Correct Version V1.2
Page 16	Add description of CAN_STB

**Trademarks of Infineon Technologies AG**

AURIX™, C166™, CanPAK™, CIPOS™, CIPURSE™, EconoPACK™, CoolMOS™, CoolSET™, CORECONTROL™, CROSSAVE™, DAVE™, EasyPIM™, EconoBRIDGE™, EconoDUAL™, EconoPIM™, EiceDRIVER™, eupec™, FCOS™, HITFET™, HybridPACK™, I<sup>2</sup>RF™, ISOFACE™, IsoPACK™, MIPAQ™, ModSTACK™, my-d™, NovalithIC™, OptiMOS™, ORIGA™, PRIMARION™, PrimePACK™, PrimeSTACK™, PRO-SIL™, PROFET™, RASIC™, ReverSave™, SatRIC™, SIEGET™, SINDRION™, SIPMOS™, SmartLEWIS™, SOLID FLASH™, TEMPFET™, thinQ!™, TRENCHSTOP™, TriCore™.

**Other Trademarks**

Advance Design System™ (ADS) of Agilent Technologies, AMBA™, ARM™, MULTI-ICE™, KEIL™, PRIMECELL™, REALVIEW™, THUMB™, μVision™ of ARM Limited, UK. AUTOSAR™ is licensed by AUTOSAR development partnership. Bluetooth™ of Bluetooth SIG Inc. CAT-iq™ of DECT Forum. COLOSSUS™, FirstGPS™ of Trimble Navigation Ltd. EMV™ of EMVCo, LLC (Visa Holdings Inc.). EPCOS™ of Epcos AG. FLEXGO™ of Microsoft Corporation. FlexRay™ is licensed by FlexRay Consortium. HYPERTERMINAL™ of Hilgraeve Incorporated. IEC™ of Commission Electrotechnique Internationale. IrDA™ of Infrared Data Association Corporation. ISO™ of INTERNATIONAL ORGANIZATION FOR STANDARDIZATION. MATLAB™ of MathWorks, Inc. MAXIM™ of Maxim Integrated Products, Inc. MICROTEC™, NUCLEUS™ of Mentor Graphics Corporation. Mifare™ of NXP. MIPI™ of MIPI Alliance, Inc. MIPS™ of MIPS Technologies, Inc., USA. muRata™ of MURATA MANUFACTURING CO., MICROWAVE OFFICE™ (MWO) of Applied Wave Research Inc., OmniVision™ of OmniVision Technologies, Inc. Openwave™ Openwave Systems Inc. RED HAT™ Red Hat, Inc. RFMD™ RF Micro Devices, Inc. SIRIUS™ of Sirius Satellite Radio Inc. SOLARIS™ of Sun Microsystems, Inc. SPANSION™ of Spansion LLC Ltd. Symbian™ of Symbian Software Limited. TAIYO YUDEN™ of Taiyo Yuden Co. TEAKLITE™ of CEVA, Inc. TEKTRONIX™ of Tektronix Inc. TOKO™ of TOKO KABUSHIKI KAISHA TA. UNIX™ of X/Open Company Limited. VERILOG™, PALLADIUM™ of Cadence Design Systems, Inc. VLYNQ™ of Texas Instruments Incorporated. VXWORKS™, WIND RIVER™ of WIND RIVER SYSTEMS, INC. ZETEX™ of Diodes Zetex Limited.

Last Trademarks Update 2011-02-24

EtherCAT® is registered trademark and patented technology, licensed by Beckhoff Automation GmbH, Germany.

## Table of Contents

<b>1</b>	<b>Introduction .....</b>	<b>6</b>
1.1	Block Diagram .....	7
<b>2</b>	<b>Hardware Description .....</b>	<b>8</b>
2.1	Power Supply .....	8
<b>3</b>	<b>Pinout of X1 and X2 connectors .....</b>	<b>10</b>
3.1	Shield2Go and MikroBus™ Pinout .....	11
3.2	Solderable Pin Bridges .....	12
3.3	Arduino Compatible Connector .....	12
3.4	User Push Buttons, User LEDs and Potentiometer .....	13
<b>4</b>	<b>Debugging and USB Communication .....</b>	<b>14</b>
4.1	USB Connector .....	14
4.2	Serial Connection to PC.....	14
4.3	Bootmode .....	14
4.4	Config Signals .....	15
4.5	Infineon DAP Debug Connector (10-pin) .....	15
4.6	miniWiggler JDS .....	16
<b>5</b>	<b>Reset .....</b>	<b>16</b>
5.1	CAN Transceiver .....	16
5.2	Schematics .....	17
5.3	List of Material .....	18

## List of Figures

Figure 1	Block Diagram of the AURIX™ TC275 Lite Kit.....	7
Figure 2	AURIX™ TC275 Lite Kit Board View from the Top .....	8
Figure 3	Power Supply Concept .....	9
Figure 4	Signal mapping of the pin headers X1 and X2 .....	10
Figure 5	Signal mapping of the pin headers for Microbus and Shield2Go Connector 1 and 2.....	11
Figure 6	Mapping of Arduino Functions to AURIX™ Pin Functions.....	13

**List of Tables**

Table 1	Overview of the Board Specification .....	6
Table 2	Signal mapping of the 0 Ohm Pin Bridges.....	12
Table 3	AURIX™ Pin Mapping for User LEDs.....	13
Table 4	Debugger Pin Mapping for User LEDs.....	14
Table 5	AURIX™ Push Buttons and Potentiometer.....	14
Table 6	User Startup Modes <sup>1)2)3)</sup> .....	14
Table 7	Pin Assignment of the Cortex™ Debug Connector (X102) .....	15
Table 8	CAN Signals and AURIX™ TC275 Pin Mapping .....	17

## 1 Introduction

This document describes the features and hardware details of the **AURIX™ Lite Kit Series-1** equipped with a **32-Bit Single-Chip AURIX™ TriCore™-based Microcontroller AURIX™ TC275** from Infineon Technologies AG.

It can be used with a range of development tools including Infineon's free of charge Eclipse based IDE **AURIX™ Development Studio** or the Eclipse based "**FreeEntryToolchain**" from Hitecs/PLS/Infineon. AURIX™ Development Studio is a comprehensive environment, including C-Compiler and Multi-core Debugger, Infineon's low-level driver (iLLD), with no time and code-size limitations that enables editing, compiling and debugging application code. The FreeEntryToolchain is a full C/C++ development environment which has a source-level UDE debugger from PLS included and is also based on Infineon low-level driver (iLLD).

Table 1 Table 1 Overview of the Board Specifications shows the overview specifications of the whole board.

**Table 1 Overview of the Board Specification**

CPU Core AURIX™	Manufacturer Order No.	SAK-TC275TP-64F200W DB	
	Type	TC1.6P / TC1.6E	
	P Cores / Checker Cores / E Cores / Checker Cores	2 / 1 / 1 / 1	
	Max Freq.	200 MHz	
	FPU	YES	
	Package	PG-LQFP176-22 package	
	External Crystal Freq.	20 MHz	
Flash Memory AURIX™	4 Mbyte Flash		
Data Memory AURIX™	384 kB usable for EEPROM emulation		
Cache AURIX™	Instruction (P / E)	16 Kbyte / 8 Kbyte	
	Data (P / E)	8 Kbyte / -	
SRAM AURIX™	Size TC1.6P (DSPR/PSPR)	120 Kbyte / 8 Kbyte <sup>2)</sup>	
	Size TC1.6E (DSPR/PSPR)	112 Kbyte / 24 Kbyte <sup>1), 2)</sup>	
	Size LMU	32 Kbyte	
Debugger	Manufacturer Order No.	93LC46B-I/SN	
	External Flash Size	1 Kbyte	
	External Crystal Freq.	12 MHz	
	Debbug Connectors	USB3.0 or DAP	
Board Dimensions	66,3 x 131,0 mm <sup>2</sup>		
Power	<ul style="list-style-type: none"> <li>On-Board Debugger Micro-AB USB interface</li> <li>5V external powering</li> </ul>		
Connectors	<ul style="list-style-type: none"> <li>Most AURIX™ pins available on expansion connectors (X1, X2)</li> <li>Two Infineon Shield2Go connectors</li> <li>Arduino compatible connectors for 3.3V</li> <li>mikroBUS™ connector</li> <li>Micro-USB connector</li> <li>DAP Debug connector</li> <li>CAN connector</li> </ul>		
Others	<ul style="list-style-type: none"> <li>CAN transceiver TLE9251VSJ from Infineon</li> <li>1 user push-button, 3 user LEDs</li> </ul>		

**Table 1 Overview of the Board Specification**

- Reset push-button
- Potentiometer (10kOhm) for variable analog input

1) Address range starts at lowest address defined in the User's Manual. For reference see the Memory Maps chapter of the User's Manual.  
 2) To ensure the processor cores are provided with a constant stream of instructions the Instruction Fetch Units will speculatively fetch instructions from the up to 64 bytes ahead of the current PC. If the current PC is within 64 bytes of the top of an instruction memory the Instruction Fetch Unit may attempt to speculatively fetch instruction from beyond the physical range. This may then lead to error conditions and alarms being triggered by the bus and memory systems. It is therefore recommended that the upper 64 bytes of any memory be unused for instruction storage.

These boards are neither cost nor size optimized and do not serve as a reference design.

### 1.1 Block Diagram

- The block diagram in Figure 1 shows the main components of the AURIX™ Lite-Kit V1.1 and their interconnections.

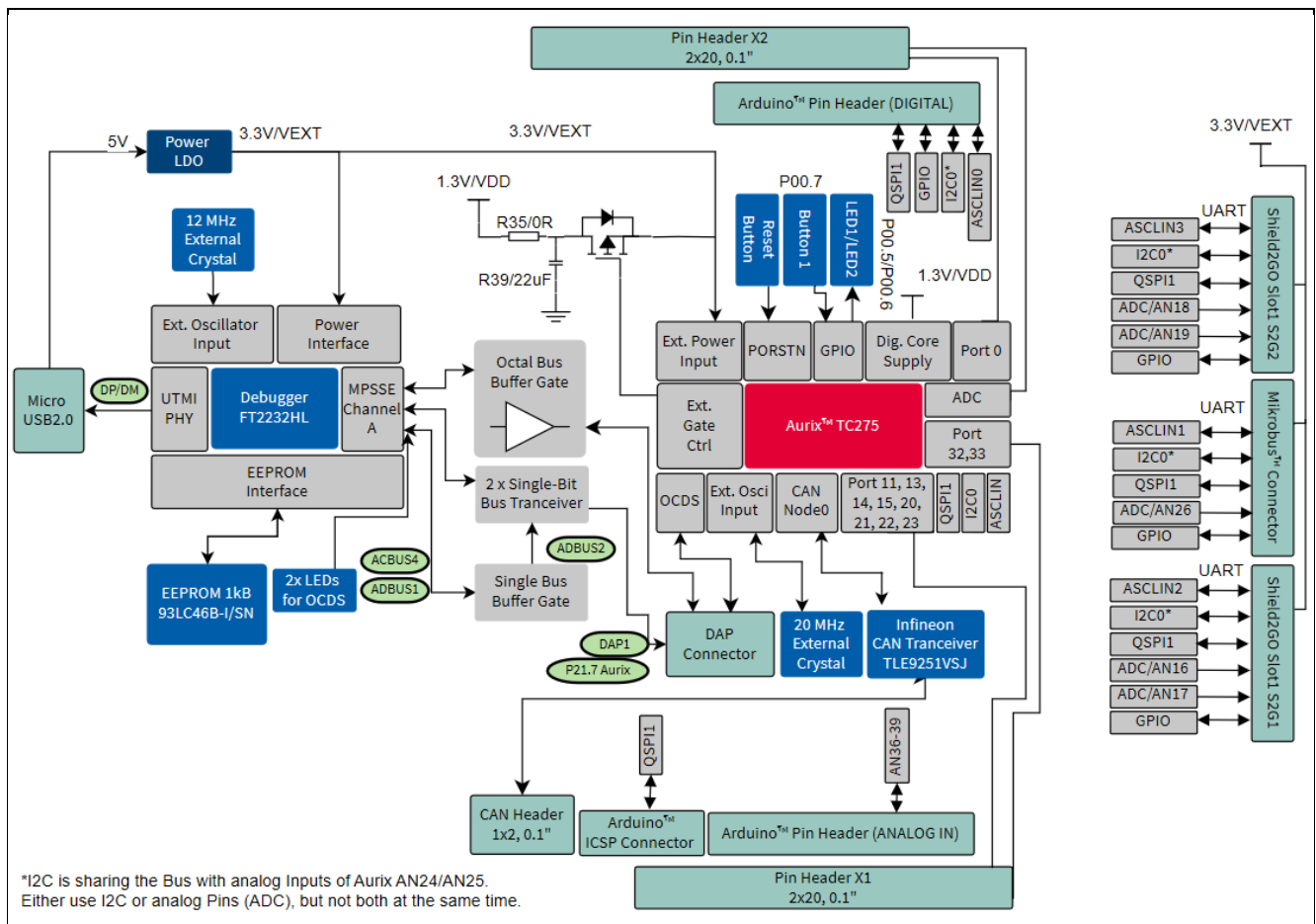

**Figure 1 Block Diagram of the AURIX™ TC275 Lite Kit**

## 2 Hardware Description

The following chapters give a detailed description of the board hardware and how it can be used. The different assembly versions of the kits series are shown in Figure 2.

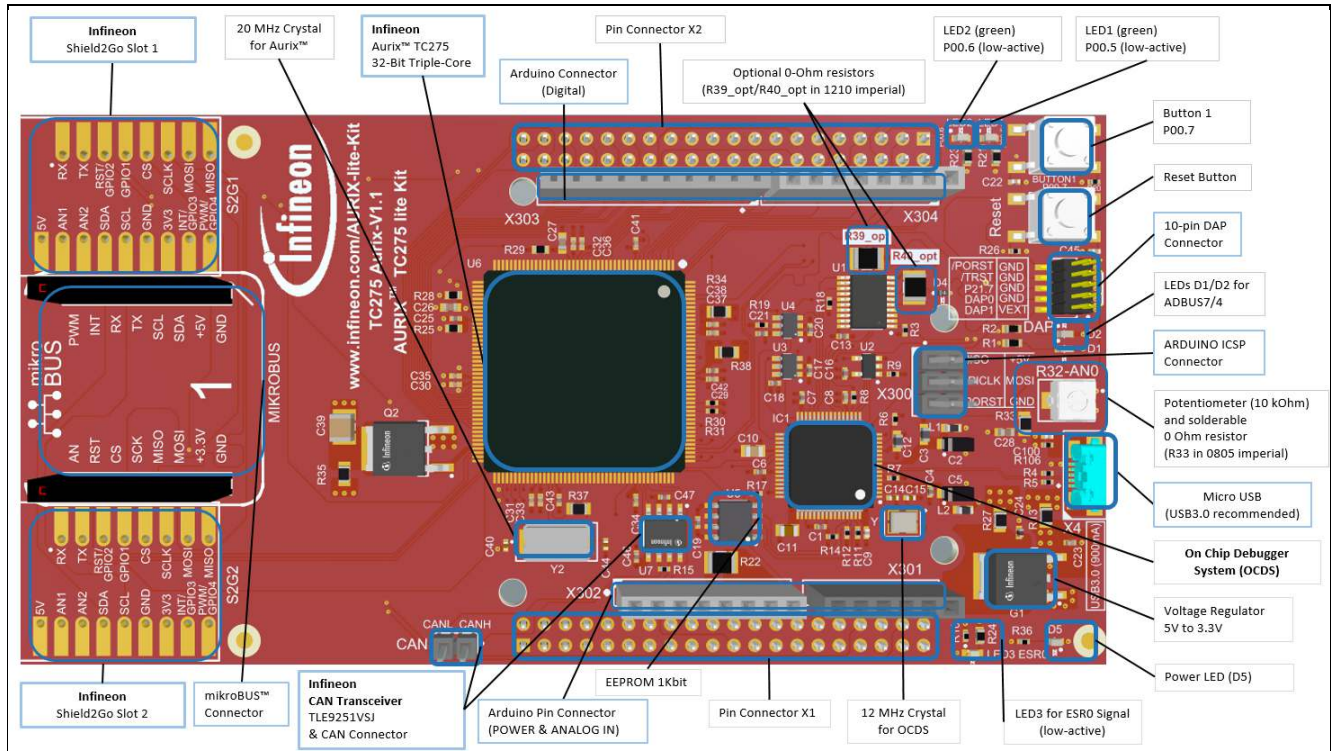

**Figure 2 AURIX™ TC275 Lite Kit Board View from the Top**

### 2.1 Power Supply

The AURIX™ TC275 Lite-Kit - V1.1 must be supplied by an external DC power supply, therefore using the **micro USB plug X4 is recommended**.

The green Power LED D5 indicates the presence of the generated 3.3 V supply voltage.

If the board is powered via a USB plug, it's not recommended to apply an additional power supply to one of the power pins (VEXT, +5V, VDD\_USB) on the pin headers X1, X2, the Arduino Power header X302, the Shield2GO slots or the mikroBus™ connectors, because there is no protection against reverse current into the external power supply. These power pins can furthermore be used, to power an external circuit and therefore used as an output. But care must be taken to not draw more current than USB can deliver. A PC as USB2.0 host typically can deliver up to 500 mA current and USB3.0 up to 900mA. For best performance, we recommend to use USB3.0. If higher currents are required and in order to avoid damages on the USB host, the use of an external USB power supply unit, which is able to deliver higher currents, is possible.

**Note:** The LDO G1, that transfers the input voltage to 3.3V, has a maximum output current rating of 1A. Therefore, if an external 5V USB power supply host is used, the maximum current consumption is limited to 1A. Do not apply any additional voltage on the VEXT Pins, because they are directly connected to the output of the LDO G1 and further backwards voltage can damage or destroy the LDO. Furthermore, do not apply multiple sources on the power pins, otherwise you risk to damage and destroy the board.

However, more options are possible, but therefore, caution is necessary, to avoid any damage to the board and your supplies. Please ensure that X4 is **not** supplied by any power source or PC, for all mentioned configurations below. Otherwise, **you risk to damage your source or PC**.



Ensuring the mentioned points, following supply options are possible with a +5V power source:

- Option 2: Supply +5V on either one of the +5V Pins at X302 Arduino power connector
- Option 3: Supply +5V on either one of the VDD\_USB Pins at X1 or X2 connector

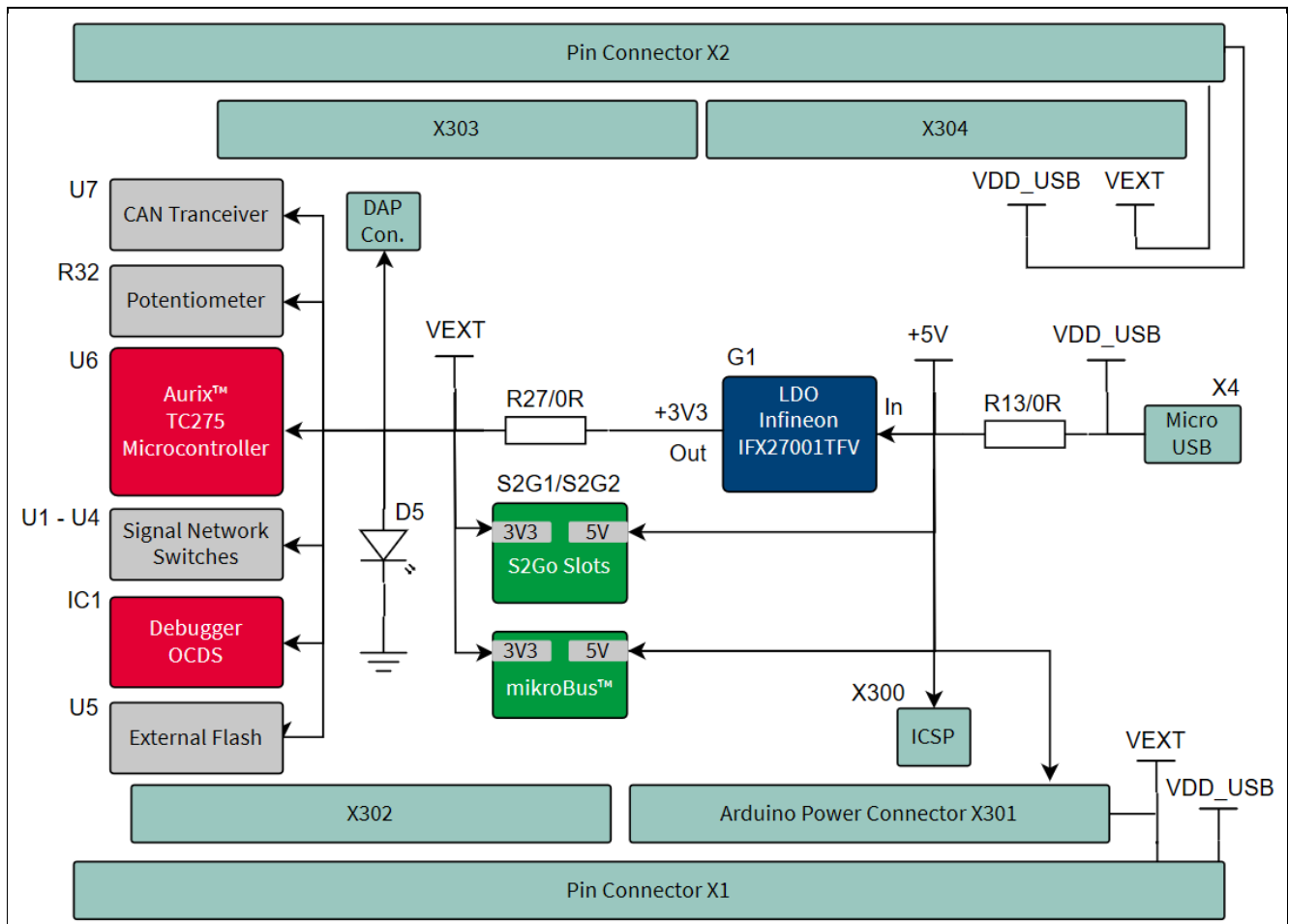

**Figure 3 Power Supply Concept**

- Option 4: Note that for this option, the CAN Tranceiver is not working. By **desoldering** the resistor **R27** (size 0805 imp), you can use an external +3V3 source on either one of the VEXT pins at X1, X2 connectors or the +3V3 pin on the X302 Arduino power connector, to power the board.

**Note:** Do **not** apply any voltage on the mentioned power pins, if the USB is plugged in. Furthermore, do not apply multiple sources on the power pins, otherwise you risk to damage and destroy the board.

### 3 Pinout of X1 and X2 connectors

The pin headers X1 and X2 can be used to extend the evaluation board or to perform measurements on the AURIX™ TC275. Figure 4 shows the available GPIOs / signals at these pin headers. The pin table is also printed onto the bottom side of the PCB.

Pin Header X1				Pin Header X2						
GND	1	2	VEXT	GND	1	2	VDD_USB			
P33.11	3	4	P33.12	TXDCAN	P00.0	3	4	P00.1	RXDCAN	
P33.13	5	6	P32.0		P00.2	5	6	P00.3		
P23.1	7	8	P23.0	LED2	P00.6	7	8	P00.5	LED1	
P23.3	9	10	P23.2		P00.8	9	10	P00.7	Button1	
P23.5	11	12	P23.4		P00.10	11	12	P00.9		
MRST	P22.1	13	14	P22.0	MTR	P00.12	13	14	P00.11	
	P21.0	15	16	P22.2	SS	VAREF1	15	16	AN47	
MDC	P21.2	17	18	P22.3	SCLK	AN46	17	18	AN45	
	P21.4	19	20	P21.3	MDIO	AN44	19	20	AN7	
	P20.10	21	22	P21.5		AN6	21	22	AN5	
TXD2_S2G2	P20.0	23	24	P20.1		AN4	23	24	AN3	
RXD2_S2G2	P20.3	25	26	ESR1_N	ESR1	AN2	25	26	AN1	
ESR0	ESR0_N	27	28	P20.14	Potentiometer	AN0	27	28	P33.0	
SDA0	P15.5	29	30	PORST_N	Reset	P33.1	29	30	P33.2	
SCL0	P15.4	31	32	P11.12		P33.3	31	32	P33.4	
CRSDV	P11.11	33	34	P11.10	CS_S2G2	P33.5	33	34	P33.6	
RXD1	P11.9	35	36	P11.6		P33.7	35	36	P33.8	RXD1_S2G1
TXD0	P11.3	37	38	P11.2	CS_S2G1	TXD1_S2G1	P33.9	37	38	P33.10
VDD_USB	39	40	GND			VEXT	39	40	GND	

**Figure 4** Signal mapping of the pin headers X1 and X2

### 3.1 Shield2Go and MikroBus™ Pinout

The pin connectors for the Shield2Go Connectors 1 and 2 and the mikroBus™ can be used to extend the evaluation board or to perform measurements on the AURIX™ TC275. Figure 5 shows the available signals at these connectors. The pin table is also printed onto the top and bottom side of the AURIX™ TC275 Lite-Kit.

Shield2Go Connector 1			Shield2Go Connector 2		
<b>AURIX™ Pins</b>			<b>AURIX™ Pins</b>		
1	+5V	5V			
2	AN16	AN1	RX	P33.8	10
3	AN17	AN2	TX	P33.9	11
4	P13.2 <sup>2)</sup>	SDA	RST/GPIO 2	P20.9	12
5	P13.1 <sup>2)</sup>	SCL	GPIO1	P32.2	13
6	GND	GND	CS	P11.2	14
7	VEXT	3V3	SCLK	P10.2 <sup>1)</sup>	15
8	P00.4	INT/GPIO3	MOSI	P10.3 <sup>1)</sup>	16
9	P20.12	PWM/GPIO4	MISO	P10.1 <sup>1)</sup>	17
<b>AURIX™ Pins</b>			<b>AURIX™ Pins</b>		
1	+5V	5V			
2	AN18	AN1	RX	P20.3	10
3	AN19	AN2	TX	P20.0	11
4	P13.2 <sup>2)</sup>	SDA	RST/GPIO2	P20.10	12
5	P13.1 <sup>2)</sup>	SCL	GPIO1	P32.3	13
6	GND	GND	CS	P11.10	14
7	VEXT	3V3	SLCK	P10.2 <sup>1)</sup>	15
8	P10.8	INT/GPIO3	MOSI	P10.3 <sup>1)</sup>	16
9	P20.13	PWM/GPIO4	MISO	P10.1 <sup>1)</sup>	17
<b>mikroBus™ Connector</b>					
1	AN26	AN	PW		16
			M	P2.8	
2	P10.6	RST	INT	P10.7	15
3	P10.0	CS	RX	P15.1	14
4	P10.2 <sup>1)</sup>	SCK	TX	P15.0	13
5	P10.1 <sup>1)</sup>	MISO	SCL	P13.1 <sup>2)</sup>	12
6	P10.3 <sup>1)</sup>	MOSI	SDA	P13.2 <sup>2)</sup>	11
7	VEXT	3.3V	5V	+5V	10
8	GND	GND	GND	GND	9

**Figure 5** Signal mapping of the pin headers for Microbus and Shield2Go Connector 1 and 2

Note:

<sup>1)</sup> The SPI buses MOSI, MISO and SCK are shared on the Shield2GOs-, mikroBus™- and Arduino connectors.

<sup>2)</sup> The I2C buses SCL and SDA are shared on the Shield2GOs, mikroBus™ and Arduino connectors and are additionally connected with analog Inputs AN24 and AN25. You can **not** use I2C and analog reading functions of AN24/AN25 simultaneously.

### 3.2 Solderable Pin Bridges

Some resistor bridges enable/disable or changing functions of specific signals in Table 2.

To disable the signals, the resistors have to be removed. To enable, the resistor has to be assembled.

**For example:** Desoldering the initially assembled resistor R33, disables the Potentiometer and the analog Signal AN0 of the AURIX, making it usable for other purposes.

**Table 2 Signal mapping of the 0 Ohm Pin Bridges**

Resistor	Res.	Assembled	Signal	Size (imperial)	Comment
R31	1kΩ	no	P14.3 (AURIX)	0402	Assemble if needed, but overboots then P10.5/P10.6
R37	0Ω	yes	XTAL2 (AURIX)	0805	Serial resistor to reduce oscillator amplitude if needed.
R39_opt	0Ω	no	USR0 (ADBUS6) (Debug)	1210	Placeholder, do not assemble
R40_opt	0Ω	no	USR8 (ACBUS5) (Debug)	1210	Placehoder, do not assemble

### 3.3 Arduino Compatible Connector

The mapping of GPIOs and AURIX™ pin functions to Arduino compatible functions can be found in Figure 5. The Arduino compatible connector supports

- SPI interface (SPI\_XXX)
- I2C interface (I2C\_XXX)
- UART interface (UART\_XXX)
- PWM signal outputs (PWM0-13)
- ADC input (ADC0-5)
- Interrupt input (INT0-1)

Note that all pins are capable of offering more functions than mentioned in Figure 5. For more information about all pin functions, we want to refer you to the [AURIX™ TCX27X family datasheet](#) (page 13 ff).

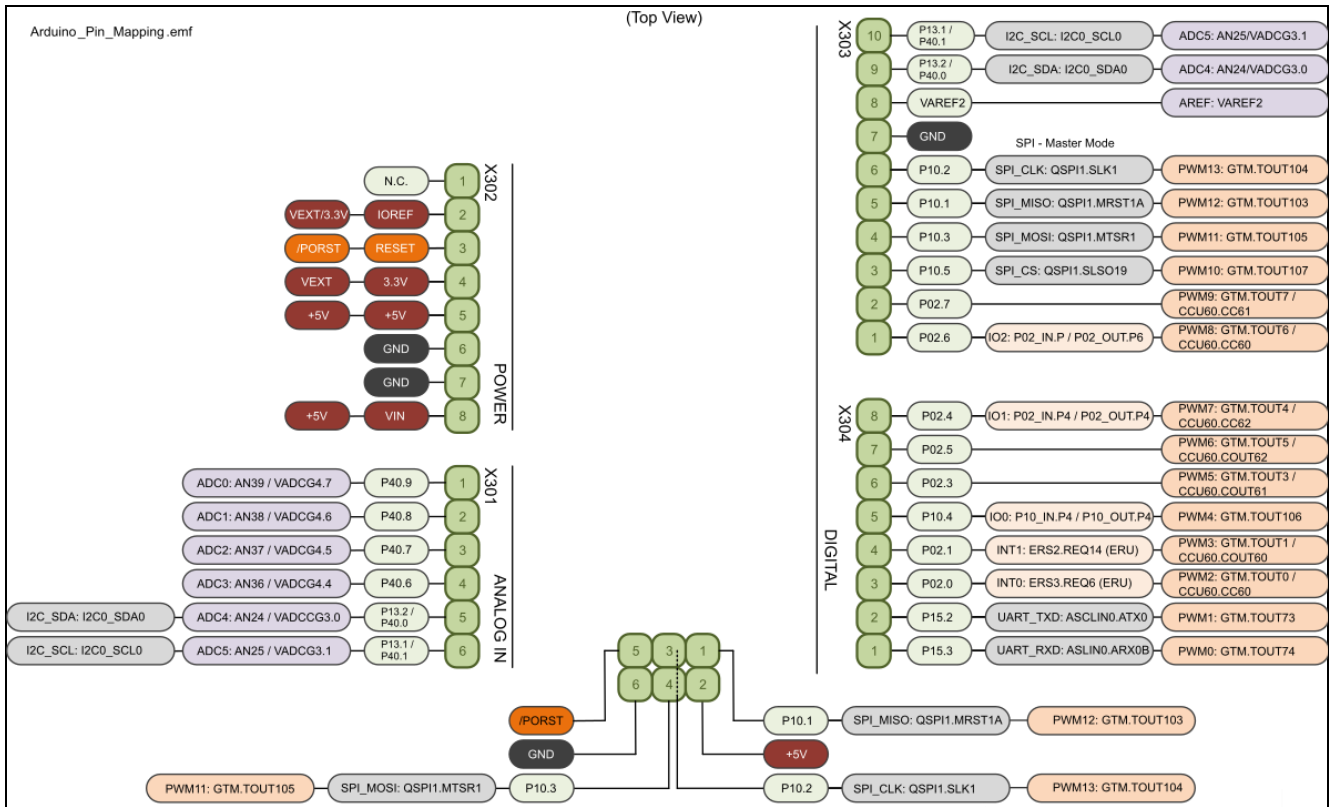

**Figure 6 Mapping of Arduino Functions to AURIX™ Pin Functions**

The **AURIX™ TC275 Lite-Kit** works with 3.3V logic levels. Therefore, any board that works with 5V logic levels, cannot be used.

Analog input signals ADC0-5 are limited to a voltage which is smaller or equal than VAREF2 with VAREF2 = VDDM = 3.3V. Primarily, ADC0 to ADC3 should be used as analog input, because there is no additional circuit connected to these pins, whereas ADC4 and ADC5 have additional circuitry. Parallel operation of I2C and ADC4 / ADC5 is not possible, because they share the same pins at the Arduino connector X301 and X303.

### 3.4 User Push Buttons, User LEDs and Potentiometer

The **AURIX™ TC275 Lite-Kit** provides one user push button, a reset button, two LEDs and one potentiometer. Additionally, LED3 can be used for visualizing an emergency stop function at ESR0 (emergency service request). The LEDs D1 and D2 can be used for visualizing activities at the ADBUS7 and ADBUS4 tracks of the Debugger. The port pins used can be found in Table 3, Table 4 and Table 5.

**Table 3 AURIX™ Pin Mapping for User LEDs**

Name	AURIX™ Pin	Color	Active
LED1	P00.5	green	Low-active (pull against GND)
LED2	P00.6	green	Low-active (pull against GND)
LED3	ESR0	red	Low-active (pull against GND)

**Table 4 Debugger Pin Mapping for User LEDs**

Name	Debugger Pin	Color	Active
D1	ADBUS7	green	Low-active (pull against GND)
D2	ADBUS4	green	Low-active (pull against GND)

**Table 5 AURIX™ Push Buttons and Potentiometer**

Name	AURIX™ Pin	Active
Button1	P00.7	Low-active (pull against GND)
Reset	/PORST	Low-active (pull against GND)
R32 (10kΩ)*	AN0	-

\*Note: Desoldering resistor R33, enables AN0 for other functions, but disables the Potentiometer functionality.

## 4 Debugging and USB Communication

The **AURIX™ TC275 Lite-Kit** supports debugging via 2 different channels:

- On-board debug probe via the the microUSB X4
- 10-pin DAP Connector

### 4.1 USB Connector

The USB connector is used for connection to a PC. Via the USB it is possible to power the board, using the ASCLIN0 as serial connection via USB and Debugging via DAS.

**NOTE: Before connecting the board to the PC, make sure that the actual DAS software is installed on the PC.**

For actual DAS software please contact your local FAE.  
The software can also be found on:

[DAS website](#)

### 4.2 Serial Connection to PC

After the first connection of USB to a PC the needed driver will be installed automatically. During this there will be created a new COM port on PC. This COM port can be used to communicate with the board via ASCLIN0 of the device. Per default the ASCLIN0 is used on P14.0 and P14.1 (e.g. Generic Bootstrap Loader).

### 4.3 Bootmode

**Table 6 User Startup Modes <sup>1)2)</sup>**

HWCFG[5...3]	Type of Boot	2	3	4
XX1	Start-up mode is selected by Boot Mode Index	X	X	OFF
110	Internal Start from Flash	OFF	OFF	ON
100	Alternate Boot Mode, Generic Bootstrap Loader on fail (P14.0/P14.1)	ON	OFF	ON

000	Generic Bootstrap Loader (P14.0/P14.1)	ON	ON	ON
-----	--	----	----	----

- 1) The shadowed line indicates the default setting.  
 2) 'x' represents the don't care state.

## 4.4 Config Signals

**Table 7 Config Signals**

Short Name	Description	Comment
P14.3	HWCFG3 (Boot from pins / Boot from Flash BMI)	Resistor R31(1kΩ/0402 imp) can be assembled and therefore would pull HWCFG against GND. Take care, because this overrides P10.5/P10.6
P14.5	HWCFG1 (EVR33OFF / EVR33ON)	Resistor R30 (1kΩ/0402 imp) pulls signal against GND and is assembled initially.
P10.5	HWCFG4 (see boot configuration Table 6)	-
P10.6	HWCFG5 (see boot configuration Table 6)	-

## 4.5 Infineon DAP Debug Connector (10-pin)

Infineon's 10-pin Device Access Port Debug Connector (DAP) is a two-wire tool access port for microcontrollers and similar devices. It allows robust high speed connections over a long cable for automotive applications. The pin assignment of the DAP Debug Connector is shown in Table 8. The board comes with a DAP connector. You can connect a DAP hardware here. If you use this connector make sure that the miniWiggler JDS is not active (LED D2 is off). For more information, we refer you to the [DAP Connector Manual](#).

**Table 8 Pin Assignment of the DAP Debug Connector**

Pin	Name	AURIX™ Pin	Direction	Description
1	VREF	VEXT	O	Supply voltage from the target system. The voltage has to be strong enough to supply the target side of the level shifters within the tool hardware up to about 20 Mhz DAP operating frequency. The required supply current is in the range of 5 mA, mainly caused by signal switching. It can be reduced by lowering frequency and capacitance. Beyond 20 MHz the tool hardware has to supply the level shifter from another source and use this pin just as a voltage reference
2	<b>DAP1</b>	TMS	IO	DAP: Data pin.
	SPD		IO	SPD: Data pin.
	UART		IO	Single-wire UART. Serial communication interface (e.g. used for Bootstrap Loader BSL).
3	GND	GND		Recommended pin for signal return of DAP1 for high frequency impedance matching.
4	<b>DAP0</b>	TCK	I	DAP: Clock.
	SUP		I	SPD: Optional user pin value for feedback into the target system. Otherwise reserved
5	GND	GND		Recommended pin for signal return of DAP0 for high frequency impedance matching.
6	<b>DAP2</b>	P21.7	IO	DAP: Optional second data pin.
	USER0		IO/O	Generic signal that can be used for non specified functions.

Pin	Name	AURIX™ Pin	Direction	Description
7	KEY (GND in cable)	GND	-	If the recommended connector with keying shroud is not used, this pin provides another option to enforce polarization. In that instance this pin is removed from the target connector and the associated jack in the cable connector closed with a plastic pin for example.
8	<b>DAP3</b>	/TRST	IO	DAP: Optional third data pin.
	USER1		IO/I	Generic signal that can be used for non-specified functions.
	(DAPEN)		I	Optional indicator that the tool is connected. This can be used to enable the DAP interface of the device
9	GND	GND		Supply ground.
10	RESET	/PORST	IO	Target reset signal. Open drain active low signal. May be used bi-directionally to drive or sense the target reset signal. Usually driven by the tool to reset the target system. The target system is responsible for providing a pull-up to VREF on this signal to establish a logic one. The resistor shall not have a value less than 1 kOhms.

## 4.6 miniWiggler JDS

The miniWiggler JDS is a low cost debug tool which allows you access to the DAP of the device. Make sure that you have the latest DAS release. Debugging is possible via the DAS Server 'UDAS'. Please contact your preferred debug vendor for support of DAS. If you have connected the board to the PC and there runs the DAS server, then a working connection is visible via the green LED D2 (ADBUS4). The status LED D1 (ADBUS7/green) is switched on/off through the DAS Server, depending on the used debugger (client).

**IMPORTANT: Make sure that there is no or a tristated connection on the DAP connector if the LED D1 is on.**

## 5 Reset

The power on reset input pin (/PORST) of the AURIX™ TC27x family is a bi-directional input/output intended for external triggering of power-related resets. If the PORST pin remains asserted after a power event then the reset will be extended until it is deasserted. This does not replace the ESR pins functional reset. An internal pull-up resistor (2.2kΩ) keeps the PORST# pin high during normal operation. A low level at this pin will force a hardware reset. In case of a MCU internal reset the PORST# pin will drive a low signal.

A reset signal can be issued by

- the on-board Reset Button ("RESET")
- the on-board debug IC FT2232HL (IC1.27 – ACBUS1)
- the on-board DAP connector (DAP.10)
- the Arduino Power Header (X302.3, "/PORST")
- the pin header X1 (X1.30, "/PORST")

An AURIX™ internal circuit always ensures a save Power-on-Reset. AURIX™ TC275 Lite-Kit does not require any additional external components to generate a reset signal during power-up. For more informations, please refer to the AURIX™ TC27X [Datasheet](#) or [User Manual](#).

### 5.1 CAN Transceiver

The **AURIX™ TC275 Lite-Kit** provides a CAN interface via the CAN connector. The [TLE9251V](#) is the latest Infineon high-speed CAN transceiver generation, used inside HS CAN networks for automotive and also for industrial applications. It is designed to fulfill the requirements of ISO 11898-2 (2016) physical layer specification and respectively also the SAE standards J1939 and J2284. The CAN buses (signals CANH, CANL) are terminated with by a 120Ohm resistor. The transceiver is connected to the TriCore™ device CAN node 0.



The transceiver is in stand-by mode per default. To switch the transceiver to normal operating mode the transceiver pin STB (signal name #NEN) must be driven low from the CPU. To use the CAN pins see Table 9.

**Table 9 CAN Signals and AURIX™ TC275 Pin Mapping**

<b>Signal Name</b>	<b>Pin No. at CAN Pin Header</b>	<b>AURIX™ Pin, AURIX™ Function</b>	<b>Ass. Reg./ I/O Line</b>
CANH	1	-	-
CANL	2	-	-
CAN_TX	-	P20.8, CAN node 0 output	TXDCAN0
CAN_RX	-	P20.7, CAN node 0 input	RXDCAN0B
#NEN	-	P20.6, GPIO	P20.6 OUT

## 5.2 Schematics

Index	
Page	Schematics Page Name
01	Cover Sheet / Revision History
02	OCDS
03	Power_a_Connector
04	CPU
05	
06	
07	
08	
09	
10	

01\_Revision\_History.SchDoc

Revision History					
Rev.	Rel.	Date	Author	Description	Page(s)
V1.0		12/2019	R.B.	Eval Board	

# TC27X SmartCar

## Default\_Assembly

### V1.1



Infineon Technologies AG  
Infineon Technologies AG  
-

12/2019

**LEGAL DISCLAIMER**  
 THE INFORMATION GIVEN IN THIS DOCUMENT IS GIVEN FOR ILLUSTRATING PURPOSES ONLY. THE RECIPIENT OF THIS DOCUMENT MUST VERIFY ANY FUNCTION DESCRIBED HEREIN IN THE REAL APPLICATION. INFINEON TECHNOLOGIES HEREBY DISCLAIMS ANY AND ALL WARRANTIES AND LIABILITIES OF ANY KIND (INCLUDING WITHOUT LIMITATION WARRANTIES OF NON-INFRINGEMENT OF INTELLECTUAL PROPERTY RIGHTS OF ANY THIRD PARTY) WITH RESPECT TO ANY AND ALL INFORMATION GIVEN IN THIS DOCUMENT.

 <b>Infineon Technologies AG</b> Infineon Technologies AG			
Title		TC27X SmartCar	
Variant		Default_Assembly	Approved <Appr.>
Size:	Document Name	Rel.	Rev.
A3	01_Revision_History.SchDoc	-	V1.1
Author: -			
Date: 26.06.2020		Time: 14:55:17	SVN Revision: da75247807cb30a8ab86d75f81b5
© Infineon Technologies AG 2019. All Rights Reserved.			Sheet 1 of 4

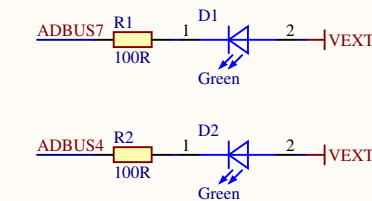

Signal Network Switches

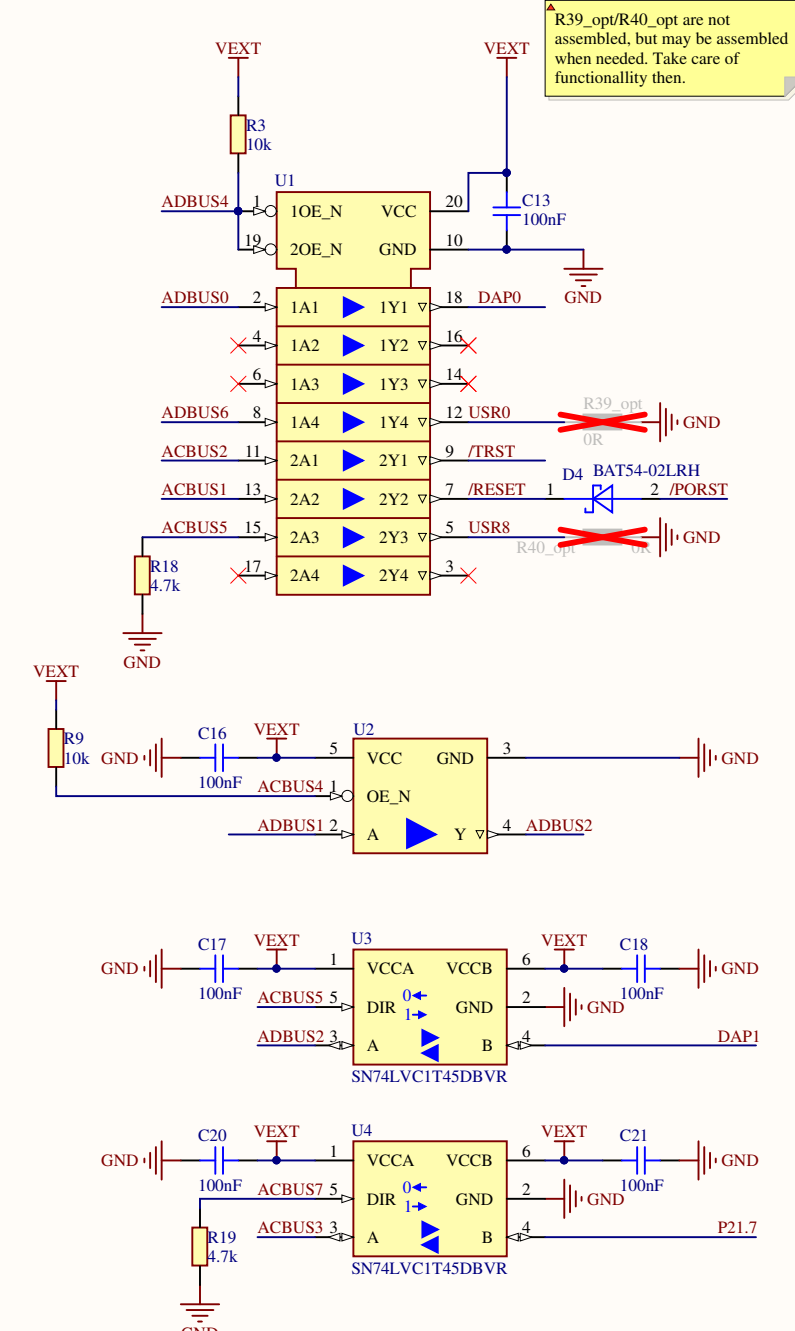

Title TC27X SmartCar			
Variant Default_Assembly			Approved <Appr.>
Size: A3	Document Name: 02_OCDS.SchDoc	Rel.:	Rev. V1.1
Author: -		Date: 26.06.2020	Time: 14:55:18
© Infineon Technologies AG 2019. All Rights Reserved.		SVN Revision: da75247807cb30a8ab86d75f81b5	Sheet 2 of 4

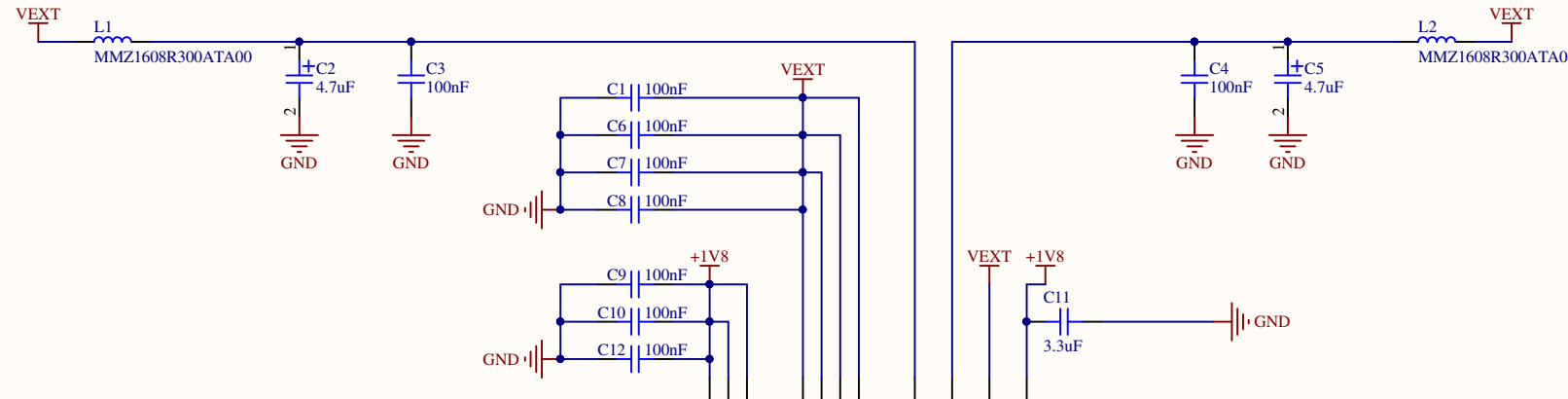

USB Connector

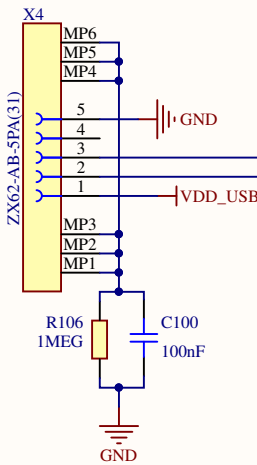

R7 should be at least +/-1 %

External Flash Unit

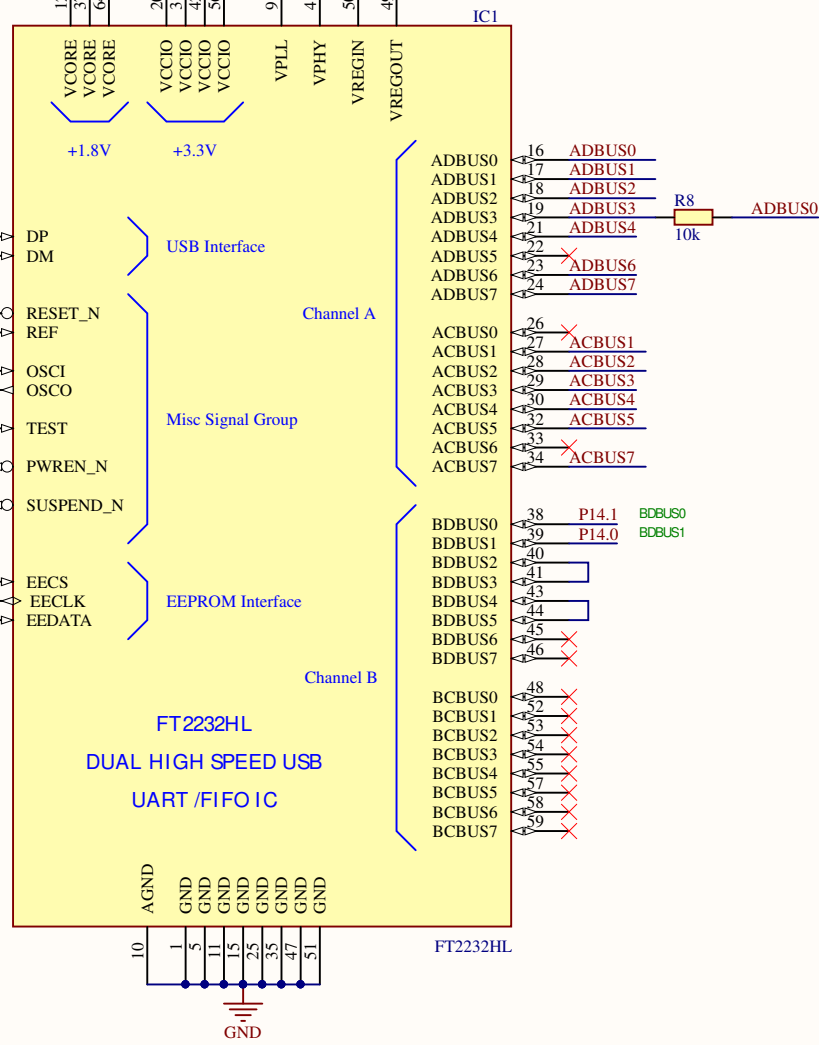
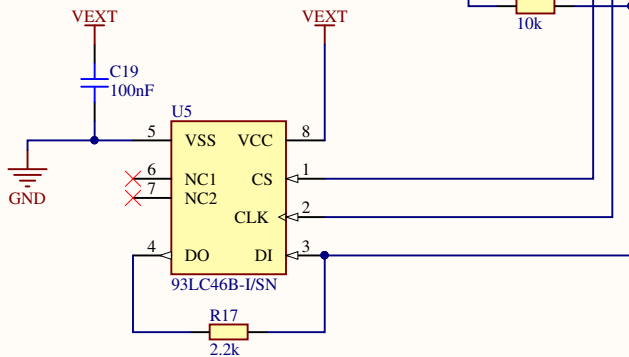

Ardui no Connector & X1/X2

03\_Power\_a\_Connector.SchDoc

Buttons & LEDs

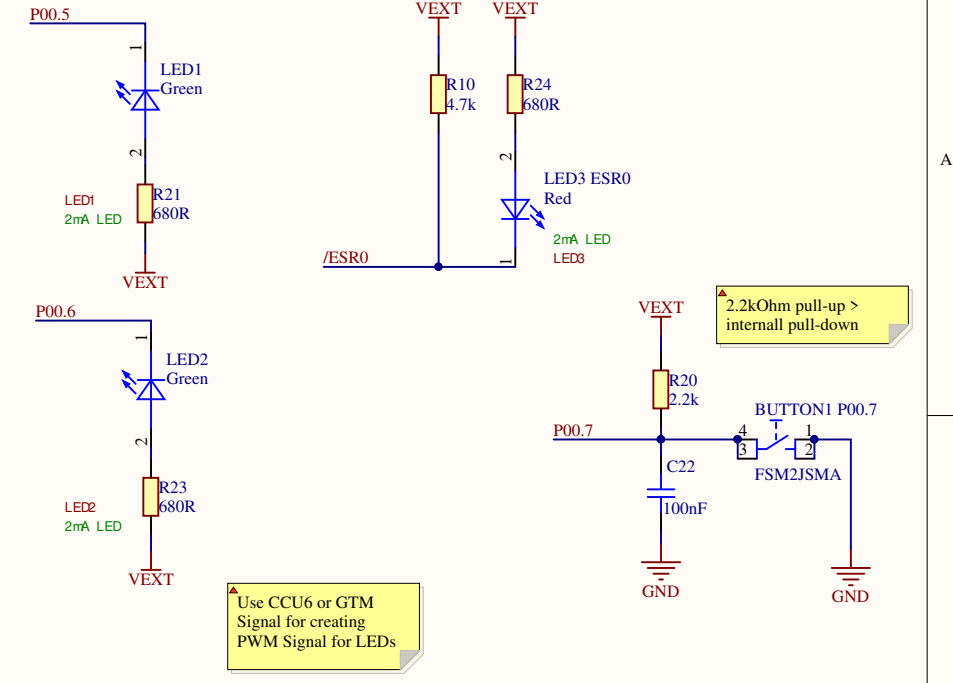
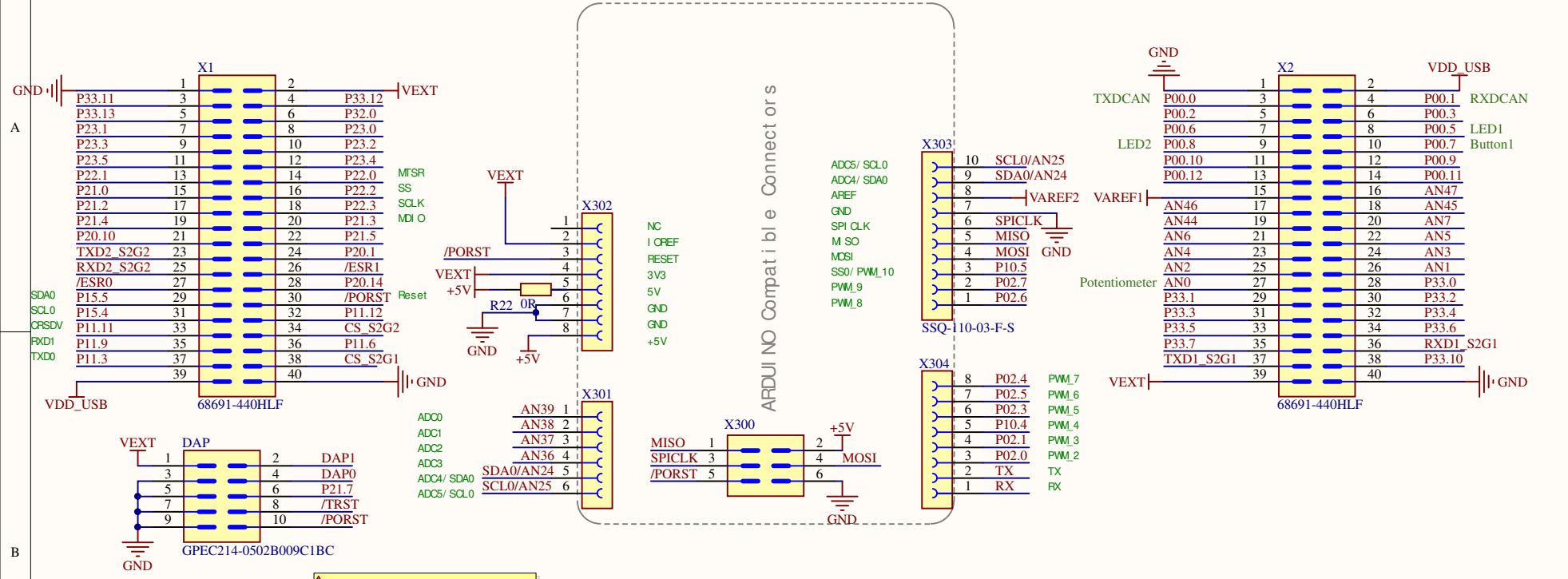

Power & Power LED

Note: 0 Ohm resistors (R13/R27) should have >1000 mW, due to tolerances of the resistor and the max. current of 1000mA of the LDO. P = R\*I^2

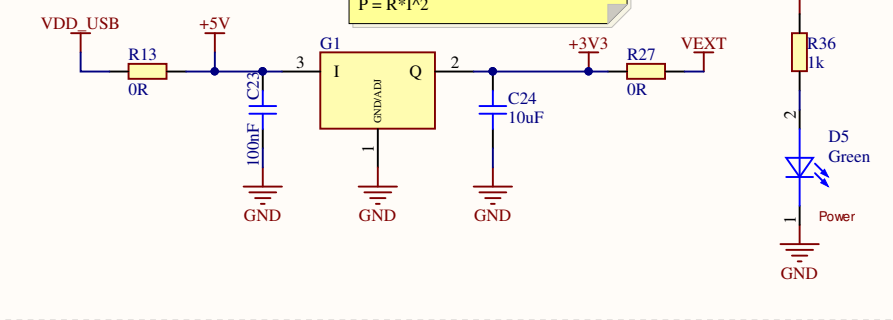

Power of the AURI X TC275

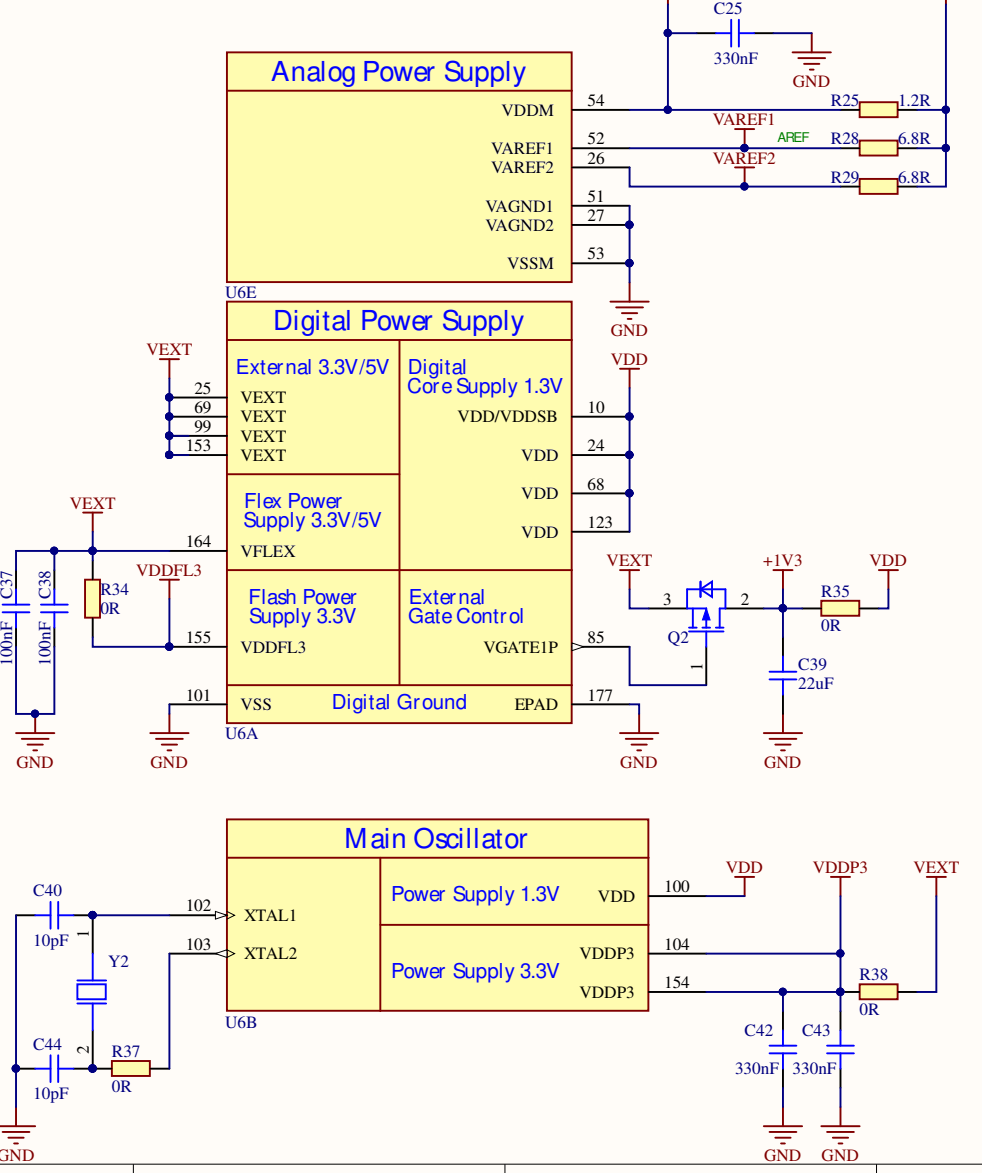

Reset Circuit of AURI X TC275

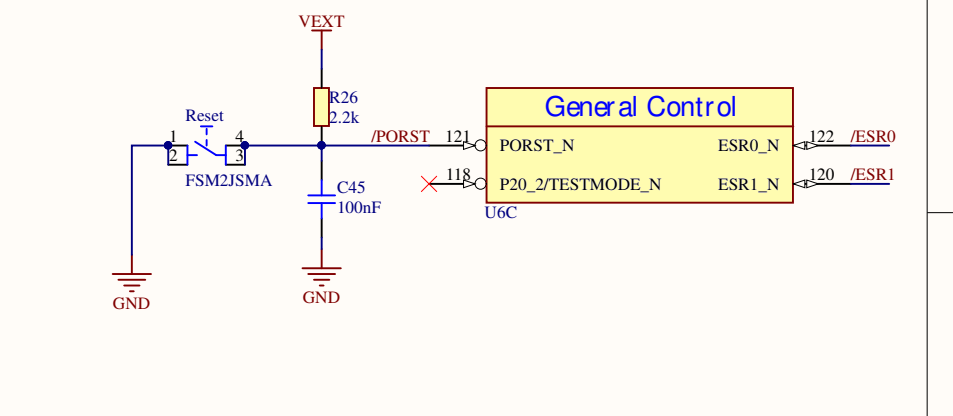

Mikrobos

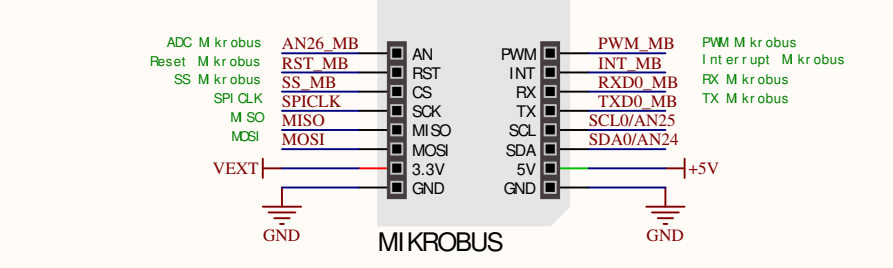

AURI X TC275 Capacitors

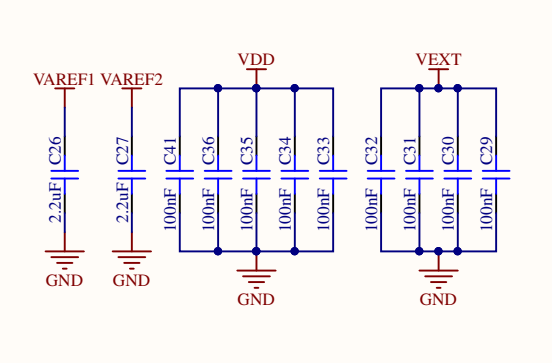

Potentiometer

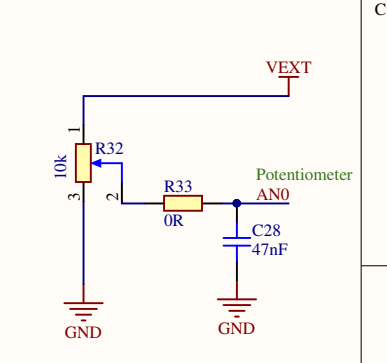

Shield2Go Connectors

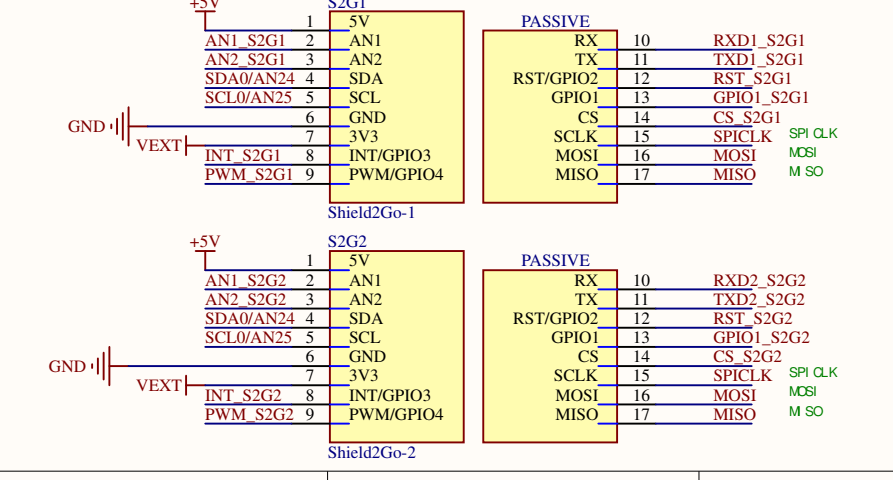

**Infineon Technologies AG**

Infineon Technologies AG

Title		TC27X SmartCar	
Variant	Default_Assembly	Approved	<Appr.>
Size:	Document Name	Rel.	Rev.
A3	03_Power_a_Connector.SchDoc	-	V1.1
Author:	-		
Date:	26.06.2020	Time:	14:55:19
© Infineon Technologies AG 2019. All Rights Reserved.		SVN Revision:	da75247807cb30a8ab86d75f81b5
Sheet 3		of 4	

# Analog Circuit of AURI X TC275

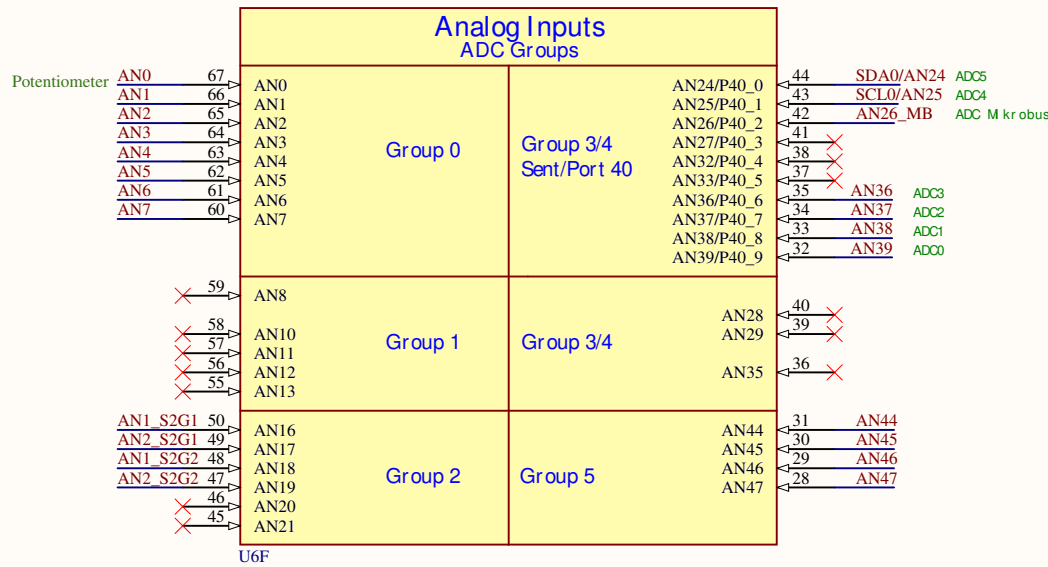

# DAP Control of AURI X TC275

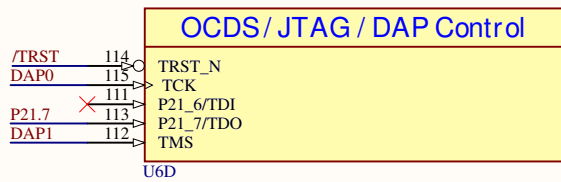

# CAN Transceiver

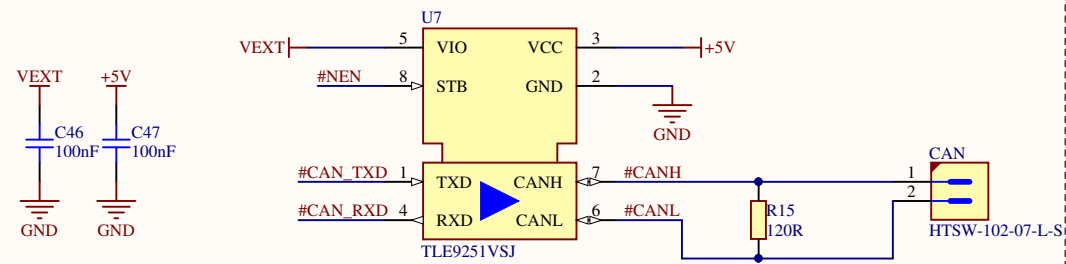

# 04\_CPU.SchDoc

## Ports of AURI X TC275

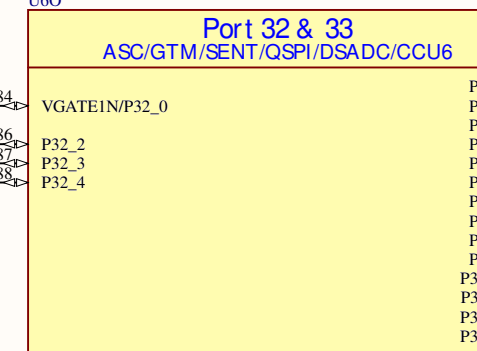
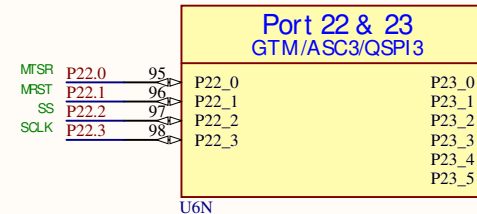
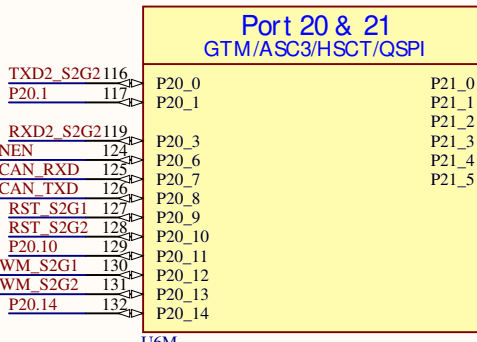
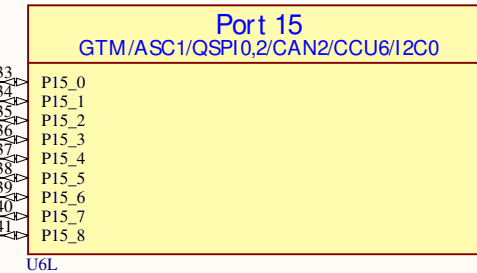
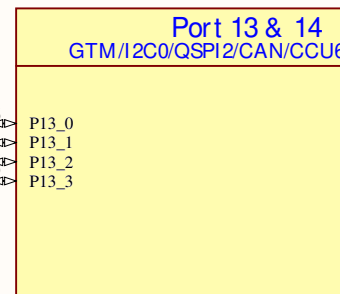
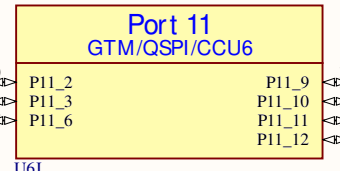
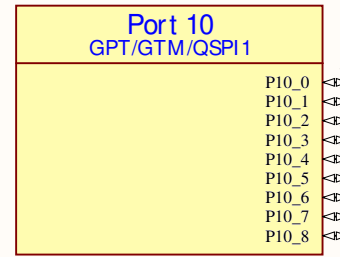
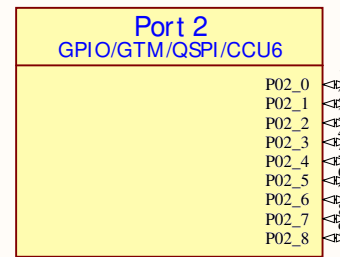
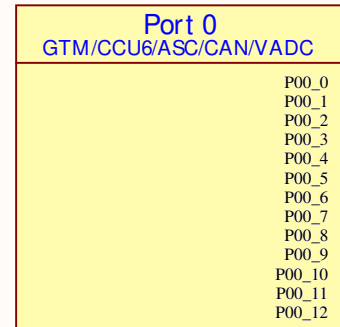

-Resistor (R31) at P14.3 can be assembled manually. But then overboots P10.5/P10.6  
 -Resistor (R30) at P14.5 is mandatory



5.3 List of Material

#	Quantity	Designator	Value	Description	Manufacturer Order Number	Fitted / Non Fitted	PCB Side
1	2	BUTTON1 P00.7, Reset	FSM2JSMA	Micro Miniature Pushbutton Switch	FSM2JSMA	YES	TOP
2	13	C1, C4, C6, C7, C13, C16, C17, C18, C19, C20, C21, C46, C47	100nF	Multilayer Ceramic Chip Capacitor	CGA2B1X7R1C104K050BC	YES	TOP
3	2	C2, C5	4.7uF	Surface Mount Tantalum Molded Capacitor	T491A475K010AT	YES	TOP
4	2	C3, C12	100nF	Surface Mount Multilayer Ceramic Chip Capacitor	C0603C104J8RAC	YES	TOP
5	13	C8, C23, C29, C30, C31, C32, C33, C34, C35, C36, C37, C38, C41	100nF	General Purpose Dielectric Ceramic Capacitor	0402YD104KAT2A	YES	TOP
6	4	C9, C22, C45, C100	100nF	Surface Mount Multilayer Ceramic Chip Capacitor	C0402C104K9RACTU, C0402T104K4RACTU	YES	TOP
7	1	C10	100nF	Surface Mount Multilayer Ceramic Chip Capacitor	C0805C104J5RAC	YES	TOP
8	1	C11	3.3uF	Chip Monolithic Ceramic Capacitor	GRM219R61A335KE19	YES	TOP
9	2	C14, C15	8pF	Chip Monolithic Ceramic Capacitor	GCM1555C1H8R0WA16	YES	TOP
10	1	C24	10uF	Multi-layer Ceramic Capacitor	CL05A106MP5NUNC	YES	TOP
11	3	C25, C42, C43	330nF	Multilayer Ceramic Chip Capacitor	CGA2B1X7S1C334K050BC	YES	TOP
12	2	C26, C27	2.2uF	Chip Monolithic Ceramic Capacitor	GRM188R61E225KA12	YES	TOP
13	1	C28	47nF	Multilayer Ceramic Chip Capacitor	C1608X8R1H473K080AA	YES	TOP
14	1	C39	22uF	Temperature Stable MLCC Ceramic Capacitor	C1210C226K4PACTU	YES	TOP
15	2	C40, C44	10pF	Chip Monolithic Ceramic Capacitor	GCM1555C1H100FA16	YES	TOP



## AURIX™ lite-Kit V1.1

### Hardware Description

16	1	CAN	HTSW-102-07-L-S	Through hole .025" SQ Post Header, 2.54mm pitch, 2 pin, vertical, single row	HTSW-102-07-L-S	YES	TOP
17	1	D4	BAT54-02LRH	Silicon Schottky Diode	BAT54-02LRH	YES	TOP
18	1	DAP	-	SMT Micro Header, 1.27mm pitch, 10 pin, vertical, double row, keying shroud,DAP	GPEC214-0502B009C1BC	YES	TOP
19	1	G1	IFX27001TFV33	Linear Voltage Regulator, 4.7 to 40 V Supply, 3.3 V Output	IFX27001TFV33	YES	TOP
20	1	IC1	FT2232HL	Dual High Speed USB to Multipurpose UART/FIFO IC	FT2232HL	YES	TOP
21	2	L1, L2		Chip Bead For Signal Line	MMZ1608R300ATA00	YES	TOP
22	5	LED1, LED2, D1, D2, D5	Green	Surface Mount LED, Green, 570nm	LG L29K-G2J1-24	YES	TOP
23	1	LED3 ESR0	Red		LSQ976-Z	YES	TOP
24	2	MIKROBUS		mikroBUS Host Socket	2212S-08SG-85	NO	TOP
25	1	Q2	SPD04P10PL G	SIPMOS Power-Transistor -100V	SPD04P10PL G	YES	TOP
26	2	R1, R2	100R	General Purpose Chip Resistor	RC0603FR-07100RL	YES	TOP
27	6	R3, R8, R9, R11, R12, R14	10k	Standard Thick Film Chip Resistor	CRCW040210K0FK	YES	TOP
28	2	R4, R5	22R	Standard Thick Film Chip Resistor	CRCW040222R0FK	YES	TOP
29	3	R6, R30, R36	1k	1k/50V/5%	RC0402JR-131KL	YES	TOP
30	1	R7	12k	Standard Thick Film Chip Resistor	CRCW040212K0FK	YES	TOP
31	3	R10, R18, R19	4.7k	General Purpose Chip Resistor	RC0402FR-074K7L	YES	TOP
32	8	R13, R22, R27, R33, R34, R35, R37, R38,	0R	Standard Thick Film Chip Resistor	CRCW12100000Z0	YES	TOP
33	1	R15	120R	Standard Thick Film Chip Resistor	CRCW0402120RFK	YES	TOP
34	3	R17, R20, R26	2.2k	Standard Thick Film Chip Resistor	CRCW040222K20FK	YES	TOP
35	3	R21, R23, R24	680R	Standard Thick Film Chip Resistor	CRCW0603680RFK	YES	TOP
36	1	R25	1.2R	Standard Thick Film Chip Resistor	CRCW06031R20FK	YES	TOP
37	2	R28, R29	6.8R	Standard Thick Film Chip Resistor	CRCW06036R80FK	YES	TOP
38	1	R32	23AR10KLFT R	Surface Mount Single Turn Trimmer, Model 23A - J Hook	23AR10KLFT R	YES	TOP
39	2	S2G1, S2G2		1x8, 2.54 pitch, female Socket	2212S-08SG-85	NO	TOP
45	2	S2G1, S2G2		1x9, 2.54 pitch, female Socket	2212S-09SG-85	NO	TOP
41	1	R106	1MEG	Standard Thick Film Chip Resistor	CRCW04021M00FK	YES	TOP
42	1	U1	SN74AHC244PWR	Octal Buffer/Driver with 3-State Outputs	SN74AHC244PWR	YES	TOP



## AURIX™ lite-Kit V1.1

### Hardware Description

43	1	U2	SN74LVC1G125DBVR	Single Bus Buffer Gate With 3-State Output	SN74LVC1G125DBVR	YES	TOP
44	2	U3, U4	SN74LVC1T45DBVR	Single-Bit Dual-Supply Bus Transceiver with Configurable Voltage Translation and 3-State Outputs (Operating Temp -40Å°C to 85Å°C)	SN74LVC1T45DBVR	YES	TOP
45	1	U5	93LC46B-I/SN	1K Microwire Compatible Serial EEPROM	93LC46B-I/SN	YES	TOP
46	1	U6	IFX_SAK-TC275TU-64F200W	32-Bit Single-Chip Microcontroller with Hardware Security Mode	SAK-TC275TP-64F200W DB	YES	TOP
47	1	U7	TLE9251VSJ	High Speed CAN FD Transceiver	TLE9251VSJ	YES	TOP
48	2	X1, X2	-	2.54mm PC/104 Connector, Stackthrough, MALE	68691-440HLF	NO	Bottom
49	1	X4	-	Micro-USB 2.0 Standard, Type AB, Bottom Mount, Shell SMT	ZX62-AB-5PA(31)	YES	TOP
50	1	X300	-	Through hole .025" SQ Post Header, 2.54mm pitch, 6 pin, vertical, double row, female	TSW-103-07-L-D	NO	TOP
51	1	X301	-	Through hole .025" SQ Post Header, 2.54mm pitch, 6 pin, vertical, single row, female	2212S-06SG-85	NO	TOP
52	1	X302	-	Through hole .025" SQ Post Header, 2.54mm pitch, 8 pin, vertical, single row, female	2212S-08SG-85	NO	TOP
53	1	X303	-	Through hole .025" SQ Post Header, 2.54mm pitch, 10 pin, vertical, single row, female	2212S-10SG-85	NO	TOP
54	1	X304	-	Through hole .025" SQ Post Header, 2.54mm pitch, 8 pin, vertical, single row, female	2212S-08SG-85	NO	TOP
55	1	Y1	12MHz	SMD Crystal Unit for Automotive Application, 12.000MHz	NX3225SA-12.000M-STD-CRS-2	YES	TOP
56	1	Y2	20MHz	SMD Crystal Unit for Automotive Application, 20.000MHz, 8pF	NX8045GB-20.000M-STD-CSJ-1	YES	TOP
57	1	R31	1k	1k/50V/5%	RC0402JR-131KL	NO	TOP
58	2	R39_opt, R40_opt,	0R	Standard Thick Film Chip Resistor	CRCW1210000Z0	NO	TOP



[www.infineon.com](http://www.infineon.com)