

GCT USB4070 is designed and manufactured to be compatible with USB Type C specification latest release. Compliance testing for products conforming to the USB type-C cable and connector specification are currently under development by the USB-IF.

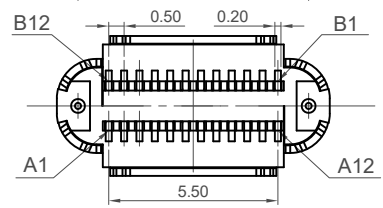
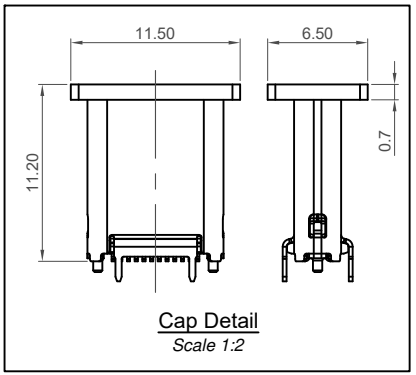
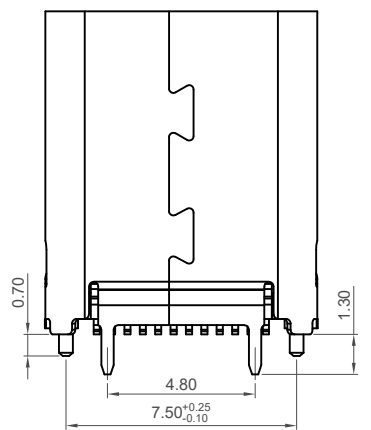
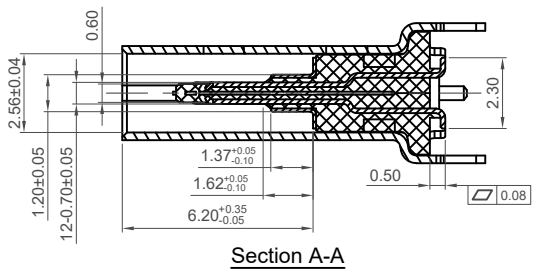
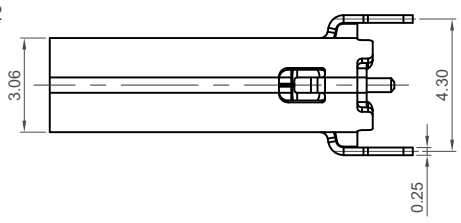
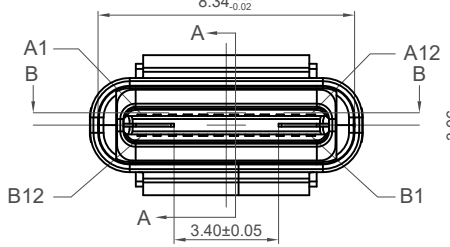
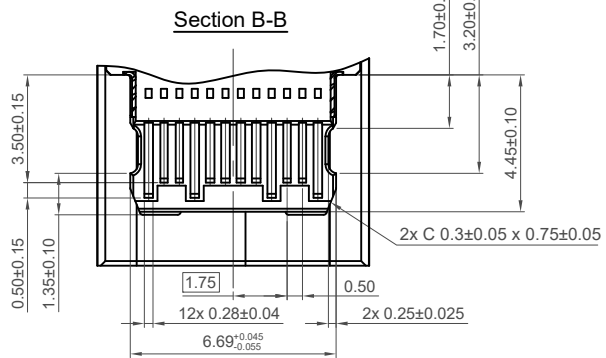

Pin	Signal	Mating Sequence	Pin	Signal	Mating Sequence
A1	GND	First	B12	GND	First
A2	SSTXp1	Second	B11	SSRXp1	Second
A3	SSTXn1	Second	B10	SSRXn1	Second
A4	Vbus	First	B9	Vbus	First
A5	CC1	Second	B8	SBU2	Second
A6	Dp1	Second	B7	Dn2	Second
A7	Dn1	Second	B6	Dp2	Second
A8	SBU1	Second	B5	CC2	Second
A9	Vbus	First	B4	Vbus	First
A10	SSRXn2	Second	B3	SSTXn2	Second
A11	SSRXp2	Second	B2	SSTXp2	Second
A12	GND	First	B1	GND	First
SHELL		GND	SHELL		GND

Specifications

Material

Insulator: High Temp. Plastic UL 94V-0, Black
 Contact: High Grade Copper Alloy (T=0.15mm)
 Shell: Stainless steel (T=0.25mm)
 Inner Ground Cover Shell: Stainless Steel (T=0.10mm)
 Mid Plate: Stainless Steel (T=0.10mm)

Plating

Contact: 30µ" Gold over 50µ" min. Nickel
 Solder Tails: 80µ" min. Matte Tin over 50µ" min. Nickel
 Shell: 50µ" min. Nickel
 Cover Shell: 80µ" min. Nickel
 Inner Ground Cover Shell: 50µ" min. Nickel

Electrical

Current Rating: 5.00A collectively for Vbus pins
 6.25A collectively for GND pins
 1.25A for A5/B5 pin
 0.25A per pin for all other pins
 Voltage Rating: 48V DC
 Power Rating: 240W
 Contact Resistance: 40mΩ max initial.
 50mΩ max after test
 Dielectric Withstanding Voltage: 100V AC
 Insulation Resistance 100MΩ min

Mechanical & Environmental

Operating Temperature: -40°C to +85°C
 Mating Force: 5 to 20 N.
 Unmated Force: 6 to 20 N after test
 Durability: 10,000 cycles

Ordering Grid

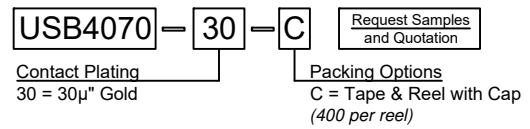

Part Number USB4070		Product Description USB 3.2 Gen2 Type C Receptacle Vertical, SMT with Shell Stakes & Locating Pegs		 www.gct.co
Drawing Date 5th May 2016				
By CC	USB4070 C PCN	Tolerances (Except as Noted) Length X. ± 0.50 X.X ± 0.30 X.XX ± 0.20 X.XXX ± 0.10	Units: Metric (mm)	 This drawing is confidential and copyright of Global Connector Technology, Ltd (GCT). This drawing must not be copied or disclosed without written consent. E & OE
Detail		± 2°		
Revision	C6			
Date	15/06/23			
Not to Scale	Drawn By AJO	Sheet No. 1/3		

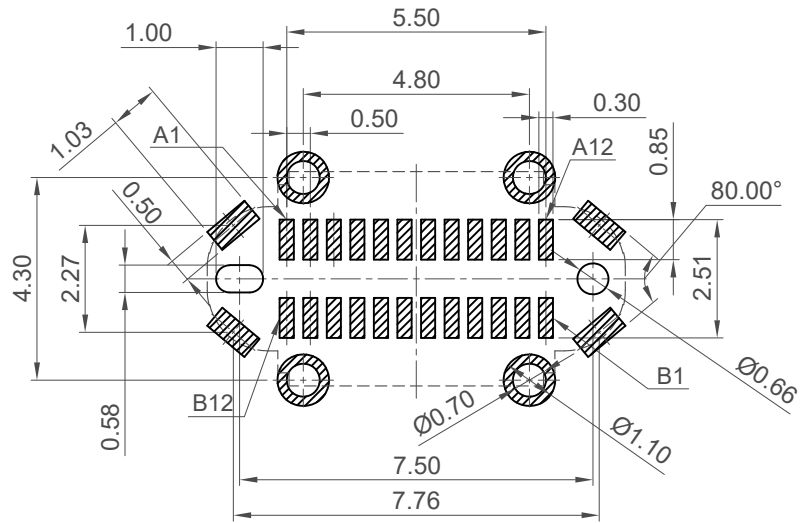

Recommended PCB Layout

as viewed from component side

Recommended PCB Thickness: 1.20mm Tolerance: $\pm 0.05\text{mm}$

Solder Area Component Outline

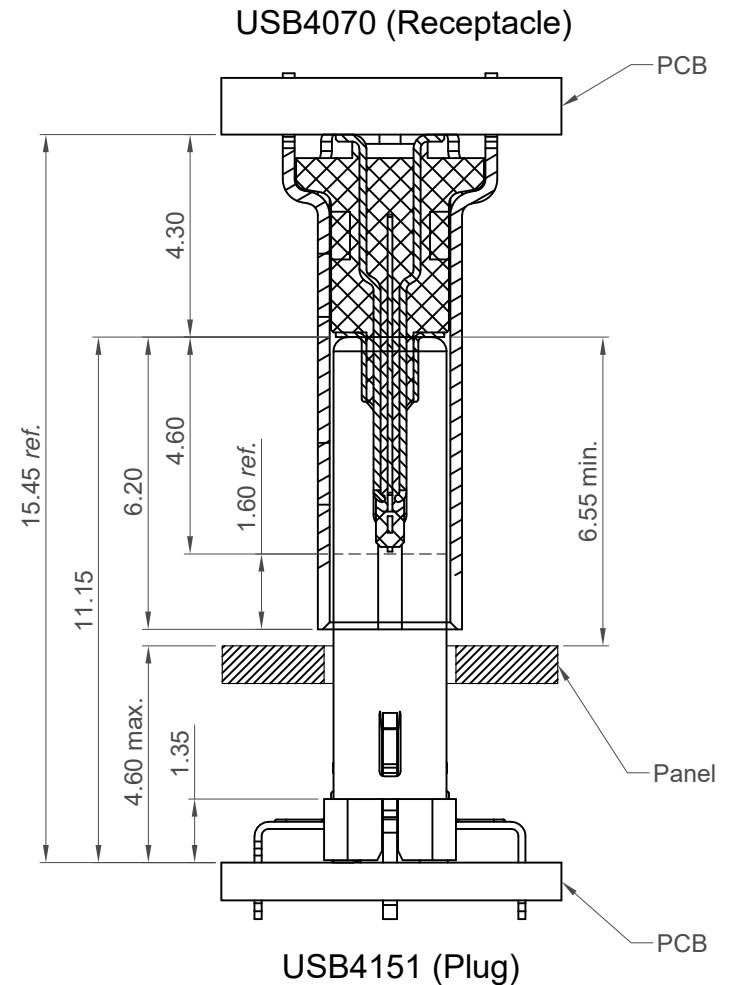
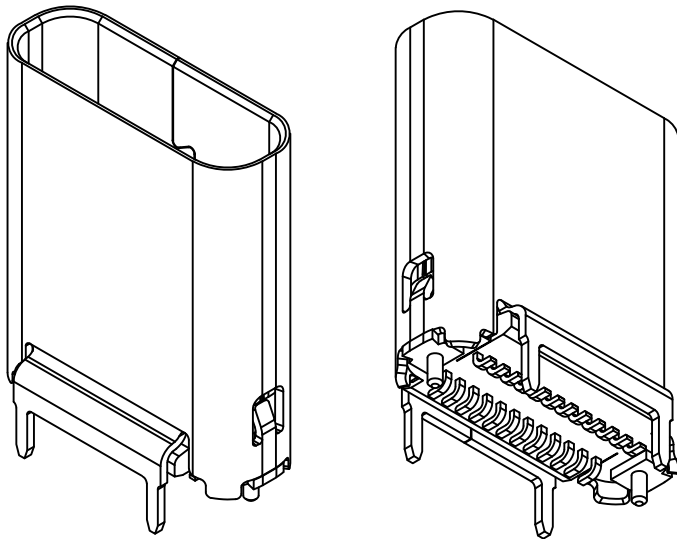

USB4151 (Plug)

Plug and Receptacle Mating View

Part Number		Product Description			This drawing is confidential and copyright of Global Connector Technology, Ltd (GCT). This drawing must not be copied or disclosed without written consent. E & OE
USB4070		USB 3.2 Gen2 Type C Receptacle			
Drawing Date		Vertical, SMT with Shell Stakes & Locating Pegs			
5th May 2016					
By	CC	Tolerances (Except as Noted)	Units:		
Detail	USB4070 C PCN	Length X. ± 0.50 XX ± 0.30 XXX ± 0.20 XXX ± 0.10	Metric (mm)		
Revision	C6	Angle $\pm 2^\circ$			
Date	15/06/23				



38.4
32.4

LABEL

Ø380

400 min.
Peeling Angle
165° ~ 180°

About 160mm long
Unloaded Section

Product Loaded Section

About 160mm long
Unloaded Section

User Direction of Unreeling

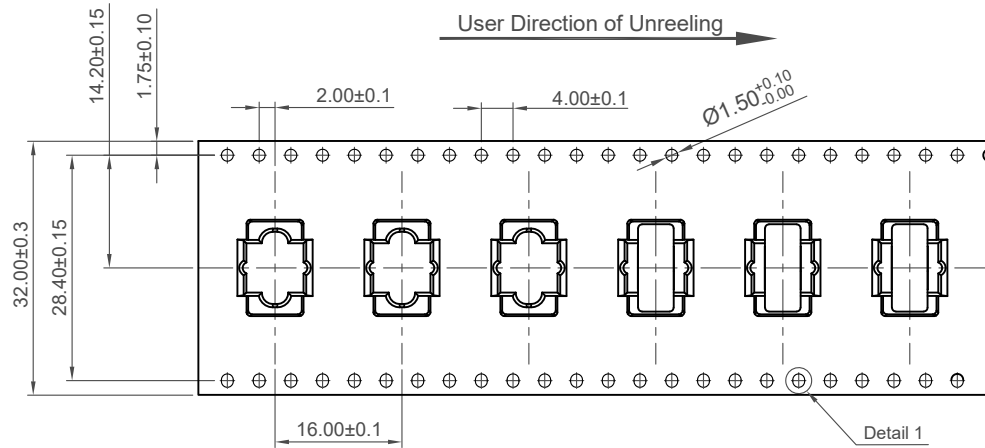

13.50±0.1

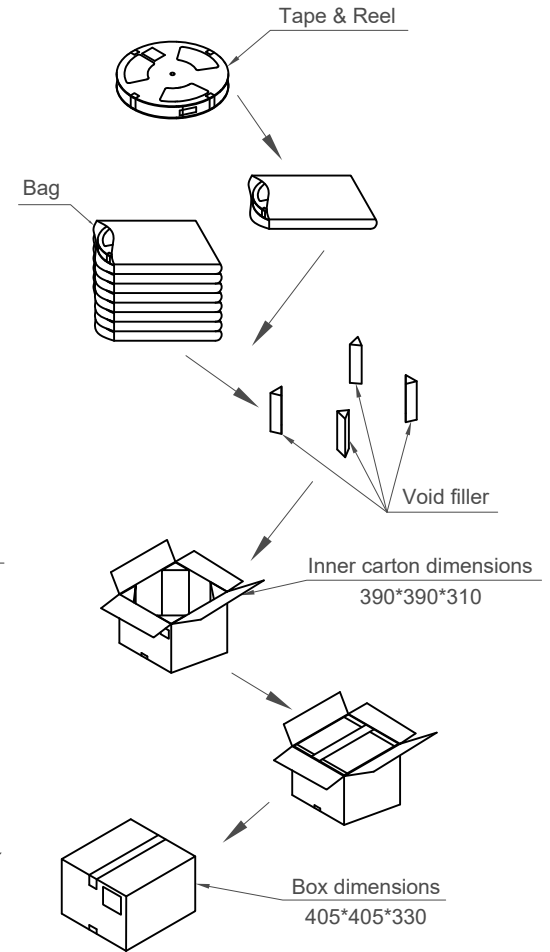
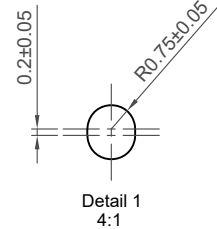

Inner carton dimensions
390*390*310

Box dimensions
405*405*330

Note

- Material
Box: Fibreboard, corrugated, double wall.
Tape: Polystyrene, heat-resistant temperature: 120°C, Black colour.
Reel: Polystyrene, heat-resistant temperature: 70°C, Blue colour.
Bag: Polyethylene, heat-resistant temperature: 100°C.
- Peeling strength: 0.1 ~ 1.3 N (10 ~ 130 grams)
- Peeling speed: 300 mm/min.
- Each bag includes desiccant.

Pcs / Reel	Reels / Carton	Total Quantity
400	8	3,200 pcs

Part Number USB4070		Product Description USB 3.2 Gen2 Type C Receptacle Vertical, SMT with Shell Stakes & Locating Pegs	
Drawing Date 5th May 2016			
By CC	Tolerances (Except as Noted) Length	Units: Metric (mm)	
Detail USB4070 C PCN	Angle		
Revision C6			
Date 15/06/23			

This drawing is confidential and copyright of Global Connector Technology, Ltd (GCT). This drawing must not be copied or disclosed without written consent. E & OE

GCT
www.gct.co

Not to Scale
Drawn By
AJO
Sheet No.
3/3

H
G
F
E
D
C
B
A

1 2 3 4 5 6 7 8