

PD42-x-1370 Hardware Manual

Hardware Version V1.10 | Document Revision V1.11 • 2019-APR-03

The PANdrive™ PD42-1-1370, PD42-2-1370, PD42-3-1370 and PD42-4-1370 are small and compact full mechatronic solutions including NEMA17 / 42mm flange size stepper motors. The PANdrives™ are controlled via RS485 bus interface using TMCL protocol. They feature an integrated magnetic encoder for position feedback, SpreadCycle™ chopper for high speed stepper motor commutation, a fully integrated hardware motion controller with s-shaped motion ramps, as well as StallGuard2™ and CoolStep™.



Features

- Stepper Motor NEMA17 with controller / driver
- 0.22 - 0.7Nm holding torque
- Supply Voltage +9... 28V DC supply voltage
- Up to 2A RMS motor current
- RS485 bus interface
- integrated s-shaped ramp motion controller in hardware
- magnetic encoder IC
- SpreadCycle™ smart mixed decay
- StallGuard2™ load detection
- CoolStep™ automatic current scaling
- Life Science
- Biotechnology
- Liquid Handling

Applications

- Laboratory Automation
- Manufacturing
- Semiconductor Handling
- Robotics
- Factory Automation
- Test & Measurement

Simplified Block Diagram

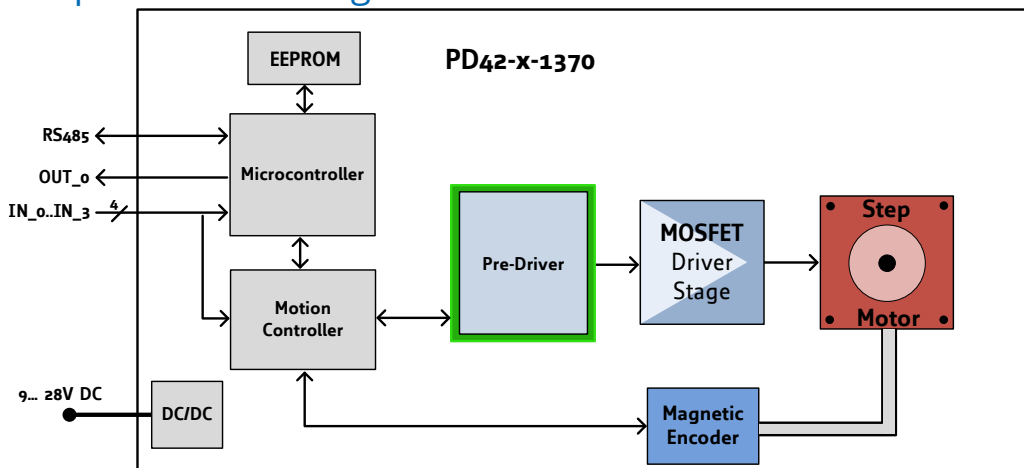

Contents

1 Features	3
2 Order Codes	4
3 Mechanical and Electrical Interfacing	5
3.1 Dimensions of PD42-x-1370	5
3.2 Stepper motor	6
3.3 Integrated Encoder	7
4 Connectors	9
4.1 Power Supply, RS485 and I/O Connector	10
4.2 Motor Connector	11
5 On-Board LEDs	12
6 I/Os	13
6.1 Digital inputs HOME, STOP_L, STOP_R and /ENABLE	13
6.2 Digital output (open-drain)	13
7 Communication	14
7.1 RS485	14
8 Motor driver current	16
9 Torque curves	18
9.1 PD42-1-1370 Torque Curve	18
9.2 PD42-2-1370 Torque Curve	18
9.3 PD42-3-1370 Torque Curve	19
9.4 PD42-4-1370 Torque Curve	19
10 Functional Description	20
11 Operational Ratings and Characteristics	21
12 Abbreviations used in this Manual	22
13 Figures Index	23
14 Tables Index	24
15 Supplemental Directives	25
15.1 Producer Information	25
15.2 Copyright	25
15.3 Trademark Designations and Symbols	25
15.4 Target User	25
15.5 Disclaimer: Life Support Systems	25
15.6 Disclaimer: Intended Use	25
15.7 Collateral Documents & Tools	26
16 Revision History	27
16.1 Hardware Revision	27
16.2 Document Revision	27



1 Features

The PANdrive™ PD42-1-1370, PD42-2-1370, PD42-3-1370 and PD42-4-1370 are small and compact full mechatronic solutions including NEMA17 / 42mm flange size stepper motors, the TMCM-1370 controller / driver electronics and magnetic encoder for position feedback and optional closed-loop operation. The four PANdrives include stepper motor with different lengths and different holding torques (PD42-1-1370: 0.22Nm, PD42-2-1370: 0.36Nm, PD42-3-1370: 0.44Nm and PD42-4-1370: 0.7Nm) but, same electronics and encoder setup. The PANdrives support both, stand-alone operation e.g. using the on-board I/Os together with the build-in TMCL scripting feature and remote operation using one of the available communication interfaces and even a mixture of both.

Motion Controller

- Fully integrated hardware motion controller with s-shaped motion ramp support
- Motion profile calculation in real-time
- On the fly alteration of motor parameters (e.g. position, velocity, acceleration)
- Automatic position regulation in hardware (optional, with integrated encoder)

Driver

- Motor current: up to 2A RMS (2.8A peak, programmable in software)
- Supply voltage: +24V DC (+9... +28V DC)
- 256 microsteps per fullstep
- SpreadCycle™ highly dynamic current control chopper

Encoder

- integrated magnetic / hall sensor based absolute position encoder

Interfaces

- RS485 interface (up-to 1Mbit/s)
- HOME, Left and Right STOP switch inputs
- Driver enable input
- Digital output (open-drain)

Software

- TMCL™ remote (direct mode) and standalone operation (memory for up to 1024 TMCL™ commands), fully supported by TMCL-IDE (PC based integrated development environment). Please see PD42-x-1370 TMCL firmware manual for more details



2 Order Codes

The combination of motor and motor mounted controller/driver electronic is currently available with four stepper motors (different length and holding torque):

The length of the PANdrives is specified without the length of the axis. For the overall length of the product please add 24mm

Order Code	Description	Size (LxWxH)
PD42-1-1370	PANdrive™with NEMA17 stepper motor, 0.22Nm max., 2A RMS, +24V, S-ramps, magnetic encoder, RS485, TMCL firmware	42mm x 42mm x 47mm
PD42-2-1370	PANdrive™with NEMA17 stepper motor, 0.36Nm max., 2A RMS, +24V, S-ramps, magnetic encoder, RS485, TMCL firmware	42mm x 42mm x 51mm
PD42-3-1370	PANdrive™with NEMA17 stepper motor, 0.44Nm max., 2A RMS, +24V, S-ramps, magnetic encoder, RS485, TMCL firmware	42mm x 42mm x 60mm
PD42-4-1370	PANdrive™with NEMA17 stepper motor, 0.7Nm max., 2A RMS, +24V, S-ramps, magnetic encoder, RS485, TMCL firmware	42mm x 42mm x 73mm

Table 1: Order Code

A cable loom set is available for this module:

Order Code	Description
PD42-1370-CABLE	Cable loom for PD42-1370: <ul style="list-style-type: none"> • 1x cable loom for power supply, RS485 and I/O connector (cable length 200mm, 10pin JST PH connector at one end, open wires at the other end)

Table 2: PD42-x-1370 Cable Loom



3 Mechanical and Electrical Interfacing

All PD42-x-1370 consist of one out of four available NEMA17 / 42mm stepper motors with 2A RMS rated coil current with the same controller / driver electronics mounted on its backside and integrated magnetic encoder. The PD42-1-1370 uses the QSH4218-34-20-022 stepper motor with 0.22Nm holding torque, the PD42-2-1370 uses the QSH4218-38-20-036 stepper motor with 0.36Nm holding torque, the PD42-3-1370 uses the QSH4218-47-20-044 stepper motor with 0.44Nm holding torque and the PD42-4-1370 uses the QSH4218-60-20-070 stepper motor with 0.7Nm holding torque.

NOTICE **Note:** In order to make proper use of the integrated magnetic encoder (the sensor IC is placed on the bottom of the pcb) the controller /driver electronics should not be removed/moved relative to the motor. In case the integrated encoder feature is not used, the electronics may be moved or even removed from the motor and placed somewhere else according to application requirements.

3.1 Dimensions of PD42-x-1370

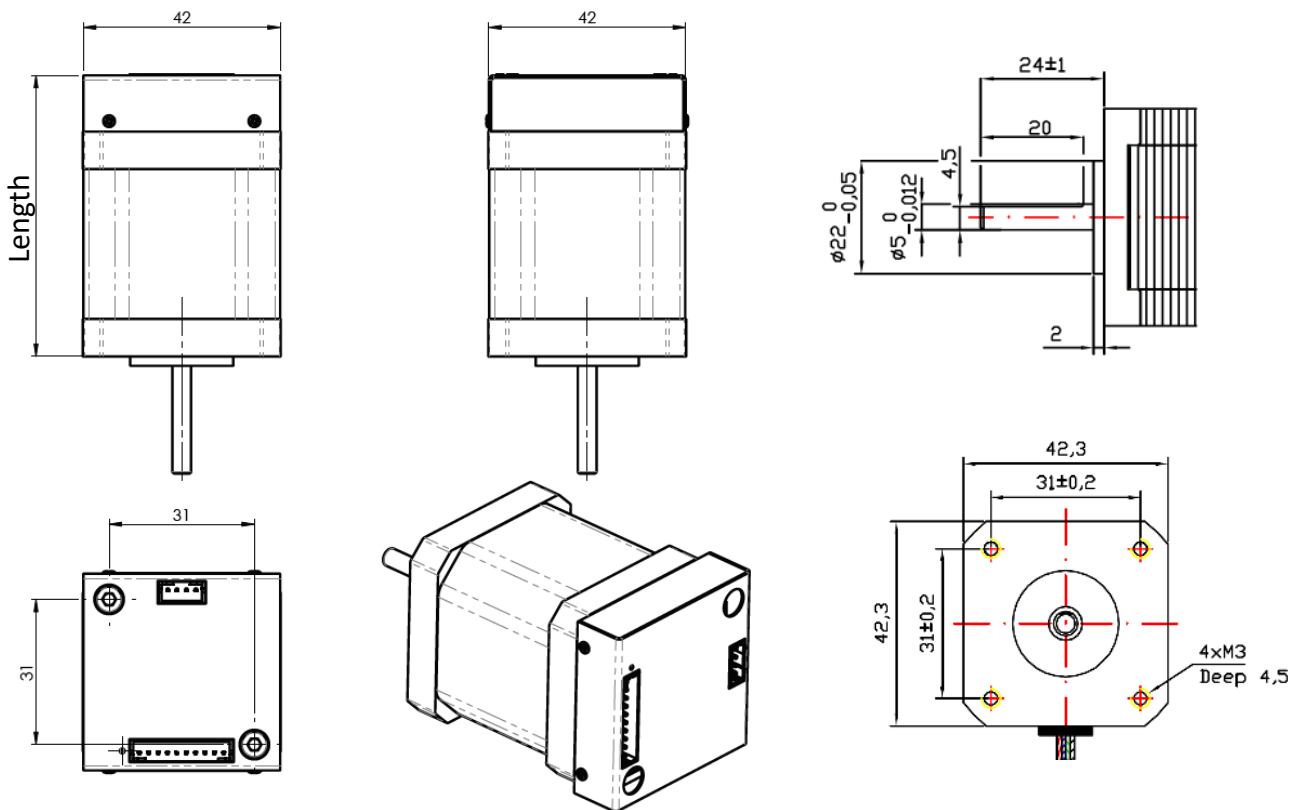

Figure 1: PD42-x-1370 with different NEMA17 / 42mm stepper motors (all dimensions in mm)

PANdrive	Overall length of unit
PD42-1-1370	46.5 ±1 mm
PD42-2-1370	51 ±1 mm



PANdrive	Overall length of unit
PD42-3-1370	60 ±1 mm
PD42-3-1370	73 ±1 mm

Table 3: Overall length of PANdrive units (body without motor axis)

3.2 Stepper motor

Main characteristics of the four different motors available as part of the PD42-x-1370 PANdrive™:

Specifications	Unit	PD42-1-1370	PD42-2-1370	PD42-3-1370	PD42-4-1370
Step angle	°	1.8	1.8	1.8	1.8
Step angle accuracy	%	+/-5	+/-5	+/-5	+/-5
Ambient temperature	°C	-20...+50	-20...+50	-20...+50	-20...+50
Max. motor temperature	°C	80	80	80	80
Shaft radial play (450g load)	mm	0.02	0.02	0.02	0.02
Shaft axial play (450g load)	mm	0.08	0.08	0.08	0.08
Max radial force (20mm from front flange)	N	28	28	28	28
Max axial force	N	10	10	10	10
Rated voltage	V	2.0	2.4	2.4	4.4
Rated phase current	A	2.0	2.0	2.0	2.0
Phase resistance at 20°C	Ω	1.0	1.2	1.4	2.3
Phase inductance (typ.)	mH	1.6	2.2	2.1	6.0
Holding torque	Nm	0.22	0.36	0.44	0.70
Insulation class		B	B	B	B
Rotor inertia	g cm ²	35	57	68	102
Weight	kg	0.22	0.24	0.35	0.5

Table 4: NEMA17 / 42mm stepper motor technical data



3.3 Integrated Encoder

The PD42-x-1370 line of PANdrives™ offers an integrated encoder based on hall sensor technology with a resolution of 12bit per rotation. When comparing with our sensOstep™ solutions which are also hall sensor based this encoder offers superior performance with comparatively high update rates and low latency.

In combination with our latest generation of hardware motion controller ICs this architecture offers cost optimized closed-loop support. In order to enable closed-loop operation the following sequence of TMCL commands may be used:

```

1   SAP 6, 0, 255           // set run current to 2A (RMS)
3
4   // closed loop field weakening settings
5   SAP 108, 0, 300000    // gamma Vmin
6   SAP 109, 0, 600000    // gamma Vmax
7
8   SAP 115, 0, 2000      //set closed loop correction velocity P
9   SAP 116, 0, 20        //set closed loop correction velocity I
10
11  SAP 117, 0, 2000      //set closed loop correction velocity I clipping
12  SAP 118, 0, 0         //set closed loop correction velocity DV clock
13  SAP 119, 0, 200000    //set closed loop correction velocity DV clipping
14
15  SAP 129, 0, 1         // Turn on closed loop
16
17  WaitInit:
18  GAP 133, 0           // Wait until closed loop init finished
19  JC ZE, WaitInit
20
21  // acceleration, velocity settings (example)
22  SAP 4, 0, 600000
23  SAP 5, 0, 800000     // set acceleration
24  SAP 17, 0, 800000    // set deceleration
25  Stop

```

Please note that this code snippet should be regarded as starting point for application specific optimizations of regulation parameters.

Field weakening is mandatory for higher speed operation in closed loop mode. As torque curve decreases earlier when ramping up speed for the longer motors with higher holding torque field weakening may be applied earlier, already. Therefore, for the PANdrive™ with the longest motor (PD42-4-1370) the field weakening parameters should be adjusted accordingly:

```

2   SAP 6, 0, 255           // set run current to 2A (RMS)
3
4   // closed loop field weakening settings
5   SAP 108, 0, 110000    // gamma Vmin
6   SAP 109, 0, 400000    // gamma Vmax
7
8   SAP 115, 0, 2000      //set closed loop correction velocity P
9   SAP 116, 0, 20        //set closed loop correction velocity I
10
11  SAP 117, 0, 2000      //set closed loop correction velocity I clipping
12  SAP 118, 0, 0         //set closed loop correction velocity DV clock
13  SAP 119, 0, 200000    //set closed loop correction velocity DV clipping
14
15  SAP 129, 0, 1         // Turn on closed loop
16
17  WaitInit:

```



```
18   GAP 133, 0           // Wait until closed loop init finished
    JC ZE, WaitInit

20   // acceleration, velocity settings (example)
    SAP 4, 0, 600000
22   SAP 5, 0, 800000    // set acceleration
    SAP 17, 0, 800000   // set deceleration
24   Stop
```



4 Connectors

The PD42-x-1370 offers two connectors - one 10 pin connector for power supply, communication (RS485) and IOs and one 4 pin connector for connecting the stepper motor.

NOTICE

Start with power supply OFF and do not connect or disconnect motor during operation! Motor cable and motor inductivity might lead to voltage spikes when the motor is (dis)connected while energized. These voltage spikes might exceed voltage limits of the driver MOSFETs and might permanently damage them. Therefore, always switch off / disconnect power supply or at least disable driver stage before connecting / disconnecting motor.

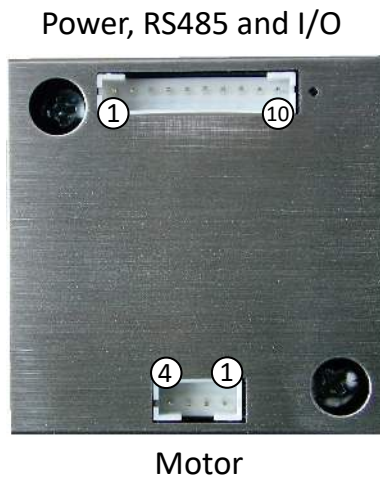

Figure 2: PD42-x-1370 connectors

Connector Types and Mating Connectors		
Connector	Connector type on-board	Mating connector type
Power, RS485 and I/O	JST B10B-PH-K-S (JST PH series, 10pins, 2mm pitch)	Connector housing: JST PHR-10 Contacts: JST SPH-002T-P0.5S Wire: 0.22mm ² , AWG 24
Motor	JST B4B-PH-K-S (JST PH series, 4pins, 2mm pitch)	Connector housing: JST PHR-4 Contacts: JST SPH-002T-P0.5S Wire: 0.22mm ² , AWG 24

Table 5: Connector Types and Mating Connectors of the PD42-x-1370



4.1 Power Supply, RS485 and I/O Connector

The PD42-x-1370 offers one 10pin JST PH connector for power supply input, communication and I/O. For communication a 2-wire RS485 bus interface is available. The four digital inputs have dedicated functions as HOME, STOP_L and STOP_R inputs and one driver enable input (active low). All four inputs offer internal pull-ups to approx. +5V. The HOME, STOP_L and STOP_R inputs may be used as general purpose inputs, also - configurable in software depending on application. In addition to the four inputs one general purpose digital output (open drain) is available. This output offers an internal pull-up resistor to +5V in order to maintain a valid logic level while the internal transistor is disabled. The output transistor (MOSFET) may sink up-to 100mA when activated and can withstand voltages up-to 30V.

Power Supply, Communication and I/O Connector Pin Assignment			
Pin	Label	Direction	Description
1	GND	Power (GND)	Common system supply and signal ground
2	V _{MAIN}	Power (input)	Main power supply input for the driver and on-board logic 9...28V
3	RS485+	Bidirectional	RS485 interface, diff. signal (non-inverting)
4	RS485-	Bidirectional	RS485 interface, diff. signal (inverting)
5	GND	Power (GND)	Common system supply and signal ground
6	OUT0	Output (OD)	Open-Drain output. Output will be pulled low when activated. <i>Voltages up-to logic supply input level are supported here. Max. continuous pull-down current: 100mA</i>
7	HOME	Input	Digital input +5V and +3V3 level compatible. Internal pull-up to approx. +5V. Can be used as dedicated HOME sensor input or as general purpose digital input (application and firmware dependent)
8	STOP_L	Input	Digital input +5V and +3V3 level compatible. Internal pull-up to approx. +5V. Can be used as dedicated STOP left sensor input or as general purpose digital input (application and firmware dependent)
9	STOP_R	Input	Digital input +5V and +3V3 level compatible. Internal pull-up to approx. +5V. Can be used as dedicated STOP right sensor input or as general purpose digital input (application and firmware dependent)
10	/ENABLE	Input	Digital input +5V and +3V3 level compatible. Internal pull-up to approx. +5V. Driver enable input (active low). Has to be pulled low / connected to GND in order to activate driver stage

Table 6: Power supply, communication and I/O connector pin assignment

NOTICE

Do not connect or disconnect motor during operation! Motor cable and motor inductivity might lead to voltage spikes when the motor is (dis)connected while energized. These voltage spikes might exceed voltage limits of the driver MOSFETs and might permanently damage them. Therefore, always switch off / disconnect power supply or at least disable driver stage before connecting / disconnecting motor.



NOTICE**Take care of polarity, wrong polarity can destroy the board!****NOTICE****Connect Enable pin to GND in order to enable motor movements!**

4.2 Motor Connector

A second 4pin JST PH series connector is available for connection of a 2-phase bipolar stepper motor. This connector is usually connected to the attached motor already.

Motor Connector Pin Assignment			
Pin	Label	Direction	Description
1	OB1	out	Pin 1 of motor coil B (red)
2	OB2	out	Pin 2 of motor coil B (blue)
3	OA1	out	Pin 1 of motor coil A (green)
4	OA2	out	Pin 2 of motor coil A (black)

Table 7: Motor Connector Pin Assignment

NOTICE

Do not connect or disconnect motor during operation! Motor cable and motor inductivity might lead to voltage spikes when the motor is (dis)connected while energized. These voltage spikes might exceed voltage limits of the driver MOSFETs and might permanently damage them. Therefore, always switch off / disconnect power supply or at least disable driver stage before connecting / disconnecting motor.



5 On-Board LEDs

The board offers one green LED in order to indicate board status. The function of the LED is dependent on the firmware version. With standard TMCL firmware the green LED should be flashing slowly during operation. When there is no valid firmware programmed into the board or during firmware update the green LED is switched on, permanently. During reset to factory default values the green LED will be flashing fast.

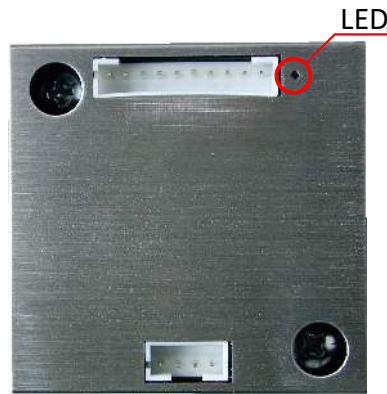

Figure 3: PD42-x-1370 LEDs

6 I/Os

The power supply, communication and I/O connector (10pin JST PH series) offers four digital inputs with integrated pull-ups and one output (open-drain).

6.1 Digital inputs HOME, STOP_L, STOP_R and /ENABLE

The PD42-x-1370 offers four digital inputs IN0...IN3 which accept signals between 0 and 28V (positive supply voltage limit) with voltages above approx. 2V recognized as logical '1' and below 0.8V as logical '0'. All four inputs offer integrated pull-ups to +5V (fixed). Depending on configuration in software these four inputs also offer dedicated functionality as HOME, STOP_L, STOP_R and /ENABLE inputs.

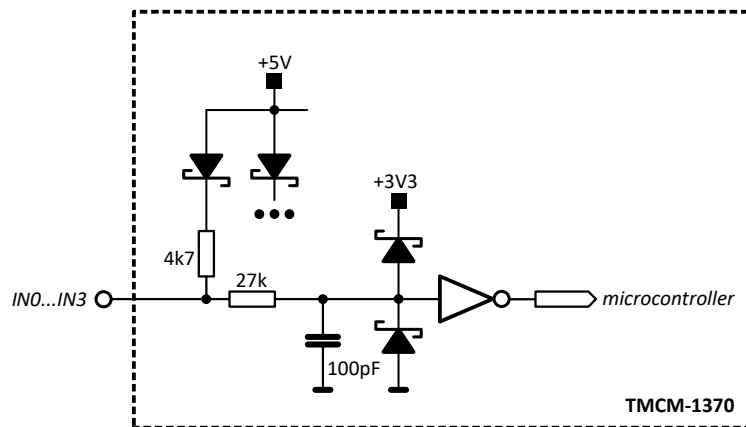

Figure 4: Digital inputs HOME, STOP_L, STOP_R and /ENABLE

6.2 Digital output (open-drain)

The PD42-x-1370 offers one digital output (open-drain). The output offers an integrated pull-up to +5V in order to ensure valid signal levels even while the output is switched off. The output can sink up-to 100mA and withstand voltages up-to 28V (positive supply voltage limit) while switched off.

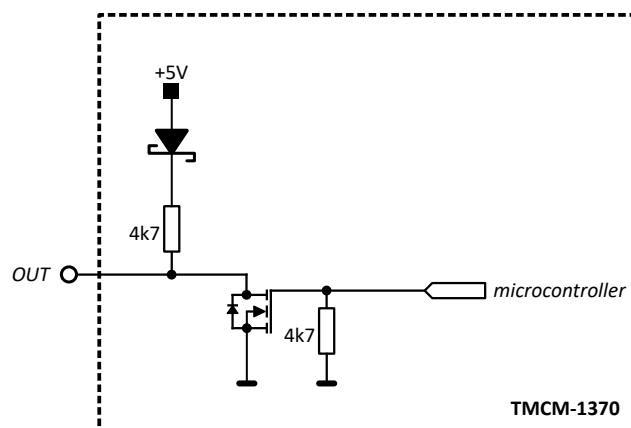

Figure 5: External encoder input



7 Communication

7.1 RS485

For remote control and communication with a host system the PD42-x-1370 provides a two wire RS485 bus interface. For proper operation the following items should be taken into account when setting up an RS485 network:

1. **BUS STRUCTURE:**

The network topology should follow a bus structure as closely as possible. That is, the connection between each node and the bus itself should be as short as possible. Basically, it should be short compared to the length of the bus.

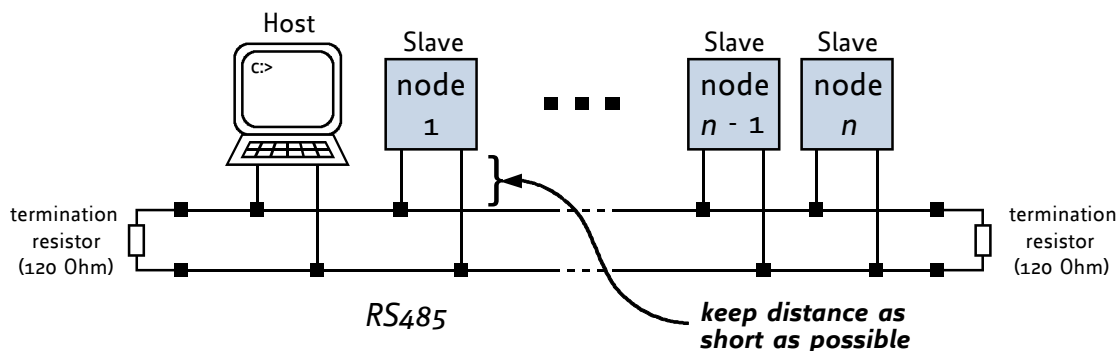

Figure 6: RS485 bus structure with termination resistors

2. **BUS TERMINATION:**

Especially for longer busses and/or multiple nodes connected to the bus and/or high communication speeds, the bus should be properly terminated at both ends. The PD42-x-1370 does not integrate any termination resistor. Therefore, 120 Ohm termination resistors at both ends of the bus have to be added externally.

3. **NUMBER OF NODES:**

The RS485 electrical interface standard (EIA-485) allows up to 32 nodes to be connected to a single bus. The bus transceiver used on the PD42-x-1370 units (SN65HVD1781D) offers a significantly reduced bus load compared to the standard and allows a maximum of 255 units to be connected to a single RS485 bus using standard TMCL firmware. *Please note: usually it cannot be expected to get reliable communication with the maximum number of nodes connected to one bus and maximum supported communication speed at the same time. Instead, a compromise has to be found between bus cable length, communication speed and number of nodes.*

4. **COMMUNICATION SPEED:**

The maximum RS485 communication speed supported by the PD42-x-1370 hardware is 1Mbit/s. Factory default is 9600 bit/s. Please see separate PD42-x-1370 TMCL firmware manual for information regarding other possible communication speeds below the upper hardware limit.

5. **NO FLOATING BUS LINES:**

Avoid floating bus lines while neither the host/master nor one of the slaves along the bus line is transmitting data (all bus nodes switched to receive mode). Floating bus lines may lead to communication errors. In order to ensure valid signals on the bus it is recommended to use a resistor network connecting both bus lines to well defined logic levels.

There are actually two options which can be recommended: Add resistor (bias) network on one side of the bus, only (120R termination resistor still at both ends):



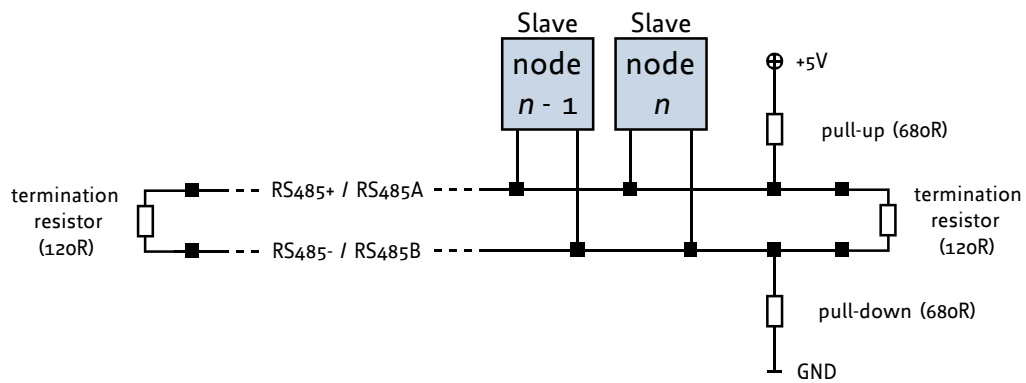

Figure 7: RS485 bus lines with resistor (bias) network on one side, only

Or add resistor network at both ends of the bus (like Profibus™ termination):

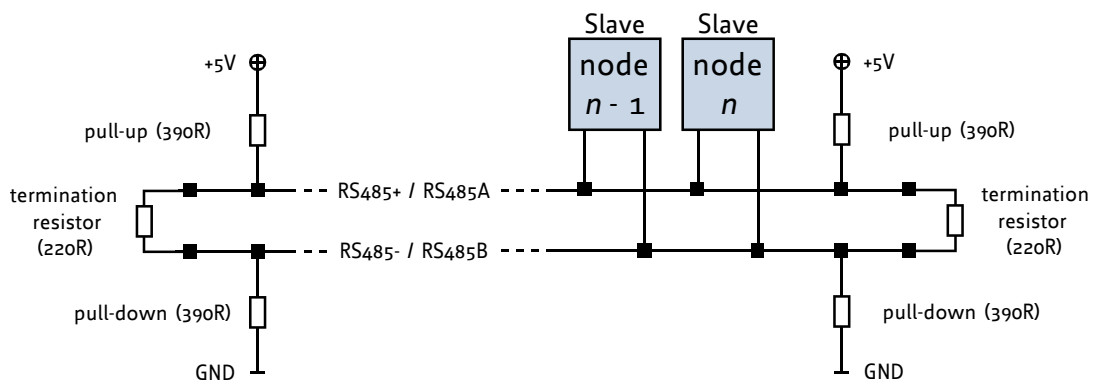

Figure 8: RS485 bus lines with Profibus™ recommended line termination



8 Motor driver current

The on-board stepper motor driver operates current controlled. The driver current may be programmed in software with 32 effective scaling steps in hardware.

Explanation of different columns in table below:

Motor current setting in software (TMCL) These are the values for TMCL axis parameter 6 (motor run current) and 7 (motor standby current). They are used to set the run / standby current using the following TMCL commands:

SAP 6, 0, <value> // set run current

SAP 7, 0, <value> // set standby current

(read-out value with GAP instead of SAP. Please see separate PD42-x-1370 firmware manual for further information)

Motor current I_{RMS} [A] Resulting motor current based on motor current setting

Motor Current Setting			
Motor current setting in software (TMCL)	Current scaling step (CS)	Motor current I_{COIL} [A] peak	Motor current I_{COIL} [A] RMS
0...7	0	0.092	0.065
8...15	1	0.184	0.130
16...23	2	0.276	0.195
24...31	3	0.368	0.260
32...39	4	0.460	0.326
40...47	5	0.552	0.391
48...55	6	0.645	0.456
56...63	7	0.737	0.521
64...71	8	0.829	0.586
72...79	9	0.921	0.651
80...87	10	1.013	0.716
88...95	11	1.105	0.781
96...103	12	1.197	0.846
104...111	13	1.289	0.912
112...119	14	1.381	0.977
120...127	15	1.473	1.042
128...135	16	1.565	1.107
136...143	17	1.657	1.172
144...151	18	1.749	1.237
152...159	19	1.842	1.302



Motor current setting in software (TMCL)	Current scaling step (CS)	Motor current I_{COIL} [A] peak	Motor current I_{COIL} [A] RMS
160...167	20	1.934	1.367
168...175	21	2.026	1.432
176...183	22	2.118	1.497
184...191	23	2.210	1.563
192...199	24	2.302	1.628
200...207	25	2.394	1.693
208...215	26	2.486	1.758
216...223	27	2.578	1.823
224...231	28	2.670	1.888
232...239	29	2.762	1.953
240...247	30	2.854	2.018
248...255	31	2.946	2.083

Table 9: Available motor current settings

In addition to the settings in the table the motor current may be switched off completely (free-wheeling) using axis parameter 204 (see PD42-x-1370 firmware manual).



9 Torque curves

9.1 PD42-1-1370 Torque Curve

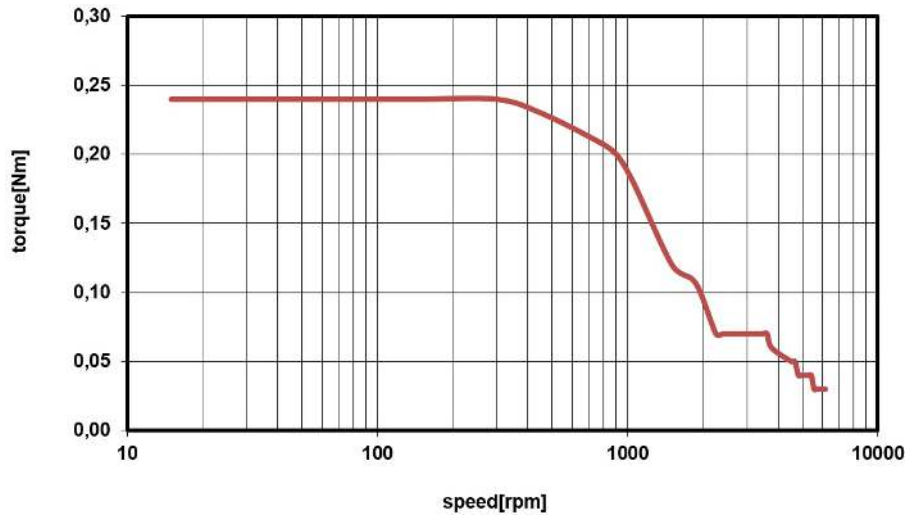

Figure 9: PD42-1-1370 torque vs. velocity 24V / 2A, 256 μ steps, open-loop

9.2 PD42-2-1370 Torque Curve

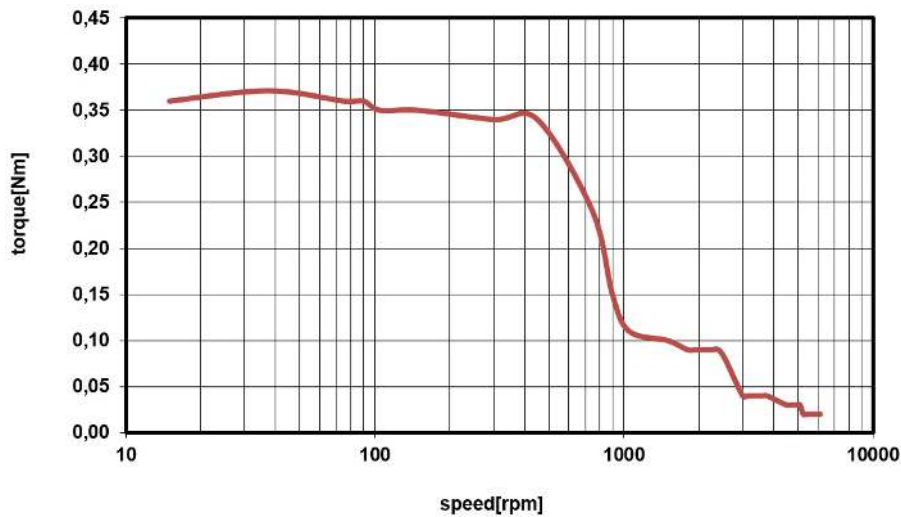

Figure 10: PD42-2-1370 torque vs. velocity 24V / 2A, 256 μ steps, open-loop



9.3 PD42-3-1370 Torque Curve

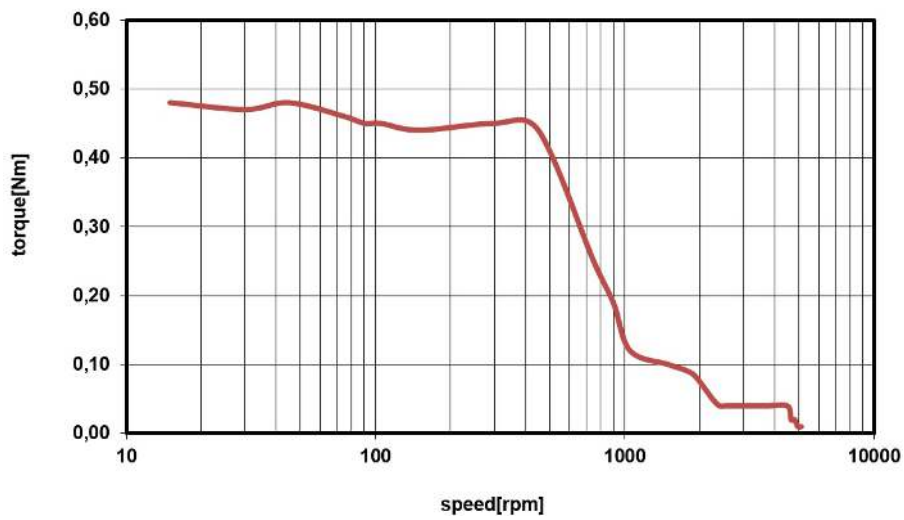

Figure 11: PD42-3-1370 torque vs. velocity 24V / 2A, 256 μ steps, open-loop

9.4 PD42-4-1370 Torque Curve

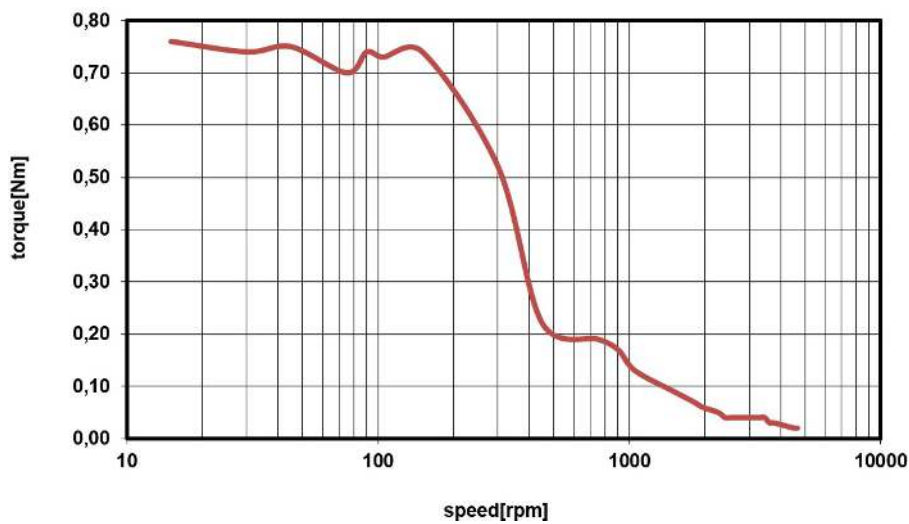

Figure 12: PD42-4-1370 torque vs. velocity 24V / 2A, 256 μ steps, open-loop



10 Functional Description

The PD42-x-1370 is a full mechatronic solution including a 42mm flange (NEMA17) bipolar stepper motor. It includes the controller / driver electronics and a choice between four different NEMA 17 / 42mm flange size bipolar hybrid stepper motors with different length and torque.

The PD42-x-1370 offers an advanced s-shaped ramp motion controller in hardware. Together with the integrated high resolution magnetic encoder position regulation is supported in hardware (configurable in software). The unit can be controlled via RS485 2-wire serial interfaces. There are four general purpose digital inputs which can be used as STOP_L / STOP_R / HOME switch inputs, also (for reference movements, as end switches etc. depending on firmware, mode and configuration) and a dedicated driver enable input. In addition, there is one general-purpose output (open-drain).

The PD42-x-1370 with TMCL™ firmware option is supported by the PC based software development environment TMCL-IDE for the Trinamic Motion Control Language (TMCL™). Using predefined TMCL™ high level commands like move to position a rapid and fast development of motion control applications is guaranteed. Please refer to the PD42-x-1370 firmware manual for more information about TMCL™ commands.

Communication traffic is kept low since all time critical operations, e.g. ramp calculation, position regulation are performed on board. Complete stand-alone or full remote control or anything in-between is possible. The firmware of the module can be updated via the serial interface. As an alternative to TMCL, a CANopen firmware is available.

The PD42-x-1370 contains the following main components:

- NEMA 17 / 42mm flange size stepper motor with 2A RMS coil windings, different length and holding torque (0.22Nm ... 0.7Nm)
- Microcontroller (ARM Cortex-M4™), responsible for overall control and communication
- Advanced s-shape ramps hardware motion controller
- Advanced stepper motor driver with StallGuard2™ and CoolStep™ with MOSFET driver stage
- High-resolution magnetic / hall sensor based encoder
- RS485 transceiver
- On-board voltage regulators (+5V and +3V3) required for supply of all on-board digital circuits

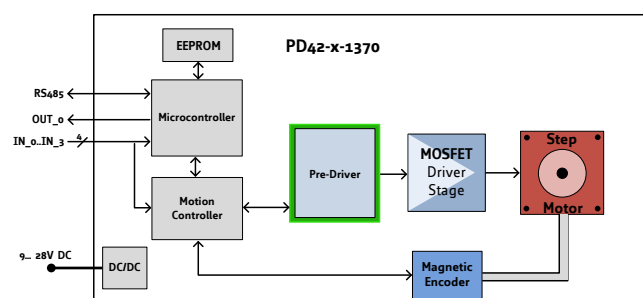

Figure 13: PD42-x-1370 block diagram



11 Operational Ratings and Characteristics

NOTICE

Never Exceed the absolute maximum ratings! Keep the power supply voltage below the upper limit of +28V! Otherwise the board electronics will seriously be damaged! Especially, when the selected operating voltage is near the upper limit a regulated power supply is highly recommended.

General Operational Ratings					
Symbol	Parameter	Min	Typ	Max	Unit
V_{Power}	Power supply voltage	9	12...24	28	V
I_{Power}	Power supply current		$\ll I_{COIL_RMS}$	$1.4 \times I_{COIL_RMS}$	A
I_{COIL_PEAK}	Motor coil current for sine wave peak (chopper regulated, adjustable via software)	0		2.8	A
I_{COIL_RMS}	Continuous motor current (RMS)	0		2	A
T_{ENV}	Environmental temperature at rated current (no forced cooling required)	-30		50	°C

Table 10: General operational ratings of the module

Operational Ratings of the I/Os					
Symbol	Parameter	Min	Typ	Max	Unit
V_{OUT0}	Voltage at open drain output OUT0 (switched off)	0		+28	V
I_{OUT0}	Output sink current of open drain output OUT0 (switched on)			100	mA
$V_{IN0/1/2/3}$	Input voltage for IN0...IN3	0	0...+24	+28	V
$V_{IN0/1/2/3}$	Low level voltage for IN0...IN3 (digital inputs)			0.8	V
$V_{IN0/1/2/3}$	High level voltage for IN0...IN3 (digital inputs)	2			V

Table 11: Operational ratings of I/Os

Operational Ratings of the RS485 Interface					
Symbol	Parameter	Min	Typ	Max	Unit
N_{RS485}	Number of nodes connected to single RS485 network			256	
f_{RS485}	Max. speed for RS485 network			1Mbit/s	

Table 12: Operational ratings of the RS485 interface



12 Abbreviations used in this Manual

Abbreviation	Description
IDE	Integrated Development Environment
LED	Light Emmitting Diode
RMS	Root Mean Square value
TMCL	TRINAMIC Motion Control Language

Table 13: Abbreviations used in this Manual



13 Figures Index

1	PD42-x-1370 with different NEMA17 / 42mm stepper motors (all dimensions in mm)	5	8	RS485 bus lines with Profibus™recommended line termination	15
2	PD42-x-1370 connectors	9	9	PD42-1-1370 torque vs. velocity 24V / 2A, 256μsteps, open-loop	18
3	PD42-x-1370 LEDs	12	10	PD42-2-1370 torque vs. velocity 24V / 2A, 256μsteps, open-loop	18
4	Digital inputs HOME, STOP_L, STOP_R and /ENABLE	13	11	PD42-3-1370 torque vs. velocity 24V / 2A, 256μsteps, open-loop	19
5	External encoder input	13	12	PD42-4-1370 torque vs. velocity 24V / 2A, 256μsteps, open-loop	19
6	RS485 bus structure with termination resistors	14	13	PD42-x-1370 block diagram	20
7	RS485 bus lines with resistor (bias) network on one side, only	15			



14 Tables Index

1	Order Code	4	7	Motor Connector Pin Assignment . . .	11
2	PD42-x-1370 Cable Loom	4	9	Available motor current settings . . .	17
3	Overall length of PANdrive units (body without motor axis)	6	10	General operational ratings of the module	21
4	NEMA17 / 42mm stepper motor technical data	6	11	Operational ratings of I/Os	21
5	Connector Types and Mating Connectors of the PD42-x-1370	9	12	Operational ratings of the RS485 interface	21
6	Power supply, communication and I/O connector pin assignment	10	13	Abbreviations used in this Manual . .	22
			14	Hardware Revision	27
			15	Document Revision	27



15 Supplemental Directives

15.1 Producer Information

15.2 Copyright

TRINAMIC owns the content of this user manual in its entirety, including but not limited to pictures, logos, trademarks, and resources. © Copyright 2021 TRINAMIC. All rights reserved. Electronically published by TRINAMIC, Germany.

Redistributions of source or derived format (for example, Portable Document Format or Hypertext Markup Language) must retain the above copyright notice, and the complete Datasheet User Manual documentation of this product including associated Application Notes; and a reference to other available product-related documentation.

15.3 Trademark Designations and Symbols

Trademark designations and symbols used in this documentation indicate that a product or feature is owned and registered as trademark and/or patent either by TRINAMIC or by other manufacturers, whose products are used or referred to in combination with TRINAMIC's products and TRINAMIC's product documentation.

This Hardware Manual is a non-commercial publication that seeks to provide concise scientific and technical user information to the target user. Thus, trademark designations and symbols are only entered in the Short Spec of this document that introduces the product at a quick glance. The trademark designation /symbol is also entered when the product or feature name occurs for the first time in the document. All trademarks and brand names used are property of their respective owners.

15.4 Target User

The documentation provided here, is for programmers and engineers only, who are equipped with the necessary skills and have been trained to work with this type of product.

The Target User knows how to responsibly make use of this product without causing harm to himself or others, and without causing damage to systems or devices, in which the user incorporates the product.

15.5 Disclaimer: Life Support Systems

TRINAMIC Motion Control GmbH & Co. KG does not authorize or warrant any of its products for use in life support systems, without the specific written consent of TRINAMIC Motion Control GmbH & Co. KG.

Life support systems are equipment intended to support or sustain life, and whose failure to perform, when properly used in accordance with instructions provided, can be reasonably expected to result in personal injury or death.

Information given in this document is believed to be accurate and reliable. However, no responsibility is assumed for the consequences of its use nor for any infringement of patents or other rights of third parties which may result from its use. Specifications are subject to change without notice.

15.6 Disclaimer: Intended Use

The data specified in this user manual is intended solely for the purpose of product description. No representations or warranties, either express or implied, of merchantability, fitness for a particular purpose



or of any other nature are made hereunder with respect to information/specification or the products to which information refers and no guarantee with respect to compliance to the intended use is given.

In particular, this also applies to the stated possible applications or areas of applications of the product. TRINAMIC products are not designed for and must not be used in connection with any applications where the failure of such products would reasonably be expected to result in significant personal injury or death (safety-Critical Applications) without TRINAMIC's specific written consent.

TRINAMIC products are not designed nor intended for use in military or aerospace applications or environments or in automotive applications unless specifically designated for such use by TRINAMIC. TRINAMIC conveys no patent, copyright, mask work right or other trade mark right to this product. TRINAMIC assumes no liability for any patent and/or other trade mark rights of a third party resulting from processing or handling of the product and/or any other use of the product.

15.7 Collateral Documents & Tools

This product documentation is related and/or associated with additional tool kits, firmware and other items, as provided on the product page at: www.trinamic.com.



16 Revision History

16.1 Hardware Revision

Version	Date	Author	Description
V0.92	2017-JUN-09	GE	Initial prototype version
V1.0	2017-OCT-13	GE	Sensor connections changed / added. Minor corrections
V1.1	2018-MAR-21	GE	Layout / mounting corrections

Table 14: Hardware Revision

16.2 Document Revision

Version	Date	Author	Description
1.00	2018-MAY-18	GE	Initial version
1.10	2018-AUG-18	GE	Notes on integrated encoder added
1.11	2019-APR-03	GE	Block diagram simplified in functional description + minor corrections

Table 15: Document Revision

